

No. 705,945.

Patented July 29, 1902.

L. F. MONCK.  
BUTTONHOLE CUTTER.

(Application filed Dec. 21, 1901.)

(No Model.)

2 Sheets—Sheet 1.

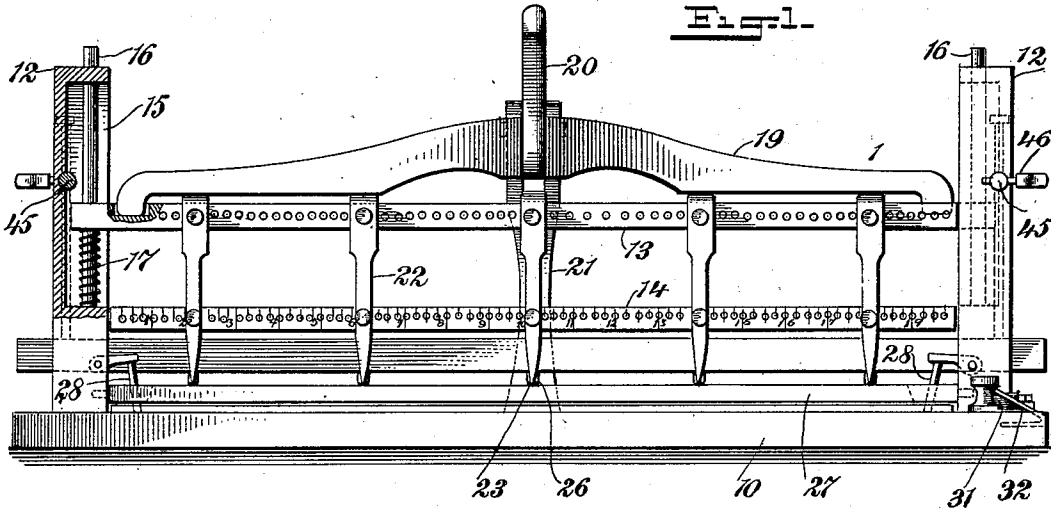
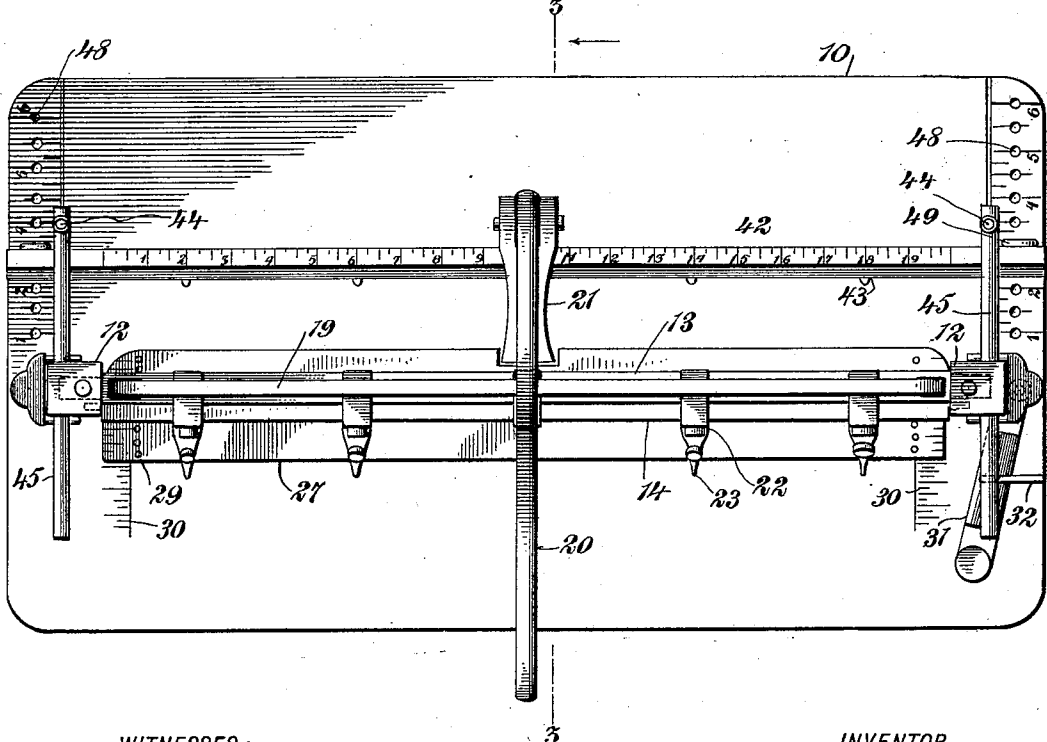

Fig. 2.



WITNESSES:

*Geo. Maylor.*  
*R. Ferguson*

INVENTOR

*Leopold F. Monck*

BY

*Munn*  
ATTORNEYS

L. F. MONCK.  
BUTTONHOLE CUTTER.  
(Application filed Dec. 21, 1901.)

(No Model.)

2 Sheets—Sheet 2.

Fig. 2.

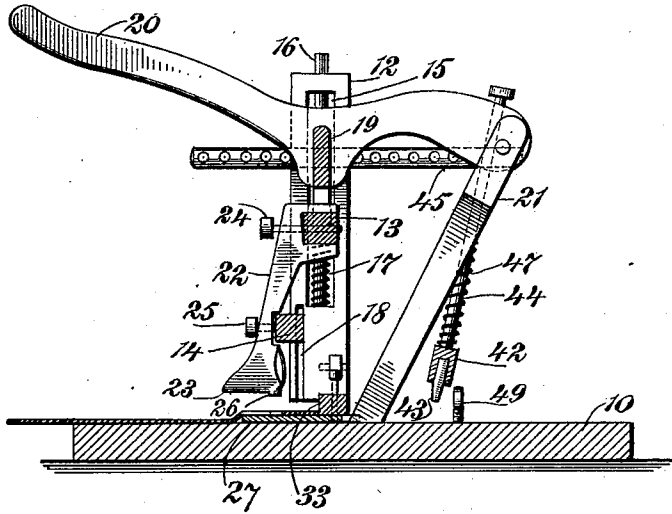

Fig. 4.

Fig. 5.

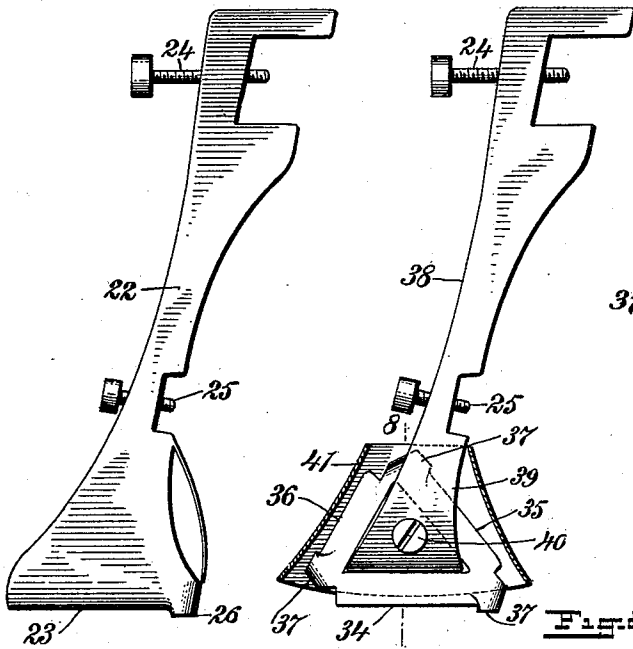

Fig. 6.

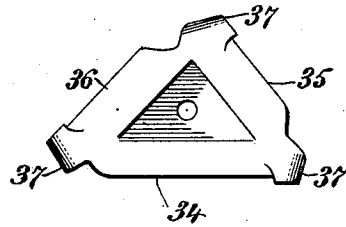
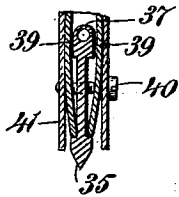

Fig. 7.



Fig. 8.



WITNESSES:

*Geo. Mayhew*  
*C. P. Ferguson*

INVENTOR  
*Leopold F. Monck*  
BY *Munck*  
ATTORNEYS

# UNITED STATES PATENT OFFICE.

LEOPOLD F. MONCK, OF NEW YORK, N. Y.

## BUTTONHOLE-CUTTER.

SPECIFICATION forming part of Letters Patent No. 705,945, dated July 29, 1902.

Application filed December 21, 1901. Serial No. 86,753. (No model.)

*To all whom it may concern:*

Be it known that I, LEOPOLD F. MONCK, a citizen of the United States, and a resident of the city of New York, borough of Manhattan, in the county and State of New York, have invented a new and Improved Buttonhole-Cutter, of which the following is a full, clear, and exact description.

This invention relates to improvements in machines for cutting buttonholes in goods and incidentally for marking on the goods the places where the buttons are to be attached; and the object is to provide a machine of this character by means of which the work may be rapidly and accurately done, resulting in an economy of labor and time, and consequently reducing the cost of production of garments or the like.

I will describe a buttonhole-cutter and button-marker embodying my invention and then point out the novel features in the appended claims.

Reference is to be had to the accompanying drawings, forming a part of this specification, in which similar characters of reference indicate corresponding parts in all the figures.

Figure 1 is a front elevation, partly in section, of a machine embodying my invention. Fig. 2 is a plan view thereof. Fig. 3 is a section on the line 3 3 of Fig. 2. Fig. 4 shows one form of cutting-knife that may be employed. Fig. 5 shows another form of cutting-knife that may be employed and illustrating it in connection with its shank. Fig. 6 is a side view of said knife removed from the shank. Fig. 7 is an edge view thereof, and Fig. 8 is a section on the line 8 8 of Fig. 5.

Referring to the drawings, 10 designates a base-plate, on which are uprights or standards 12. Movable vertically with relation to the standards are the cross-bars 13 and 14 for carrying the cutters, as will be hereinafter described. The upper cross-bar 13 extends into channels 15, formed in the standards, and engages with rods 16, arranged in said channels. The bar 13 is moved upward by means of springs 17, surrounding the rods 16 and engaging at their upper ends with said cross-bar and at their lower ends with the bottom walls of the channels. The lower cross-bar 14 is movable, but has its ends extended in channels 18, formed vertically in the stand-

ards 12 and slightly forward of the channels 15. A presser-bar 19 engages loosely at its ends with the top cross-bar 13, and at its center this presser-bar is connected to an operating-lever 20, pivoted to a standard or post 21.

Adjustably connected to the bars 13 and 14 are the shank portions 22 of cutting-blades 23. At the upper end each shank 22 has rearwardly-extended fingers for engaging against the upper and under sides of the top bar, and it is provided near its lower end with a recess to receive the lower cross-bar. These shanks may be secured in position by means of pins or screws 24 25, and for the purpose of adjustment the bars are provided each with a series of holes to receive the pins or screws, and the lower bar is provided with an inch-scale to indicate the proper distances between the cutting devices.

The cutter 23 is made in the form of a single blade having at its heel portion an eyelet-cutter 26. It is designed, however, that this blade shall cut different lengths of buttonholes. For this purpose I provide adjustably on the bed-plate a gage-plate 27, which may be moved back and forth and held as adjusted by means of pins 28, supported by the standards 12 and adapted to engage in any one of the perforations 29 formed in the ends of said gage-plate. The ends of the gage-plate are provided with a scale, and the bed-plate underneath the ends of said gage-plate is also provided with a scale 30 to indicate the proper adjustments inward or outward of said gage-plate. When it is desired to cut a buttonhole for the full length of the blade, the plate 27 is to be moved outward, so as to come underneath the whole length of the blade. When it is desired to cut a shorter buttonhole, the plate 27 is to be moved rearward, so that only a portion of the blade will cut through the goods, the part of the goods forward of the portion to be cut hanging over the front edge of the plate, as clearly indicated in Fig. 3. The goods may be held while cutting by means of a spring-plate 31, attached to the bed-plate and held against the goods by a swinging finger 32. While cutting buttonholes the edge of the goods is held against a stop-bar 33, arranged between the standards.

In the operation of the device as so far de-

scribed after the goods are placed in position a downward pressure on the lever 20 will cause the several blades to pass through the goods, and thus the required number of buttonholes will be at once cut.

In Figs. 5, 6, 7, and 8 I have shown a cutting device which is substantially triangular in outline to provide for a plurality of cutting edges 34, 35, and 36, the several cutting edges being of different lengths to provide for the cutting of buttonholes of different lengths, and at the heel portion of each cutting-section is an eyelet-cutter 37. This cutting device of course is adjustable, and therefore the shank 38, somewhat similar to the shank 22, has opposite fingers 39 at its lower end to engage against opposite sides of the cutter-plate. It will be seen that the cutter-plate at opposite sides is provided with a triangular recess, and when in position the ends of the fingers 39 will engage against the lower wall of said recess and prevent any rocking motion of the cutter-plate relatively to the shank, and the cutter-plate is to be further secured to the fingers by means of a screw or bolt 40. This cutting device is covered with a protecting-hood 41, which will prevent a person accidentally cutting his fingers on the upper exposed cutting-surfaces.

While a person is operating the buttonhole-cutting mechanism it is designed that another person may mark the places on the goods where the buttons are to be attached. Therefore arranged at the rear side of the machine is a crayon-carrying bar 42, having a series of openings in its lower side to receive marking-crayons 43, and the upper side of said bar 42 is provided with a scale to indicate the positions of the crayons. This bar 42 is attached to the lower ends of rods 44, movable in openings in rods 45, adjustable back and forth with relation to the standards 12. As here shown these rods 45 are movable in openings formed in said standards, and each rod is provided with a series of perforations to receive the holding-pin 46. The bar 42 is drawn upward by means of springs 47, surrounding said rods 44 and secured at the lower end to the bar 42 and at the upper end to the rods 45. The bed-plate 10 is provided near its ends with a series of perforations 48, which is suitably marked off with an inch-scale, and in any one of these perforations a stop or guide finger 49 may be placed. The said stops or guides are adapted to be engaged by the bar 42 on its downward movements.

In operation the piece of goods is to be placed on the bed-plate with the edge against the stop 33. Then the operator is to press downward on the bar 42, moving it along the stops or guides 49 and causing the crayons to strike upon the goods, leaving a mark. Upon releasing the pressure the springs 47 will move the bar upward, so that another piece of goods may be placed in position.

Having thus described my invention, I

claim as new and desire to secure by Letters Patent—

1. A buttonhole-cutting machine, comprising a series of cutting-blades, each blade having a plurality of cutting edges, standards, an upper cross-bar movable vertically with relation to the standards, a lower cross-bar movable vertically with relation to the standards, shank portions carrying the cutters and adjustably secured to said bars, and means for operating said bars, substantially as specified. 70

2. A buttonhole-cutting machine, comprising a base-plate, standards on said base-plate, upper and lower bars movable in said standards, cutter-carrying shanks adjustable along said bars, cutting-blades adjustable in the shanks, each blade having a plurality of cutting edges, a presser-bar engaging with one of said first-named bars, and an operating-lever connected to said presser-bar, substantially as specified. 75

3. A buttonhole-cutting machine comprising a base-plate, standards on said base-plate, cross-bars movable in said standards, cutters carried by said cross-bars, means for operating the cross-bars, and a gage-plate movable outward and inward with relation to the cutters, substantially as specified. 80

4. A buttonhole-cutting machine, comprising a base-plate, standards on said base-plate, cross-bars movable in said standards, springs for moving the cross-bars upward, a lever for moving the cross-bars downward, cutters carried by said bars and adjustable along the same, a gage-plate adjustable relatively to the cutters, and means for holding said gage-plate as adjusted, substantially as specified. 85

5. A buttonhole-cutting machine, comprising a base-plate, standards on said base-plate and provided with channels, one channel being forward of the other, a cross-bar movable in one of the channels, a cross-bar movable in the other of said channels, cutter-carrying shanks adjustably connected to said bars, cutters carried by said shanks, means for operating the bars, and a holding-clamp for the goods to be operated upon, substantially as specified. 90

6. A buttonhole-cutting machine, comprising a base-plate, standards on the base-plate, bars movable in the standards, cutter-carrying shanks attached to the bars, cutters carried by the shanks, and covering-hoods for the cutters, substantially as specified. 95

7. In a buttonhole-cutting machine, a cutter-carrying shank, and a cutter adjustable in said shank, the said cutter having a plurality of cutting edges of different lengths, substantially as specified. 100

8. In a buttonhole-cutting machine, a cutter-carrying shank, and a cutter adjustable in said shank, the said cutter having a plurality of cutting edges of different lengths, and an eyelet-cutter at one end of each cutting edge, substantially as specified. 105

9. In a buttonhole-cutting machine, a cut-

ter-carrying shank having fingers at its lower  
end, a cutter-plate arranged between said fin-  
gers, means for clamping said plate, and a  
plurality of cutting edges on said plate, the  
5 said cutting edges being of different lengths,  
substantially as specified.

10 10. In a buttonhole-cutting machine, a cut-  
ter-carrying shank having fingers at its lower  
end, a cutter consisting of a plate having a  
plurality of cutting edges of different lengths,  
the said plate being recessed at its opposite

sides to receive said fingers, and means for  
clamping the plate between the fingers, sub-  
stantially as specified.

In testimony whereof I have signed my 15  
name to this specification in the presence of  
two subscribing witnesses.

LEOPOLD F. MONCK.

Witnesses:

JOHN S. DONOHUE,  
JNO. M. RITTER.