

(19)  
(12)

(KR)  
(Y1)

(51) 。 Int. Cl. <sup>6</sup>  
A63B 53/00

(45)  
(11)  
(24)

2002 11 22  
20 - 0280906  
2002 06 25

(21) 20 - 1996 - 0030054  
(22) 1996 09 19

(65) 1997 - 0027166  
(43) 1997 07 24

(30) 08/574,449 1995 12 15 (US)

(73) 85029 2201

(72) , , , 14 14443

(74)

:

(54) 가

가 , , 가 . .  
가 , . " " " "  
가 .

1				.
2	1		(toe end)	.
3	1		(heel end)	.
4	1			.
4a	3	4 - 4	1	.
5	1			.
6	1			.
7	1			.
8	7	8 - 8		.
9	7	9 - 9		.
10	7	10 - 10		.
11	1			.

< >

10 :

12 :

14 :

16 :

18 :

20 : (neck)

22 :

24 : 가

26 :

28 :

34 : 가

36 : 가

48, 50 :

52 :

56 :

58 :

62, 64, 66, 68, 70 :

가

가

" (open)" " (close)"  
가 가

(heel) , (toe) ,

가

" " " "

1 7 , (10) (12) , ( )  
) (15) (14) (10) 5  
, 1 (12)  
(16) (18) (14) (12) (14) ,  
4,512,577 가 (20) (12)  
(14) (12) ( )  
) (22) , (16) (18) (12)

(22) (23)

(22) 가 (perimeter weighting element, 24)가 , 가  
 (23) (26) 가 (24) (28) (30) (26)  
 (28) , (30) (28) (12)  
 (16) (18) (30) (16)  
 (18) (12) 가 (24) (28)  
 가 (32) , (30) 가 (34), (30)  
 가 (36) (12) (18) (28) (30) (22)  
 (19) , 가 (32) 가 (34)

가 (32) 가 (34) 가 (36) (22) (12) (16)  
 (18) 가 (12) A  
 4,621,813  
 , (30) 가 (34) 가 (36) (40) (38)  
 가 (24) (42) (30) (38)  
 (42) (22) (42)  
 (30) (46) 가 (24) (40)  
 (42) , 가 (36) 가 (34) 가  
 가 (12)

4 6 (12) (22) (48, 50) (48, 50)  
 (16) (19) , 가 8 (48) 가  
 6 (50) (22) [52, 1/8 (3.18mm) ] 48a  
 (52)  
 , (52) (48a) (52) (48a)  
 (10)가  
 ( , ) (52) (48,50) 가  
 (10) (22) " " " "

" " , 가 (48 50 )  
 ( ) (22) ( 5 ) (loft angle)  
 ( ) (22) (52) (48a)  
 ( ) , (52) (10) (48a)

(10) (52) , 5,  
 294,037

11 , 가 (24) (26) (54) . (54)  
 (56) , (56) (58)  
 (60)가 . (58) (10) (center of gravity) (60) . (26)  
 5 (rib; 62, 64, 66, 68 70)가 . (62, 64, 66, 68 70) (58)  
 가 (24) (26) . (62)  
 (12) (18) . (64, 66) (28) , (68, 70) (30)  
 . 10 , (62, 64, 66, 68 70) 가 .

(10) (22) (12) [ , (60)] ,  
 (vibration) . (22) (16) (18)  
 , (62, 64, 66, 68 70), (56) (58) (58)  
 . (62, 64, 66, 68 70), (56) (58) (6  
 2, 64, 66, 68 70) 85% , (56) (58)  
 15% . ,

, (56) , , 6  
 . , (62, 64, 66, 68 70) (24)  
 가 (24) .

, " " " " .

(57)

1.

, , ,  
 , 가 ,  
 ,

가

2.

1 , .

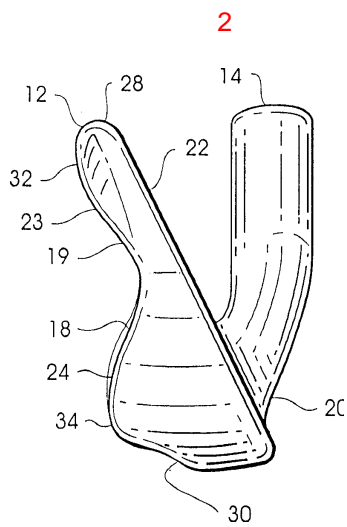
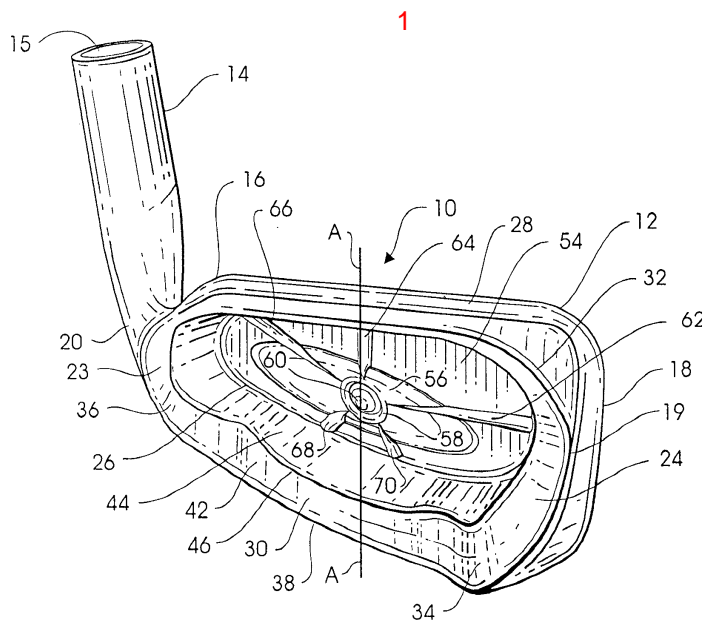

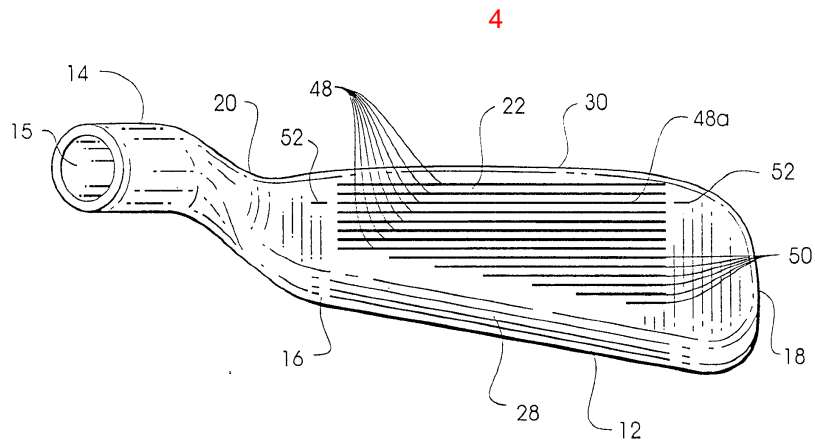
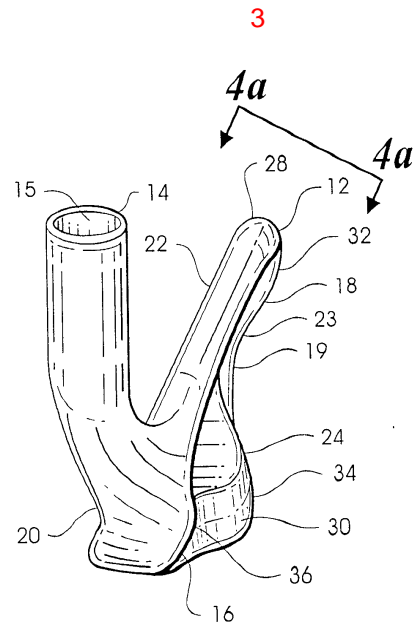

4a

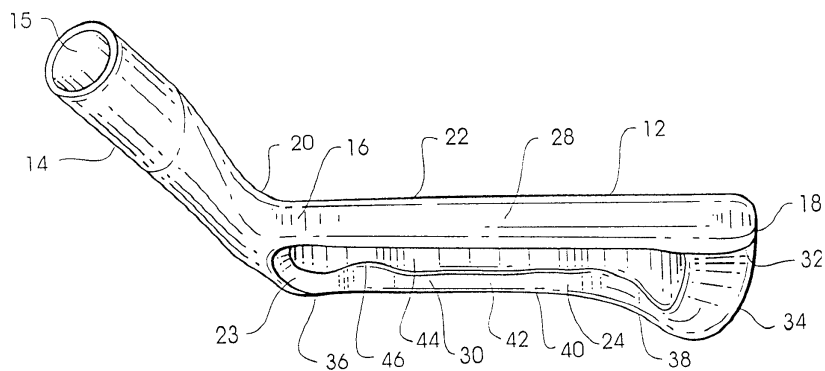

5

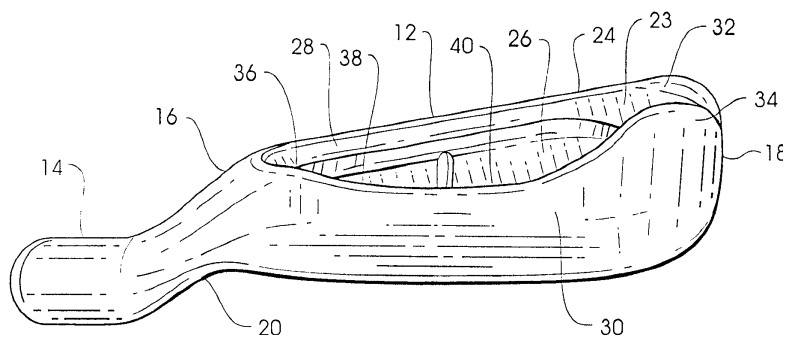

6

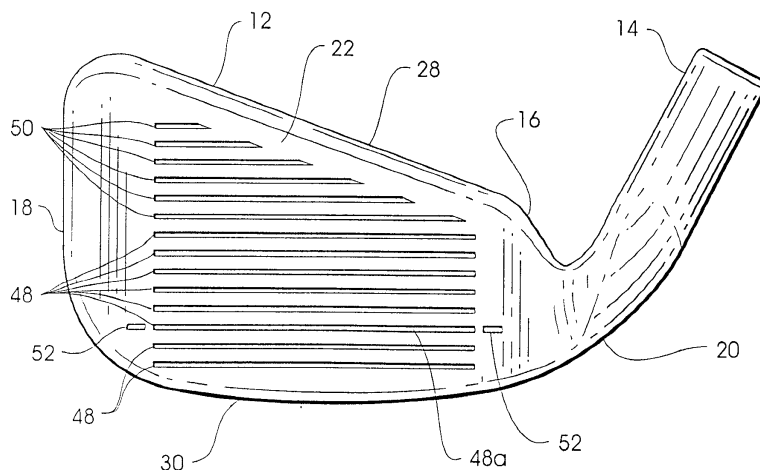



7

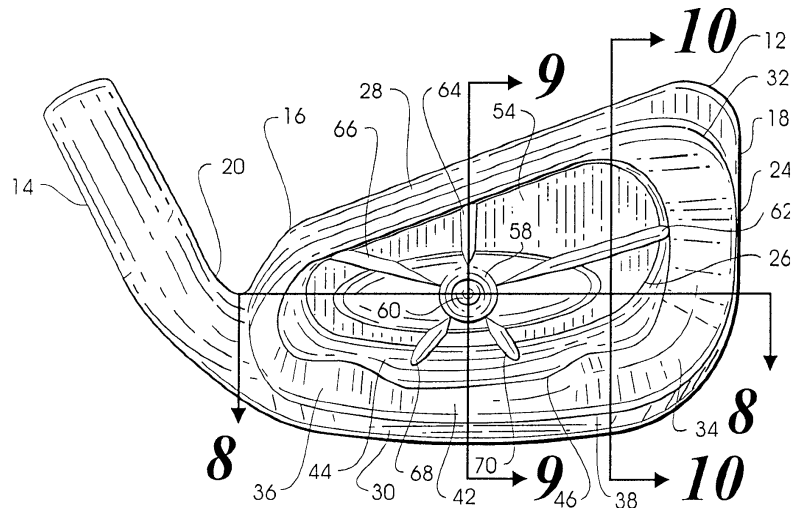

8

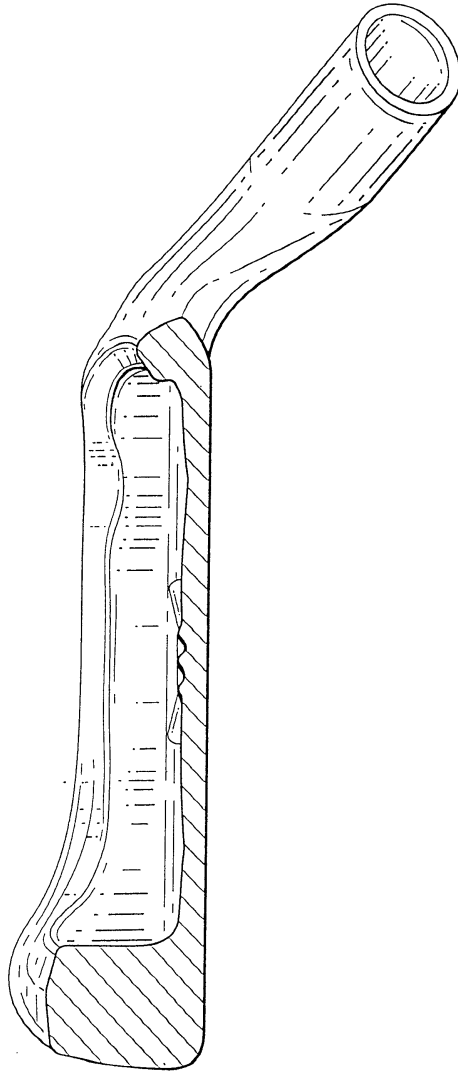

9

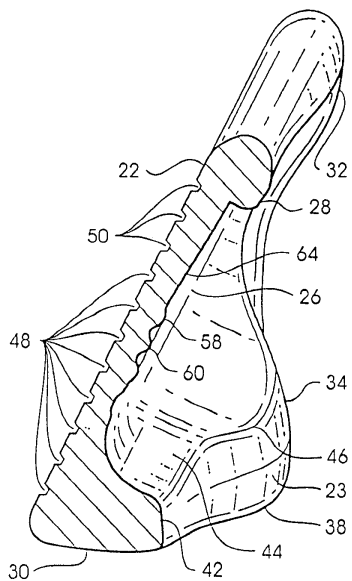

10

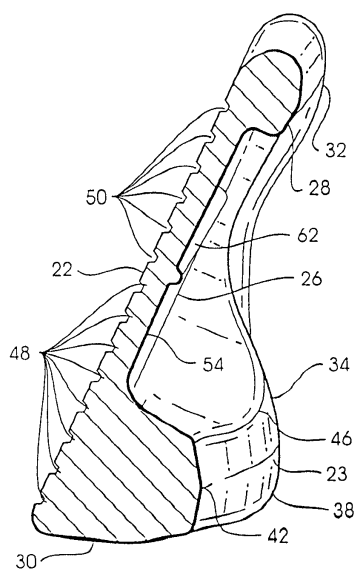

11

