

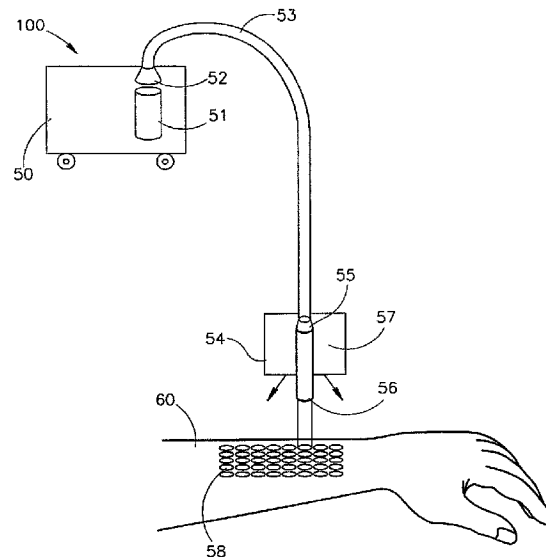

- (72) SLATKINE, Michael, IL  
(72) WALDMAN, Amir, IL  
(72) BRAUDE, Ofer, IL  
(72) ROZENBERG, Zvi, IL  
(72) KLEIN, Arie, IL  
(71) LASER INDUSTRIES LTD., IL  
(51) Int.Cl.<sup>6</sup> A61N 5/06  
(30) 1995/12/18 (60/008,802) US  
(30) 1996/05/12 (118229) IL  
(30) 1996/08/11 (119051) IL  
(54) **ELIMINATION DE POILS PAR PHOTOTHERMOLYSE AU  
MOYEN D'UN LASER A ALEXANDRITE**  
(54) **HAIR REMOVAL BY SELECTIVE PHOTOTHERMOLYSIS  
WITH AN ALEXANDRITE LASER**



(57) L'invention concerne un procédé pour éliminer les poils au moyen d'un laser à alexandrite (50) émettant une énergie comprise entre 0,2 joules et 40 joules par impulsion, avec une fluence énergétique de 15 à 70 joules par centimètre carré, la durée de chaque impulsion étant comprise entre 100 microsecondes et 10 millisecondes. Un scanner (75) peut être utilisé pour diriger le faisceau laser sur le tissu (60). La peau dans la région traitée par le laser peut être rasée avant le traitement et elle peut également être couverte par une substance protectrice servant de puits à chaleur (42).

(57) This invention is a hair removal by using an Alexandrite laser (50) emitting energy between 0.2 joules to 40 joules per pulse to provide an energy fluence between 15 joules and 70 joules per centimeter square, and having a pulse duration of between 100 microseconds and 10 milliseconds. A scanner (57) may be used to direct the laser beam on the tissue (60). The skin in the area to be irradiated may be shaved prior to exposure to laser treatment, and may be also covered by a protective substance serving as a heat sink (42).



PCT

WORLD INTELLECTUAL PROPERTY ORGANIZATION  
International Bureau

## INTERNATIONAL APPLICATION PUBLISHED UNDER THE PATENT COOPERATION TREATY (PCT)

(51) International Patent Classification <sup>6</sup> : A61N 5/06	A1	(11) International Publication Number: WO 97/22384
		(43) International Publication Date: 26 June 1997 (26.06.97)
(21) International Application Number: PCT/IL96/00184	(81) Designated States: AL, AM, AT, AU, AZ, BB, BG, BR, BY, CA, CH, CN, CU, CZ, DE, DK, EE, ES, FI, GB, GE, HU, IL, IS, JP, KE, KG, KP, KR, KZ, LK, LR, LS, LT, LU, LV, MD, MG, MK, MN, MW, MX, NO, NZ, PL, PT, RO, RU, SD, SE, SG, SI, SK, TJ, TM, TR, TT, UA, UG, UZ, VN, ARIPO patent (KE, LS, MW, SD, SZ, UG), Eurasian patent (AM, AZ, BY, KG, KZ, MD, RU, TJ, TM), European patent (AT, BE, CH, DE, DK, ES, FI, FR, GB, GR, IE, IT, LU, MC, NL, PT, SE), OAPI patent (BF, BJ, CF, CG, CI, CM, GA, GN, ML, MR, NE, SN, TD, TG).	
(22) International Filing Date: 18 December 1996 (18.12.96)		
(30) Priority Data: 60/008,802 18 December 1995 (18.12.95) US 118229 12 May 1996 (12.05.96) IL 119051 11 August 1996 (11.08.96) IL		
(71) Applicant: LASER INDUSTRIES LTD. [IL/IL]; Atidim Science Based Industrial Park, Neve Sharett, P.O. Box 13135, 61131 Tel Aviv (IL).	<b>Published</b> <i>With international search report. Before the expiration of the time limit for amending the claims and to be republished in the event of the receipt of amendments.</i>	
(72) Inventors: SLATKINE, Michael; 59 Brenner Street, 46427 Herzlia (IL). WALDMAN, Amir; 20 Revi Street, 45296 Hod Hasharon (IL). BRAUDE, Ofer; 189 Aluf David Street, 52222 Ramat Gan (IL). ROZENBERG, Zvi; 2 Hashikma Street, 90805 Mevasseret Zion (IL). KLEIN, Arie; 34 Hagalil Street, 44233 Kfar Saba (IL).		
(74) Agent: A. TALLY EITAN-ZEEV PEARL & CO.; Law Offices, Lumir House, 22 Maskit Street, 46733 Herzlia (IL).		

(54) Title: HAIR REMOVAL BY SELECTIVE PHOTOTHERMOLYSIS WITH AN ALEXANDRITE LASER

## (57) Abstract

This invention is a hair removal by using an Alexandrite laser (50) emitting energy between 0.2 joules to 40 joules per pulse to provide an energy fluence between 15 joules and 70 joules per centimeter square, and having a pulse duration of between 100 microseconds and 10 milliseconds. A scanner (57) may be used to direct the laser beam on the tissue (60). The skin in the area to be irradiated may be shaved prior to exposure to laser treatment, and may be also covered by a protective substance serving as a heat sink (42).

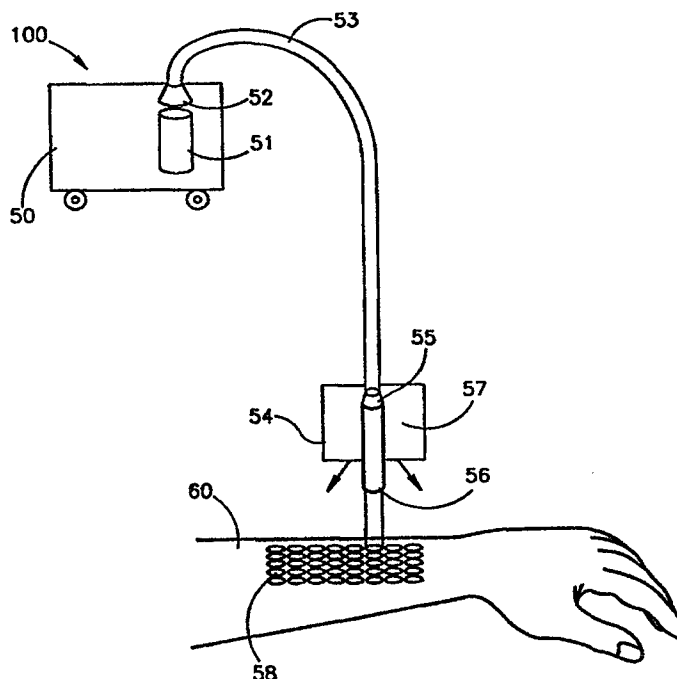

## HAIR REMOVAL BY SELECTIVE PHOTOTHERMOLYSIS WITH AN ALEXANDRITE LASER

5

### FIELD OF THE INVENTION

The present invention relates to laser surgery apparatus and method to remove hair that directs pulsed laser beams from an Alexandrite laser to a protective substance that protects an external surface of skin against damage from overheating and that provides markings to indicate where the impingement takes place.

10

### BACKGROUND OF THE INVENTION

Treatment of skin with lasers have been the subject of study since the early 1960s. A variety of lasers have been used in dermatologic practice. Different lasers are primarily distinguished by a wavelength of the light produced, measured in nanometers, such as the XeF excimer (351 nm), argon (488 nm, 514 nm), ruby (694 nm), Nd:YAG (1060 nm), and CO<sub>2</sub> (10,600 nm) lasers.

15

Photothermolysis of skin has been demonstrated using dye laser pulses and Q-switched ruby laser pulses. It has been found that radiation from Q-switched ruby lasers deeply penetrates the epidermis and dermis. It has also been found that application of ruby red laser energy can cause depigmentation of the skin as well as significant follicular damage to the extent that the hair will fall out.

20

The Q-switched ruby laser has been used for the treatment of tattoos, pigmented lesions, and conventional ruby lasers have been used to treat epidermal and dermal pigmented lesions. Studies based on experimentation with Q-switched ruby lasers, as well as other lasers, have reported skin depigmentation and temporary hair loss.

25

The use of lasers for non-invasive hair removal has been disclosed in U.S. Patent No. 5,059,192, issued October 22, 1991 to Nardo Zaias, entitled METHOD OF HAIR DEPILATION. This patent teaches the use of a pulsed ruby laser as the preferred embodiment. The ruby laser radiation (694 nm wavelength) penetrates deep into tissue and is relatively well absorbed by melanin to cause thermal damage to dark, melanin rich hair shafts and follicles.

30

U.S. Patent No 5,226,907, issued July 13, 1993 to Nikoli Tankovich, entitled HAIR REMOVAL DEVICE AND METHOD and U.S. Patent No. 5,425,728,

35

issued June 20, 1995 to Nikoli Tankovich, entitled HAIR REMOVAL AND METHOD teach the use of a CO<sub>2</sub> pulse laser and a Nd:YAG laser, among other types of lasers, to effect hair removal in conjunction with light absorbing oil used to stain hair.

5           The Nd:YAG laser is limited to relatively low energy levels at affordable commercial production costs. It is effective only for highly absorptive hairs, usually stained for this purpose. Energy levels adequate for hair removal with bare hairs makes it impractical to use an Nd:YAG laser.

10           Large pulsed ruby lasers are capable of delivering very high energy levels -- as high as 40J. As a result, they can attain the energy fluences of 15 - 70J/cm<sup>2</sup> necessary for hair removal. However, ruby lasers can be fired only at a very low repetition rate -- approximately 1 pulse per second (pps). This limits the benefit of using a scanner such as that described in U.S. Patent No. 5,411,502 to Eliezer Zair and the computerized pulsed generator (CPG) scanner, commercially  
15           available from Coherent Inc. of California, USA. This low repetition rate is too low to cover large treated areas as legs and hands in a reasonable time. A 10 x 30cm<sup>2</sup> area (one leg) would require some 1200 pulses, each pulse covering an area of 0.25cm<sup>2</sup> (typical for hair removal with a 5 Joules laser). Assuming a repetition rate of 1pps, this leads to 20 minutes for a single leg, or over 1 hour for  
20           two legs and two hands. This considerably limits the number of patients treatable for hair removal with the expensive laser.

          Another drawback of pulsed ruby lasers is their limited pulse time duration. Ruby lasers operated in their free running modes can usually attain a maximum time duration of 300-1000 microseconds. Extending the pulse duration to 1 - 10  
25           milliseconds is almost impractical. On the other hand, it would be desirable to operate ruby lasers at pulse durations of 1 - 10 milliseconds in most cases of hair removal because of hair follicle diameters being of over 100 microns.

          A third drawback of ruby lasers is their size due to their low efficacy. A 5 Joules, 1pps ruby laser may typically be of 150cm x 70cm x 70cm size. A 25  
30           Joule laser may weigh over 400 kilograms.

          U.S. Patent No. 5,290,273, issued March 1, 1994 to Oon Tan, entitled LASER TREATMENT METHOD FOR REMOVING PIGMENT CONTAINING LESIONS FROM THE SKIN OF A LIVING HUMAN and U.S. Patent No. 5,217,455, issued June 9, 1993 to Oon Tan, entitled LASER TREATMENT  
35           METHOD FOR REMOVING PIGMENTATIONS, LESIONS, AND

ABNORMALITIES FROM THE SKIN OF A LIVING PERSON, teach the use of an Alexandrite laser instead of a ruby laser to treat pigmentation, lesions and skin abnormalities. Both teach that before and after irradiation, the area irradiated should be checked for the presence of absence of adhexac (skin appendages) such as hairs. If a hair loss condition is observed, then the energy density from the laser radiation should be decreased for subsequent treatments. The pulse duration is 10-300 nanoseconds.

Skin treatment employing laser based systems, usually pulsed laser based systems is well known in the art. Such laser based systems are used inter alia for cutaneous vascular lesions treatment and for hair removal, the latter application being described for example in U.S. Patents Nos. 5,059,192 to Zais and 5,226,907 to Tankovich.

As is also well known in the art, the operation of laser based systems for cutaneous treatment is more effective when the tissue is cooled. Examples for prior art devices for cooling the skin during laser treatment are U.S. Patent 5,057,104, U.S. Patent 5,282,797 and U.S. 5,486,172 to Chess specifically designed for cutaneous vascular lesions treatments and U.S. Patent No. 5,344,418 to Ghaffari.

A major disadvantage of prior art laser based systems for cutaneous treatment is that the operation of the laser is not visible to the physician carrying the treatment, thus he can not be sure that the laser covered the entire area to be treated. This results in an inhomogeneous treatment of the skin, such as an inhomogeneous removal of hair from the patient skin in the case of hair removal treatment.

### SUMMARY OF THE INVENTION

One aspect of the invention is to generate at least one pulsed Alexandrite laser beam that travels in a path to a hair follicle. The beam is of sufficient energy and pulse duration to damage hair follicle papilla.

Another aspect of the invention is to provide a protective substance in the path to help protect an external surface of the skin against overheating otherwise arising from the pulsed laser beam.

For non-invasive surgery, this protective substance may be a cooling gel applied to the external surface of the skin to cool the external surface and thereby prevent overheating. For invasive surface, this protective substance may be energy absorbing or reflecting particles that block the laser radiation from penetrating to the external surface of the skin.

Preferably, a plurality of markings are provided that indicate the locations on which the laser beam impinges. The markings may each vaporize upon impingement of a laser beam thereupon or be spaced away so that the laser beam will not impinge them.

The protective substance may cool the skin during laser treatment. This substance may be contained within an enclosure which in turn may have thereon the markings. The enclosure is flexible preferably formed substantially of polyethylene, polypropylene or polycarbonate. This enclosure may have a peelable cover so as to enable direct contact between the gel and the area of the skin of a patient. Preferably, the edge of the enclosure exposed by peeling the peelable cover includes an adhesive material for attaching the enclosure to the patient skin.

The markings may be physically placed on the area of the skin to be treated or adjacent thereto or the markings may be placed over the area of the skin to be treated such as on a transparent sheet disposed intermediate the laser beam and the skin. Alternately, the markings may be projected onto the area of the skin to be treated.

### BRIEF DESCRIPTION OF THE DRAWINGS

For a better understanding of the present invention, reference is made to the following description and accompanying drawings, while the scope of the invention is set forth in the appended claims.

5 Fig. 1 is a cross-sectional view of three hair shafts showing the stages of the hair cycle;

Fig. 2 is a cross-sectional view of a hair follicle after the top has been cut, but prior to application of laser pulse;

10 Fig. 3 is a cross-sectional view of the follicle of FIG. 2 after laser treatment, showing the damaged hair germ;

Fig. 4 is a schematic representation showing the impingement and skin penetration with an Alexandrite laser beam in effecting hair removal;

Fig. 5A shows a schematic pictorial representation of a hair follicle;

15 Fig. 5B shows a graph representing the results of a computer simulation of photothermolysis with an Alexandrite laser beam, aligned with the follicle of Fig. 5A;

Fig. 6 is a graphical representation of the absorption spectrum of melanin and oxyhemoglobin;

20 Fig. 7 is a schematic representation of the beam of an Alexandrite laser interacting with tissue in accordance with the invention;

Fig. 8 is a schematic representation of an Alexandrite laser apparatus for hair depilation according to the present invention;

25 Figs. 9A and 9B are schematic representations of arrangements showing a plurality of markings in accordance with two alternative embodiments of the invention;

Figs. 10A - 10C are schematic representations of progressive views illustrating the operation of the apparatus of Fig. 9A;

Fig. 11A is a schematic representation of a cooling apparatus in accordance with an embodiment of the invention;

30 Fig. 11B is a schematic representation of a cooling apparatus in accordance with another embodiment of the invention;

Fig. 12 is a schematic representation of a system for hair removal in accordance with still another embodiment of the invention;

35 Fig. 13 is a schematic representation of a marking projection system in accordance with a further embodiment of the invention;

Fig. 14A is a schematic representation of a cooling apparatus in accordance with yet another embodiment of the invention; and

Fig. 14B illustrates the cooling apparatus of Fig. 14A in operation.

5

### DESCRIPTION OF THE PREFERRED EMBODIMENT

Fig. 1 shows a hair shaft 10 which has been cut down near the surface of the skin 12. The shaft 10 extends down to the follicle 14 which at the anagen stage of the hair cycle joins the papilla 16. Destruction of the papilla 16 is necessary to prevent hair regrowth.

10

After growing for a period of time that is different for different parts of the human body in the anagen stage, the hair shaft 10 enters the catagen stage represented by hair shaft 20 wherein the papilla 22 separates from the base of the follicle 24. The catagen stage lasts only a few weeks.

15

Hair shaft 30 represents the telogen stage of the hair cycle wherein the papilla 32 completely separates from the follicle 34 and forms a new secondary hair germ which will repeat the cycle. The telogen stage also lasts for a period of time that depends on the part of the body. For arms, it is about three months.

To assure sufficient injury to the papilla 32 at the telogen stage as well as the papilla 16 at the anagen stage, use of a laser with sufficient energy and depth of penetration is necessary to achieve sufficient melanosomal destruction. Cutting of the hair shaft down to the skin 12 in advance of lasing provides two important functions of the treatment process. First, the tip 18 of the hair shaft 10 allows the laser operator to position the laser substantially vertically over the hair follicle opening such that an optimum location for aiming the laser pulse to strike the papilla 16 is obtained. Second, the reduction of excess hair eliminates additional scattering and absorption of other radiant energy contained in the pulse.

25

Fig. 2 shows an enlarged view of the hair shaft 10 prior to treatment, wherein the follicle 14 and papilla 16 are normal in appearance in the anagen stage.

30

Fig. 3 shows the treatment after the laser pulse has been applied to the follicle 14 and the resulting effect on the papilla 16.

Application of the laser pulse to the follicle and the papilla causes photothermolysis which provides melanosomal disruption, including vaporization

35



of the melanin in the follicle 14 and papilla 16, as well as vacuolation, edema, gas bubbles and protein denaturation. When the pulse applied is of sufficient energy level, these effects seriously injure the hair follicle and papilla, thereby damaging the hair germ which causes hair regrowth. The hair follicle 14 may extend into the  
5 reticular dermis up to 3 mm from the skin surface.

Turning to Fig. 4, the use of an Alexandrite laser beam 44 (see Fig. 7) is shown for non-invasive hair removal by selective photothermolysis.

In accordance with the process of selective photothermolysis, the pulse duration time should be shorter than the thermal relaxation time of the follicle.  
10 The thermal relaxation time is defined as the time it takes for a structure to cool to 50% of its peak temperature immediately after laser exposure. The calculated thermal relaxation time for hair shafts and follicle has been found to be approximately 1 - 10 milliseconds.

Figs. 5A and 5B show a computer simulation that is based on a "MONTE  
15 CARLO" statistical model of light scattering in the skin, see M.J.C. Van Gemet et al., "Skin Optics", IEEE translation on Biomedical Engineering, Vol. 36, pp. 1146-1150 (1989). The temperature distribution shows follicle destruction.

Fig. 5A illustrates a schematic cross section in a hair follicle. Fig. 5B illustrates a graph of the simulated energy density distribution curve. The  
20 horizontal axis of the graph represents the value of the simulated energy density. The vertical axis of the graph represents the depth within the skin and is roughly aligned with the cross section of the follicle of Fig. 5A. The numbers along the curve of the graph of Fig. 5B roughly represent the simulated temperature at the corresponding depth values along the vertical axis of the graph.

25 Different types of hair and hair color will require variations in the energy dosage to effect permanent hair removal. Generally, darker hair will induce higher light absorption, therefore a lower dosage may be required.

As shown graphically in Fig. 6, the Alexandrite laser emits radiation at  
30 755 nm. Its emitted beam absorption in tissue is higher than with a ruby laser (approximately 4 times higher). As a result, general tissue heating is higher, which may necessitate tissue cooling in contrast to the case of superficial heating with a ruby laser. Also, melanin absorption of Alexandrite laser radiation is lower than for ruby laser radiation, thus reducing the amount of hair shaft heating and thus laser effectiveness. However, such advantages of the ruby laser tissue  
35 effects over the Alexandrite laser tissue effects is offset by the very high energy

levels attainable with small size, high repetition rate attainable with Alexandrite lasers.

5 According to an alternative embodiment of the present invention, the Alexandrite laser energy is absorbed at least partly by a stain added to the hair itself or by a stained lotion introduced into the hair follicle. The stain or stained lotion absorbs in the 755 nm wavelength. Such a stain or stained lotion may, for instance, be black or blue but not the color of the Alexandrite frequency of near infrared.

10 The following table provides a qualitative comparison between Alexandrite and ruby laser for use for hair removal.

**QUALITATIVE COMPARISON BETWEEN ALEXANDRITE  
AND RUBY LASER FOR HAIR REMOVAL**

	TECHNOLOGY		
5	LASER	RUBY	ALEXANDRITE
	COLOR	RED (694 NM)	INFRARED (755 NM)
	ENERGY PER PULSE WITH A SMALL- MEDIUM SIZE LASER	LOW	HIGH
	MAXIMUM PULSE DURATION IN FREE RUNNING MODE	UP TO 1 MILLISECOND (PRACTICAL)	LONGER (BETTER FOR HAIR REMOVAL)
10	<hr/> TISSUE INTERACTION <hr/>		
	HAIR REMOVAL CAPABILITY	GOOD	GOOD
	DAMAGE TO EXTERNAL SKIN LAYER	HAVE TO BE CAREFUL WITH DARKER SKIN	SMALLER RISK TO DAMAGE DARKER SKIN - HIGHER ABSORPTION BY BLOOD VESSELS
15	<hr/> TREATMENT STRATEGY AND ECONOMY <hr/>		
	USE OF A SCANNER	NO NEED; MANUAL WORK	ADVANTAGEOUS
	COOLING REQUIREMENT	STRINGENT ONLY FOR EPIDERMIS	CONSIDERABLY LESS STRINGENT FOR EPIDERMIS. NEED FOR DERMIS
	SPEED OF PROCEDURE	VERY SLOW	VERY FAST
	POSSIBLE NUMBER OF PATIENTS PER DAY	SMALL	LARGE

20

Turning to Fig. 7, the laser delivery system 40 delivers a fast repetition rate pulses of laser radiation to the tissue that has been previously shaved.

Preferably, the laser beam strikes the surface of the tissue substantially at a perpendicular angle thereto.

In accordance with the preferred embodiment, provision is made to protect the skin from overheating due to radiation from pulsed laser beams. A protective substance, such as a cooling substance contained in a cooling apparatus 42, is arranged on the skin, interposed between the skin and the laser beams.

The cooling apparatus 42 is placed on the tissue to cool the tissue that is being exposed to irradiation from a high average power Alexandrite laser beam 44. High average power arises from high energy per pulse and high frequency of the pulse repetition rate. In a preferred embodiment, the cooling apparatus includes a gel 46 of a matching optical index of refraction to that of a operative dyed transparency 48 having dielectric dots 49 thereon and covering gel 46. The gel 46, when spread over the skin, should have a minimum thickness of 2-3 millimeters to be effective in protecting the external surface of the skin for about a 50-100 micron depth against overheating from pulsed laser beams. The gel 46 acts as a heat sink, withdrawing heat accumulating in the external surface of skin from the laser energy.

Fig. 8 illustrates a preferred embodiment of an Alexandrite laser apparatus 100 that comprises an Alexandrite laser source 50 including a conventional Alexandrite laser head 51 and a conventional coupling lens 52, a conventional optical fiber 53 connecting the Alexandrite laser source 50 to a conventional pulsed laser beam director 54 that has an imaging lens 55 and an aperture 56 through which the laser radiation is applied. In the preferred embodiment, apparatus 100 also includes a scanner 57 that causes the laser beam to sweep a pattern on the tissue being irradiated so as to irradiate spots 58 on the tissue. Spots 58 may coincide in registry with marks 49 of the cooling apparatus 42.

Fig. 8 also illustrates a modification of the embodiment of Fig. 4. As in the case of the Fig. 4 embodiment, the tissue 60 is shaved to cut hairs otherwise protruding from the surface of the tissue.

The following parameters are recommended for an Alexandrite laser with a fiber delivery system to remove hair from human beings:

Energy Level:	within 100 mJ-20J/Pulse, optimally 10J/Pulse
Repetition Rate:	10 Pulse per second

Pulse Duration: 100 microseconds to 3 milliseconds,  
possibly to 10 milliseconds

Spot Size on Tissue: 4 - 10 mm.

Energy Fluence: 15 - 70J/cm<sup>2</sup>

5 Tissue Cooling: 4°C.

Based on clinical trials with fifty patients on faces, arms, legs, the acceptable results were observed where the hair diameters ranged between 40 microns to 80 microns. These results are for a single treatment of the arm:

30% growth of hairs after 3 months @ 50J/cm<sup>2</sup>

10 50% growth of hairs after 3 months @ 37J/cm<sup>2</sup>

70% growth of hairs after 3 months @ 25J/cm<sup>2</sup>

In the case of two treatments, in some cases only 15% growth was observed after 3 months. Another effect observed during clinical trials is that for the case of some hair growth, the diameter of the hair is about 25 percent smaller than the original. That is, the treatment causes shrinkage in the hair diameter.

15 Reference is now made to Figs. 9A and 9B which illustrate an apparatus having a plurality of markings thereon for tracking a laser beam as it sweeps across tissue, e.g., to remove hairs from a patient's skin. The markings indicate whether the laser beam actually reached a location on the skin corresponding to each marking.

Fig. 9A shows a pattern 100 that comprises a plurality of markings 112 which are preferably, but not necessarily, ordered equidistant from each other. The markings 112 may be black dots that vaporize upon impingement of the laser beam thereupon. Fig. 9B shows a pattern 111 that comprises a grid 113 with each grid junction 115 being analogous to the markings 112. Alternatively, the markings 112 or grid junctions 115 may be arranged so that the laser beam will not be directed to impinge them, e.g., may be spaced neighboring the areas to be impinged.

In the embodiments of Figs. 9A and 9B, patterns 110 and 111, respectively, are each on a respective sheet 114 of transparent material. The transparent material may be polyethylene, polypropylene or polycarbonate. The markings 112 and grid 113 are each made of any suitable identifier, such as ink printed on the sheet 114. In a further embodiment of the present invention, patterns 110 and 111 form part of a cooling apparatus as depicted in Figs. 11B and 12. In yet a further embodiment of the present invention, markings 112 are

marked on the skin. In yet another embodiment, the markings are projected on the skin as illustrated with respect to Fig. 13.

5 Figs. 10A - 10C illustrate the progression of the treatment over time with each successive laser pulse directed to a corresponding successive marking 112 so as to vaporize the markings 112 and the associated hairs 124 thereunder by scanning the laser beam across the tissue 60. After pulsing the laser source 50 a desired number of times onto all the markings 112 or grid junctions 115, substantially full coverage of the area to be treated is attained. In an alternative embodiment, the markings 112 or the grid 113 are used to indicate the vicinity and not the exact location on which the laser beam impinges and therefore are not being vaporized by impingement of the laser beam thereupon. The sheet 114 is placed intermediate the laser source 50 and the patient's tissue 60. Preferably, the sheet extends substantially parallel to the skin tissue 60.

10 Referring now to Fig. 11A, the pattern 110 is illustrated as part of a cooling apparatus 130 so as to further increase the effectiveness of the laser treatment. While the cooling apparatus 130 may be any prior art cooling apparatus, in a preferred embodiment of the present invention, the cooling apparatus 130 comprises a flexible enclosure 132 formed of a relatively thin plastic material, such as polyethylene, polypropylene or polycarbonate, having therein any suitable cooling substance 134. An example of the cooling substance 134 is water, preferably with salt, to decrease its freezing temperature. A transparent sheet 114 with the markings 112 is disposed in enclosure 132 as shown in Fig. 11B. This cooling substance 134 helps protect the skin from thermal damage otherwise arising from pulsed laser beams used in hair removal.

15 A particular feature of the present invention is the use of an ultrasound gel 138, such as the Aquarius 101 Ultrasound gel, commercially available from Meditab Ltd. of Israel. Gel 138 is disposed intermediate the tissue 60 and the cooling apparatus 130. Since enclosure 132 is flexible it is more easy to handle and to place over tissue 60 than a conventional cooling apparatus that is rigid. However, since enclosure 132 need not be necessarily in direct contact with the skin, gel 138 provides the required optical index of refraction matching between the skin and cooling apparatus 130.

20 According to an alternative preferred embodiment of the present invention illustrated in Fig. 11B, a cooling apparatus 131 is substantially similar to the cooling apparatus 130 and therefore similar elements are referenced in Figs. 11A

and 11B by the same reference numerals. Cooling apparatus 131 differs from cooling apparatus 130 in that it also includes gel 138 enclosed within an enclosure 133 having peelable cover 135. In operation, peelable cover 135 is peeled and cooling apparatus 131 is attached to the skin with attachments 137. Preferably, the edge of the enclosure 133 exposed by peeling the peelable cover includes an adhesive material which serves as the attachment 137 for attaching the cooling apparatus to the patient skin.

Cooling apparatus 130 and cooling apparatus 131 are used in conjunction with a laser based skin treatment system, generally referenced 140, illustrated in Fig. 12. Although Fig. 12 is described with respect to cooling apparatus 130, it is equally applicable to cooling apparatus 131.

System 140 includes a laser source 50 operating to provide a pulsed laser beam 44 onto a cooling apparatus 130 and gel 138. In operation, the gel 138 is spread over the area of the skin to be treated and cooling apparatus 130 is placed thereon intermediate gel 138 and laser source 50. A physician (not shown) then operates to treat the skin with the pulsed laser beam 44 as described hereinabove with reference to Figs. 10A through 10C.

While the present invention has been described with respect to markings 112, it is equally applicable to grid junctions 115. Yet another example is to employ a projection apparatus in order to project the markings of the treated area as illustrated in Fig. 13. Fig. 13 shows a light source 150 that projects light through a transparent sheet 152 having markings 154 thereon so as to effectively mark tissue 60 with shade markings 156. Laser 50 operates in the same manner as previously discussed.

Fig. 14A shows a cooling apparatus 160 in which the markings are part of the enclosure and not of a transparent marked sheet disposed therein. The cooling apparatus 160 of Fig. 14A comprises an enclosure 161 of which the top part 162 faces away from the skin during operation. The cooling includes discrete marks 163 or a grid thereon and of which the bottom part is a folded removable cover 164. This cover 164 is removed after the cooling apparatus 160 is attached to the skin with attachments 165. Disposed in enclosure 161 is a gel 166 that is used as the cooling agent during operation of the laser on the skin.

In operation, apparatus 160 is placed on the skin and a peelable cover is pulled out by pulling its edge 167. The gel 166 thus comes into contact with the

area to be treated as shown in Fig. 14B and the laser beam is directed onto the treated area bearing the indicia of the plurality of markings 163.

In an alternative embodiment, the peelable cover 164 is removed before the cooling apparatus 160 is tied to the skin.

5 While the foregoing description and drawings represent the preferred embodiments of the present invention, it will be understood that various changes and modifications may be made without departing from the spirit and scope of the present invention. For example, a colored marking at the edge of any cooling apparatus, such as cooling apparatus 160 may be added such that the cooling apparatus marks the area being treated.

10 For purposes of interpretation of the claims, "markings" covers any form of point indicia, whether ink dots, grid junctions, surface contour indentations or protrusions, etc.

The present invention clearly covers non-invasive hair removal by selective photothermolysis with an Alexandrite laser. However, it also pertains to invasive hair removal with an Alexandrite laser in that a protective substance, such as energy absorbing particles in lotion, fills the hair follicle and effectively blocks laser energy emitting from an invasive laser probe from penetrating to the external layer of the skin. These energy absorbing particles may be carbon black or white reflective that keep the laser energy contained to the hair follicle. In both the invasive and non-invasive techniques, the concept is to pulse the Alexandrite laser and rely on the protective substance to protect the skin against overheating. In this manner, scarring of surrounding tissue from the pulsed laser beam is minimized.

25 While the foregoing description and drawings represent the preferred embodiments of the present invention, it will be understood that various changes and modifications may be made without departing from the spirit and scope of the present invention.



**CLAIMS**

1. A laser surgery apparatus to remove hair, comprising:  
an Alexandrite laser that generates at least one pulsed laser beam that travels in a path and of sufficient energy and pulse duration to damage hair  
5 follicle; and  
a protective substance arranged in said path to help protect an external surface of the skin against overheating otherwise arising from the pulsed laser beam.
2. An apparatus as in claim 1, further comprising markings that are arranged  
10 to provide an indication of where the pulsed laser beam passes through said protective substance, whereby hair follicles that are in the path become damaged by the at least one pulsed laser beam.
3. An apparatus as in claim 1, wherein each of said markings are constructed of a material that vaporizes in response to impingement by the pulsed laser beam.
- 15 4. An apparatus as in claim 1, further comprising a projector that projects the markings onto the protective substance by shining light through a transparent sheet having markings.
5. An apparatus as in claim 1, wherein said markings are responsive to impingement by the pulsed laser beam to provide the indication.
- 20 6. An apparatus as in claim 1, wherein said pulsed laser beam has a pulse duration of 100 microseconds to 10 milliseconds.
7. An apparatus as in claim 1, wherein said Alexandrite laser generates a plurality of pulsed laser beams, further comprising a scanner that directs said pulsed laser beams to sweep across said protective substance in a vicinity of said  
25 markings in accordance with a pattern.
8. An apparatus as in claim 1, further comprising an enclosure containing said protective substance, said enclosure being interposed in said path.
9. An apparatus as in claim 8, wherein said enclosure includes a plurality of sheets of transparent material.
- 30 10. An apparatus as in claim 9, wherein said sheets of constructed of a plastic material selected from the group consisting of polyethylene, polypropylene, polycarbonate, and any combination thereof.
11. An apparatus as in claim 8, further comprising an ultrasound gel within said enclosure.

12. An apparatus as in claim 8, further comprising an ultrasound gel in contact with an exterior of said enclosure.
13. An apparatus as in claim 8, wherein said enclosure is flexible.
14. An apparatus as in claim 1, wherein said markings are selected from the group consisting of inks, light projections, and configurations in said envelope.
- 5 15. An apparatus as in claim 1, wherein said protective substance is an ultrasound gel.
16. An apparatus as in claim 1, wherein any one of stain and stained lotion is in said path such that said protective substance is between said Alexandrite laser and said any one of said stain and stained lotion.
- 10 17. An apparatus as in claim 1, wherein said Alexandrite laser emits energy between 0.2-40 joules per pulse.
18. An apparatus as in claim 1, wherein said Alexandrite laser emits pulsed laser beams with a pulse repetition rate of 1 pulse per second to 15 pulses per second.
- 15 19. An apparatus as in claim 1, wherein said Alexandrite laser provides an energy fluence of between 15 joules per centimeter squared and 70 joules per centimeter squared.
20. An apparatus as in claim 1, wherein said Alexandrite laser provides said pulsed laser beam such that said pulse duration is shorter than a thermal relaxation time of the hair follicle.
- 20 21. A method of laser surgery to remove hair, comprising:  
generating at least one pulsed laser beam that travels in a path from an Alexandrite laser and of sufficient energy and pulse duration to damage hair follicle; and  
25 interposing a protective substance in the path to help protect an external surface of the skin against overheating otherwise arising from the pulsed laser beam.
22. A method as in claim 21, further comprising the step of indicating with markings where the pulsed laser beam passes through the protective substance, whereby hair follicles that are in the path become damaged by the at least one pulsed laser beam.
- 30 23. A method as in claim 22, wherein said markings vaporize in response to the pulsed laser beam impinging said markings.

24. A method as in claim 22, further comprising the step of indicating includes projecting the markings by shining light at the protective substance through a transparent sheet with markings.
25. A method as in claim 22, wherein the step of indicating arises in response  
5 to the pulsed laser beam impinging the markings.
26. A method as in claim 22, wherein said Alexandrite laser generates a plurality of pulsed laser beams, further comprising scanning with the pulsed laser beams to sweep across the cooling substance in a vicinity of the markings in accordance with a pattern.
- 10 27. A method as in claim 21, further comprising enclosing the protective substance within an enclosure, the enclosure being transparent.
28. A method as in claim 21, further comprising contacting the envelope with an ultrasound gel.
29. A method as in claim 21, further comprising flexing said enclosure.
- 15 30. A method as in claim 21, further comprising staining hair and arranging the path so that the pulsed laser beam strikes the stained hair.
31. A method as in claim 21, wherein the Alexandrite laser emits energy between 0.2-70 joules per pulse.
32. A method as in claim 21, wherein the Alexandrite laser generates pulsed  
20 laser beams that have a pulse repetition rate of 1 pulse per second to 15 pulses per second.
33. A method as in claim 21, wherein said Alexandrite laser provides energy fluence of between 15 joules per centimeter squared and 40 joules per centimeter squared.
- 25 34. A method as in claim 21, further comprising the step of shaving hairs and then directing the path of the pulsed laser beam to strike the shaved hairs.
35. A method as in claim 21, further comprising the step of keeping the path away from the markings at all times.
36. A method as in claim 21, wherein the step of generating includes  
30 generating the pulsed laser beam such that the pulse duration that is shorter than a thermal relaxation time of melanin.
37. A method as in claim 21, wherein the step of generating causes the pulsed laser beam to have a pulse duration between 10 microseconds and 10 milliseconds.

38. A method of hair removal, comprising the step of applying at least one Alexandrite laser pulse to at least one hair follicle, said Alexandrite laser pulse having sufficient pulse duration and radiant exposure dose of sufficient energy to damage said at least one hair follicle so that percentage hair growth diminishes and scarring of the surrounding skin is minimized.

39. A method as in claim 34, wherein said pulse duration is between 10 microseconds and 10 milliseconds.

40. A method as in claim 39 wherein said step of applying comprising the steps of:

aligning a laser light applicator over said at least one hair follicle opening in tissue, said applicator having an aperture of sufficient area to surround said at least one hair follicle and overlie its papilla; and

directing through said aperture to said at least one hair follicle said at least one pulse of laser radiation.

41. A method as in claim 38, further comprising the step of absorbing part of said at least one laser pulse with stain that has been added to the one hair follicle.

42. A method as in claim 38, wherein said Alexandrite laser emits energy between 2-70 joules per pulse.

43. A method as in claim 38, wherein said Alexandrite laser emits energy at a pulse repetition rate of 1 pulse per second to 15 pulses per second.

44. A method as in claim 38, wherein said directing comprises directing the laser beam through a scanner to deliver the laser radiation to tissue in a homogenous manner.

45. A method as in claim 38, wherein said Alexandrite laser provides an energy fluence of between 15 joules per centimeter squared and 40 joules per centimeter squared to said at least one hair follicle.

46. A method as in claim 38, wherein each said Alexandrite laser pulse is arranged to irradiate spots on the tissue with the Alexandrite laser, each of the spots having a spot size on the tissue between 3-8 millimeters.

47. A method as in claim 38, wherein the step of applying provides an energy fluence on the tissue that results in a percentage growth of hairs after 3 months that is in accordance with a relationship between percentage growth after 3 months and energy fluence, the relationship being characterized by a curve profile whose coordinates include:

30% growth of hairs after 3 months @ 50J/cm<sup>2</sup>

50% growth of hair after 3 months @ 37J/cm<sup>2</sup>

70% growth of hairs after 3 months @ 25J/cm<sup>2</sup>.

48. A method as in claim 38, wherein the step of applying is such that the pulse duration is shorter than a thermal relaxation time of the melanin.
- 5 49. A method as in claim 38, further comprising the step of shaving the hair follicle before the step of applying so that the hair follicle is free from protruding from the skin to a position that would scatter radiant energy from the laser pulse upon infringement.
- 10 50. An apparatus for hair removal, comprising:
- a. an Alexandrite laser source for generating at least one alexandrite laser pulse having a sufficient pulse duration and radiant exposure dose of sufficient energy to damage at least one hair follicle so that percentage hair growth diminishes and scarring of the surrounding skin is minimized; and
  - 15 b. a laser light applicator that directs said laser pulses to said at least one hair follicle.
- 20 51. An apparatus as in claim 50, wherein said pulse duration is between 100 microseconds and 10 milliseconds.
52. An apparatus as in claim 50 wherein said laser light applicator is aligned over said at least one hair follicle opening in tissue, said applicator having an aperture of sufficient area to surround said at least one hair follicle and overlie its papilla so that said at least one pulse of laser radiation is directed through said aperture to said at least one hair follicle.
- 25 53. An apparatus as in claim 50, further comprising stain arranged so that said stain absorbs at least part of said at least one laser pulse.
- 30 54. An apparatus as in claim 50, wherein said Alexandrite laser emits energy between 0.2-40 joules per pulse.
55. An apparatus as in claim 50, wherein said Alexandrite laser emits energy at a pulse repetition rate of 1 pulse per second to 15 pulses per second.

56. An apparatus as in claim 50, further comprising a scanner operative to deliver the laser radiation via said laser light applicator to tissue in a homogenous manner.
57. An apparatus as in claim 50, wherein said Alexandrite laser provides an energy fluence of between 15 joules per centimeter squared and 70 joules per centimeter squared to said at least one hair follicle.
58. An apparatus as in claim 50, wherein each said laser light application is arranged to direct said laser pulses to irradiate spots on the tissue so that each of the spots has a spot size on the tissue between 3-8 millimeters.
59. An apparatus as in claim 50, wherein said laser source provides a level of energy fluence on the tissue that results in a percentage growth of hairs after 3 months that is in accordance with a relationship between percentage hair growth after 3 months and energy fluence, the relationship being characterized by a curve profile whose coordinates include:
- 30% growth of hairs after 3 months @ 50 J/cm<sup>2</sup>
  - 50% growth of hairs after 3 months @ 37J/cm<sup>2</sup>
  - 70% growth of hairs after 3 months @ 25J/cm<sup>2</sup>.
60. An apparatus as in claim 50, wherein said Alexandrite laser source provides the alexandrite laser pulse such that the pulse duration is shorter than a thermal relaxation time of melanin.

1/10

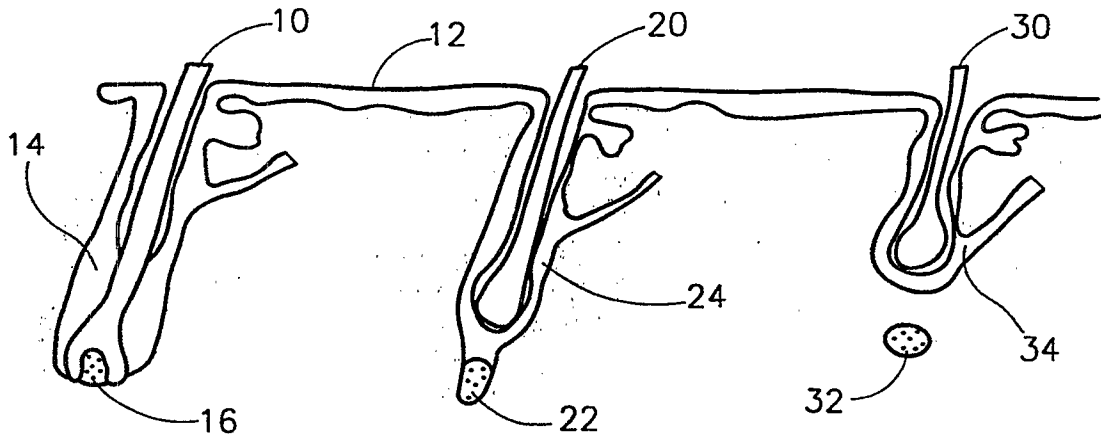

FIG. 1

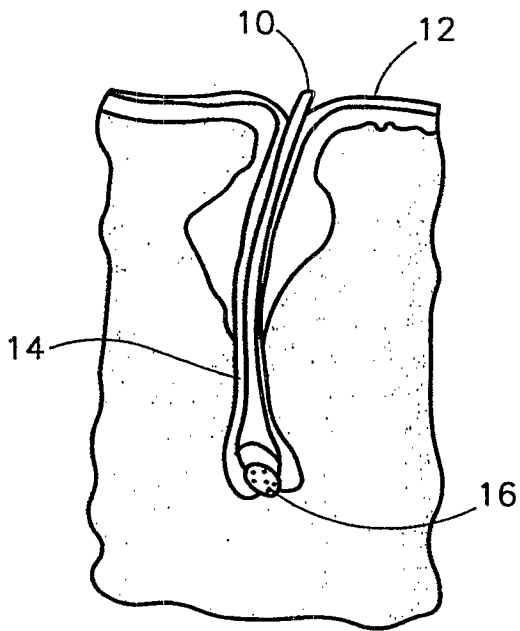

FIG. 2

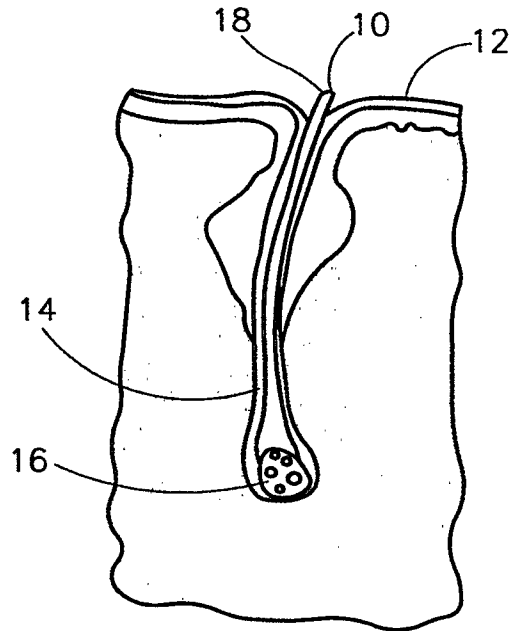

FIG. 3

2/10

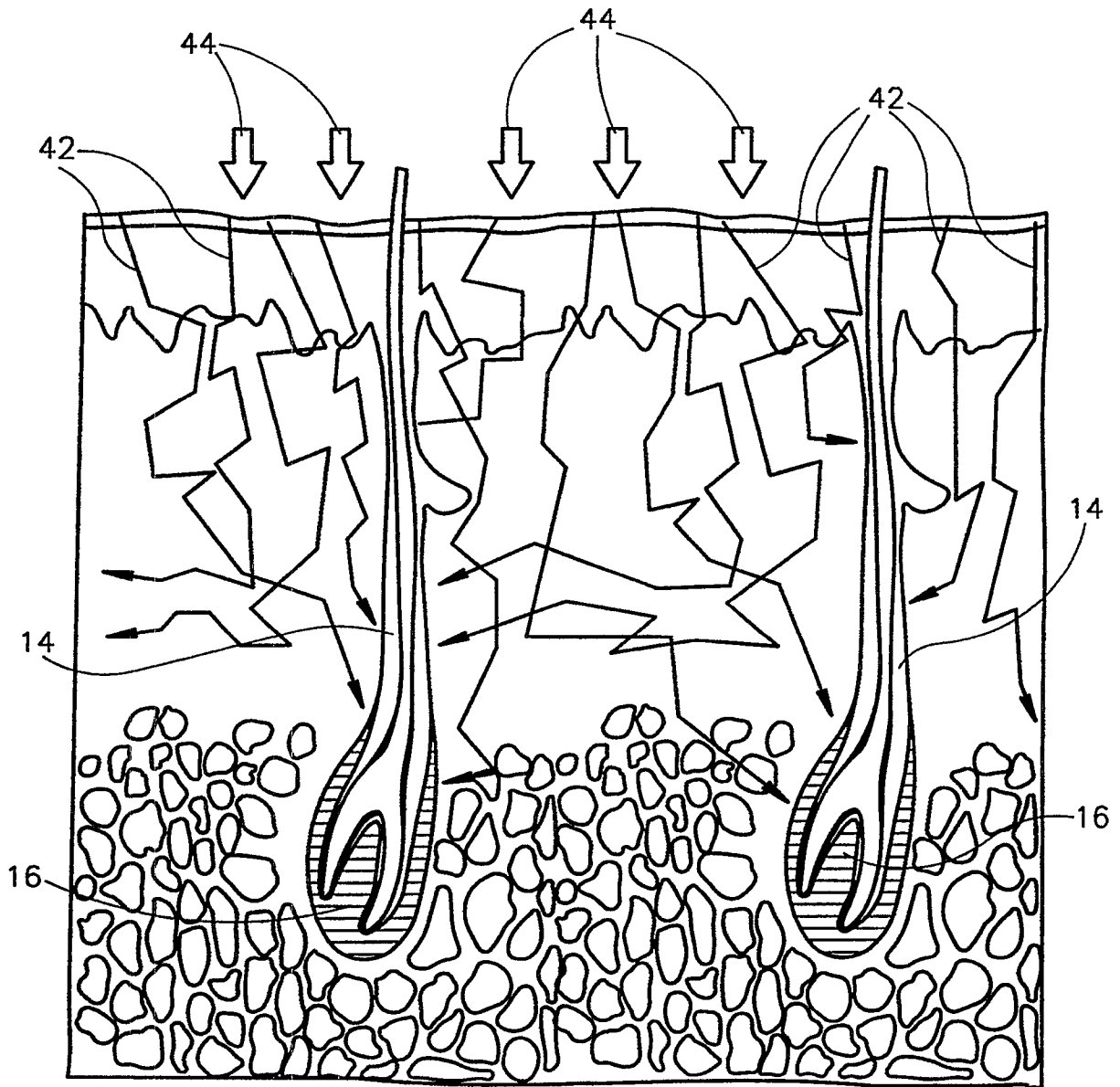
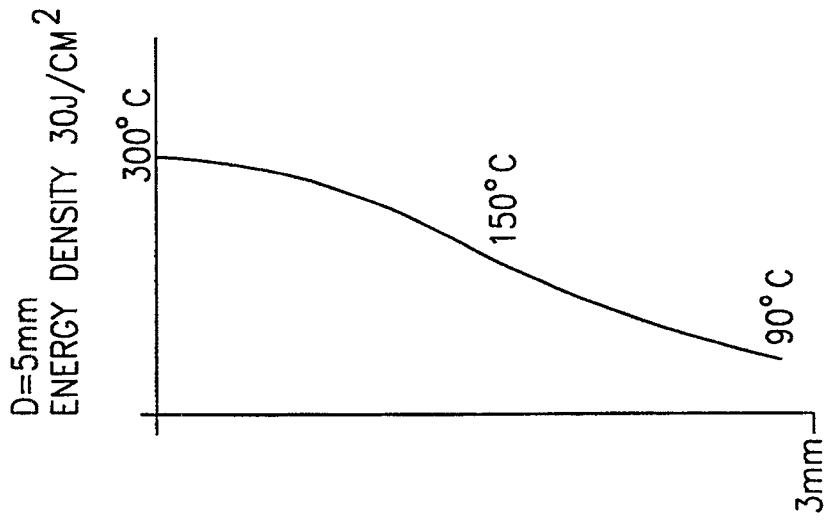
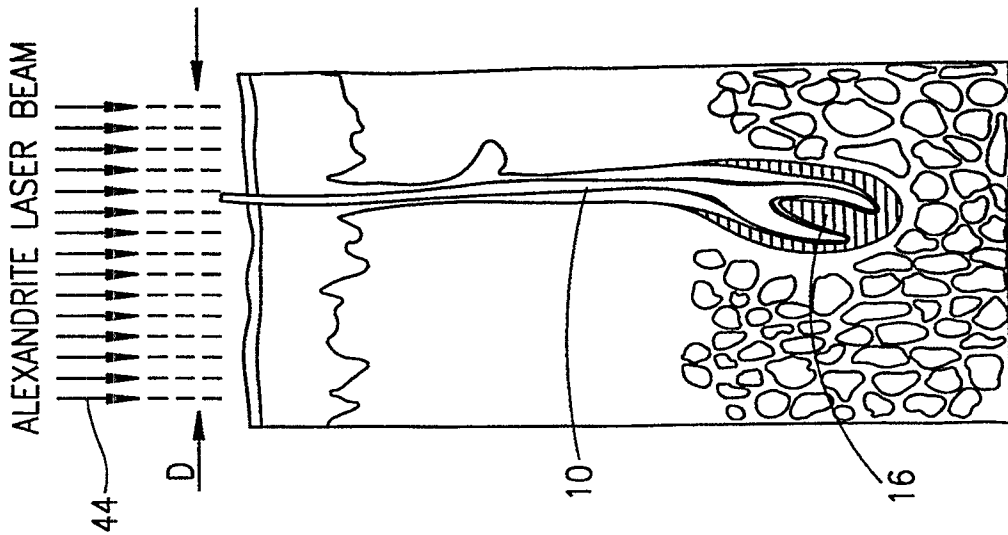

FIG. 4



3/10



HAIR SHAFT DIAMETER: 50 MICROMETER  
 COLOR: BLACK. 100% ABSORPTION

FIG.5A

FIG.5B

4/10

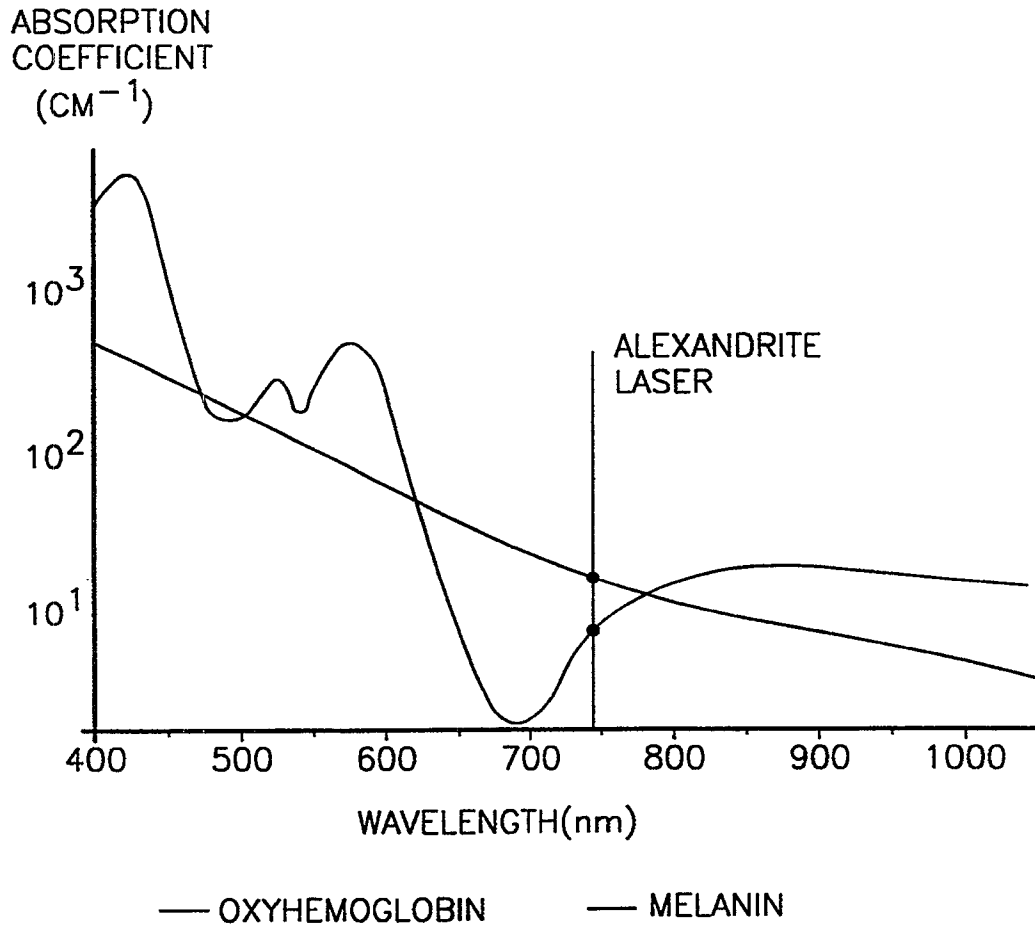

FIG.6

5/10

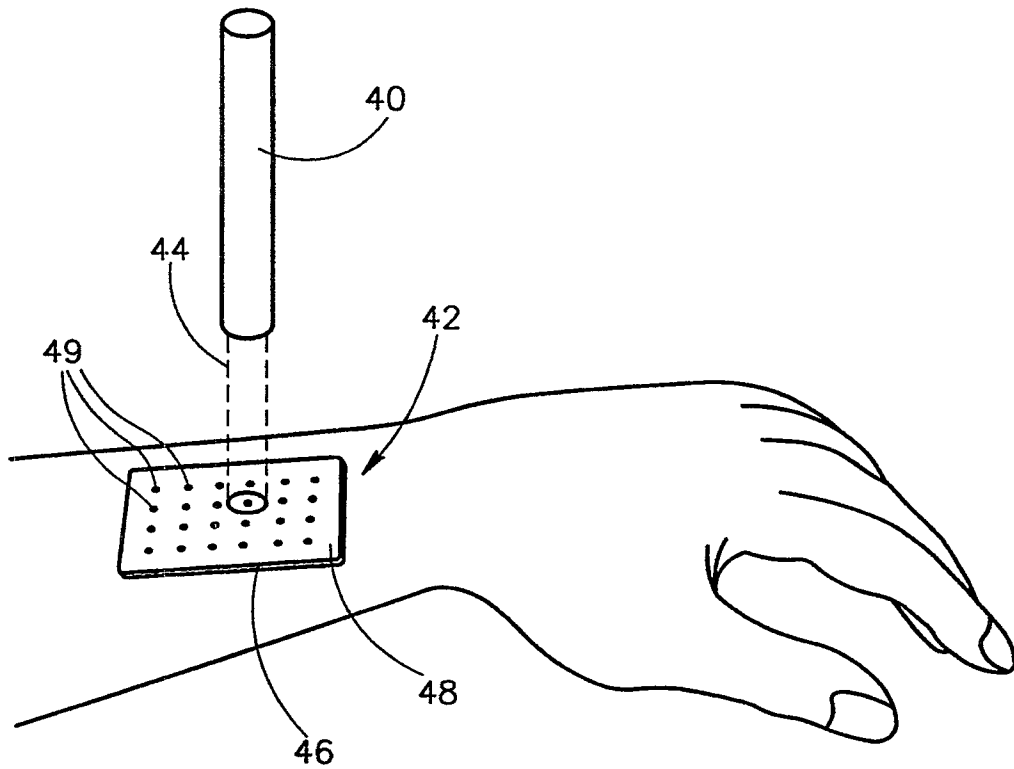

FIG. 7

6/10

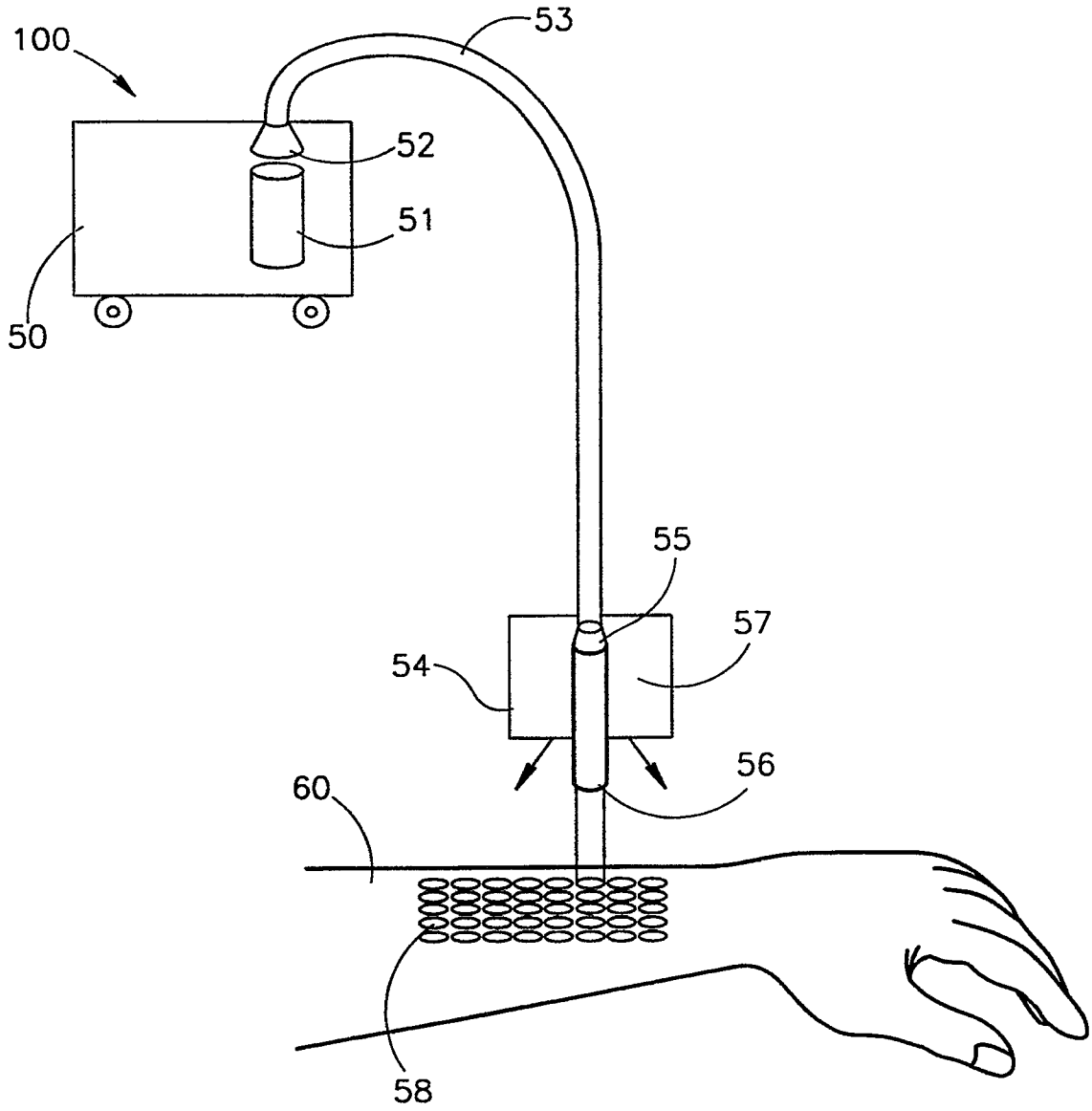
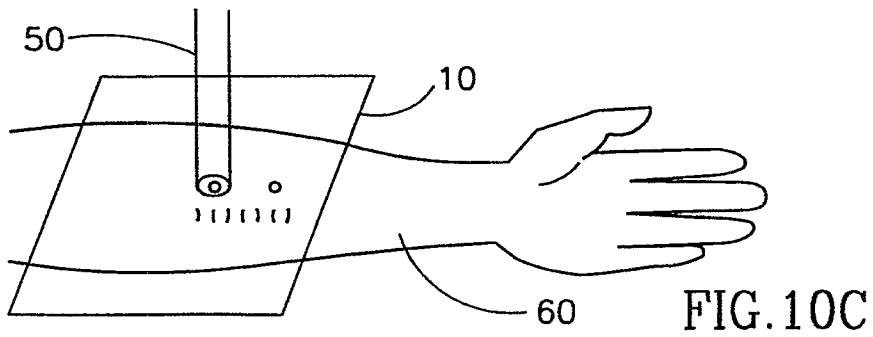
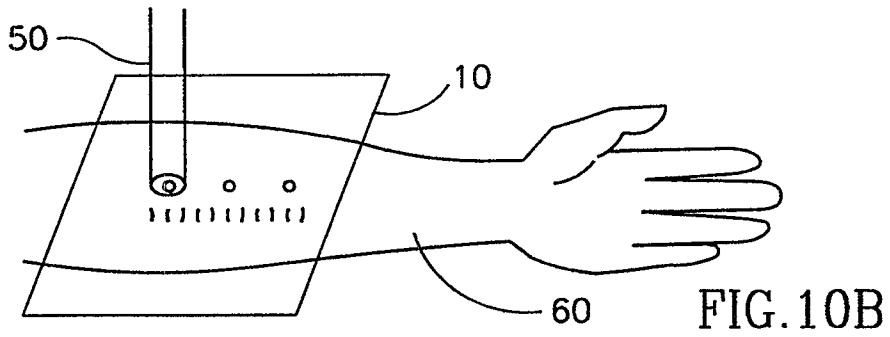
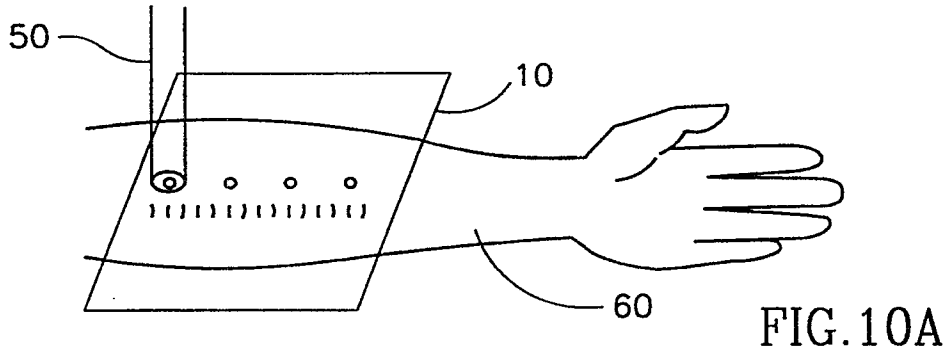
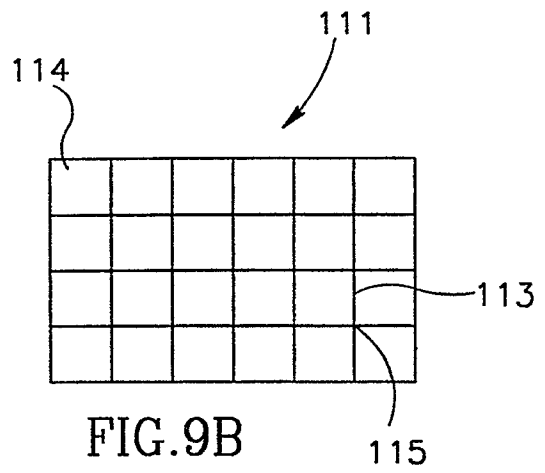
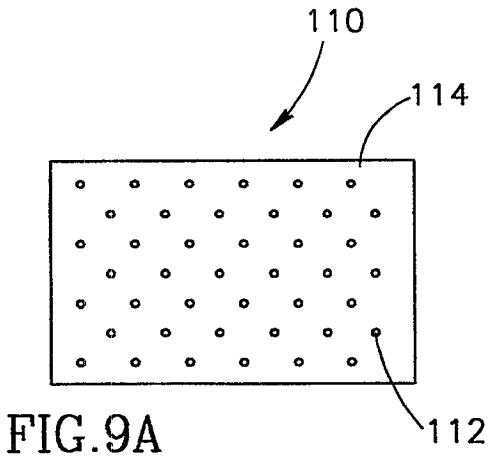

FIG. 8

7/10



8/10

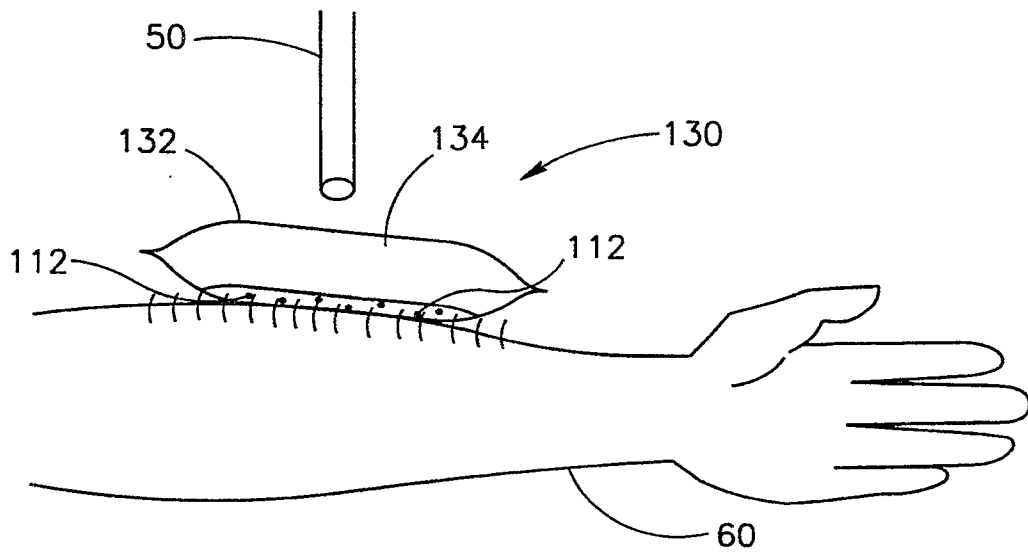

FIG. 11A

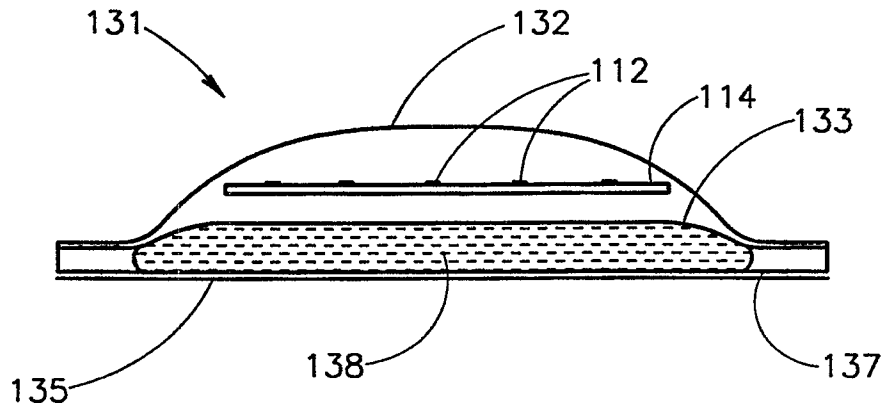

FIG. 11B

9/10

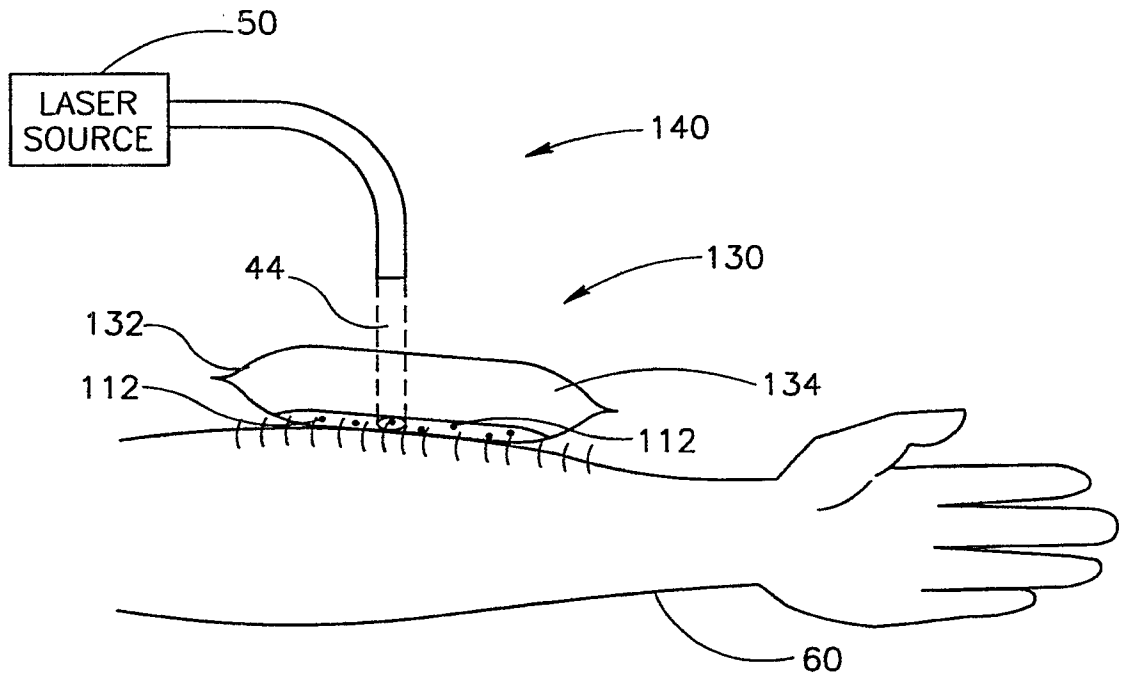

FIG. 12

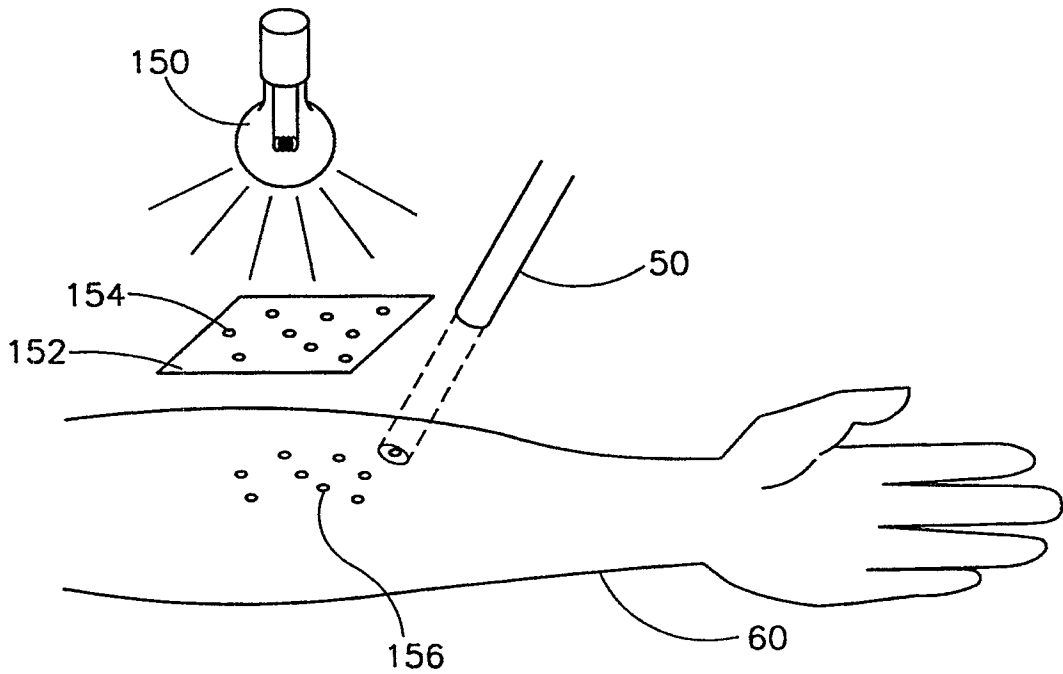

FIG. 13

10/10

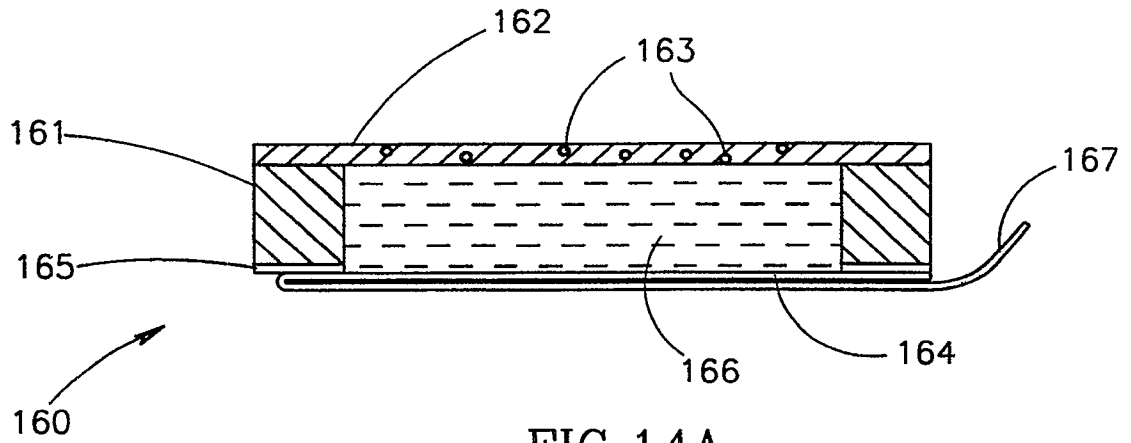

FIG. 14A

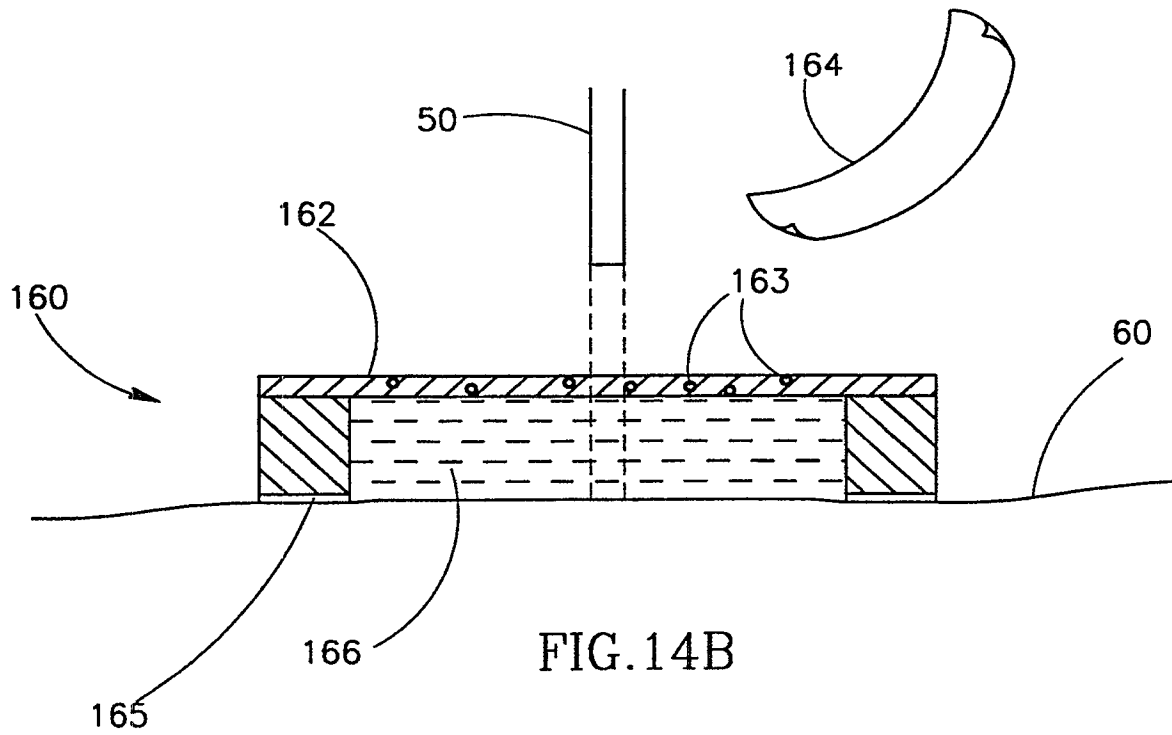

FIG. 14B



