



US 20120246978A1

(19) **United States**

(12) **Patent Application Publication**
Haley et al.

(10) **Pub. No.: US 2012/0246978 A1**

(43) **Pub. Date: Oct. 4, 2012**

(54) **TRENCHER ASSEMBLY AND ASSOCIATED ACCESSORIES**

Publication Classification

(51) **Int. Cl.**
E02F 5/06 (2006.01)
(52) **U.S. Cl.** 37/349
(57) **ABSTRACT**

(76) Inventors: **Thomas L. Haley**, Boyne City, MI (US); **John T. Zell**, Boyne City, MI (US)

(21) Appl. No.: **13/370,857**

(22) Filed: **Feb. 10, 2012**

A trencher assembly for use in association with an excavator and the like, including: a body, wherein the body is configured for releasable securement with a boom, a crumber bar, and a bracket, wherein the boom is associated with an endless chain having a plurality of teeth and/or blades; a crumber bar, wherein the crumber bar extends contiguously from the body, and further wherein the crumber bar is positioned generally above the boom; and a bracket, wherein the bracket is configured for releasable securement to both the body of the trencher assembly, as well as an excavator. Accessory items releasably securable to the brackets of the present invention are also provided.

Related U.S. Application Data

(60) Provisional application No. 61/441,333, filed on Feb. 10, 2011.

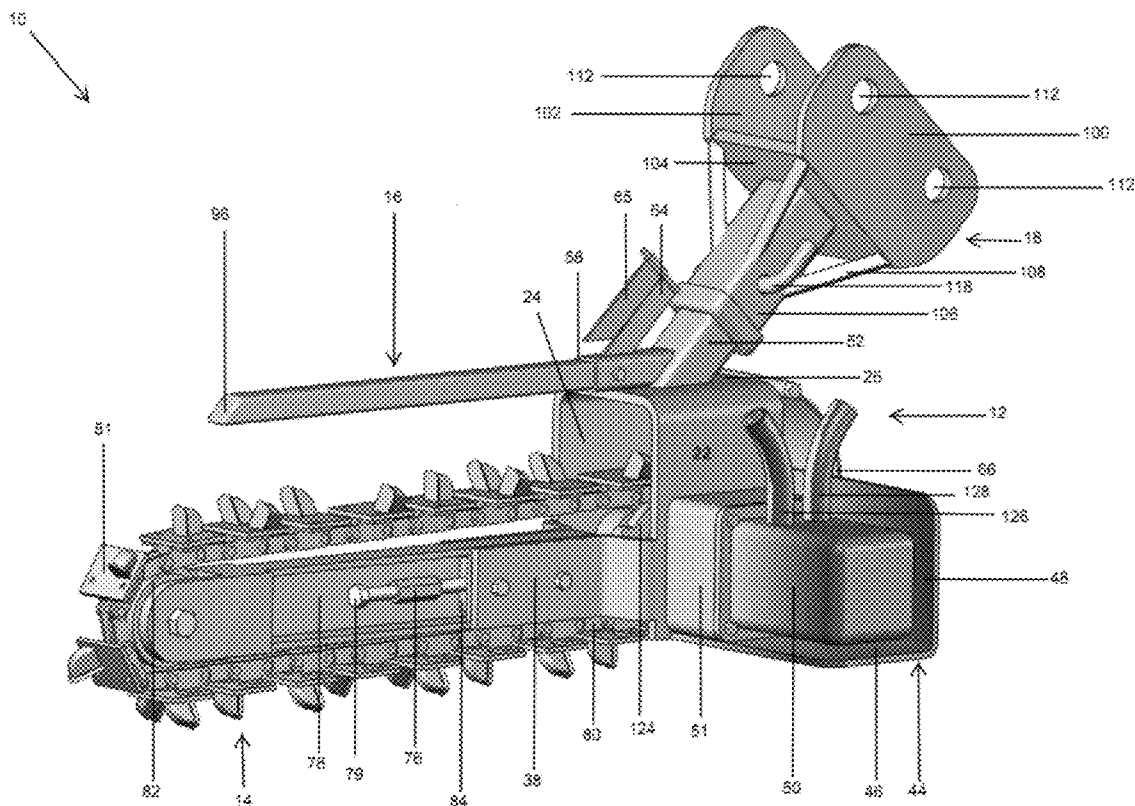

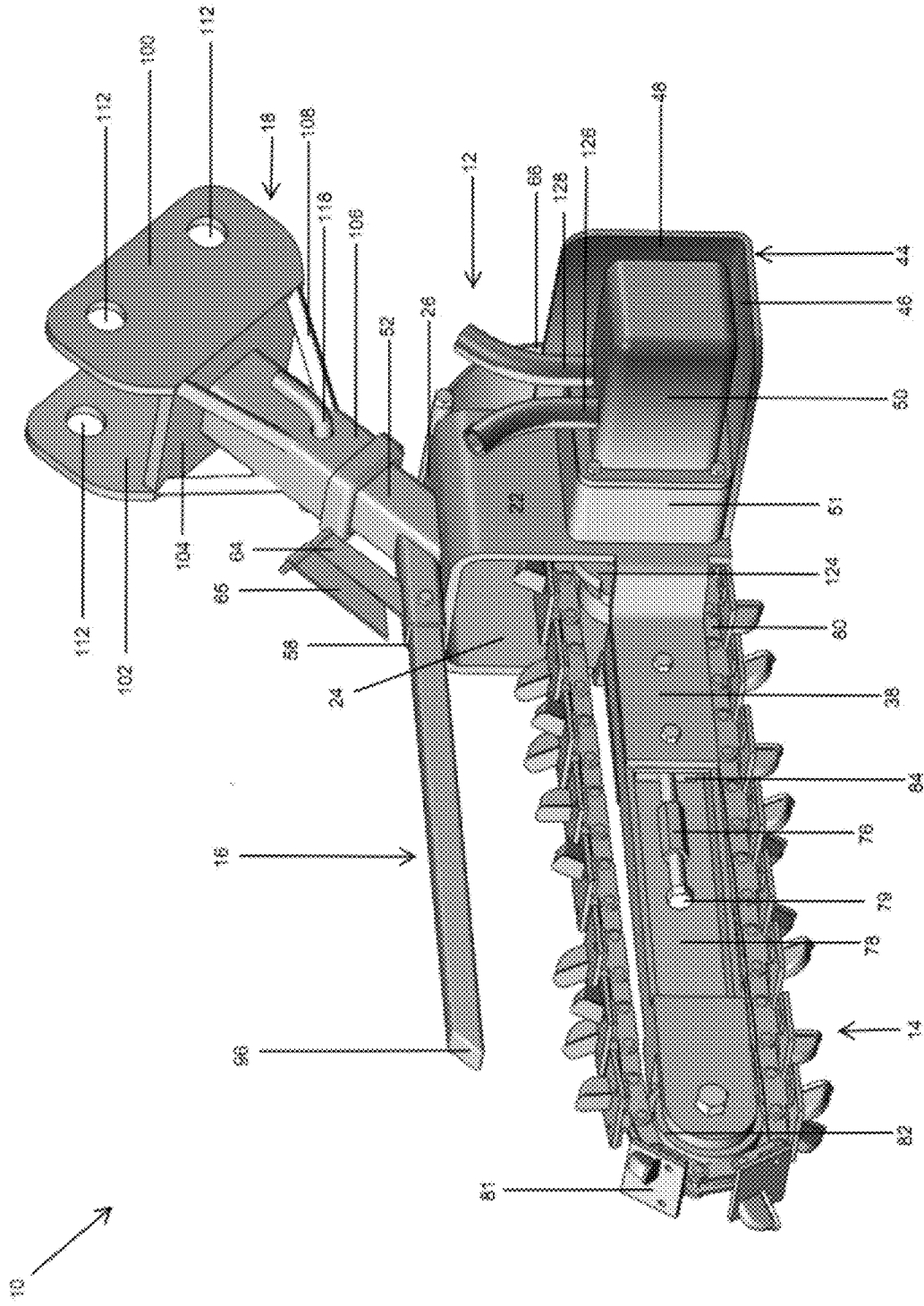

FIGURE 1

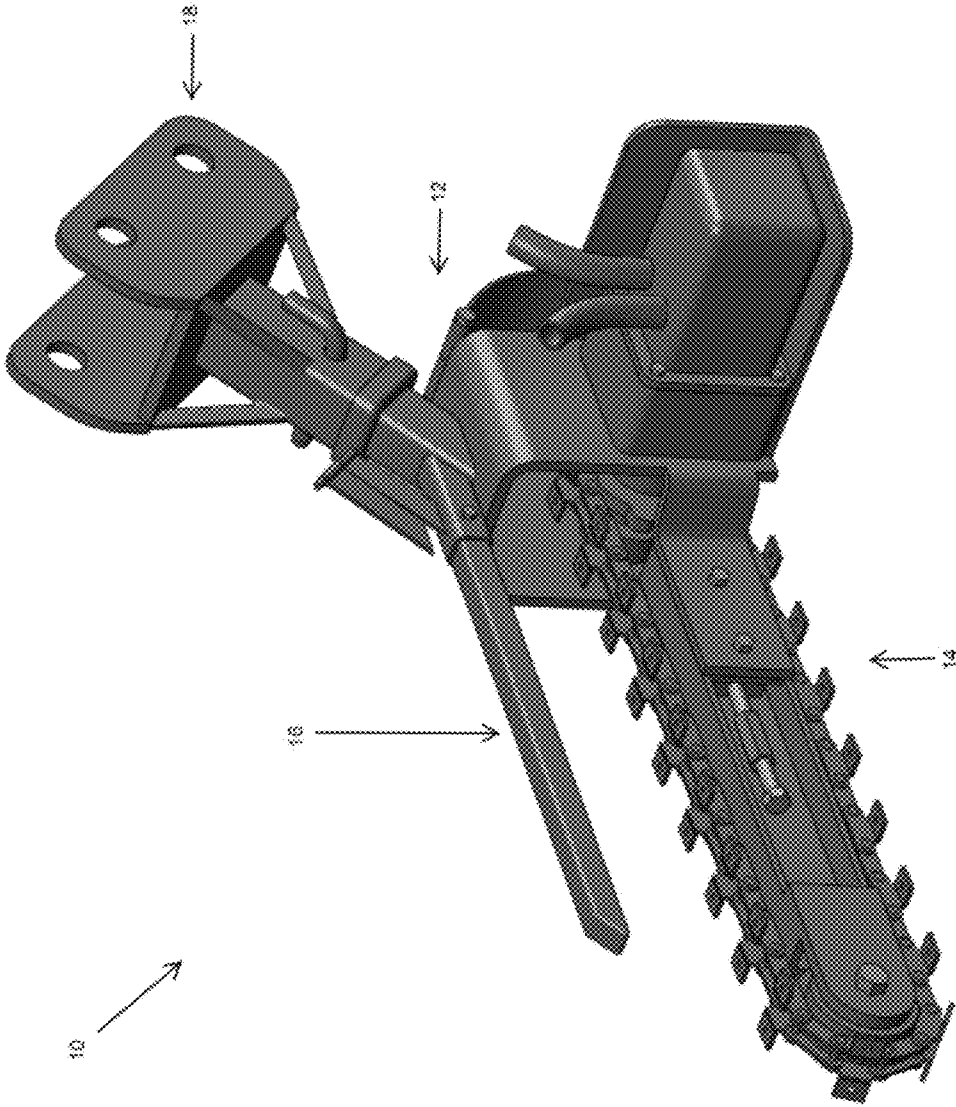

FIGURE 2

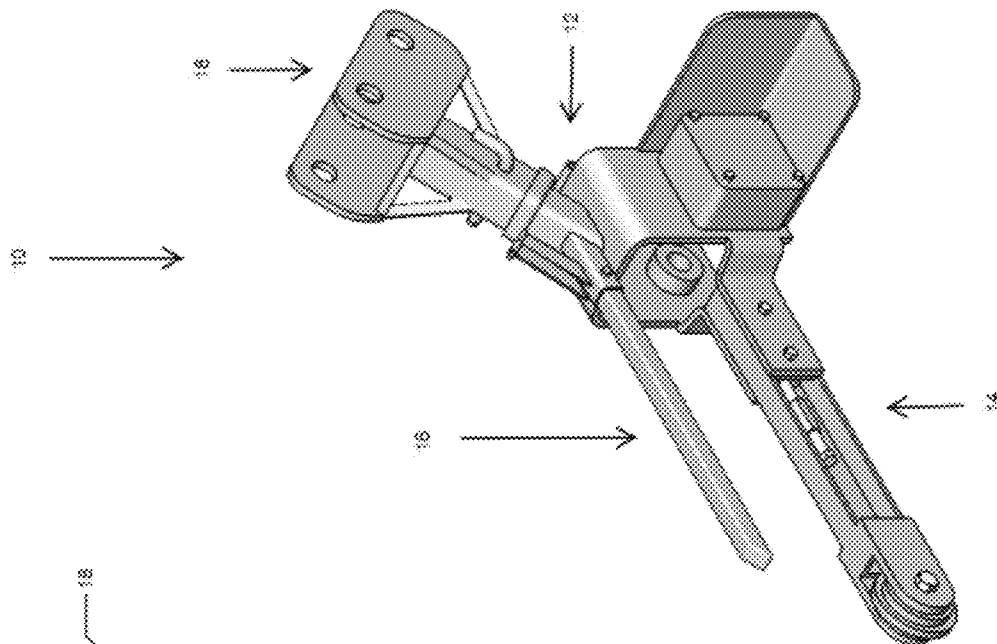

FIGURE 3A

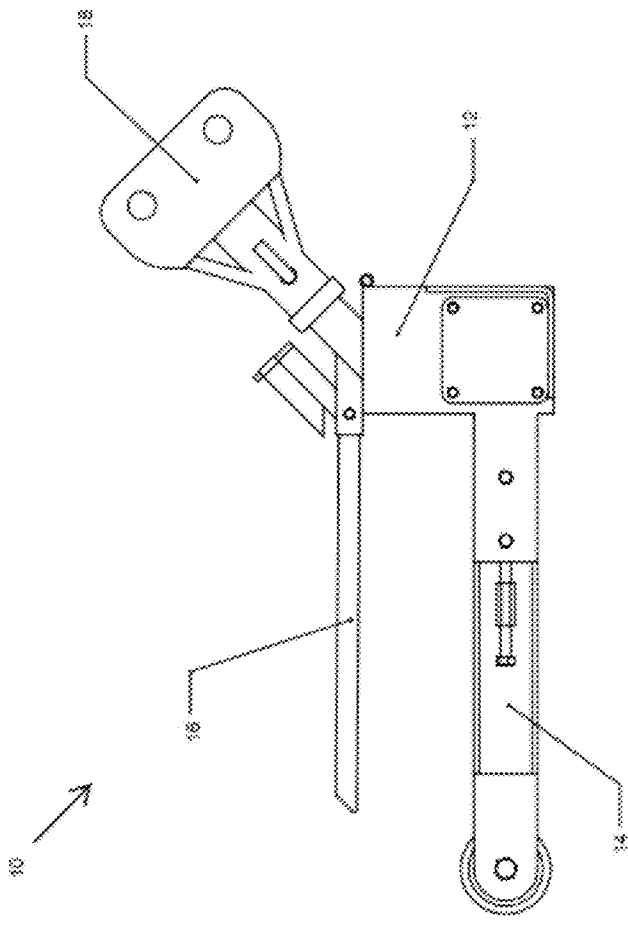
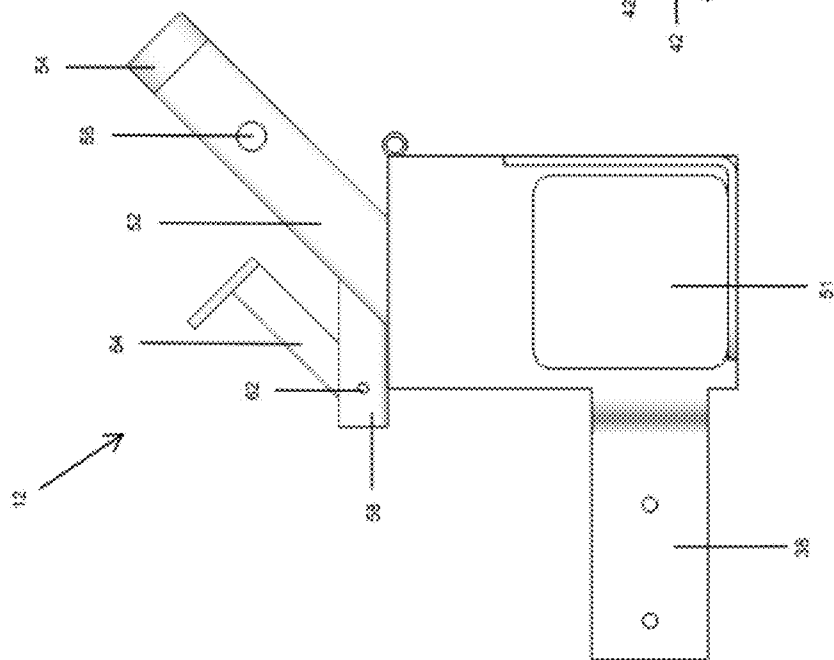
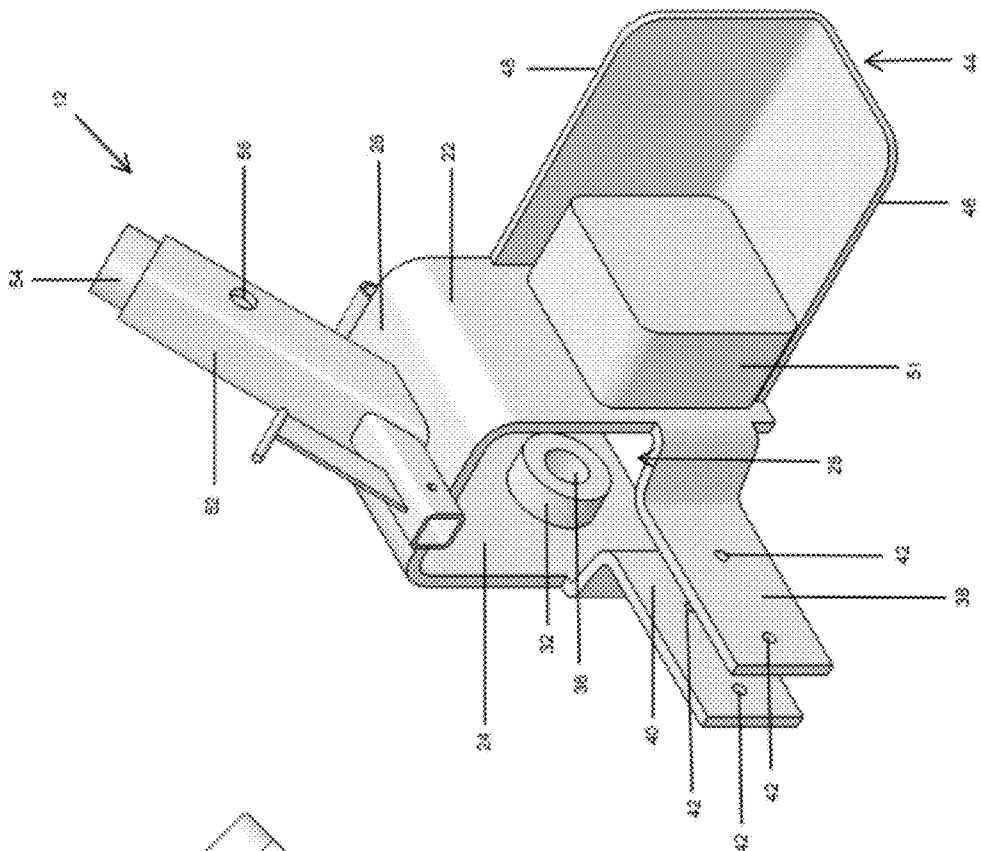

FIGURE 3B



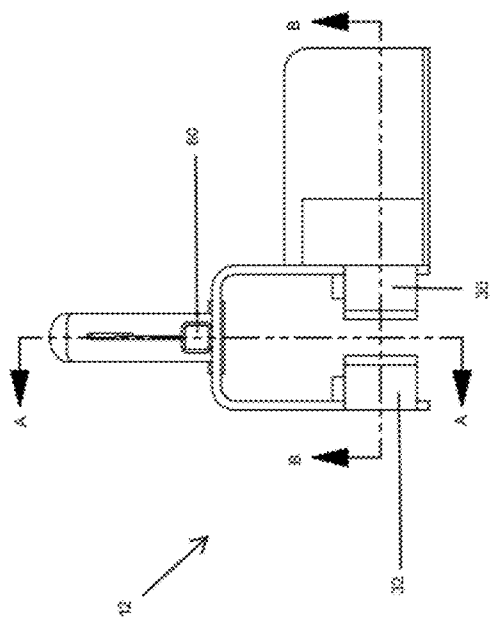

FIGURE 4C

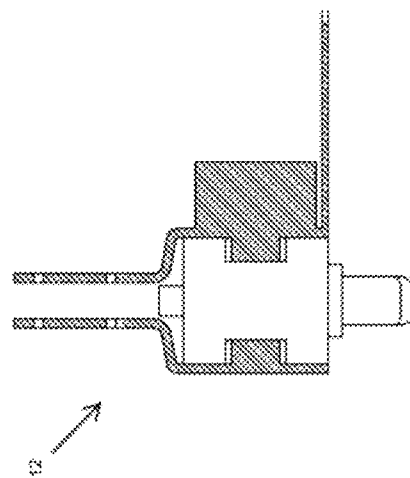

FIGURE 4E

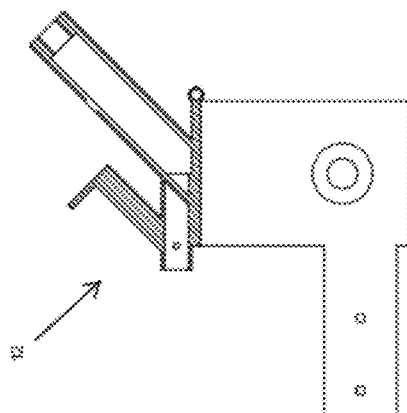
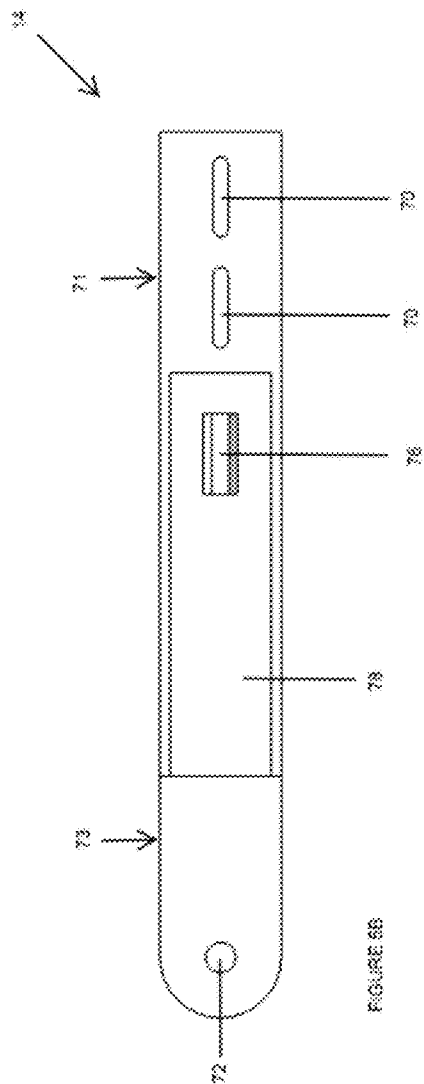
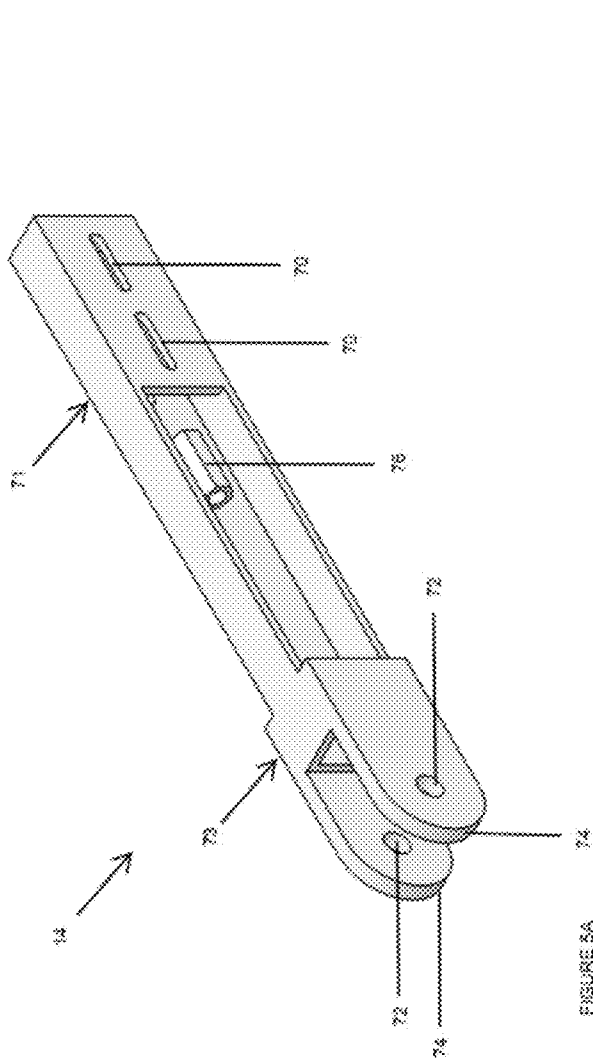

FIGURE 4D



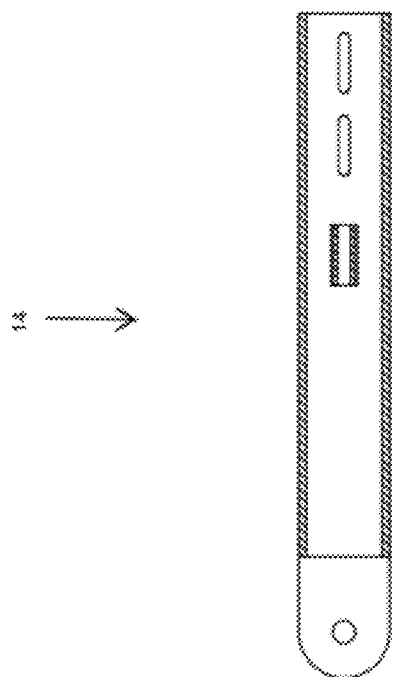

FIGURE 5E

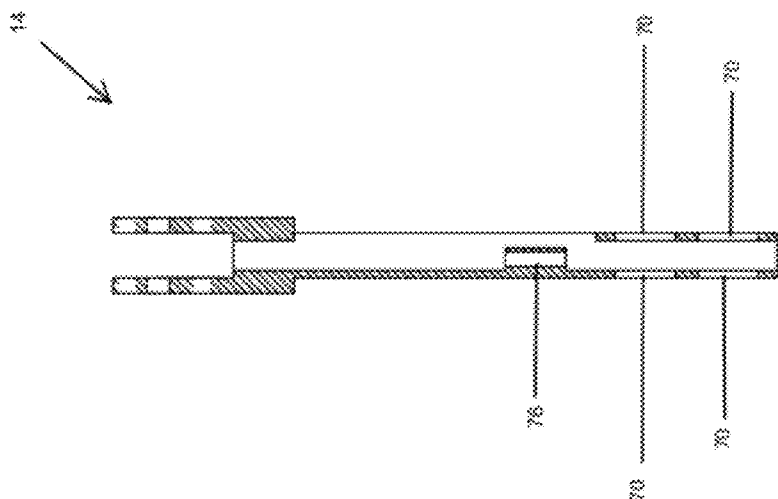

FIGURE 5D

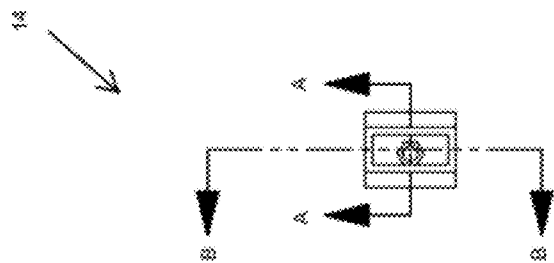

FIGURE 5C

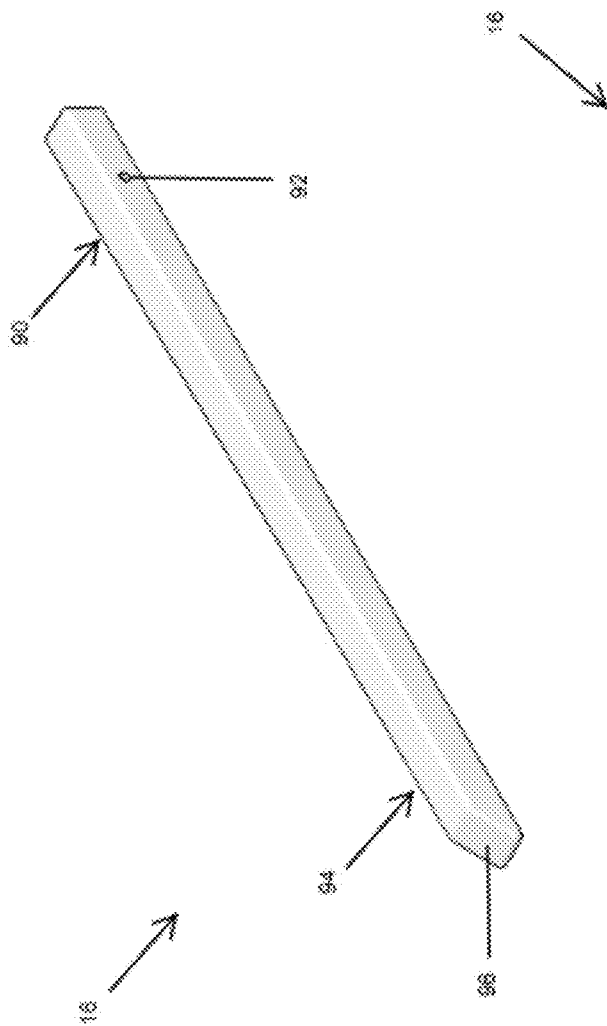

FIGURE 8A

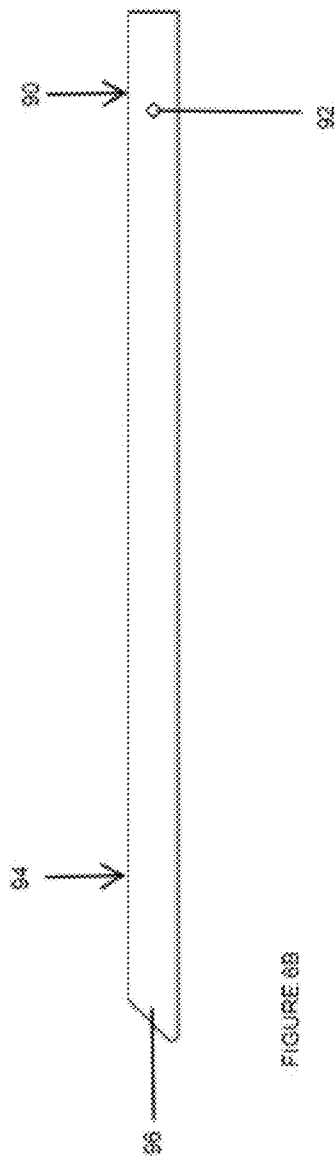

FIGURE 8B

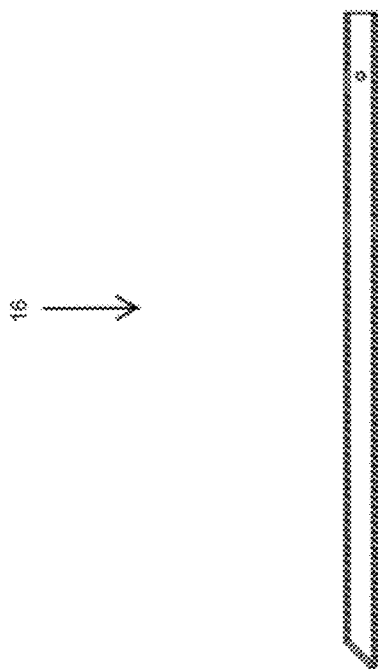

FIGURE 6E



FIGURE 6D

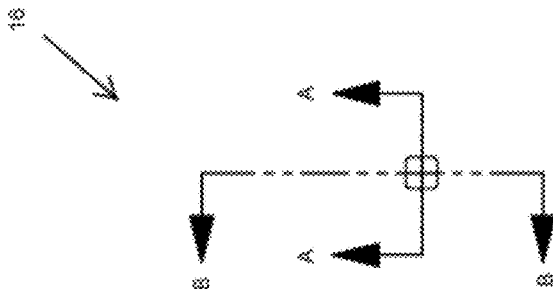

FIGURE 6C

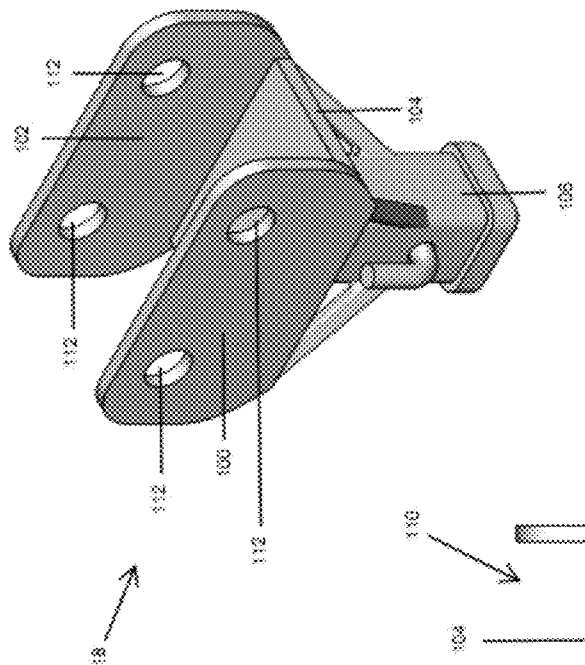

FIGURE 74

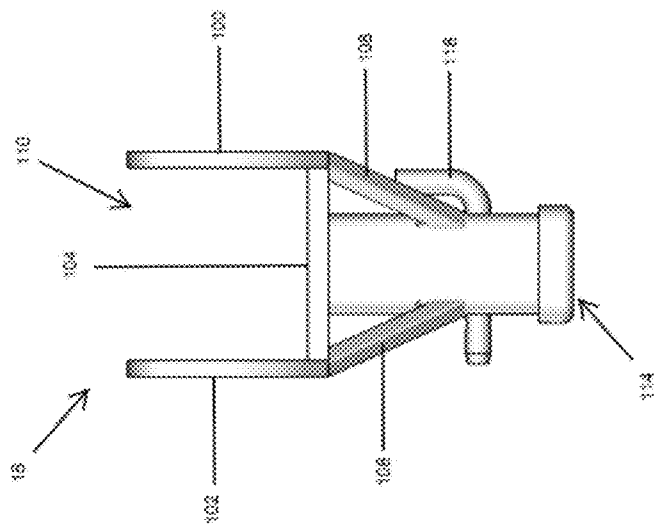

FIGURE 7B

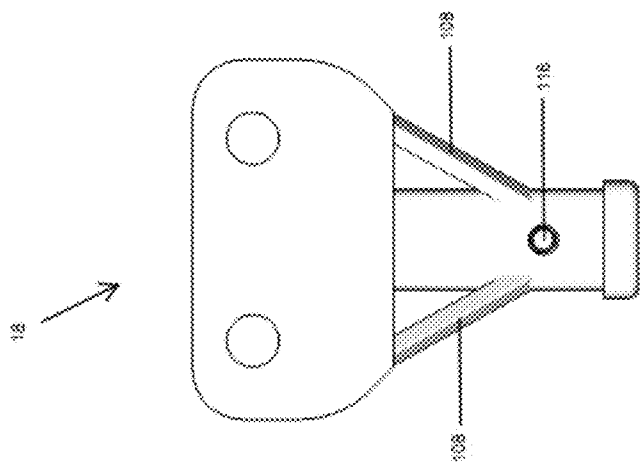
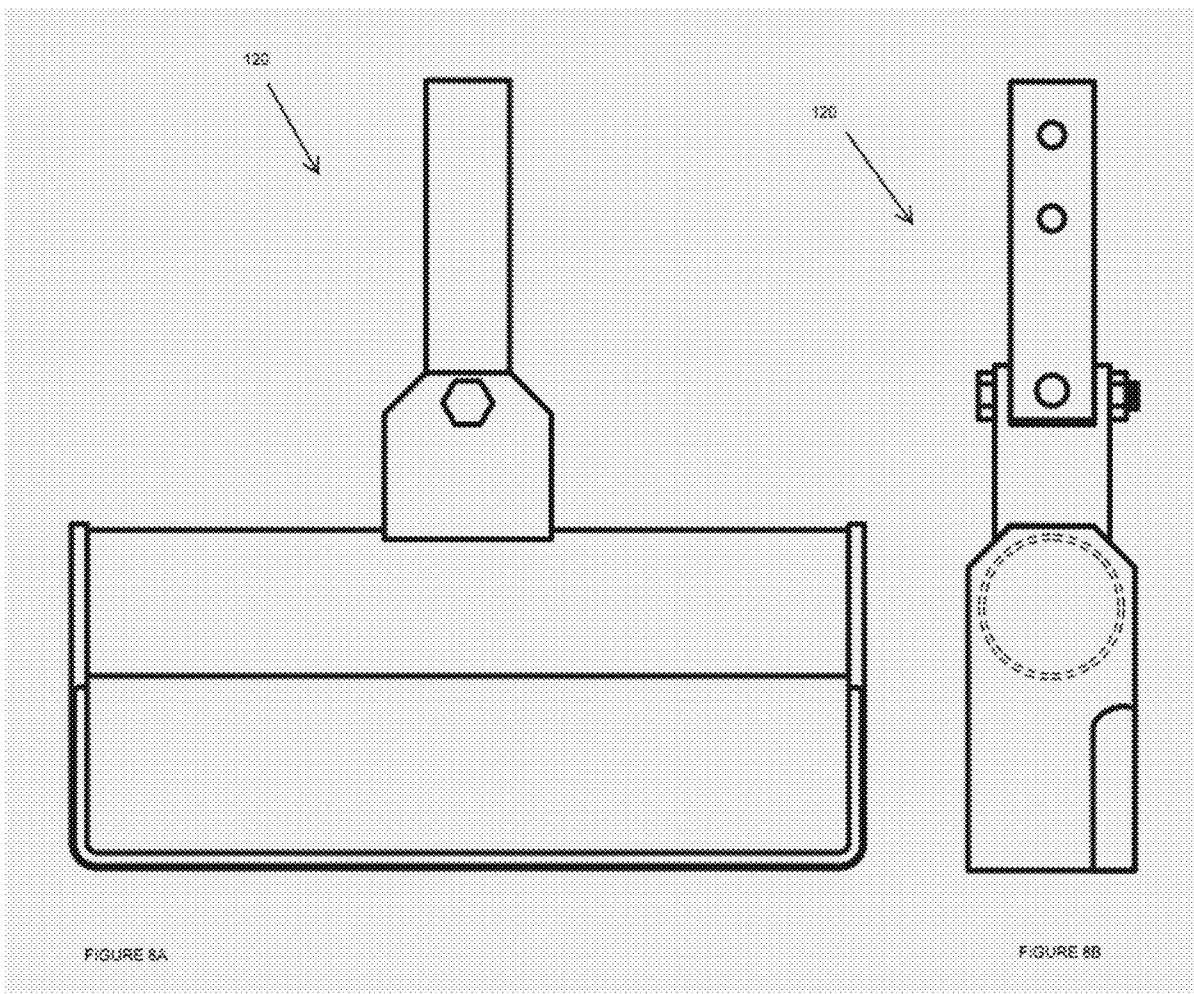

FIGURE 7C



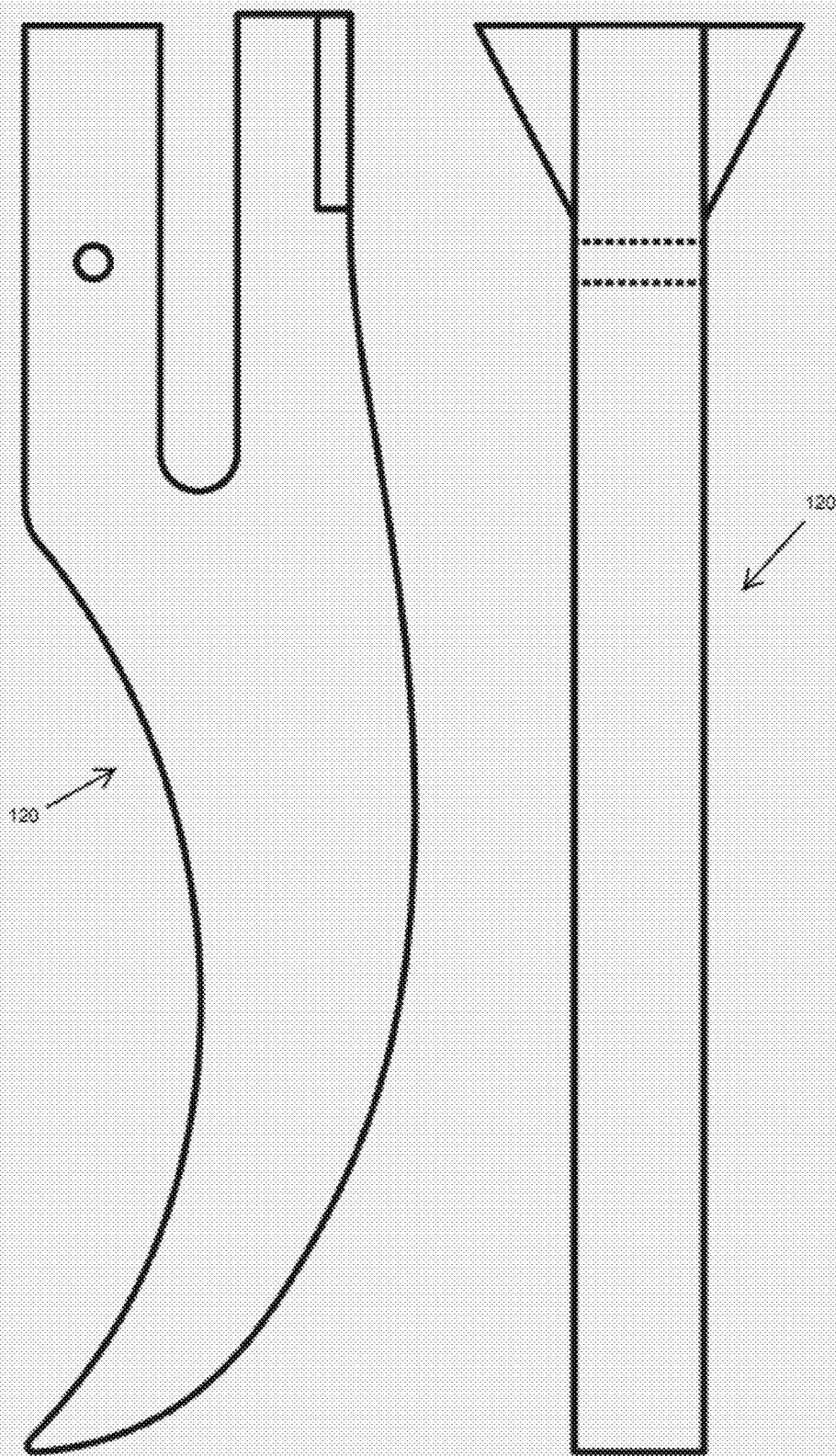
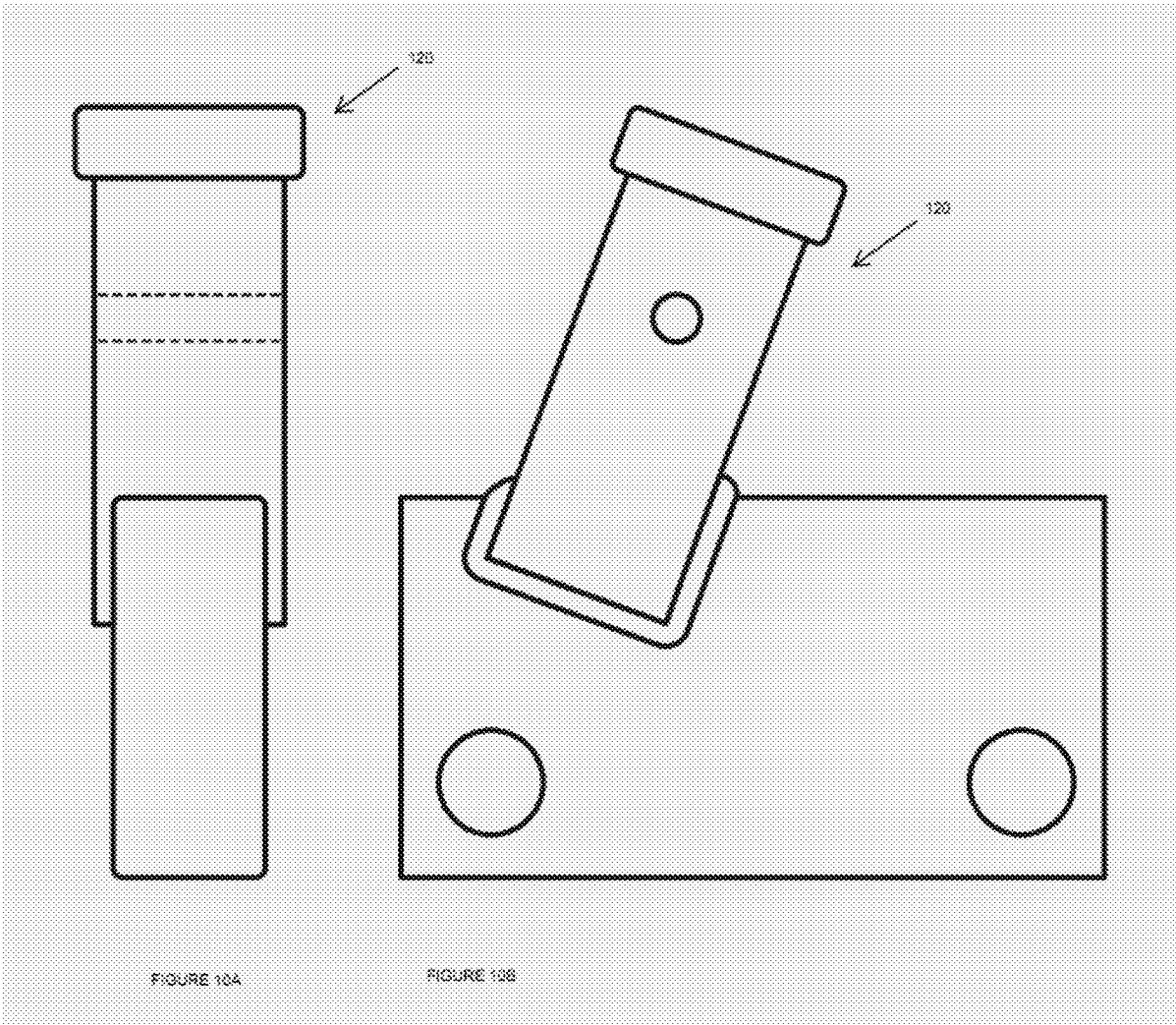
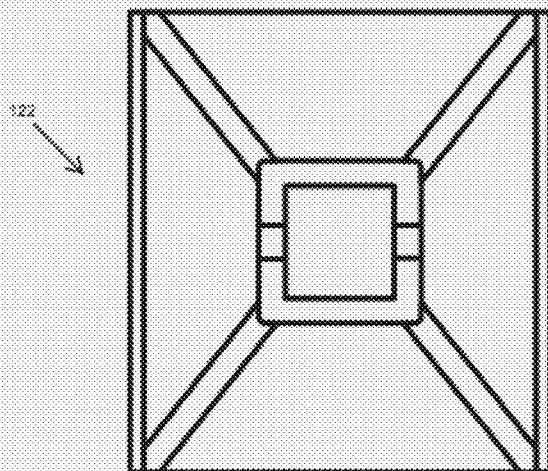
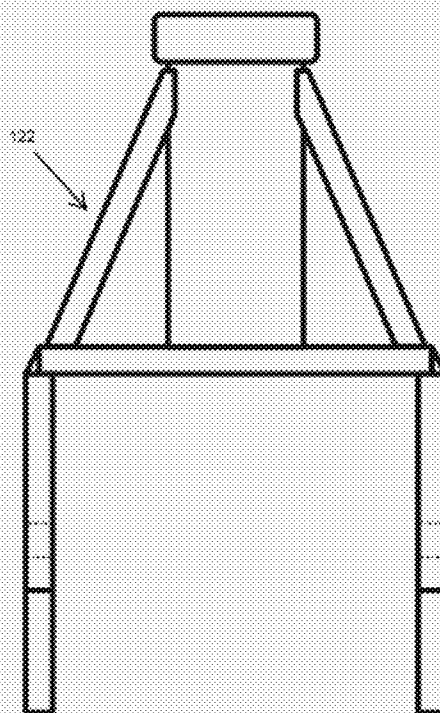
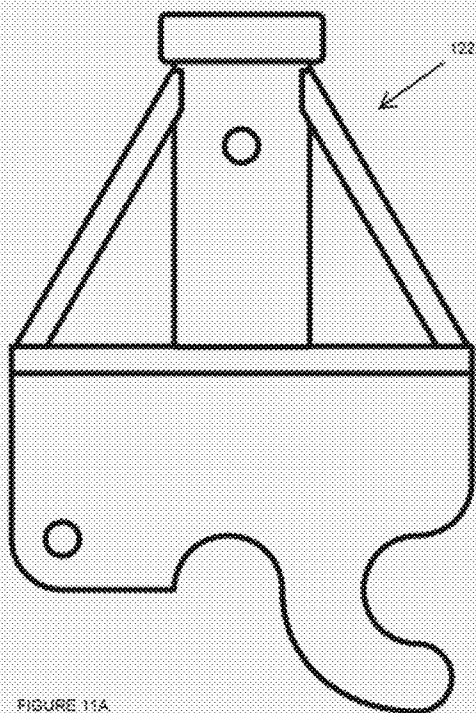

FIGURE 8A

FIGURE 9B





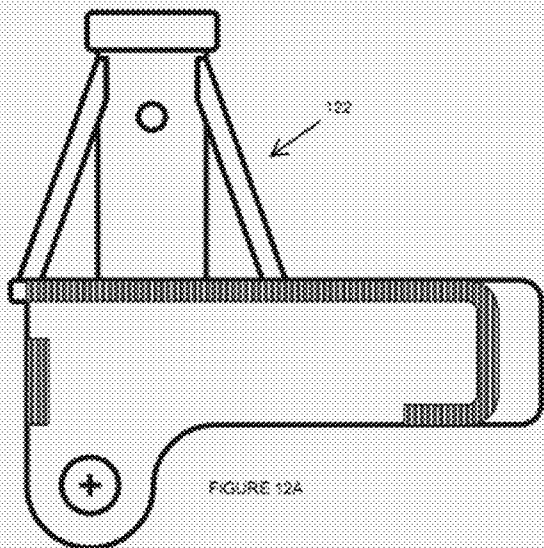

FIGURE 12A

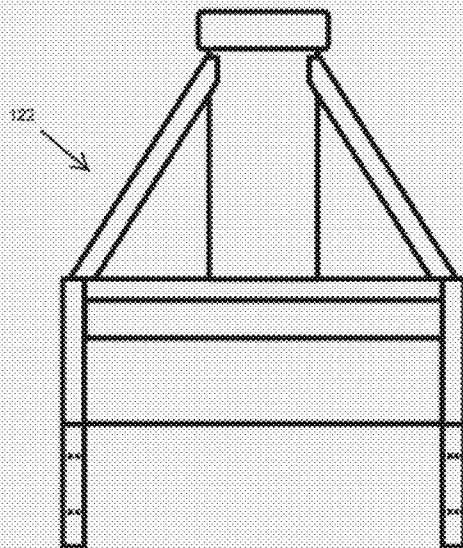

FIGURE 12B

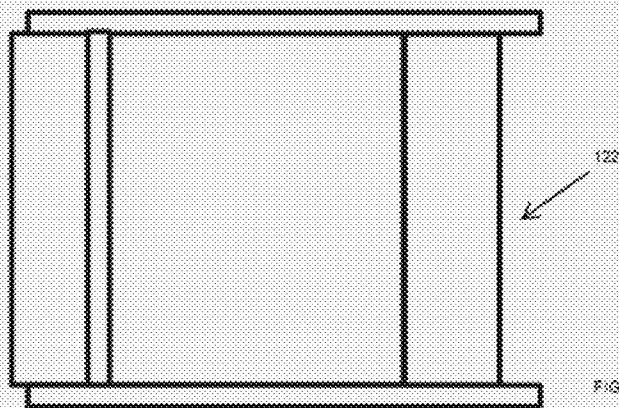

FIGURE 12C

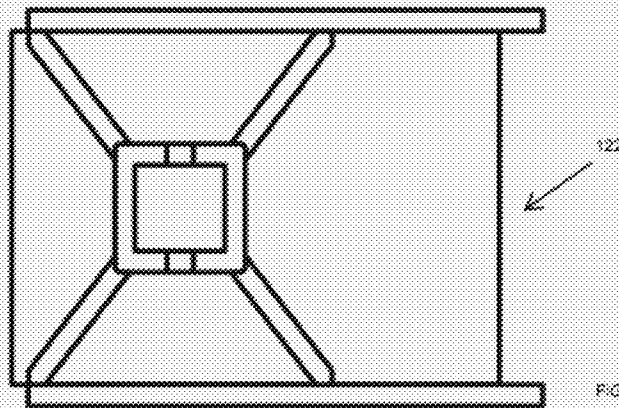

FIGURE 12D

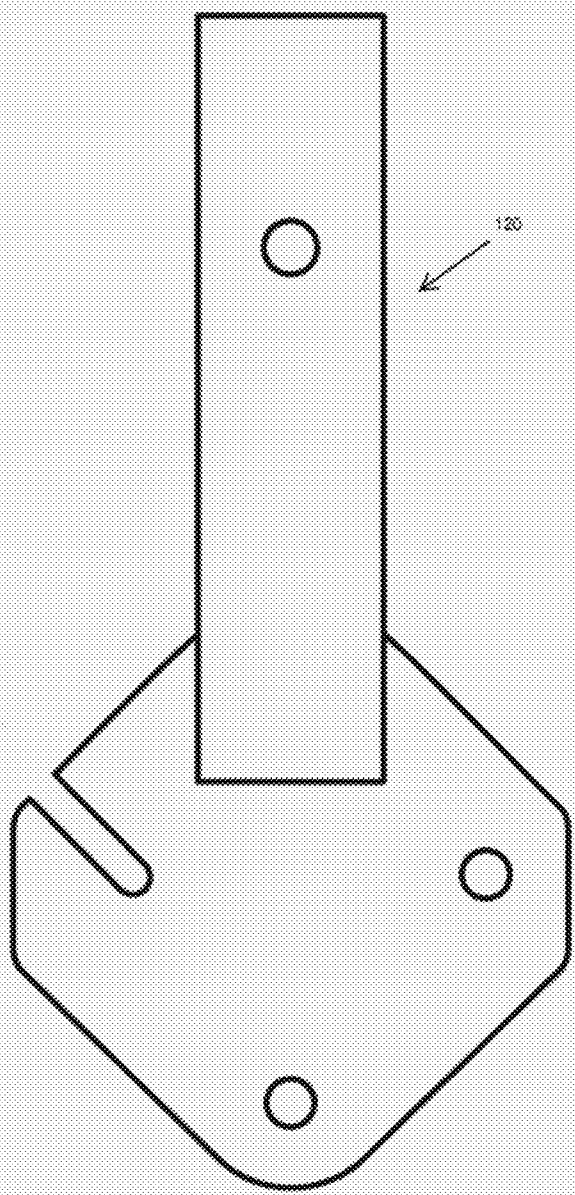

FIGURE 13A

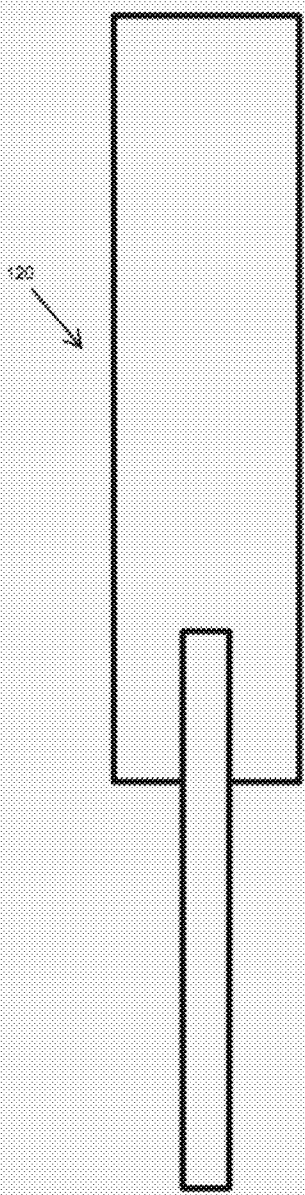

FIGURE 13B

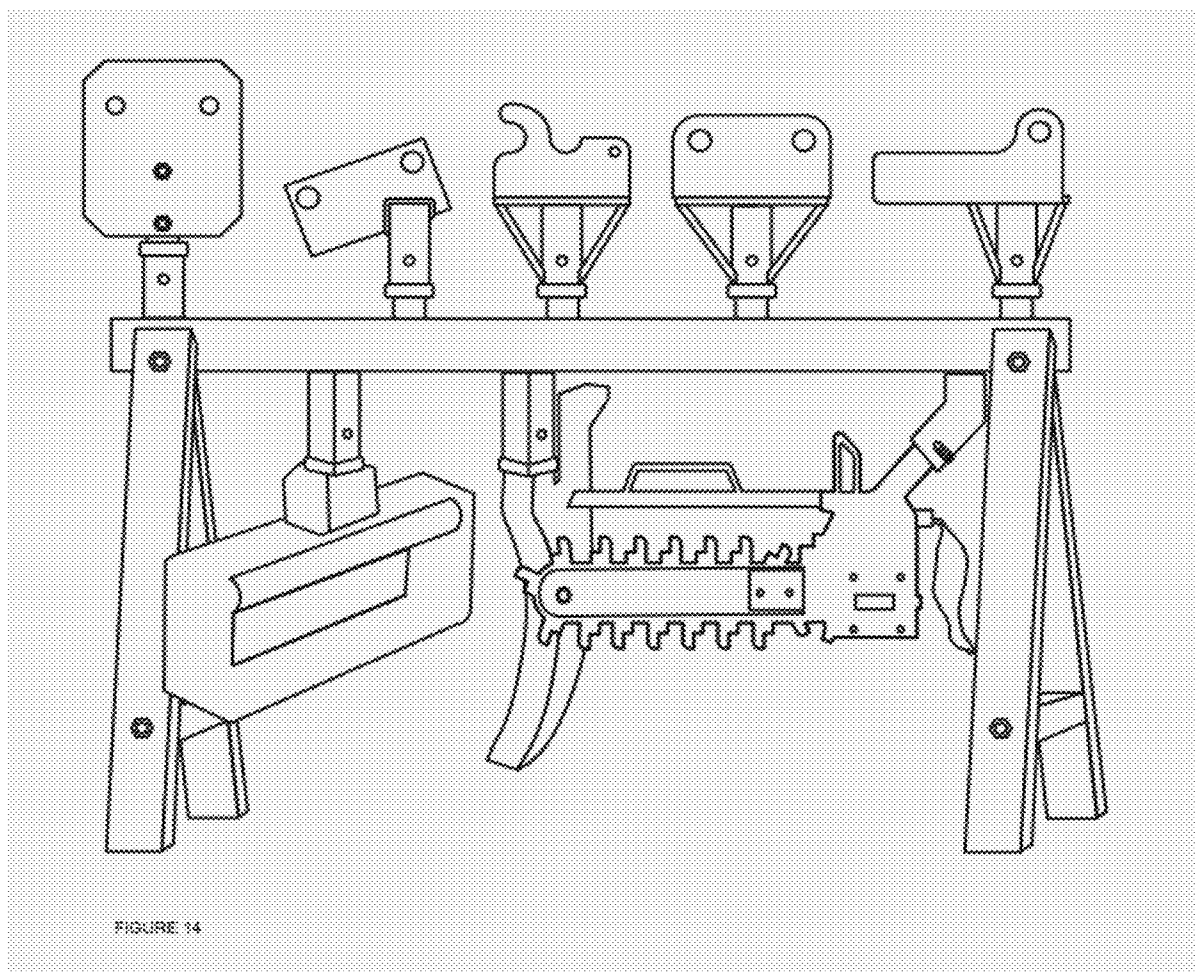

FIGURE 14

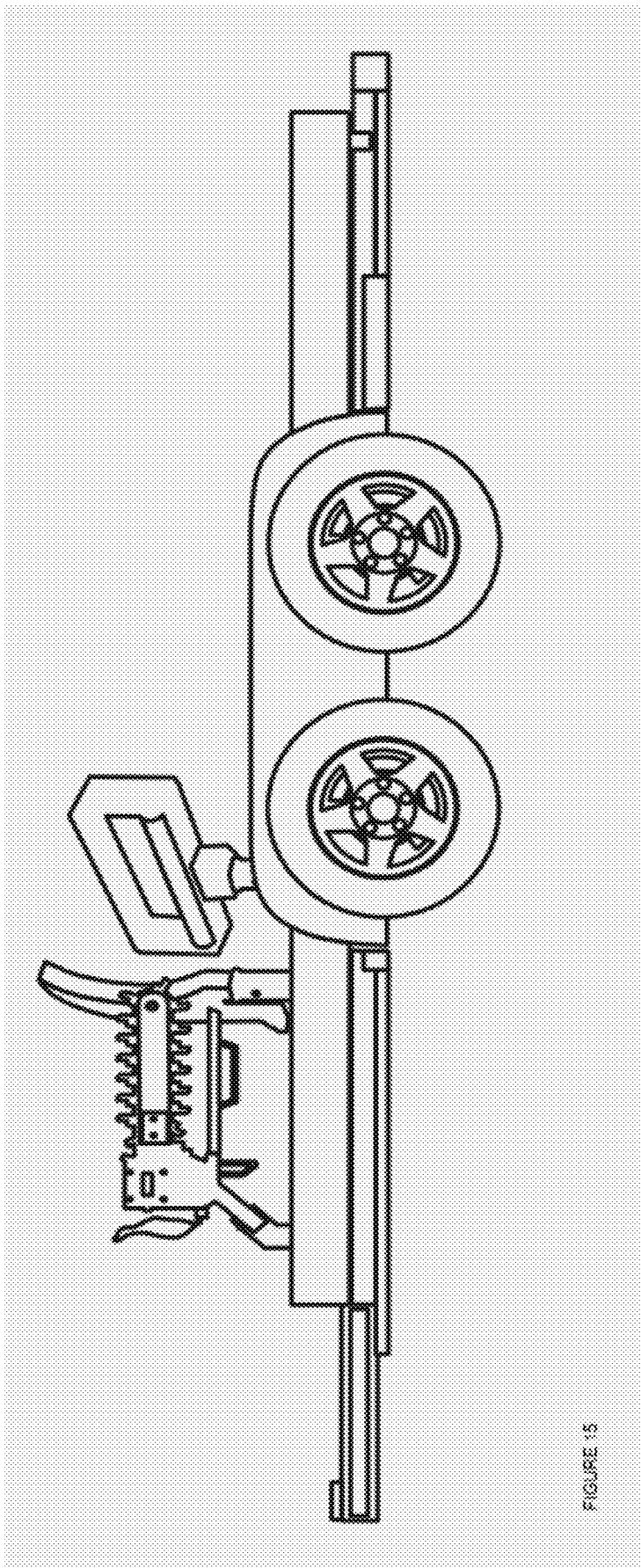

FIGURE 15

TRENCHER ASSEMBLY AND ASSOCIATED ACCESSORIES

CROSS-REFERENCE TO RELATED APPLICATIONS

[0001] This application claims the benefit of U.S. Provisional Application Ser. No. 61/441,333, filed Feb. 10, 2011, entitled “TRENCHER ASSEMBLY AND ASSOCIATED ACCESSORIES,” which is hereby incorporated herein by reference in its entirety, including all references cited therein.

BACKGROUND OF THE INVENTION

[0002] 1. Field of the Invention

[0003] The present invention relates in general to a trencher assembly and, more particularly, to a trencher assembly for use in association with excavators, including, but not limited to, compact and sub-compact excavators.

[0004] 2. Background Art

[0005] Trencher assemblies have been known in the art for years, and are the subject of numerous patents, including: U.S. Pat. No. 3,787,989 entitled “TRENCHER WITH ADJUSTABLE STABILIZER BAR,” U.S. Pat. No. 4,103,441 entitled “TRENCHER WITH OFFSET DRIVE WHEELS,” U.S. Pat. No. 4,326,347 entitled “NARROW DITCH TRENCHER,” U.S. Pat. No. 4,483,084 entitled “TRENCHER,” and U.S. Pat. No. 6,658,768 entitled “TRENCHER”—all of which are hereby incorporated herein by reference in their entirety including the references cited therein.

[0006] U.S. Pat. No. 3,787,989 appears to disclose a trencher of the endless bucket or rotary wheel type, which has an adjustable crumbing stabilizer. The stabilizer is adjusted vertically by means of a chain and sprocket arrangement, the sprocket being fixed to the digger frame and the chain being fixed at both ends to the stabilizer. A hydraulic braking device is used to hold the stabilizer in the adjusted position.

[0007] U.S. Pat. No. 4,103,441 appears to disclose a trencher for digging a trench in the ground, which includes ground wheels and a power drive unit and a trencher boom with a digging chain. The trencher boom is pivotally supported about an axis in the trencher, and the ground wheels are driven traction wheels which are located in axially-offset positions to give optimum support for the trencher and resist the reactive forces of the operation of the trencher chain on the remainder of the trencher, all so that the traction wheels remain firmly on the ground and are not lifted off the ground through the reactive forces created by the trencher boom and its digging chain. A caster wheel is included in the ground wheels and is mounted to be free to caster and to alternatively be restricted relative to the remainder of the trencher for guiding the trencher along a desired line of mobilization.

[0008] U.S. Pat. No. 4,326,347 appears to disclose a trencher for excavating narrow channels in soil which comprises a power driven wheel rotating about a transverse, horizontal axis and a plurality of buckets disposed about its periphery. The wheel includes a pair of circular gear racks disposed inwardly from its periphery and symmetrically about the vertical midplane of the wheel. A pair of pinions, engaging the pair of racks, symmetrically applies driving energy to the wheel. Each of the buckets comprise an arcuate cutter face and undercut, arcuate, longitudinal body portion which is secured to the wheel by a flat spoke extending radially outwardly from the vertical midplane of the wheel. The trencher

also includes two pairs of arms disposed on opposite sides of the wheel and bucket spokes. As the wheel and buckets rotate, soil is engaged, lifted above ground level and emptied from the buckets by the pairs of arms. Trenches for plastic drain pipe, for example, as deep as six feet and no wider than one foot may be dug by the trencher of the instant invention at speeds as great as forty feet per minute.

[0009] U.S. Pat. No. 4,483,084 appears to disclose a trencher machine for attachment to a tractor movably mounted hydraulically for up and down movement relative thereto, boom means for adjusting the depth of the cut in the soil, boom means pivotally mounted on a support means including cutting means thereon.

[0010] U.S. Pat. No. 6,658,768 appears to disclose a trencher, which includes a wheeled carriage that has a steering mechanism and a digging chain which operates along an upright path. The trencher includes an upright boom structure that is mounted to the carriage and a digging chain support frame that can be raised and lowered relative to the trencher carriage along an upright path. The digging chain is mounted to the digging chain support frame by a powered sprocket wheel and a freely turning pulley wheel. The sprocket wheel and the pulley wheel are positioned so that the digging chain describes an upright path. The path described by the digging chain is sufficiently upright so that the trencher can excavate a curved trench without the digging chain interfering with the walls of the trench to a degree that is sufficient to impede the operation of the trencher.

[0011] While the above-identified patents do appear to disclose trenchers, their configurations remain non-desirous and/or problematic inasmuch as, among other things, none of the above-identified trenchers appear to be configured to releasable adaptation to a compact and/or sub-compact excavator—among other things.

[0012] It is therefore an object of the present invention to provide a trencher assembly, which, among other things, remedies the aforementioned detriments and/or complications associated with the use of the above-identified, conventional trenchers.

[0013] It is also an object of the present invention to provide a plurality of accessory items which are securable to the brackets disclosed herein.

[0014] These and other objects of the present invention will become apparent in light of the present specification, claims, and drawings.

SUMMARY OF THE INVENTION

[0015] The present invention is directed to a trencher assembly for use in association with an excavator, comprising: (a) a body, wherein the body is configured for releasable securement with a boom, a crumber bar, and a bracket; (b) wherein the boom is releasably secured to the body, and further wherein the boom comprises an endless chain having a plurality of displaceable teeth; (c) wherein the crumber bar is releasably secured to the body, and further wherein the crumber bar is positioned above the boom; and (d) wherein the bracket is releasably secured to the body, and further wherein the bracket is adapted for releasable securement to the excavator, the tractor, and the like.

[0016] In a preferred embodiment of the present invention, the body comprises a first side wall, a second side wall, and a top wall which collectively form a drive assembly containment region.

[0017] In another preferred embodiment of the present invention, the body comprises a guard plate for shielding a hydraulic motor during operation of the trencher assembly.

[0018] In yet another preferred embodiment of the present invention, the top wall of the body is associated with a spray guard for limiting displacement of debris during operation of the trencher assembly.

[0019] In another aspect of the present invention, the housing comprises a crumber bar mounting bracket having a flopper plate positioned on a top wall of the same.

[0020] In a preferred embodiment of the present invention, the boom comprises a tensioner bolt sleeve positioned on a sidewall of the same, as well as a tensioner bolt access aperture.

[0021] In another preferred embodiment of the present invention, the crumber bar comprises an inwardly angled tip which extends from a bottom wall to a top wall of the crumber bar.

[0022] In yet another preferred embodiment of the present invention, the bracket comprises a first side wall, a second side wall, and a bottom wall which collectively form a substantially U-shaped containment region adapted for receipt of at least a portion of a boom of the excavator, the tractor, and the like. The bracket also preferably comprises a connecting sleeve having a pair of aligned apertures for receipt of a securement member. Moreover, the bracket preferably comprises a plurality of support members which are secured to a connecting sleeve and a bottom wall of the bracket.

[0023] The present invention is also directed to a trencher assembly for use in association with an excavator, consisting of: (a) a body, wherein the body is configured for releasable securement with a boom, a crumber bar, and a bracket; (b) wherein the boom is releasably secured to the body, and further wherein the boom comprises an endless chain having a plurality of displaceable teeth; (c) wherein the crumber bar is releasably secured to the body, and further wherein the crumber bar is positioned above the boom; and (d) wherein the bracket is releasably secured to the body, and further wherein the bracket is adapted for releasable securement to the excavator, the tractor, and the like.

[0024] The present invention is further directed to a trencher assembly for use in combination with a primary boom of an excavator, the combination comprising: (a) an excavator, a tractor, and the like having a primary boom; (b) a trencher assembly comprising a body, wherein the body is configured for releasable securement with a secondary boom, a crumber bar, and a bracket; (c) wherein the secondary boom is releasably secured to the body, and further wherein the secondary boom comprises an endless chain having a plurality of displaceable teeth; (d) wherein the crumber bar is releasably secured to the body, and further wherein the crumber bar is positioned above the secondary boom; and (e) wherein the bracket is releasably secured to the body, and further wherein the bracket is secured to the primary boom of the excavator.

[0025] The present invention is additionally directed to a plurality of accessory items which are releasably securable to the brackets disclosed herein.

BRIEF DESCRIPTION OF THE DRAWINGS

[0026] Certain embodiments of the present invention are illustrated by the accompanying figures. It will be understood that the figures are not necessarily to scale and that details not necessary for an understanding of the invention or that render other details difficult to perceive may be omitted. It will be

further understood that the invention is not necessarily limited to the particular embodiments illustrated herein.

[0027] The invention will now be described with reference to the drawings wherein:

[0028] FIG. 1 of the drawings is a perspective view of a trencher assembly manufactured in accordance with the present invention;

[0029] FIG. 2 of the drawings is a perspective view of a trencher assembly manufactured in accordance with the present invention showing an endless chain without bolt-on teeth;

[0030] FIG. 3A of the drawings is perspective view of a trencher assembly manufactured in accordance with the present invention showing a body, a boom, a crumber bar, and a bracket;

[0031] FIG. 3B of the drawings is side elevation view of a trencher assembly manufactured in accordance with the present invention showing a body, a boom, a crumber bar, and a bracket;

[0032] FIG. 4A of the drawings is perspective view of a body of a trencher assembly manufactured in accordance with the present invention;

[0033] FIG. 4B of the drawings is a side elevation view of a body of a trencher assembly manufactured in accordance with the present invention;

[0034] FIG. 4C of the drawings is a front view of a body of a trencher assembly manufactured in accordance with the present invention;

[0035] FIG. 4D of the drawings is a cross-section view of a body of a trencher assembly manufactured in accordance with the present invention taken along line A-A of FIG. 4C;

[0036] FIG. 4E of the drawings is a bottom view of a body of a trencher assembly manufactured in accordance with the present invention taken along line B-B of FIG. 4C;

[0037] FIG. 5A of the drawings is perspective view of a boom of a trencher assembly manufactured in accordance with the present invention;

[0038] FIG. 5B of the drawings is a side elevation view of a boom of a trencher assembly manufactured in accordance with the present invention;

[0039] FIG. 5C of the drawings is a front view of a boom of a trencher assembly manufactured in accordance with the present invention;

[0040] FIG. 5D of the drawings is a bottom view of a body of a trencher assembly manufactured in accordance with the present invention taken along line A-A of FIG. 5C;

[0041] FIG. 5E of the drawings is a cross-section view of a body of a trencher assembly manufactured in accordance with the present invention taken along line B-B of FIG. 5C;

[0042] FIG. 6A of the drawings is perspective view of a crumber bar of a trencher assembly manufactured in accordance with the present invention;

[0043] FIG. 6B of the drawings is a side elevation view of a crumber bar of a trencher assembly manufactured in accordance with the present invention;

[0044] FIG. 6C of the drawings is a front view of a crumber bar of a trencher assembly manufactured in accordance with the present invention;

[0045] FIG. 6D of the drawings is a bottom view of a crumber bar of a trencher assembly manufactured in accordance with the present invention taken along line A-A of FIG. 6C;

[0046] FIG. 6E of the drawings is a cross-section view of a crumber bar of a trencher assembly manufactured in accordance with the present invention taken along line B-B of FIG. 6C;

[0047] FIG. 7A of the drawings is perspective view of a bracket of a trencher assembly manufactured in accordance with the present invention;

[0048] FIG. 7B of the drawings is an end view of a crumber bar of a trencher assembly manufactured in accordance with the present invention;

[0049] FIG. 7C of the drawings is a side elevation view of a crumber bar of a trencher assembly manufactured in accordance with the present invention;

[0050] FIG. 8A of the drawings is a front view of a sod cutter manufactured in accordance with the present invention;

[0051] FIG. 8B of the drawings is an end view of a sod cutter manufactured in accordance with the present invention;

[0052] FIG. 9A of the drawings is a side elevation view of a ripper tooth manufactured in accordance with the present invention;

[0053] FIG. 9B of the drawings is a top view of a ripper tooth manufactured in accordance with the present invention;

[0054] FIG. 10A of the drawings is a side elevation view of a vibratory plow and sod cutter adapter manufactured in accordance with the present invention;

[0055] FIG. 10B of the drawings is a front view of a vibratory plow and sod cutter adapter manufactured in accordance with the present invention;

[0056] FIG. 11A of the drawings is a side elevation view of an adaptor manufactured in accordance with the present invention;

[0057] FIG. 11B of the drawings is an end view of an adaptor manufactured in accordance with the present invention;

[0058] FIG. 11C of the drawings is a top view of an adapter manufactured in accordance with the present invention;

[0059] FIG. 12A of the drawings is a side elevation view of an adaptor manufactured in accordance with the present invention;

[0060] FIG. 12B of the drawings is an end view of an adaptor manufactured in accordance with the present invention;

[0061] FIG. 12C of the drawings is a bottom view of an adaptor manufactured in accordance with the present invention;

[0062] FIG. 12D of the drawings is a top view of an adapter manufactured in accordance with the present invention;

[0063] FIG. 13A of the drawings is a bottom view of an adapter manufactured in accordance with the present invention;

[0064] FIG. 13B of the drawings is a top view of an adapter manufactured in accordance with the present invention;

[0065] FIG. 14 of the drawings is a perspective view of a tool kit stand manufactured in accordance with the present invention; and

[0066] FIG. 15 of the drawings is a side elevation view of a trailer assembly manufactured in accordance with the present invention.

DETAILED DESCRIPTION OF THE INVENTION

[0067] While this invention is susceptible of embodiment in many different forms, there is shown in the drawings and described herein in detail several specific embodiments with the understanding that the present disclosure is to be consid-

ered as an exemplification of the principles of the invention and is not intended to limit the invention to the embodiments illustrated.

[0068] It will be understood that like or analogous elements and/or components, referred to herein, may be identified throughout the drawings with like reference characters. It will be further understood that FIGS. 1-15 are merely schematic representations of trencher assemblies and accessories. As such, some of the components have been distorted from their actual scale for pictorial clarity.

[0069] Referring now to the drawings and to FIGS. 1, 2, 3A, and 3B in particular, trencher assembly 10 is disclosed which generally comprises body 12, boom 14, crumber bar 16, and mounting bracket 18. As will be discussed in greater detail herein below the trencher assemblies of the present invention comprises several features and/or operational benefits, including, but not limited to: (1) the trencher assemblies attach quickly and easily to most excavators (approximately 13-30 hp, auxiliary flow approximately 7.5-15 gpm); (2) the trencher assemblies of the present invention are continuously variable and trench in-line or 90 degrees offset from the excavator; (3) the offset trenching allows for trenching above or below retaining walls or structures while the excavator is operated a safe distance away; (4) the trenchers dig up to approximately 20 feet deep by approximately 4 feet wide; (5) the trenchers are ideally suited for installation of irrigation pipe, electrical wire, plumbing drainage pipe, etcetera; (6) the trenchers are an excellent choice for small openings in hard packed soils; (7) the trenchers comprise heavy duty construction, and are yet lightweight; and (8) the trenchers essentially eliminate difficult and, often times, back-breaking work.

[0070] Referring now to FIGS. 1, 2, 3A, 3B, and 4A-4E, body 12 includes an inverted U-shaped housing defined by sidewalls 22 and 24, and top wall 26. Sidewalls 22 and 24 are spaced apart and generally parallel to each other to define drive assembly containment region 28 for containing a drive assembly which is discussed in greater detail herein below. Sidewalls 22 and 24 include female shaft receptacles 30 and 32, respectively, which each include apertures 34 (not shown) and 36, respectively. In accordance with the present invention, one or more of the female shaft receptacles preferably include a bearing, such as a self-aligning pillow block bearing, and the like.

[0071] A pair of mounting plates 38 and 40 emanate contiguously from sidewalls 22 and 24, respectively. Mounting plates 38 and 40 include aligned slots or apertures 42 for releasably securing boom 14 thereto with conventional threaded fasteners.

[0072] L-shaped guard plate 44 emanates contiguously from sidewall 22 of body 12 and includes bottom wall 46 and back wall 48. Guard plate 44 protects hydraulic motor 50 during storage and/or operation of trencher assembly 10. Hydraulic junction box 51 is positioned adjacent to sidewall 22 and within the protective boundaries of guard plate 44.

[0073] Mounting bracket member 52 is positioned on top wall 26 of body 12 and optionally includes sleeve 54 and aperture 56. Mounting bracket member 52 is preferably fixedly attached (e.g., welded) to top wall 26 of body member 12.

[0074] Crumber bar mounting member 58 is positioned on top wall 26 of body 12 and includes sleeve 60, aperture 62, and L-shaped plate 64, and flopper plate 65. Crumber bar mounting member 58 is preferably fixedly welded to top wall 26 of body 12.

[0075] Body **12** also includes spray guard plate **66** which limits displacement of debris during operation of trencher assembly **10**.

[0076] Referring now to FIGS. **1**, **2**, **3A**, **3B**, and **5A-5E**, boom **14** generally comprises a tubular, rectangular housing which includes first end **71** having four aligned tensioner slots **70**, and second end **73** having two aligned idler wheel slots **72** positioned within rounded end plates **74**. Tensioner bolt sleeve **76** is mounted to an inner wall of boom **14** and is positioned between first end **71** and second end **73**. Boom **14** also includes tension bolt access aperture **78** which allows a user to adjust tensioner bolt **79**, and, in turn, the tightness of endless chain **80** via cooperation with tensioner block **84**.

[0077] First end **71** of boom **14** is secured to mounting plates **38** and **40** of body **12** via conventional threaded fasteners. Idler wheel (e.g., nose end roller bearing) **82** is secured to second end **73** of boom **14** via conventional threaded fasteners. It will be understood that idler wheel **82** is readily interchangeable with an idler sprocket.

[0078] Referring now to FIGS. **1**, **2**, **3A**, **3B**, and **6A-6E**, crumber bar **16** generally comprises a tubular, rectangular and/or square housing which includes first end **90** having two aligned slots **92** and second end **94** having angled tip **96**. First end **90** of crumber bar **16** is secured to crumber bar mounting member **58** of body **12** via conventional threaded fasteners. Although not shown, crumber bar **16** may optionally comprise a handle. It will be understood that crumber bar **16** may optionally include a curved plate as is shown in U.S. Pat. No. 4,483,084—which is hereby incorporated herein by reference in its entirety. It will be understood that crumber bar **16** serves as, among other things, a guard to prevent injury.

[0079] Referring now to FIGS. **1**, **2**, **3A**, **3B**, and **7A-7C**, bracket **18** includes sidewalls **100** and **102**, bottom wall **104**, connecting sleeve **106**, and support members **108**. Sidewalls **100** and **102** are spaced apart and generally parallel to each other, and in cooperation with bottom wall **104** define containment region **110** for containing a boom attachment from an excavator, tractor, and/or the like. Sidewalls **100** and **102** and bottom wall **104** are preferably, generally U-shaped. Sidewalls **100** and **102** include apertures **112**, for receiving fasteners associated with the boom of an excavator. Connecting sleeve **106** is positioned below bottom wall **104** and comprises a generally rectangular, tubular sleeve having mounting aperture **114** and aligned securing apertures **116**. Connecting sleeve **106** mounts onto bracket mounting member **52** of body **12** via mounting aperture **114**, and is secured to the same via fastener **118** which releasably engages both aperture **56** of body **12** and aperture **116** of bracket **18**. Bracket **18** also includes support members **108** which are secured to bottom wall **104** and connecting sleeve **116**, proximate the midpoint thereof.

[0080] In accordance with the present invention, endless chain **80**, and, in turn, bolt-on teeth **81** are displaced by the drive sub-assembly of trencher assembly **10**. The drive sub-assembly comprises hydraulic motor **50** which includes hydraulic conduit input **126** and hydraulic conduit output **128**, which are preferably fitted with quick connectors/disconnectors. It will be understood that hydraulic motor **50** is in hydraulic communication with the associated excavator. Hydraulic motor **50** is also in hydraulic communication with drive sprocket **124** via junction box **51** through a conventional drive shaft. Drive sprocket **124** displaces endless chain **80** as

it passes over itself and idler wheel **82**. The displacement of endless chain **80** and bolt-on teeth **81** facilitate trenching of ground and/or soil it contacts.

[0081] In one embodiment of the present invention bracket **18** is associated, on one end, with a boom of an excavator and, on the other end, trencher assembly **10**. However, bracket **18** may also be releasably associated with other accessories **120**, including but not limited to, those disclosed in FIGS. **8A-B**, **9A-B**, **10A-B**, and **13A-B**.

[0082] As is best shown FIGS. **11A-C** and **12A-D**, other adaptors are suitable for use in accordance with the present invention.

[0083] Referring now to FIGS. **14** and **15**, trencher assembly **10**, as well as, associated accessories and adaptors can be releasably associated with a tool kit stand and/or a trailer assembly.

[0084] The foregoing description merely explains and illustrates the invention and the invention is not limited thereto except insofar as the appended claims are so limited, as those skilled in the art who have the disclosure before them will be able to make modifications without departing from the scope of the invention.

What is claimed and desired to be secured by Letters Patent of the United States is:

1. A trencher assembly for use in association with an excavator, comprising:

a body, wherein the body is configured for releasable securement with a boom, a crumber bar, and a bracket; wherein the boom is releasably secured to the body, and further wherein the boom comprises an endless chain having a plurality of displaceable teeth;

wherein the crumber bar is releasably secured to the body, and further wherein the crumber bar is positioned above the boom; and

wherein the bracket is releasably secured to the body, and further wherein the bracket is adapted for releasable securement to the excavator, the tractor, and the like.

2. The trencher assembly according to claim 1, wherein the body comprises a first side wall, a second side wall, and a top wall which collectively form a drive assembly containment region.

3. The trencher assembly according to claim 1, wherein the body comprises a guard plate for shielding a hydraulic motor during operation of the trencher assembly.

4. The trencher assembly according to claim 1, wherein the top wall of the body is associated with a spray guard for limiting displacement of debris during operation of the trencher assembly.

5. The trencher assembly according to claim 1, wherein the housing comprises a crumber bar mounting bracket having a flopper plate positioned on a top wall of the same.

6. The trencher assembly according to claim 1, wherein the boom comprises a tensioner bolt sleeve positioned on a side-wall of the same.

7. The trencher assembly according to claim 1, wherein the boom comprises a tensioner bolt access aperture.

8. The trencher assembly according to claim 1, wherein the crumber bar comprises an inwardly angled tip which extends from a bottom wall to a top wall of the crumber bar.

9. The trencher assembly according to claim 1, wherein the bracket comprises a first side wall, a second side wall, and a

bottom wall which collectively form a substantially U-shaped containment region adapted for receipt of at least a portion of a boom of the excavator, the tractor, and the like.

10. The trencher assembly according to claim **1**, wherein the bracket comprises a connecting sleeve having a pair of aligned apertures for receipt of a securement member.

11. The trencher assembly according to claim **1**, wherein the bracket comprises a plurality of support members which are secured to a connecting sleeve and a bottom wall of the bracket.

12. A trencher assembly for use in association with an excavator, consisting of:

a body, wherein the body is configured for releasable securement with a boom, a crumber bar, and a bracket;
wherein the boom is releasably secured to the body, and further wherein the boom comprises an endless chain having a plurality of displaceable teeth;

wherein the crumber bar is releasably secured to the body, and further wherein the crumber bar is positioned above the boom; and

wherein the bracket is releasably secured to the body, and further wherein the bracket is adapted for releasable securement to the excavator, the tractor, and the like.

13. A trencher assembly for use in combination with a primary boom of an excavator, the combination comprising: an excavator, a tractor, and the like having a primary boom; and

a trencher assembly comprising a body, wherein the body is configured for releasable securement with a secondary boom, a crumber bar, and a bracket;

wherein the secondary boom is releasably secured to the body, and further wherein the secondary boom comprises an endless chain having a plurality of displaceable teeth;

wherein the crumber bar is releasably secured to the body, and further wherein the crumber bar is positioned above the secondary boom; and

wherein the bracket is releasably secured to the body, and further wherein the bracket is secured to the primary boom of the excavator.

14. The trencher assembly according to claim **13**, wherein the bracket comprises a connecting sleeve having a pair of aligned apertures for receipt of a securement member.

15. The trencher assembly according to claim **13**, wherein the bracket comprises a plurality of support members which are secured to a connecting sleeve and a bottom wall of the bracket.

* * * * *