

(12) 특허협력조약에 의하여 공개된 국제출원

(19) 세계지식재산권기구
국제사무국

(43) 국제공개일
2020년 3월 26일 (26.03.2020)



(10) 국제공개번호
WO 2020/060108 A1

- (51) 국제특허분류: *H01M 2/10* (2006.01) *B60K 6/28* (2007.10)
B60L 50/64 (2019.01)
- (21) 국제출원번호: PCT/KR2019/011825
- (22) 국제출원일: 2019년 9월 11일 (11.09.2019)
- (25) 출원언어: 한국어
- (26) 공개언어: 한국어
- (30) 우선권정보: 10-2018-0113243 2018년 9월 20일 (20.09.2018) KR
- (71) 출원인: 주식회사 엘지화학 (LG CHEM, LTD.) [KR/KR]; 07336 서울시 영등포구 여의대로 128, Seoul (KR).
- (72) 발명자: 유정빈 (YOU, Jung-Beon); 34122 대전시 유성구 문지로 188 LG화학기술연구원, Daejeon (KR). 강달모 (KANG, Dal-Mo); 34122 대전시 유성구 문지로 188 LG화학기술연구원, Daejeon (KR). 권민호 (KWON, Min-Ho); 34122 대전시 유성구 문지로 188 LG화학기술연구원, Daejeon (KR). 문정오 (MUN, Jeong-O); 34122 대전시 유성구 문지로 188 LG화학기술연구원, Daejeon (KR). 유재욱 (RYU, Jae-Uk); 34122 대전시 유성구 문지로 188 LG화학기술연구원, Daejeon (KR). 이정훈 (LEE, Jung-Hoon); 34122 대전시 유성구 문지로 188 LG화학기술연구원, Daejeon (KR).
- (74) 대리인: 특허법인 필앤온지 (PHIL & ONZI INT'L PATENT & LAW FIRM); 06643 서울시 서초구 서초중앙로 36, 3층, Seoul (KR).
- (81) 지정국 (별도의 표시가 없는 한, 가능한 모든 종류의 국내 권리의 보호를 위하여): AE, AG, AL, AM, AO, AT, AU, AZ, BA, BB, BG, BH, BN, BR, BW, BY, BZ, CA, CH, CL, CN, CO, CR, CU, CZ, DE, DJ, DK, DM, DO, DZ, EC, EE, EG, ES, FI, GB, GD, GE, GH, GM, GT, HN, HR, HU, ID, IL, IN, IR, IS, JO, JP, KE, KG, KH, KN, KP, KW, KZ, LA, LC, LK, LR, LS, LU, LY, MA, MD, ME, MG, MK, MN, MW, MX, MY, MZ, NA, NG, NI, NO, NZ, OM, PA,

(54) Title: BATTERY MODULE AND BATTERY PACK COMPRISING BATTERY MODULE

(54) 발명의 명칭: 배터리 모듈 및 이러한 배터리 모듈을 포함하는 배터리 팩

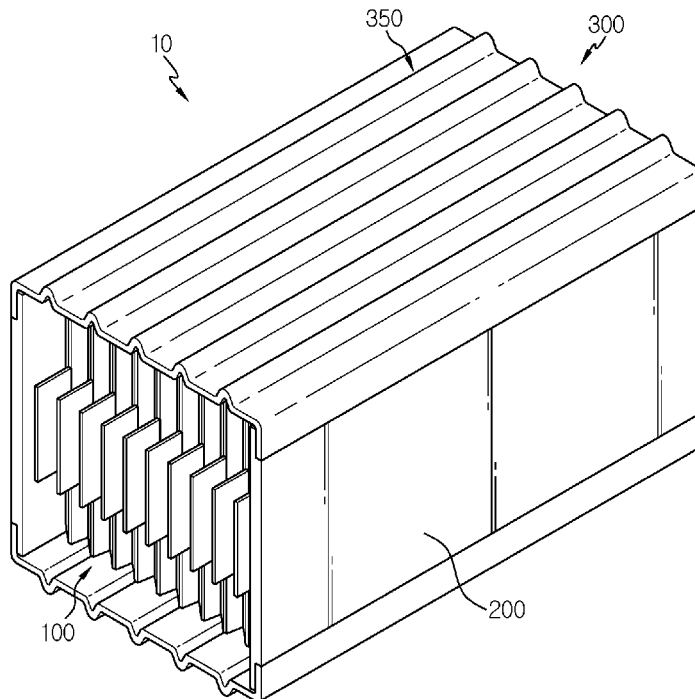

(57) Abstract: A battery module according to an embodiment of the present invention comprises: a battery cell assembly comprising a plurality of battery cells stacked on each other; a pair of end plates provided at the respective sides of the battery cell assembly; and a cover frame coupled to the pair of end plates to cover the battery cell assembly, the cover frame being deformed along the expansion direction of the plurality of battery cells when the plurality of battery cells expand.

(57) 요약서: 본 발명의 일 실시예에 따른 배터리 모듈은, 상호 적층되는 복수 개의 배터리 셀들을 포함하는 배터리 셀 조립체, 배터리 셀 조립체의 양측에 구비되는 한 쌍의 엔드 플레이트 및 한 쌍의 엔드 플레이트와 결합되어 배터리 셀 조립체를 커버하며, 복수 개의 배터리 셀들을 팽창 시 복수 개의 배터리 셀들의 팽창 방향을 따라 변형되는 커버 프레임들을 포함하는 것을 특징으로 한다.

WO 2020/060108 A1

PE, PG, PH, PL, PT, QA, RO, RS, RU, RW, SA, SC, SD, SE, SG, SK, SL, SM, ST, SV, SY, TH, TJ, TM, TN, TR, TT, TZ, UA, UG, US, UZ, VC, VN, ZA, ZM, ZW.

- (84) 지정국 (별도의 표시가 없는 한, 가능한 모든 종류의 역내 권리의 보호를 위하여): ARIPO (BW, GH, GM, KE, LR, LS, MW, MZ, NA, RW, SD, SL, ST, SZ, TZ, UG, ZM, ZW), 유라시아 (AM, AZ, BY, KG, KZ, RU, TJ, TM), 유럽 (AL, AT, BE, BG, CH, CY, CZ, DE, DK, EE, ES, FI, FR, GB, GR, HR, HU, IE, IS, IT, LT, LU, LV, MC, MK, MT, NL, NO, PL, PT, RO, RS, SE, SI, SK, SM, TR), OAPI (BF, BJ, CF, CG, CI, CM, GA, GN, GQ, GW, KM, ML, MR, NE, SN, TD, TG).

공개:

- 국제조사보고서와 함께 (조약 제21조(3))

BATTERY MODULE AND BATTERY PACK COMPRISING BATTERY

MODULE

TECHNICAL FIELD

5 The present disclosure relates to a battery module, a battery pack including the battery module, and a vehicle including the battery pack.

 The present application claims priority to Korean Patent Application No. 10-2018-0113243 filed on September 20, 2018 in the Republic of Korea, the disclosures of which are incorporated herein by reference.

10

BACKGROUND ART

 Secondary batteries which are highly applicable to various products and exhibit superior electrical properties such as high energy density, etc. are commonly used not only in portable devices but also in electric vehicles (EVs) or hybrid electric vehicles (HEVs) driven by electrical power sources. The secondary battery is drawing attentions as a new energy source for enhancing environment friendliness and energy efficiency in that the use of fossil fuels can be reduced greatly and no byproduct is generated during energy consumption.

15

 Secondary batteries widely used at present include lithium ion batteries, lithium polymer batteries, nickel cadmium batteries, nickel hydrogen batteries, nickel zinc batteries and the like. An operating voltage of the unit secondary battery cell, namely a unit battery cell, is about 2.5V to 4.5V. Therefore, if a higher output voltage is required, a plurality of battery cells may be connected in series to configure a battery pack. In

20

addition, depending on the charge/discharge capacity required for the battery pack, a plurality of battery cells may be connected in parallel to configure a battery pack. Thus, the number of battery cells included in the battery pack may be variously set according to the required output voltage or the demanded charge/discharge capacity.

5 Meanwhile, when a plurality of battery cells are connected in series or in parallel to configure a battery pack, it is common to configure a battery module having at least one battery cell first, and then configure a battery pack by using at least one battery module and adding other components.

10 If conventional battery module or battery pack is used for a long time, the battery cells are inflated to gradually increase the internal pressing force. Accordingly, the battery cells or the cover frame for accommodating the battery cells are damaged.

 Thus, it is required to search for a battery module, which may prevent the cover frame or the battery cells from being damaged when the battery cells are inflated, a battery pack including the battery module, and a vehicle including the battery pack.

15

DISCLOSURE

Technical Problem

20 The present disclosure is directed to providing a battery module, which may prevent a cover frame from being damaged when battery cells are inflated, a battery pack including the battery module, and a vehicle including the battery pack.

 Moreover, the present disclosure is also directed to providing a battery module, which may prevent battery cells frame from being damaged when the battery cells are inflated, a battery pack including the battery module, and a vehicle including the battery

pack.

Technical Solution

In one aspect of the present disclosure, there is provided a battery module,
5 comprising: a battery cell assembly having a plurality of battery cells stacked on each other; a pair of end plates provided at both sides of the battery cell assembly; and a cover frame coupled to the pair of end plates to cover the battery cell assembly, the cover frame being deformed along an inflating direction of the plurality of battery cells when the plurality of battery cells are inflated.

10 The inflating direction of the plurality of battery cells may be a direction toward both sides of the battery cell assembly, and the cover frame may have an elastic deforming portion that is elastically deformed in the direction toward both sides of the battery cell assembly when the plurality of battery cells are inflated.

The elastic deforming portion may be formed with a predetermined length along a
15 longitudinal direction of the battery cell assembly and be provided in plural such that the plurality of elastic deforming portions are spaced apart from each other by a predetermined distance along the direction toward both sides of the battery cell assembly.

The plurality of elastic deforming portions may be formed to be convexly protrude out of the cover frame and be concavely formed at an inner side of the cover frame.

20 When the plurality of battery cells are inflated, the plurality of elastic deforming portions may be elastically deformed to become flat along the direction toward both sides of the cover frame.

The elastic deforming portion may have a groove shape with a predetermined size

and be provided in plural such that the plurality of elastic deforming portions are spaced apart from each other by a predetermined distance along a longitudinal direction of the battery cell assembly.

The plurality of elastic deforming portions may include a center groove formed at
5 a center of the cover frame to be formed convex along a front and rear direction of the cover frame; a front edge groove spaced apart from the center groove and provided at a front edge of the cover frame; a plurality of front grooves disposed between the front edge groove and the center groove, spaced apart from each other by a predetermined distance along the front and rear direction of the cover frame, and formed convex toward a front
10 side of the cover frame; a plurality of rear grooves disposed to face the plurality of front grooves with the center groove being interposed therebetween, the plurality of rear grooves being formed convex toward a rear side of the cover frame; and a rear edge groove spaced apart from the plurality of rear grooves and provided at a rear edge of the cover frame.

When the plurality of battery cells are inflated, the center groove, the front edge
15 groove, the plurality of front grooves, the plurality of rear grooves and the rear edge groove may be elastically deformed to become flat along the direction toward both sides of the cover frame.

wherein the center groove may be convexly formed along the front and rear directions of the cover frame.

20 In addition, the present disclosure provides a battery pack, comprising: at least one battery module according to the above embodiments; and a pack case configured to package the at least one battery module.

Advantageous Effects

According to various embodiments as above, it is possible to provide a battery module, which may prevent a cover frame from being damaged when battery cells are inflated, a battery pack including the battery module, and a vehicle including the battery
5 pack.

Moreover, according to various embodiments as above, it is possible to provide a battery module, which may prevent battery cells frame from being damaged when the battery cells are inflated, a battery pack including the battery module, and a vehicle including the battery pack.

10

DESCRIPTION OF DRAWINGS

The accompanying drawings illustrate a preferred embodiment of the present disclosure and together with the foregoing disclosure, serve to provide further understanding of the technical features of the present disclosure, and thus, the present
15 disclosure is not construed as being limited to the drawing.

FIG. 1 is a diagram for illustrating a battery module according to an embodiment of the present disclosure.

FIG. 2 is a cross-sectioned view showing the battery module of FIG. 1.

FIG. 3 is a diagram for illustrating the deformation of a cover frame when battery
20 cells of the battery module of FIG. 1 are inflated.

FIG. 4 is a diagram for illustrating a battery module according to another embodiment of the present disclosure.

FIG. 5 is a diagram for illustrating a cover frame of the battery module of FIG. 4.

FIG. 6 is a diagram for illustrating the deformation of the cover frame when battery cells of the battery module of FIG. 4 are inflated.

FIG. 7 is a diagram for illustrating a battery pack according to an embodiment of the present disclosure.

5 FIG. 8 is a diagram for illustrating a vehicle according to an embodiment of the present disclosure.

BEST MODE

The present disclosure will become more apparent by describing in detail the
10 embodiments of the present disclosure with reference to the accompanying drawings. It should be understood that the embodiments disclosed herein are illustrative only for better understanding of the present disclosure, and that the present disclosure may be modified in various ways. In addition, for ease understanding of the present disclosure, the accompanying drawings are not drawn to real scale, but the dimensions of some
15 components may be exaggerated.

FIG. 1 is a diagram for illustrating a battery module according to an embodiment of the present disclosure, FIG. 2 is a cross-sectioned view showing the battery module of FIG. 1, and FIG. 3 is a diagram for illustrating the deformation of a cover frame when battery cells of the battery module of FIG. 1 are inflated.

20 Referring to FIGS. 1 to 3, the battery module 10 may include a battery cell assembly 100, an end plate 200, and a cover frame 300.

The battery cell assembly 100 may have a plurality of battery cells 110. The plurality of battery cells 110 may be secondary batteries, particularly pouch-type secondary

batteries. The plurality of battery cells 110 may be stacked on each other and electrically connected to each other.

The end plate 200 may be provided in a pair and may be provided at both sides of the battery cell assembly 100. The pair of end plates 200 may support both sides of the
5 battery cell assembly 100.

The cover frame 300 may be coupled to the pair of end plates 200 to cover the battery cell assembly 100. The cover frame 300 may cover at least an upper side and a lower side of the pair of end plates 200.

When the plurality of battery cells 110 are inflated, the cover frame 300 may be
10 deformed along the inflating direction of the plurality of battery cells 110. Here, the inflating direction of the plurality of battery cells 110 may be a direction toward both sides of the battery cell assembly 100, namely toward the pair of end plates 200.

The cover frame 300 may have an elastic deforming portion 350 for the elastic deformation.

15 When the plurality of battery cells 110 are inflated, the elastic deforming portion 350 may elastically deformed in the direction toward both sides of the battery cell assembly 100 to extend the cover frame 300 in the direction toward both sides of the battery cell assembly 100.

The elastic deforming portion 350 may be formed with a predetermined length
20 along the longitudinal direction of the battery cell assembly 100, namely in the front and rear directions of the battery module 10, and may be provided in plural such that the plurality of elastic deforming portions 350 are spaced apart from each other by a predetermined distance along the direction toward both sides of the battery cell assembly

100.

The plurality of elastic deforming portions 350 may be formed to convexly protrude out of the cover frame 300 and may be concavely formed at an inner side of the cover frame 300, respectively.

5 When the plurality of battery cells 110 are inflated, the plurality of elastic deforming portions 350 may be elastically deformed to become flat along the direction toward both sides of the cover frame 300. When the plurality of battery cells 110 are inflated, the plurality of elastic deforming portions 350 may be elastically deformed to extend the cover frame 300 to a predetermined length in the inflating direction, thereby
10 guiding deformation of the cover frame 300.

Accordingly, in this embodiment, it is possible to effectively prevent the inner pressing force of the battery module 10 from increasing beyond a predetermined magnitude by means of the elastic deforming portion 350 when the plurality of battery cells 110 are inflated.

15 Thus, in this embodiment, when the plurality of battery cells 110 are inflated, the elastic deforming portion 350 may prevent the pressing force of the battery module 10 from increasing beyond a predetermined magnitude, thereby significantly reducing the risk of damage of the battery cells 110 or the cover frame 300.

FIG. 4 is a diagram for illustrating a battery module according to another
20 embodiment of the present disclosure, FIG. 5 is a diagram for illustrating a cover frame of the battery module of FIG. 4, and FIG. 6 is a diagram for illustrating the deformation of the cover frame when battery cells of the battery module of FIG. 4 are inflated.

Since the battery module 20 according to this embodiment is similar to the battery

module 10 of the former embodiment, the features identical or similar to those of the former embodiment will not be described in detail, and features different from the former embodiment will be described in detail.

Referring to FIGS. 4 to 6, the battery module 20 may include a battery cell assembly 100, an end plate 200 and a cover frame 400.

The battery cell assembly 100 and the end plate 200 are substantially identical or similar to those of the former embodiment and thus will be described in detail.

The cover frame 400 may have an elastic deforming portion 450.

The elastic deforming portion 450 has a groove shape with a predetermined size and may be provided in plural such that the plurality of deforming portions 450 are spaced apart from each other by a predetermined distance along the longitudinal direction of the battery cell assembly 110.

The elastic deforming portion 450 may have a center groove 451, a front edge groove 453, a front groove 455, a rear groove 457, and a rear edge groove 459.

The center groove 451 may be formed at the center of the cover frame 400. The center groove 451 may be convexly formed along the front and rear directions of the cover frame 400.

The front edge groove 453 may be spaced apart from the center groove 451 at the front side of the cover frame 400. The front edge groove 453 may be provided at the front edge of the cover frame 400.

The front groove 455 may be provided in plural and disposed between the front edge groove 453 and the center groove 451. The front grooves 455 may be spaced apart from each other by a predetermined distance along the front and rear direction of the cover

frame 400 and be formed convex toward a front side of the cover frame 400.

The rear groove 457 is provided in plural, and the plurality of rear grooves 457 are disposed to face the plurality of front grooves 455 with the center groove 451 being interposed therebetween. The rear groove 457 may be formed convex toward a rear side
5 of the cover frame 400.

The rear edge groove 459 may be spaced apart from the plurality of rear grooves 457. The rear edge groove 459 may be provided at a rear edge of the cover frame 400.

When the plurality of battery cells 110 are inflated, the center groove 451, the front edge groove 453, the plurality of front grooves 455, the plurality of rear grooves 457,
10 and the rear edge groove 459 may be elastically deformed to become flat along the direction toward both sides of the cover frame 400.

Accordingly, when the plurality of battery cells 110 are inflated, the elastic deforming portion 450 may extend the cover frame 400 by a predetermined length in the inflating direction to guide deformation of the cover frame 400.

As described above, the elastic deforming portion 450 may be formed with a
15 plurality of straps with a bent groove shape capable of elastically extending the cover frame 400, instead of the shape of the former embodiment.

FIG. 7 is a diagram for illustrating a battery pack according to an embodiment of the present disclosure, and FIG. 8 is a diagram for illustrating a vehicle according to an
20 embodiment of the present disclosure.

Referring to FIGS. 7 and 8, a battery pack 1 may include at least one battery module 10 according to the former embodiment and a pack case 50 for packaging the at least one battery module 10.

The battery pack 1 may include at least one battery module 20 of the former embodiments, or may include both the battery modules 10, 20 of the former embodiments.

The battery pack 1 may be provided to a vehicle V as a fuel source of the vehicle V. As an example, the battery pack 1 may be provided to a vehicle V such as an electric
5 vehicle, a hybrid vehicle, and various other-type vehicles capable of using the battery pack 1 as a fuel source.

In addition, the battery pack 1 may be provided in other devices, instruments or facilities such as an energy storage system using a secondary battery, in addition to the vehicle V.

10 As described above, the battery pack 1 of this embodiment and devices, instruments or facilities such as a vehicle V, which have the battery pack 1, include the battery module 10, 20 as described above, and thus it is possible to implement a battery pack 1 having all the advantages of the battery module 10, 20 described above, or devices, instruments, facilities or the like such as a vehicle V, which have the battery pack 1.

15 According to various embodiments as above, it is possible to provide the battery module 10, 20, which may prevent the cover frame 300, 400 from being damaged when the battery cells 110 are inflated, the battery pack 1 including the battery module 10, 20, and the vehicle V including the battery pack 1.

Moreover, according to various embodiments as above, it is possible to provide the
20 battery module 10, 20, which may prevent the battery cells 110 frame from being damaged when the battery cells 110 are inflated, the battery pack 1 including the battery module 10, 20, and the vehicle V including the battery pack 1.

While the embodiments of the present disclosure have been shown and described,

it should be understood that the present disclosure is not limited to the specific embodiments described, and that various changes and modifications can be made within the scope of the present disclosure by those skilled in the art, and these modifications should not be understood individually from the technical ideas and views of the present

5 disclosure.

WHAT IS CLAIMED IS:

1. A battery module, comprising:
a battery cell assembly having a plurality of battery cells stacked on each other;
5 a pair of end plates provided at both sides of the battery cell assembly; and
a cover frame coupled to the pair of end plates to cover the battery cell assembly,
the cover frame being deformed along an inflating direction of the plurality of battery cells
when the plurality of battery cells are inflated.

- 10 2. The battery module according to claim 1,
wherein the inflating direction of the plurality of battery cells is a direction toward
both sides of the battery cell assembly, and
wherein the cover frame has an elastic deforming portion that is elastically
deformed in the direction toward both sides of the battery cell assembly when the plurality
15 of battery cells are inflated.

3. The battery module according to claim 2,
wherein the elastic deforming portion is formed with a predetermined length along
a longitudinal direction of the battery cell assembly and is provided in plural such that the
20 plurality of elastic deforming portions are spaced apart from each other by a predetermined
distance along the direction toward both sides of the battery cell assembly.

4. The battery module according to claim 3,

wherein the plurality of elastic deforming portions are formed to be convexly protrude out of the cover frame and are concavely formed at an inner side of the cover frame.

5 5. The battery module according to claim 4,

wherein when the plurality of battery cells are inflated, the plurality of elastic deforming portions are elastically deformed to become flat along the direction toward both sides of the cover frame.

10 6. The battery module according to claim 2,

wherein the elastic deforming portion has a groove shape with a predetermined size and is provided in plural such that the plurality of elastic deforming portions are spaced apart from each other by a predetermined distance along a longitudinal direction of the battery cell assembly.

15

7. The battery module according to claim 6,

wherein the plurality of elastic deforming portions include:

a center groove formed at a center of the cover frame to be formed convex along a front and rear direction of the cover frame;

20 a front edge groove spaced apart from the center groove and provided at a front edge of the cover frame;

a plurality of front grooves disposed between the front edge groove and the center groove, spaced apart from each other by a predetermined distance along the front and rear

direction of the cover frame, and formed convex toward a front side of the cover frame;

a plurality of rear grooves disposed to face the plurality of front grooves with the center groove being interposed therebetween, the plurality of rear grooves being formed convex toward a rear side of the cover frame; and

5 a rear edge groove spaced apart from the plurality of rear grooves and provided at a rear edge of the cover frame.

8. The battery module according to claim 7,

10 wherein when the plurality of battery cells are inflated, the center groove, the front edge groove, the plurality of front grooves, the plurality of rear grooves and the rear edge groove are elastically deformed to become flat along the direction toward both sides of the cover frame.

9. The battery module according to claim 7,

15 wherein the center groove convexly formed along the front and rear directions of the cover frame.

10. A battery pack, comprising:

at least one battery module according to claim 1; and

20 a pack case configured to package the at least one battery module.

FIG. 1

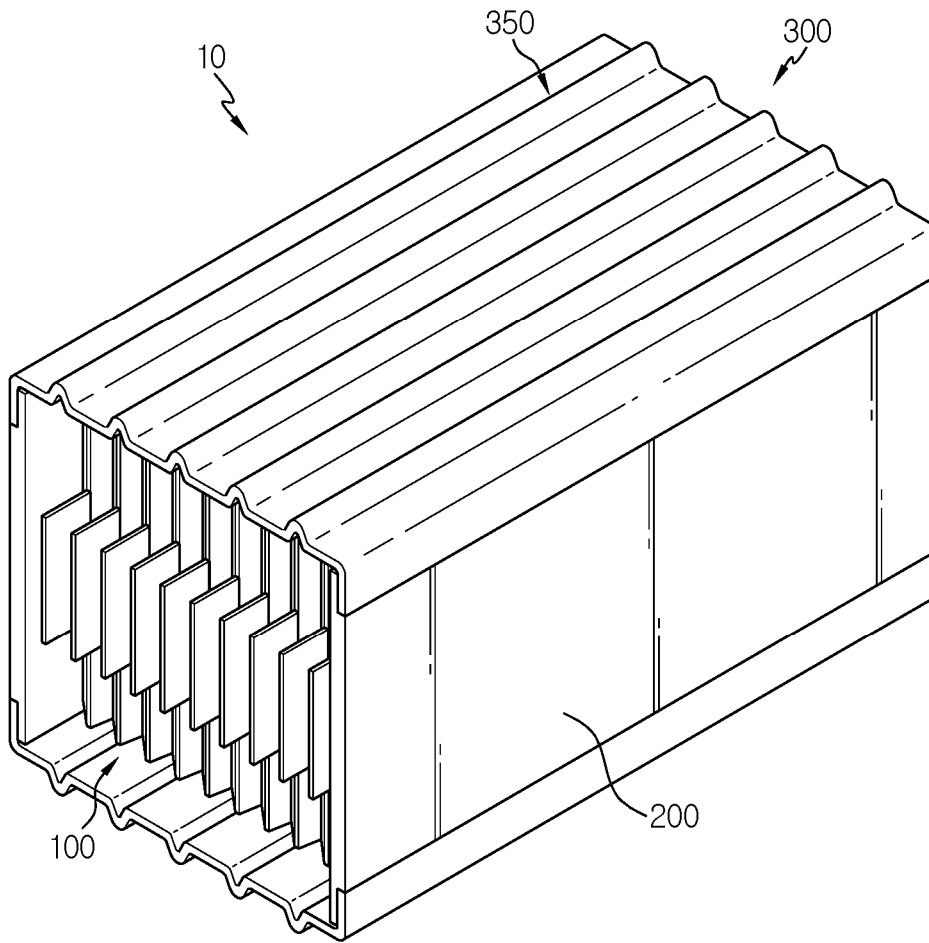

FIG. 2

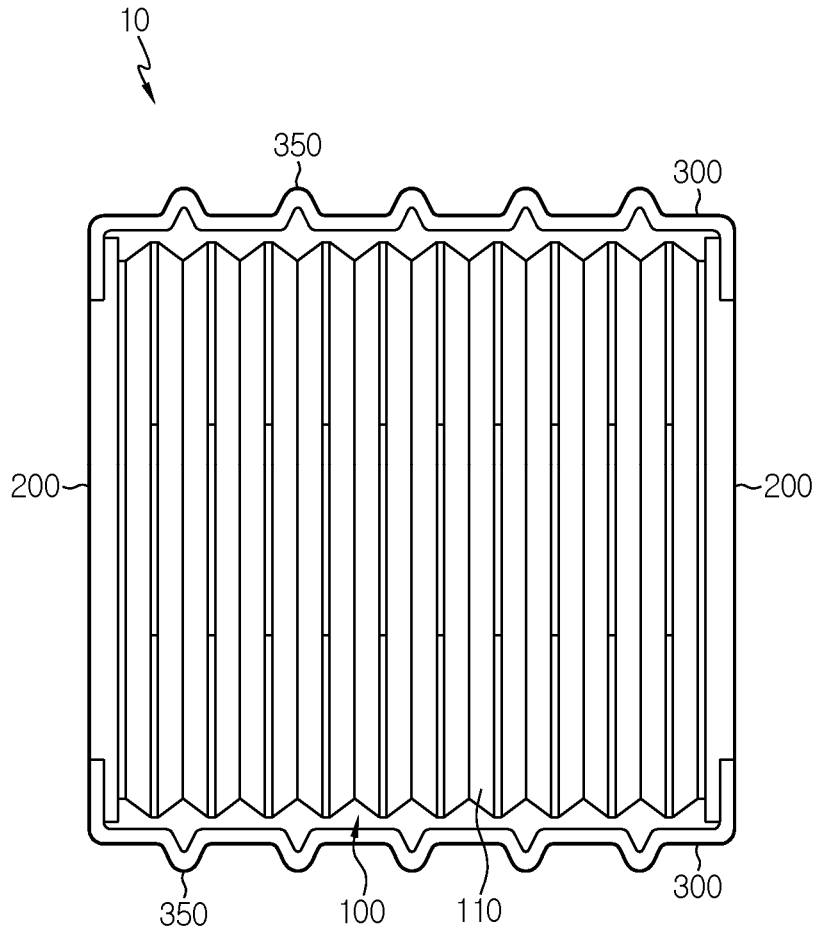

FIG. 3

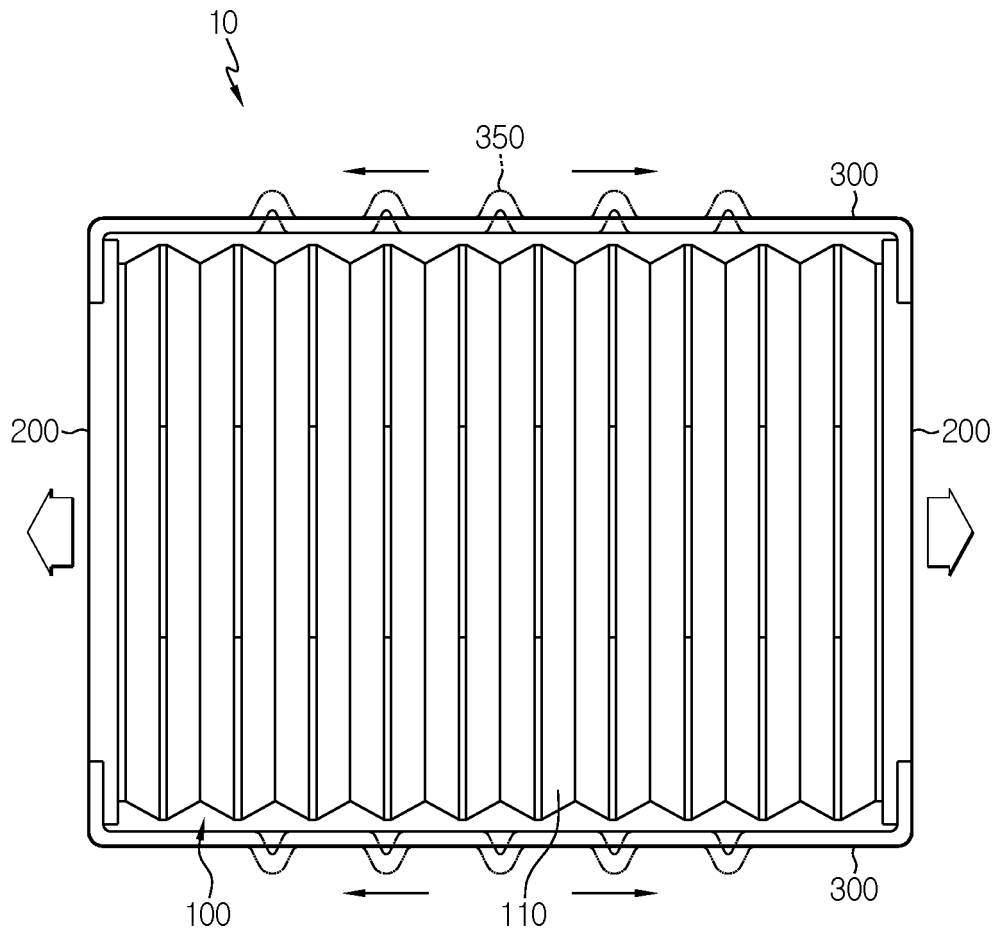

FIG. 4

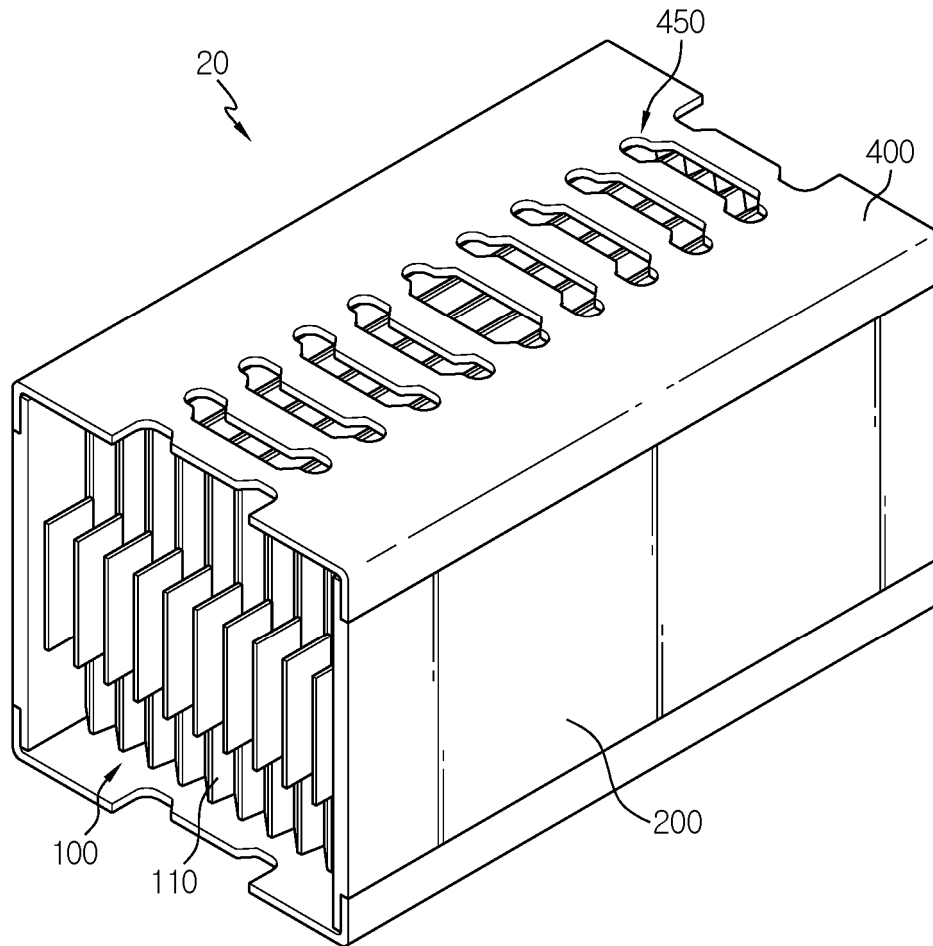

FIG. 5

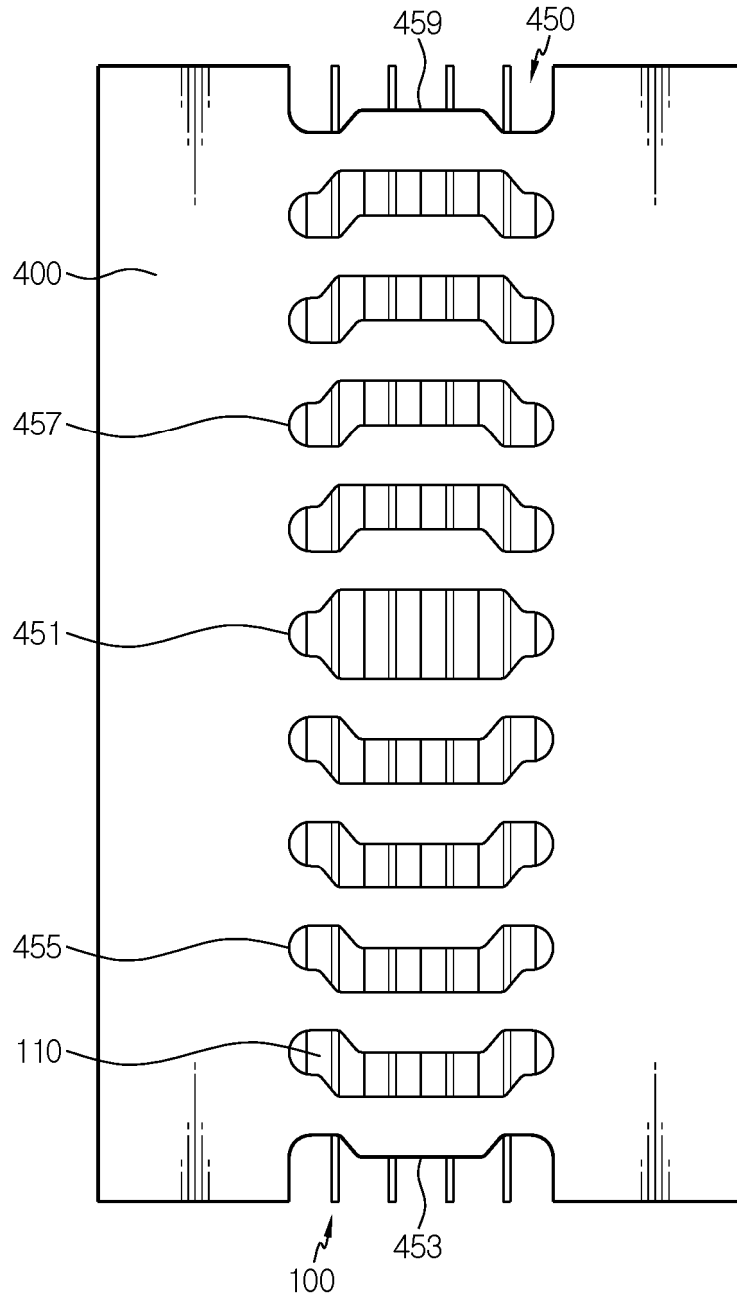

FIG. 6

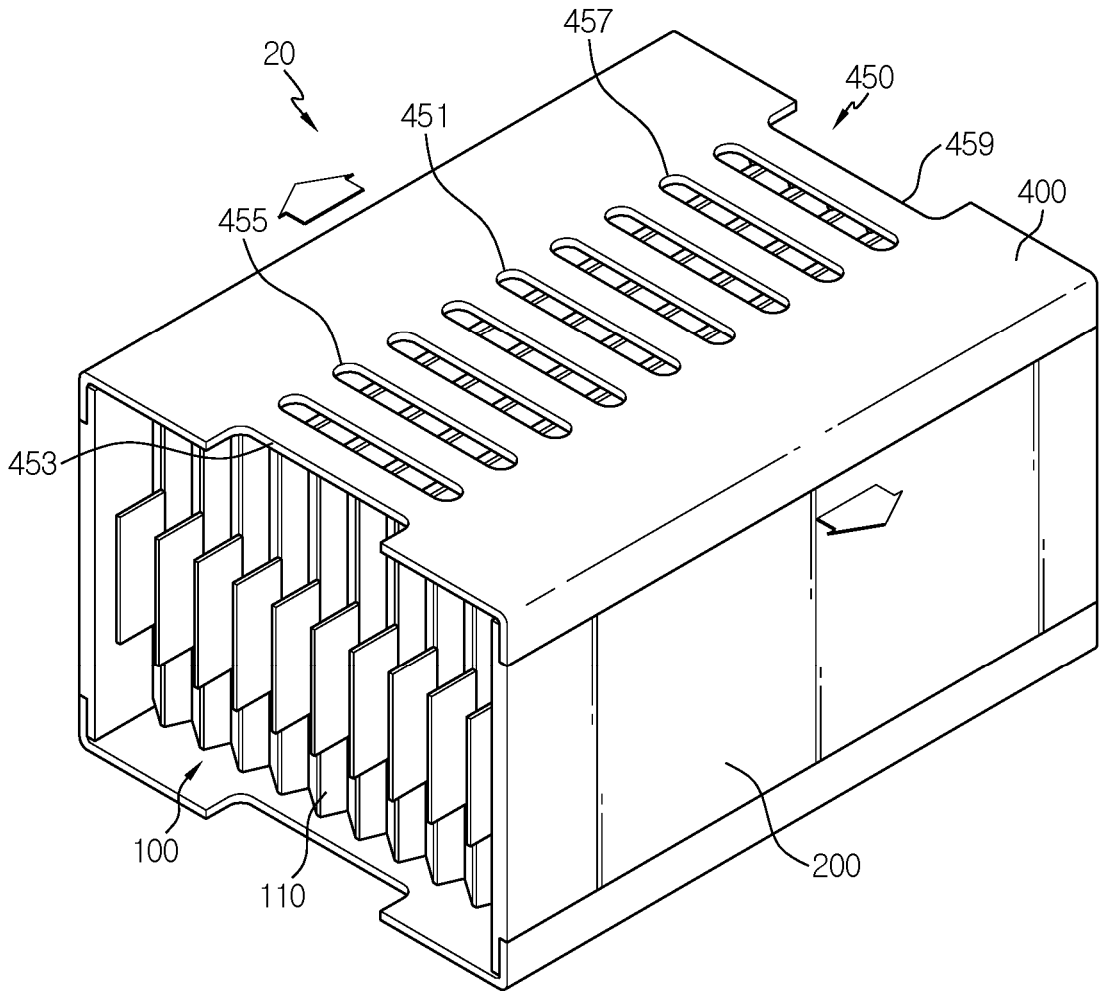

FIG. 7

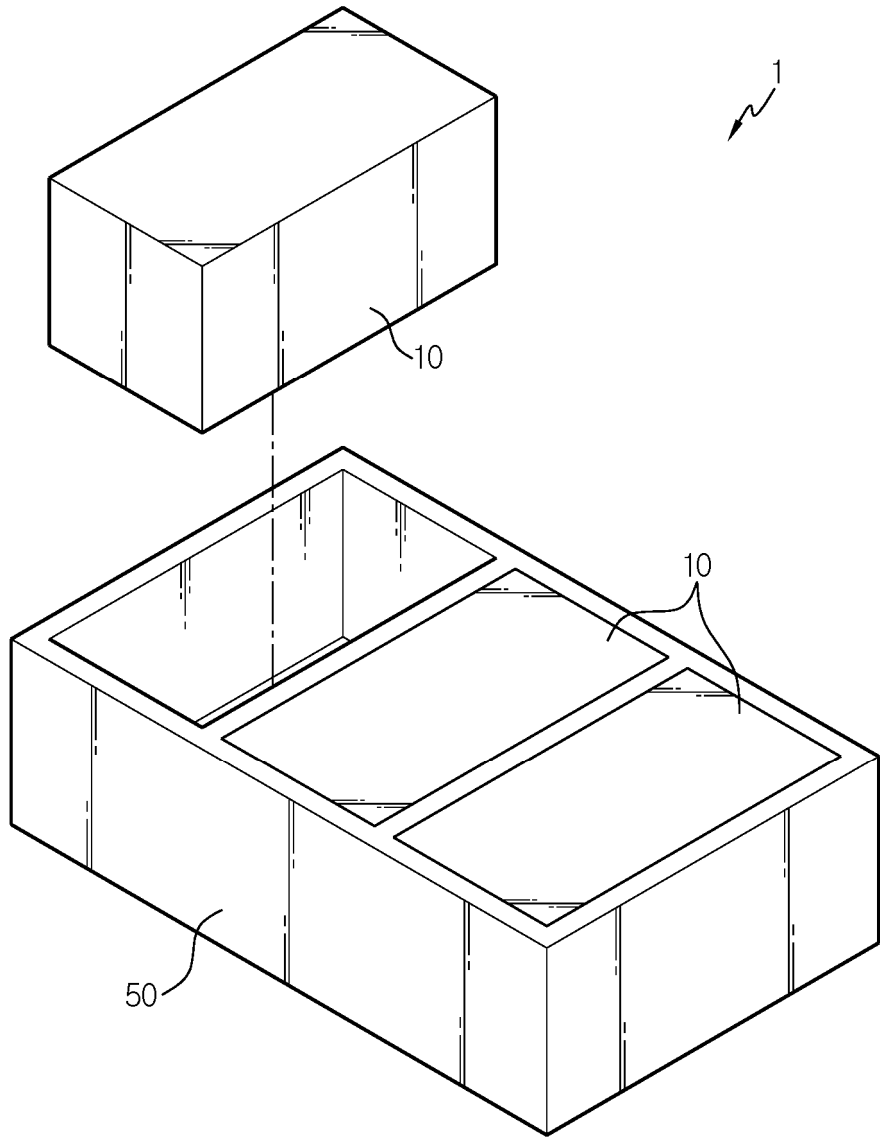

FIG. 8

