

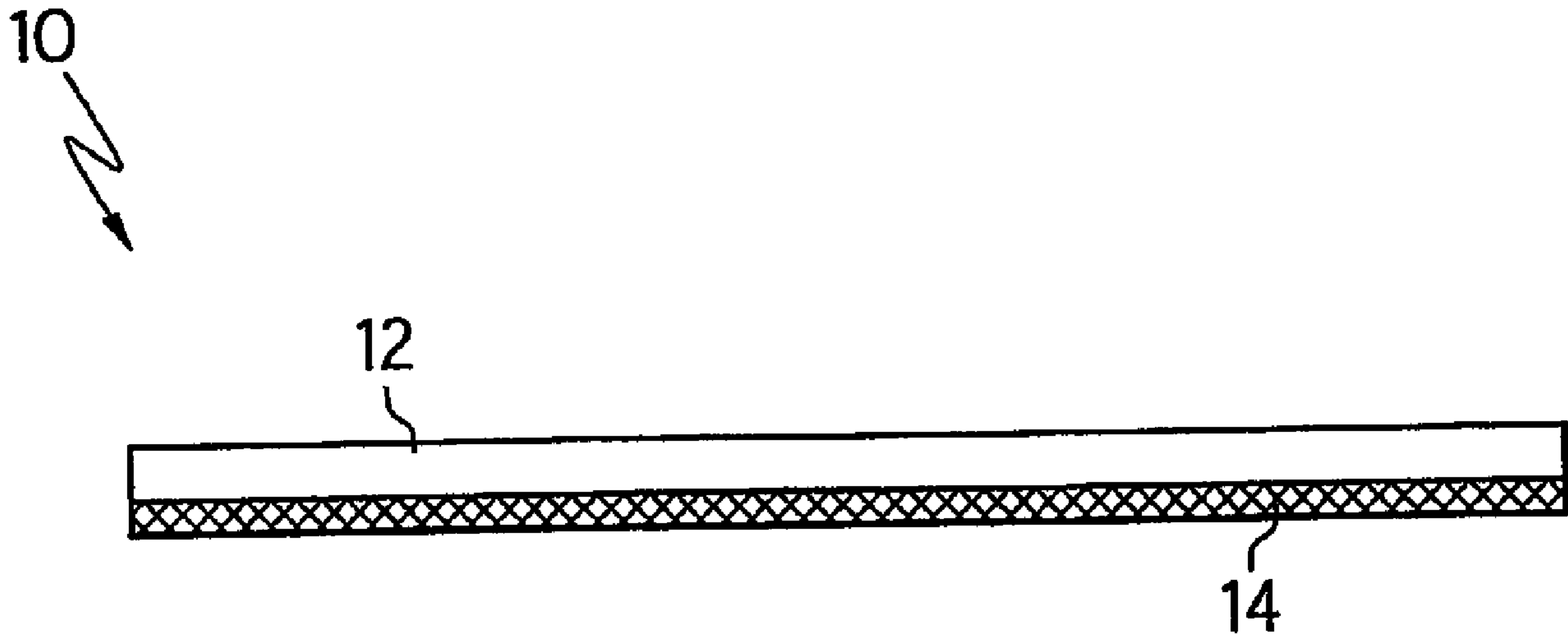

(22) Date de dépôt/Filing Date: 2001/11/21  
 (41) Mise à la disp. pub./Open to Public Insp.: 2002/05/30  
 (45) Date de délivrance/Issue Date: 2013/05/14  
 (62) Demande originale/Original Application: 2 428 879  
 (30) Priorité/Priority: 2000/11/26 (US60/253,191)

(51) Cl.Int./Int.Cl. *H01F 41/14* (2006.01),  
*B32B 27/18* (2006.01), *G09F 3/08* (2006.01),  
*G09F 7/04* (2006.01), *B42D 5/00* (2006.01)  
 (72) Inventeurs/Inventors:  
 BOUDOURIS, RANDALL, US;  
 RICHARDS, RAYMOND S., US  
 (73) Propriétaire/Owner:  
 MAGNETNOTES, LTD., US  
 (74) Agent: PIASETZKI NENNIGER KVAS LLP

(54) Titre : SUBSTRATS MAGNETIQUES, COMPOSITION ET PROCEDE PERMETTANT DE LES FABRIQUER  
 (54) Title: MAGNETIC SUBSTRATES, COMPOSITION AND METHOD FOR MAKING THE SAME



(57) Abrégé/Abstract:

A process of making a magnetic assembly having at least one magnetic layer and at least one printable substrate layer including the steps of providing a magnetic composition comprising about 70 wt-% to about 95 wt-% of at least one magnetic material and about 5 wt-% to about 30 wt-% of at least one thermoplastic binder, forming the magnetic composition into a magnetic layer, and directly applying the magnetic compositions at an elevated temperature in molten form to a printable substrate layer, and to the magnetic composition and any articles made therefrom.



**ABSTRACT OF THE DISCLOSURE**

A process of making a magnetic assembly having at least one magnetic  
5 layer and at least one printable substrate layer including the steps of providing a  
magnetic composition comprising about 70 wt-% to about 95 wt-% of at least one  
magnetic material and about 5 wt-% to about 30 wt-% of at least one  
thermoplastic binder, forming the magnetic composition into a magnetic layer,  
and directly applying the magnetic compositions at an elevated temperature in  
10 molten form to a printable substrate layer, and to the magnetic composition and  
any articles made therefrom.

## MAGNETIC SUBSTRATES, COMPOSITION AND METHOD FOR MAKING THE SAME

5

### FIELD OF THE INVENTION

10           The present invention relates to a method of making a magnetic, printable assembly that will self-adhere to a magnetically attracted surface, a magnetic composition for making the same, and articles made therefrom.

### BACKGROUND OF THE INVENTION

15           Flexible permanent magnetic materials are often supplied in the form of sheets or rolls and have been commercially available for many years. These materials are typically prepared by mixing a powdered ferrite material with a suitable polymeric or plastic binder into a uniform mixture. The polymeric materials are often elastomers, and the process is therefore typically accomplished through the use of sheet extrusion or  
20           calendering. The mixture is converted into strip or sheet form, providing a permanent stable product that is usually somewhat flexible, and that can readily be handled and made into elements of any desired shape by cutting and/or stamping.

          The magnetic material is permanently magnetized so that the resulting elements can act individually as permanent magnets, the magnetic field being of  
25           sufficient strength that they will adhere to a magnetically attracted surface, such as the surface of an iron or steel sheet, even through a sheet of paper or thin cardboard. Many magnetic materials and the resultant sheet materials are typically inherently dark in color and it is therefore usual to attach these magnets to a printable substrate such as paper or plastic by gluing. It is therefore to the paper or plastic that the decorative pattern and/or  
30           other information may be printed. A popular application of such materials is thin, flat magnets having on their outer surface a decorative pattern and/or promotional



information, including advertisements in direct mailings, newspaper inserts, and so forth, box toppers, coupons, business cards, calendars, greeting cards, postcards, and so forth.

These magnetic pieces may then be placed on a magnetically attracted surface such as a refrigerator, file cabinet, or other surface where they may be used as  
5 reminders and are often used to hold sheets of paper such as notes, recipes, lists, children's artwork, reminders, and so on.

In the usual manufacture of these items, multiple producers are involved in the process. For example, a printer produces the printed matter on wide web presses or individual sheets. If in web form, the web is cut into individual sheets and then  
10 shipped to a magnet manufacturer where the magnetic material and the printed matter are joined through the use of an adhesive layer. Alternatively, the printer may purchase or otherwise obtain magnets and then join the printed matter to the magnets through the use of an adhesive layer, or may have both pieces shipped to a third party where the pieces may be joined through the use of an adhesive layer.

15 There remains a need in the art to simplify the production process of such magnetic pieces.

#### SUMMARY OF THE INVENTION

The present invention relates to a unitary process of making a magnetic,  
20 printable assembly in which at least one magnetic layer may be directly formed and joined to a printable layer without the use of an additional adhesive layer. The adhesion between the magnetic layer and the printable substrate is sufficient so that no additional adhesive is required. The process allows for formation of the magnetic layer and joining of the magnetic layer to a printable substrate during a single process. The formation and  
25 joining are accomplished at an elevated temperature sufficient to provide the magnetic layer in pliable or plastic form.

The process may further include a magnetization step which may be accomplished either when the magnetic layer is at an elevated temperature, or when it has cooled to ambient temperatures.

30 The magnetic layer comprises from about 70 wt-% to about 95 wt-% of at least one magnetic material and about 5 wt-% to about 30 wt-% of at least one

thermoplastic material.

In one embodiment of the present invention, the magnetic material has the general formula  $M^{2+}O_6Fe_2O_3$  ( $MFe_{12}O_{19}$ ) where M is a divalent metal. Suitably, M is barium, strontium or lead. In some embodiments, the polymeric binder includes at least  
5 one amorphous polypropylene.

The process involves application of the magnetic layer directly to the printable substrate at elevated temperatures wherein the magnetic layer is pliable and or in a plastic form. The process has the advantage that no additional adhesive layer is required.

10

#### BRIEF DESCRIPTION OF THE DRAWINGS

Fig. 1 is a cross-sectional side view of the magnetic assembly of the present invention.

Fig. 2 illustrates an embodiment of the present invention in which the  
15 magnetic layer is found in a discrete location on a printable substrate layer.

Fig. 3 illustrates an embodiment in which the magnetic layer is substantially equal in length and width to the printable substrate layer.

Fig. 4a is a perspective view of the magnetic label assembly of the present invention shown provided on an article.

20 Fig. 4b is an alternative embodiment to that shown in fig. 4a in which the magnetic assembly is further provided with an overlamine.

Fig. 5 illustrates an embodiment of the magnetic assembly of the present invention in which individual pieces may be produced from a sheet or web material.

25 Fig. 6 illustrates an alternative embodiment as that shown in fig. 5 in which the magnetic layer is located in discrete areas along the web or sheet of printable substrate.

Fig. 7 is a perspective view of an embodiment of the present invention in showing a collection of a plurality of individual magnetic assemblies.

30 Fig. 8 illustrates one embodiment of the magnetic assembly of the present invention.

Fig. 9 illustrates an alternative embodiment of the magnetic assembly of



the present invention.

Fig. 10 illustrates another alternative embodiment of the magnetic assembly of the present invention.

Fig. 11 is a side view of one embodiment of the magnetic assembly of the present invention further including a release liner and an overlamine.

Fig. 12 is a top down view of the embodiment shown in fig. 11 in which the overlamine further includes perforations.

Fig. 13 shows the embodiment described in figs. 11 and 12 in sheet form.

Fig. 14 is a side view of an alternative embodiment of the magnetic assembly of the present invention.

Fig. 15 is a top down view of the embodiment shown in fig. 14.

#### DETAILED DESCRIPTIONS OF THE PREFERRED EMBODIMENTS

The following description is intended for illustrative purposes only, and is not intended as a limit on the scope of the present invention. One of skill in the art will recognize various alternative embodiments and variations of the embodiments which also may be employed herein.

The present invention relates to a novel method of making a printable, magnetic assembly, and to a magnetic composition and articles made therefrom.

The magnetic substrate layer may suitably include about 75 weight % to about 95 weight %, more suitably about 80 weight % to about 92 weight %, and most suitably about 85 wt-% to about 90 wt-% of a magnetic material, suitably about 5 wt-% to about 25 wt-%, more suitably about 8 wt-% to about 20 wt-% and most suitably about 10 wt-% to about 15 wt-% of a polymeric binder. The magnetic material is uniformly dispersed in the polymeric binder.

As used herein, the term "magnetic"(when applied to a substrate, article, object, etc.) shall refer to any material which exhibits a permanent magnetic behavior or is readily permanently magnetized.

Magnetic materials which are particularly suitable for use herein include the ferrites having the general formula  $(M^{2+}O_6Fe_2O_3) MFe_{12}O_{19}$  where M represents Ba or Sr.

Other examples of magnetic materials suitable for use herein include a rare earth-cobalt magnet of  $\text{RCO}_5$ , where R is one or more of the rare earth elements such as Sm or Pr, yttrium (Y), lanthanum (La), cerium (Ce), and so forth.

Other specific examples of magnetic materials include, for instance,  
5 manganese-bismuth, manganese-aluminum, and so forth.

The method of the present invention is not limited to any particular magnetic material, and the scope of the invention is therefore not intended to be limited as such. While the above described materials find particular utility in the process of the present invention, other materials which are readily permanently magnetized may also  
10 find utility herein.

The magnetic composition suitably includes about 70 wt-% or more of the magnetic material as to have a sufficient attractive force for practical uses. However, it is usually impractical to employ more than 95 wt-% of the magnetic material because of production concerns, and also because of the difficulty of retaining more than this in the  
15 binder material. Furthermore, including more than about 95 wt-% of the magnetic material may lead to a rougher surface. The magnetic material is often supplied in a powder form.

The magnetic strength of the finished product is a function of the amount of magnetic material or powder in the mix, the surface area, thickness, and method of  
20 magnetization (e.g. whether it is aligned or not).

The thermoplastic material, often referred to in the industry as a thermoplastic binder, suitable for use in the process of the present invention may include any polymeric material that is readily processable with the magnetic material on, for instance, the thermoplastic or hot melt processing equipment as described in detail  
25 below. Such thermoplastic materials include both thermoplastic elastomers and non-elastomers or any mixture thereof.

The thermoplastic composition may be selected based on, for one, the type of printable substrate which is being used, and the adhesion obtained between the thermoplastic composition and the printable substrate.

30 Examples of thermoplastic elastomers suitable for use herein include, but are not limited to, natural and synthetic rubbers and rubbery block copolymers, such as



butyl rubber, neoprene, ethylene-propylene copolymers (EPM), ethylene-propylene-diene polymers (EPDM), polyisobutylene, polybutadiene, polyisoprene, styrene-butadiene (SBR), styrene-butadiene-styrene (SBS), styrene-ethylene-butylene-styrene (SEBS), styrene-isoprene-styrene (SIS), styrene-isoprene (SI), styrene-ethylene/propylene (SEP),  
5 polyester elastomers, polyurethane elastomers, to mention only a few, and so forth and mixtures thereof. Where appropriate, included within the scope of this invention are any copolymers of the above described materials.

Examples of suitable commercially available thermoplastic elastomers such as SBS, SEBS, or SIS copolymers include KRATON® G (SEBS or SEP) and  
10 KRATON® D (SIS or SBS) block copolymers available from Kraton Polymers; VECTOR® (SIS or SBS) block copolymers available from Dexco Chemical Co.; and FINAPRENE® (SIS or SBS) block copolymers available from Atofina.

Some examples of non-elastomeric polymers include, but are not limited to, polyolefins including polyethylene, polypropylene, polybutylene and copolymers and  
15 terpolymers thereof such as ethylene vinyl acetate copolymers (EVA), ethylene n-butyl acrylates (EnBA), ethylene methyl (meth) acrylates including ethylene methyl acrylates (EMA), ethylene ethyl (meth) acrylates including ethylene ethyl acrylates (EEA), interpolymers of ethylene with at least one C<sub>3</sub> to C<sub>20</sub> alphaolefin, polyamides, polyesters, polyurethanes, to mention only a few, and so forth, and mixtures thereof. Where  
20 appropriate, copolymers of the above described materials also find utility herein.

Examples of polymers useful herein may be found in US 6262174. Polymeric compositions exhibiting high hot tack have been found to be particularly suitable for use herein. Hot tack is a term of art known to those of ordinary skill.

Examples of commercially available non-elastomeric polymers include  
25 EnBA copolymers available from such companies as Atofina under the tradename of LOTRYL®, from ExxonMobil under the tradename of ESCORENE®, from Du Pont de Nemours & Co. under the tradename of ELVALOY®; EMA copolymers available from Exxon Chemical Co. under the tradename of OPTEMA®; EVA copolymers are available from Du Pont under the tradename of ELVAX® and from Equistar under the tradename  
30 of ULTRATHENE® to name only a few.



In some embodiments of the present invention, the binder includes at least one polyolefin or polyalphaolefin, or a copolymer or terpolymer thereof. Examples of useful polyolefins include, but are not limited to, amorphous (i.e. atactic) polyalphaolefins (APAO) including amorphous propylene homopolymers, 5 propylene/ethylene copolymers, propylene/butylene copolymers and propylene/ethylene/butylene terpolymers; isotactic polyalphaolefins; and linear or substantially linear interpolymers of ethylene and at least one alpha-olefin including, for instance, ethylene and 1-octene, ethylene and 1 butene, ethylene and 1-hexene, ethylene and 1-pentene, ethylene and 1-heptene, and ethylene and 4-methyl-1-pentene and so 10 forth. In some embodiments, it may be preferable to employ a small amount of another polymer in combination with the polyalphaolefin such as maleic anhydride grafted polymers which have been used to improve wetting and adhesion. Other chemical grafting can be used, but maleic anhydride is by far the most common. Usually only a few percent in grafting (1-5%) are used and most tend to be ethylene or propylene 15 copolymers.

The terms "polyolefin" and "polyalphaolefin" are often used interchangeably, and in fact, are often used interchangeably to describe amorphous polypropylenes (homo-, co- and terpolymers). For a detailed description of such materials, see US 5482982, US 5478891 and US 5397843, 4857594.

20 The term "alpha" is used to denote the position of a substituting atom or group in an organic compound.

As used herein, the terms "copolymer" and "interpolymer" shall be used to refer to polymers having two or more different comonomers, e.g. copolymer, terpolymer, and so forth.

25 Examples of commercially available amorphous polyolefins suitable for use herein include those available under the tradename of REXTAC® from Huntsman Polymers including polypropylene homopolymers, propylene/ethylene copolymers and propylene-butene copolymers; VESTOPLAST® APAOs available from Hüls including homopolymers and copolymers, as well as terpolymers of propylene/ethylene/butene; as 30 well as those available from Rexene and those available under the tradename of

EASTOFLEX® available from Eastman Chemical Co. in Kingsport, TN.

Examples of copolymers of a polyolefin and at least one alpha-olefin include metallocene catalyzed polyolefins (interpolymers of ethylene and at least one alphaolefin) commercially available from Exxon under the tradename EXXACT®, and  
5 from DupontDow Elastomers under the tradename ENGAGE®, and from Dow under the tradename AFFINITY®.

In one particular embodiment, the binder is an amorphous polyalphaolefin available from Eastman Chemical Co. under the tradename of EASTOFLEX®.

Amorphous polyalphaolefins when used in combination with the magnetic material have  
10 been found to provide excellent adhesion to the printable substrate without the need for further formulation. However, some polymeric materials may require the addition of tackifying resins, plasticizers, and so forth to provide adequate adhesion. The addition of low molecular weight plasticizers and/or tackifying resins can also improve the processability of the composition as well by changing rheological properties and/or  
15 lowering the melt viscosity of the composition.

Any of the polymeric materials useful herein may be used in combination with one another. Furthermore, other polymeric materials not specifically described herein also find utility in the present invention. The list described above is intended for illustrative purposes only, and is not intended to limit the scope of the present invention.  
20 One of skill in the art would understand that there are vast numbers of polymeric materials available that may find utility herein.

Tackifying resins are available from numerous sources including many of the companies described above, and include, for instance, hydrocarbon tackifying resins such as those available from Eastman Chemical Co. under the tradename of  
25 EASTOTAC®; ESCOREZ® petroleum hydrocarbon resins available from ExxonMobil; PICCOTAC® and PICCOLYTE® polyterpene resins available from Hercules; FORAL® hydrogenated rosins and rosin ester resins available from Hercules; WINGTAC® petroleum hydrocarbon resins available from Goodyear; REGALREZ® hydrocarbon resins and REGALITE® hydrogenated aromatic resins available from Hercules Inc.; and  
30 so on and so forth.

Plasticizers are available from many sources and include plasticizing oils,



for instance. Plasticizing oils are often petroleum based and are available from various petroleum companies.

Waxes may also be optionally added to the compositions to lower the melt viscosity and/or change rheological characteristics.

5 Other optional ingredients include, but are not limited to, antioxidants, dyes or pigments, UV agents, and so forth. Such optional ingredients are known to those of skill in the art and are typically added in low concentrations which do not adversely affect the physical characteristics of the composition.

The list of materials described above is intended for illustrative purposes  
10 only, and is by no means exclusive of the materials which may be employed in the magnetic composition herein, and as such is not intended as a limit on the scope of the invention herein.

The amount of adhesion required between the printable substrate and the magnetic composition will vary depending on application, and on the printable substrate  
15 employed. It may be desirable that the magnetic composition have sufficient adhesion to remove fiber from the printable substrate if it is, for instance, paper. Lack of fiber transfer may not always be indicative of poor adhesion however. For instance, a lack of delamination may be adequate as well. For other types of substrates such as fabrics, plastics or metallic substrates it may be desirable that the magnetic layer and printable  
20 substrate layer do not pull apart easily, or do not delaminate.

Bond strength between the magnetic layer and the printable substrate may be tested using 180° or 90° peels for instance, as is known in the art. Such methods may be found under the ASTM testing methods. The amount of force required to peel the substrates apart will vary depending on the end use and the printable substrate. For some  
25 applications a peel force of about 200 to 400 g/inch is adequate and 400 to 450 g/inch an upper limit, while for some, the peel strengths may be upwards of 1000 to 1500 g/inch or more. For instance, for thermosetting polymeric compositions, peel strengths are up to 1000 or 1500 g/inch or higher.

It is desirable that the resultant magnetic composition have little or no  
30 surface tack under ambient temperatures. The binder and mixture are very shear rate sensitive exhibiting Bingham plastic flow. In hot melt application, viscosity can be as

low as 4000 cps at 300 °F (about 150 °C) or as high as 200,000 cps at 300 °F (about 150 °C). Because temperature is a significant factor, it is not uncommon for extrusion coating to occur at temperatures of as high as about 600 °F to about 650 °F (about 315 °C to about 345 °C) melt temperatures.

5           The temperature at which the magnetic composition is applied to the substrate may be quite different from the temperature inside the extruder. The magnetic composition after exiting the extruder and the application head, and thus after formation, i.e. shaping, of the magnetic layer, may have cooled to a substantial degree at the time of application of the now formed magnetic layer to the printable substrate layer. However,  
10 the magnetic composition should remain at an elevated temperature high enough to achieve an adequate bond between the magnetic layer and the printable substrate layer.

          The magnetic material and the thermoplastic binder and/or other ingredients are blended at elevated temperatures using standard thermoplastic mixing equipment such as extruders, Baker Perkins, Banbury mixers, single or twin screw  
15 extruders, Farrell Continuous mixers, and high shear mixing equipment.

          The mixture may be compounded and made into a form, such as slats, pellets or any form known in the art suitable for feedstock for extrusion or other melt processing equipment, which is then delivered to the coating company. The coating company may then use a high pressure single screw extruder, or other processing  
20 equipment to melt and pressurize the mixture, to force it through an application head such as a slot die, rotary screen head, or other such application head, at the coating station. Thus, the extruder or other hot melt equipment supplies the resultant magnetic composition directly to the application head. During extrusion or other melt processing of the magnetic composition, the temperature may be high enough that the composition is  
25 considered to be molten, i.e. in melted or liquid form.

          In an alternative embodiment of the present invention, various ingredients may be supplied to the extruder in individual pellets, slats, and so forth. For instance, if more than one thermoplastic binder material is employed, they do not have to be supplied as a mixture already in pellet or slat form. They may each be supplied in pellet or slat  
30 form individually, for example.

          Coating companies can use a variety of application processes known in



the art. Examples of application processes useful in applying the magnetic composition to the printable substrate include, but are not limited to, slot die coating, roll coating or reverse roll coating, knife-over-roll gravure and reverse direct gravure, wire rod coating, air-knife coating, slot-orifice coating, screen printing with a hot screen, and so forth.

5           In one embodiment of the present invention, slot die coating is used in combination with a single screw extruder.

          In another embodiment of the present invention, a method referred to in the industry as flex o press is employed. The term "flex-o-press" as used herein, generally refers to a four roll coating method by which a first roll which is heated, and  
10 typically turns at a speed which is half of the second roll. The second roll carries the thermoplastic/magnetic mixture. A third roll is a roll-plate roll which is a silicone rubberized roll and may have a patterned surface with raised areas for application of the magnetic composition of the present invention to the printable substrate in a predetermined pattern. This roll comes into light contact with the second roll and then  
15 transfers the thermoplastic/magnetic mixture to a fourth roll. See Roll Coating by R. T. Schorenberg, Modern Plastic Encyclopedia, 1984-1985, pp. 202-203. Another useful reference is *Coatings Technology Handbook*, 2nd Edition, Satas and Tracton, Marcel Dekker, Inc., 2001. Desirably, the processing equipment includes a chill roll for increasing the speed with which the resultant magnetic composition, including at least the  
20 magnetic material and a thermoplastic binder, cools and sets. This is advantageous for more rapidly processing the resultant composition into rolls or sheets, for instance.

          Line speeds may vary anywhere up to 500 feet per minute or higher. Previous methods, in contrast, allowed line speeds of only about 40-80 feet per minute. The present invention thus allows line speeds that are much faster than currently used  
25 methods. The line speed may be limited by the capacity of the extruder or other application equipment employed in the present method, as well as by the type and size of the die, nozzle, or other application head employed, the pressure used, the viscosity of the magnetic composition, and the temperature of application as is known to those of ordinary skill in the art.

Any method which allows the direct application of the thermoplastic, magnetic composition at an elevated temperature when it is in a pliable or when it is in its plastic form to the printable substrate may be employed herein. Using the method of the present invention, the magnetic thermoplastic composition is directly adhered to the  
5 desired substrate in any desired shape or form without the need for an additional adhesive layer. Thus, the resultant magnetic layer is both formed and joined to the printable substrate layer in a unitary or single process.

Previous methods, in contrast, require the formation of the magnetic layer, the cutting of the magnetic layer, and then bonding the magnetic layer to the substrate  
10 through the use of an additional adhesive layer to form the magnetic assembly which is thus done using multiple processes. The magnetic layer is supplied either in roll form, or in pre-cut form in their desired shapes as required by the purposes for which the magnetic layer is to serve and then bonded to the printable substrate layer. The present invention, in contrast, allows the formation of the entire magnetic assembly in one process. Thus,  
15 the present invention provides a more efficient process over previous methods.

Using the method of the present invention, the mixture of binder and magnetic material is applied to a printable substrate at an elevated temperature wherein the thermoplastic binder is in a pliable or plastic form. The present invention forms the magnetic composition into its final form at a temperature sufficient to provide adequate  
20 wetting and adhesion between the magnetic composition and the printable substrate. Of course, the adhesion will also depend on the binder composition selected. Some binders will provide better adhesion than others.

The substrate to which the magnetic composition may be joined using the process of the present invention may be any suitable printable substrate, including, for  
25 example, paper and paper products, pasteboard, plastic or polymeric materials, metal, release liners such as silicone release liner, textiles or fabrics, and so forth. Combinations of any of the substrates may also be employed. In some embodiments, a release liner may be employed in combination with another printable substrate, one on each side of the magnetic layer, for instance. The magnetic assembly which includes the  
30 printable substrate and the magnetic layer may then be removed from the release liner at the point of use.



The application temperature required may depend on numerous factors including the melting temperature of the thermoplastic binder, the viscosity of the resultant magnetic composition, and so forth. The melting temperature and viscosity may vary depending not only on the type of binder used, but on the various other ingredients which may be employed in the magnetic composition as described above. The higher the viscosity or melting temperature, the higher the temperature that may be required to successfully apply the magnetic composition. This of course also depends on the application equipment being employed. In general, thermoplastic materials are applied at temperatures of about 275 °F to about 375 °F (about 135 °C to about 190 °C), although some may be applied at higher or lower temperatures. For instance, very low viscosity thermoplastics may be applied at temperatures of as low as about 190 °F (about 90 °C). Some may be applied at temperatures as high as about 400 °F (about 205 °C), or higher, for instance polyamide materials are often applied at temperatures of about 400 °F. Temperatures used, can even exceed 650 °F, however. However, for most thermoplastic materials higher temperatures lead to more rapid degradation of the material. An often used application temperature range is about 325 °F to about 375 °F (about 160 °C to about 190 °C), with 350 °F (about 175 °C) being very common. In one embodiment of the present invention, polypropylene is used and may be applied at temperatures of over 400 °F (205 °C). Yet, using extrusion techniques polyethylene is commonly extruded at above 600 °F (306°C) at high speeds.

The temperature should be sufficient to lower the viscosity of the thermoplastic material to allow the thermoplastic material to sufficiently adhere to the printable substrate. This may involve penetration into, or "wet out" of the substrate surface to which it is being applied. The thermoplastic material must be sufficiently adhered to the substrate so that delamination from the substrates does not occur.

Using the method of the present invention, the resultant magnetic composition may be advantageously applied in a thin layer of about 0.002 inches to about 0.030 inches (about 50  $\mu$  to about 765  $\mu$ ; about 2 mils to about 30 mils), suitably about 0.002 inches to about 0.020 inches (about 50  $\mu$  to about 510  $\mu$ ; about 2 mils to about 20 mils) and most suitably about 0.002 inches to about 0.012 inches (about 50  $\mu$  to about 305  $\mu$ ; about 2 mils to about 12 mils) thick. The present invention allows for application

of a thinner layer of the binder/magnetic mixture. Previous extrusion and calendering methods, in contrast, did not allow for magnetic layers of less than about 4 mils to about 8 mils, and often more than 10 mils.

In one embodiment of the present invention, a ribbon of the magnetic composition is applied at an elevated temperature in a plastic state to a printable substrate. The ribbon may be applied to the substrate so that it is dimensionally coextensive with the printable substrate, i.e. the same length and width, or it may be applied to the substrate in discrete, preselected areas only. Furthermore, several ribbons may be applied to the substrate simultaneously, and they may be applied intermittently in a discontinuous pattern. The application line may be equipped such that pressure is applied to the ribbon(s) to press the ribbon(s) into the printable substrate. For instance, a chill roll may be employed for this purpose.

The surface of the ribbon may also be contacted by a magnetizing roll which smooths, cools and magnetizes the ribbon(s). When this is done while the ribbon is still fluid, it provides an enhanced magnetic effect known as alignment. The ribbon may be applied at a thickness of between about 0.002 inches and to about 0.020 inches (about 50  $\mu$  to about 510  $\mu$ ).

In broad terms, the method of the present invention allows the magnetic composition to be formed and applied directly to the printable substrate in a single, unitary process. The width, thickness and length of the magnetic layer may be individually tailored to any desired size, and may be designed to cover all of the printable substrate being therefore applied generally dimensionally coextensive with the printable substrate, or may be applied to cover only some discrete portion of the substrate. Furthermore, it may be applied in a patterned form such as by using the silicone rubberized roll as described above (e.g. flexopress).

Furthermore, the magnetic composition may be formed and affixed to the printable substrate in a finished form substantially simultaneously. The thickness and width, or the thickness, width and length may be in their final fixed form. As used herein, the term "substantially simultaneously" may be used to indicate that it is occurring during a single process of manufacture.

The magnetic composition may be fully magnetized during the



manufacturing process by providing a magnetic field on the line the entire width of the web after application of the magnetic composition to the printable substrate. The magnetization step may be optionally included after printing, or after formation of the article to its desirable size and shape by cutting, stamping or punching as described  
5 below.

In addition, the magnetizing step may be carried out while the thermoplastic binder is at an elevated temperature. This results in an alignment of the magnetic particles with a significant increase in the magnetic strength of the article as compared to the same article magnetized at ambient temperature. See U.S. Pat. Nos.  
10 4022701 (Sawa), and 6190573 (Ito).

Optionally, indicia, i.e. printed matter, may be applied to the printable substrate prior to joining with the magnetic layer, or it may be printed after it has been joined with the magnetic layer. For ease of production, it may be desirable to print after the magnetic material has been joined to the printable substrate. However, no print need  
15 be applied to the printable substrate. For instance, in the case of magnetic note pads, no print may be applied. This allows the end user to apply their own notes and reminders to individual sheets of paper.

Once printed matter has been applied to the printable substrate, lacquers, films or other protective surfaces which also improve the appearance of the now printed  
20 substrate, may be provided on the surface of the printed substrate. These or similar materials may also be applied to the exposed surface of the magnetized layer to prevent unintended sticking or "blocking" of the combined article to itself or other substrates if necessary.

Once the entire magnetic assembly has been produced in roll or sheet  
25 form, the desired shapes may be cut, punched, stamped, or so forth from the assembly, either at the point of manufacture of the magnetic material, or by those to which the magnetic assembly is supplied as desired. Laser cutting is one example of a method by which various articles may be formed from the sheet or web.

Fig. 1 illustrates generally at 10, a magnetic assembly as produced using  
30 the process of the present invention. Magnetic layer 12 is joined to a printable substrate layer 14 without the use of an additional adhesive layer.

Fig. 2 illustrates generally at 10, one embodiment of the present invention in which the magnetic layer 14 is applied in a discrete area of the printable substrate 12.

Fig. 3 shows generally at 10, an alternative embodiment of the magnetic assembly of the present invention in which the magnetic layer 14 is shown substantially  
5 coextensive with the printable substrate layer 12 both in length 16 and width 18.

In one particular embodiment of the present invention, the magnetic assembly is a magnetic label assembly. The magnetic label assembly is a magnetic label assembly which includes the magnetic layer 14 and the printable substrate layer 12 having the desirable indicia or information printed thereon.

10 Fig. 4a illustrates generally at 10 a magnetic label assembly of the present invention with the printable substrate layer 12 joined to a magnetic layer 14. The magnetic layer is further attached to a release liner 26. Release liners include those substrates which include silicones, among others. This may be accomplished using any means known in the art such as through the use of a removable pressure sensitive  
15 adhesive, such as a removable hot melt adhesive, or dry release adhesive, although in some embodiments, no adhesive may be required. Furthermore, the entire assembly of printable substrate layer 12, magnetic layer 14 and release liner 26 may be further adhered to an article such as a package, cup, book, magazine or other such article 22 through the use of a pressure sensitive or dry release adhesive (not shown). The  
20 magnetic assembly 10 may then be used in commerce for advertising or promotional purposes.

In one particular embodiment, the magnetic assembly is a magnetic label assembly. The magnetic label assembly is releasably adhered by any adhesive known to those of skill in the art including water based adhesives and hot melt adhesives, as well  
25 as others to the base article. Suitably, the adhesive is a pressure sensitive adhesive, and even more suitably, a removable pressure sensitive adhesive, although the pressure sensitive adhesives employed may also be of the permanent or semi-permanent type as well. Release liners are by their nature difficult to adhere so the type of adhesive employed is not limited. Therefore, depending on the release liner employed,  
30 semi-permanent and permanent adhesives may also be employed, as well as non-pressure sensitive adhesive. The selection of adhesives is known to those of skill in the art.



However, in any event, it is desirable that the adhesive form a stronger bond with the base article, than with the release liner to allow easy removal of the magnetic assembly from the base article. Once the magnetic assembly is removed, it may then be placed on a magnetic surface such as a refrigerator, cabinet, magnetic bulletin board or notice board, and so forth for the purposes of displaying the printed indicia thereon.

One example of an adhesive suitable for use herein includes an ethylene-vinyl acetate copolymer latex, and even more specifically, an aqueous dispersion containing 60% solids by weight including 22.4 wt-% ethylene and 77.6 wt-% vinyl acetate. The adhesive may optionally include a crosslinking agent and/or an inorganic peroxide among other optional ingredients known to those of skill in the art.

The base article may be formed from any desired material and can have any structure to which the magnetic label assembly may be releasably adhered. In the above example, the adhesive is therefore between the release liner and the base article.

Fig. 4b shows an alternative embodiment in which the printable substrate layer 12 further has an overlamine 28 which extends over the printable substrate layer 12 which is dimensionally substantially equivalent in at least length and width to the magnetic layer (not shown). The overlamine is preferably a clear polymeric film material. In this embodiment, no adhesive is required between the magnetic layer and the release liner or the release liner and the article 22. The overlamine has perforations which are substantially dimensionally equivalent in length and width to the printable substrate layer 12 and the magnetic layer (not shown) for easy removal of the magnetic assembly which includes the printable substrate layer and the magnetic layer. Any number of perforations may be employed. Desirably, at least two perforations on opposing sides of the assembly are desirable. Embodiments such as these are further discussed in relation to figs. 11-13 described in detail below.

Optionally, the overlamine may have substantially the same length, but a slightly larger width, or in the alternative, the substantially same width, but a different length. All sides of the overlamine, or two opposing sides of the overlamine can be secured to a base article through the use of an adhesive, for example. The adhesive may be applied in thin strips, dots, or other patterns known to those of skill in the art. The adhesive may be either removable, permanent or semi-permanent as well as pressure

sensitive or non-pressure sensitive. Suitably, the adhesive is a permanent adhesive. The type of adhesive selected, however, is strictly a preference based on the user. The main consideration is that the magnetic assembly be removable from the overlamine as well as from the base article. This may be done, for example, through the use of perforations,  
5 wherein part of the overlamine remains with the base article, and part remains with the magnetic assembly. If perforations are employed, it may be desirable to place the perforations just inside of the adhesive.

The magnetic assembly may then be removed from the base article by breaking the perforations. In the particular embodiment described above in which an  
10 overlamine is employed, the magnetic assembly may be removably adhered to the release liner through the use of an adhesive, but no adhesive is required because the overlamine secures the magnetic assembly to the base article. Once removed, the magnetic assembly may be self-adhered to a magnetic surface such as a refrigerator, cabinet, magnetic bulletin or notice board, and so forth.

15 An optional embodiment may have the magnetic assembly 10 packaged in a thin film for instance, such as a polyolefin or polyolefin copolymer based film, saran, mylar, or some such film. An application similar to this is referred to in the bookbinding industry or pressure sensitive adhesive industry as magazine tipping wherein advertisements or samples are temporarily adhered to a magazine or book. Once  
20 removed from the package, book, magazine or so forth, the magnetic assembly 10 may be self adhered to a magnetic surface such as a refrigerator or filing cabinet, for instance.

Fig. 5 illustrates generally at 15 a magnetic assembly of the present invention prior to forming the individual pieces from the sheet or web in which the magnetic layer 14 is shown substantially coextensive in length 16 and width 18 with the  
25 printable substrate layer 12. In this embodiment, individual pieces such as labels, business cards, and so forth, for example, have been printed on printable substrate layer 12 (print not shown) in a sheet form. The individual magnetic pieces 24 may then be later cut, stamped, punched and so forth out of the sheet at the perforations 26 forming individual magnetic pieces 24.

30 Fig. 6 illustrates an alternative embodiment of that shown in Fig. 5 in which the magnetic layer 14 has been applied in ribbons and pressed in discrete areas



only on the printable substrate layer 12. In this embodiment, a strip of magnetic layer 14 is shown at the top of what will be each individual piece 24 when cut at the perforations 26.

Optionally, the individual pieces may be bound together in a process similar to what is referred to in the industry as "perfect" binding. Using this process, the individual pieces or sheets of printable substrate having the magnetic layer are stacked in a block or arranged in a pad format, held in a clamp to form a block, and then bound together using an adhesive. The adhesive is applied to one side of the stack or pad, which also may be referred to as the "backbone" of the block. A cover may be adhered to the backbone to prevent the adhesive from adhering in the case of a pressure sensitive adhesive. If a non-pressure sensitive adhesive is employed, and it is not tacky, then no cover may be necessary. The adhesive may be applied by spraying, rolling or any other means known in the art. An alternative to employing an adhesive is to stack the individual magnetic pieces in a stack, block or pad, and then shrink wrapping them together. Fig. 7 illustrates generally at 20, a stack or block of individual magnetic assemblies 10. Fig. 8, 9 and 10 illustrate various embodiments in which magnetic layer 14 is applied to the printable substrate 12, in this embodiment, blank paper. Of course, the paper can be personalized, or have messages printed on it, and so forth.

Fig. 11 illustrates generally at 50 a cross-sectional view of an alternative embodiment of the magnetic assembly produced according to the present invention. Magnetic layer 14 is joined to printable substrate layer 12 without the use of an additional adhesive layer. Magnetic layer 14 a release liner 26 is employed in combination with and next to the magnetic layer 14. In this instance, an overlamine 28 is employed to hold the assembly together. Overlamine 28 has perforations 30 which may be employed to remove the magnetic assembly 10 which includes the printable substrate layer 12 and the magnetic layer 14, from the release liner 26. In this case, no adhesive is employed to hold the release liner 26 to the magnetic layer 14. Fig. 12 illustrates a top down view showing the perforations 30 in the overlamine 28. These can be produced in sheet form, for instance, as shown generally at 60 in fig. 13.

In one particular embodiment, the magnetic assembly as described above is a magnetic label assembly.

The assembly as shown in figs. 11-13 is a four layer structure as shown cross-sectionally in fig. 11. No adhesives are employed in this embodiment. The entire assembly includes a release liner 26, a magnetic layer 14, a printable substrate layer 12 and a clear over laminate 28.

5 Fig. 14 illustrates an alternative embodiment in which the magnetic layer 14 being applied in discreet individually sized pieces 15. This assembly is of a two-layer construction having only the printable substrate layer 12 and the magnetic layer 14. The printable substrate layer 12 has perforations 30 which coincide with each individual discreet magnetic piece 15 and allow each individual magnetic assembly 10 of the  
 10 present invention which includes the printable substrate layer 12 and the magnetic layer 14 to be easily removed from the sheet 60. The magnetic pieces 15 are directly adhered to the printable substrate layer 12. Fig. 15 illustrates a top down view of the embodiment of the magnetic sheet described in fig. 14 showing perforations 30 in the printable substrate layer 12 which coincide with the individual magnetic piece 15 so as to provide  
 15 easy removal.

The above described figures illustrate only some of the embodiments of the present invention and are intended for exemplary purposes only, and do not limit the scope of the present invention to those embodiments as described herein.

The method of the present invention wherein the magnetic composition is  
 20 applied directly to the printable substrate, allows for all of the other steps to also be included in the unitary manufacturing process of the present invention. Optionally any combination of the steps of printing, coating and formation of the article by cutting, stamping, punching, and so forth, may be included in the unitary process.

Articles which may be produced in this way, include, but are not limited  
 25 to, promotional pieces, greeting cards, postcards, business advertisements, magnetic business cards, appointment reminder cards, announcements, advertisements, coupons, labels, calendars, schedules, tourist attractions, picture frames, other informational purposes, and so forth which have a magnetic surface joined to a printable surface which may be self-adhered or self-sticking to a metallic surface for display.

30 Announcement cards may include, for instance, baby announcements, showers, weddings, anniversaries, parties, "we've moved" announcements, and so forth.



Promotional products include, for example, restaurant advertisements, auto services, veterinary clinics, real estate agents, lawn care services, insurance agents, and so on and so forth. These promotional pieces may conveniently include phone numbers and addresses. Furthermore, adding calendars to such pieces may improve the  
5 chances for use on refrigerators, for instance.

Other examples include, schedules such as schedules for athletic events, school events, and so forth. Such articles are intended for exemplary purposes only, and are not intended to limit the scope of the present invention. There are numerous uses for the magnetic assembly of the present invention, and one of ordinary skill in the art would  
10 know how to use the magnetic assembly or modifications thereof, for further articles not described herein.

The items described above may be distributed through direct mailings, through addition to magazines or newspapers, and so forth.

Alternatively, the magnetic assembly of the present invention may be  
15 employed in children's toys such as magnetic paper dolls or character figures, or for example, letters or numbers of self-adhering to magnetic bulletin boards.

The above disclosure is intended to be illustrative and not exhaustive. This description will suggest many variations and alternatives to one of ordinary skill in this art. All these alternatives and variations are intended to be included within the scope  
20 of the claims where the term "comprising" means "including, but not limited to". Those familiar with the art may recognize other equivalents to the specific embodiments described herein which equivalents are also intended to be encompassed by the claims.

Those skilled in the art may recognize other equivalents to the specific embodiments described herein which equivalents are intended to be encompassed by the claims attached hereto.

The following non-limiting examples are further illustrative of the present  
5 invention.

## EXAMPLES

### Example 1

10 Amorphous polypropylene P #1023 supplied by the Eastman Chemical Co. was mixed with HM 410 Starbond ferrite powder supplied by Hoosier Magnetics in amounts of 85 wt-% polypropylene and 15 wt-% of the ferrite powder. The resultant mixture was processed at a temperature of between about 325 °F and 375 ° F (about 165 °C to about 190 °C) and formed into ribbons using an extruder/slot die head on a  
15 printable paper substrate. The thickness of the mixture was varied between about 0.003 and 0.012 inches ( $\mu$  to  $\mu$ ).

This test was run at speeds varying between 250-500 feet per minute for coating discrete ribbons, and about 80 feet per minute for full coverage.



**THE EMBODIMENTS OF THE INVENTION IN WHICH AN EXCLUSIVE PROPERTY OR PRIVILEGE IS CLAIMED ARE DEFINED AS FOLLOWS:**

1. A method of forming a magnetic assembly having at least one magnetic layer  
5 having dimensions of thickness, width and length, and at least one printable substrate layer having dimensions of thickness, width and length, comprising the steps of:
  - a) providing a magnetic hot melt composition at a temperature between  
about 135°C and about 205°C with an extruder which is a single screw or  
double screw extruder, the magnetic hot melt composition comprising  
10 about 70 wt-% to about 95 wt-% of at least one magnetic material and about 5 wt-% to about 30 wt-% of at least one thermoplastic binder selected from polyolefins and copolymers thereof;
  - b) applying said magnetic hot melt composition with a slot die head at an  
elevated temperature when it is pliable to a printable substrate layer to  
15 form a magnetic layer having a thickness of about 50  $\mu$  to about 765  $\mu$  to form the magnetic assembly.
2. The method of claim 1 wherein said magnetic layer is applied at a thickness of about 50  $\mu$  to about 510  $\mu$ .
3. The method of claim 1 wherein said magnetic substrate layer is applied at a  
20 thickness of about 50  $\mu$  to about 305  $\mu$ .
4. The method of claim 1 wherein said printable substrate layer is formed of paper, paper products, or paste board.

5. The method of claim 1 wherein said magnetic hot melt composition is provided with a single screw extruder.
6. The method of claim 1 wherein said magnetic hot melt composition is applied at a temperature between about 135°C and about 190°C.
- 5 7. The method of claim 1 wherein said magnetic hot melt composition comprises about 80 wt-% to about 95 wt-% of said at least one magnetic material and about 5 wt-% to about 20 wt-% of said at least one thermoplastic binder.
8. The method of claim 1 wherein said magnetic hot melt composition comprises about 85 wt-% to about 95 wt-% of said at least one magnetic material and about 5 wt-%  
10 to about 15 wt-% of said at least one thermoplastic binder.
9. The method of claim 1 wherein said at least one thermoplastic binder comprises a copolymer of ethylene.
10. The method of claim 9 wherein said at least one thermoplastic binder is selected from the group consisting of copolymers of ethylene and at least one of vinyl acetate,  
15 n-butyl acrylate (EnBA), methyl (meth) acrylates, ethyl (meth) acrylates, interpolymers of ethylene with at least one C<sub>3</sub> to C<sub>20</sub> alphaolefin, propylene, butylene and mixtures thereof.
11. The method of claim 9 wherein said at least one thermoplastic binder is selected from copolymers of ethylene and vinyl acetate.
- 20 12. The method of claim 1 further comprising the step of applying an adhesion promoting layer to said printable substrate layer before step b).
13. The method of claim 1 wherein said magnetic hot melt composition is provided



in pellet form.

14. The method of claim 1 further comprising the step of subjecting said magnetic assembly to a strong magnetic field sufficient to result in a permanent magnetic effect in the assembly.

5 15. The method of claim 1 further comprising the step of printing said printable substrate layer.

16. A note pad, the note pad comprising a plurality of sheet articles, each sheet article comprising:

at least one printable substrate layer which is paper; and

10 at least one magnetic layer disposed on the at least one printable substrate layer, the magnetic layer comprising a magnetic hot melt composition, the magnetic hot melt composition comprising about 75 wt-% to about 95 wt-% of a magnetic material and about 5 wt-% to about 25 wt-% of a thermoplastic hot binder, the magnetic layer has equivalent dimensions of length and width to said substrate layer; and

15 wherein the sheet articles are stacked into a pad and bound at one end with an adhesive composition.

17. The note pad of claim 16 wherein said sheet articles are bound into a pad using a perfect binding wherein the adhesive is applied to an edge of the stacked sheets.

18. The note pad of claim 16 wherein said thermoplastic binder is selected from  
20 copolymers of ethylene and vinyl acetate and mixtures thereof.

19. The note pad of claim 16 wherein said magnetic hot melt composition comprises about 80 wt-% to about 95 wt-% of said at least one magnetic material and about 5 wt-%

to about 20 wt-% of said at least one thermoplastic binder.

20. The note pad of claim 16 wherein said magnetic hot melt composition comprises about 85 wt-% to about 95 wt-% of said at least one magnetic material and about 5 wt-% to about 15 wt-% of said at least one thermoplastic binder.

5 21. The note pad of claim 16 wherein said magnetic layer has a thickness of about 50  $\mu$  about 510  $\mu$  thick.

22. The note pad of claim 16 wherein said magnetic layer as a thickness of about 50  $\mu$  about 305  $\mu$ .

23. The note pad of claim 16 wherein each sheet article has a permanent magnetic  
10 effect.



1 / 11

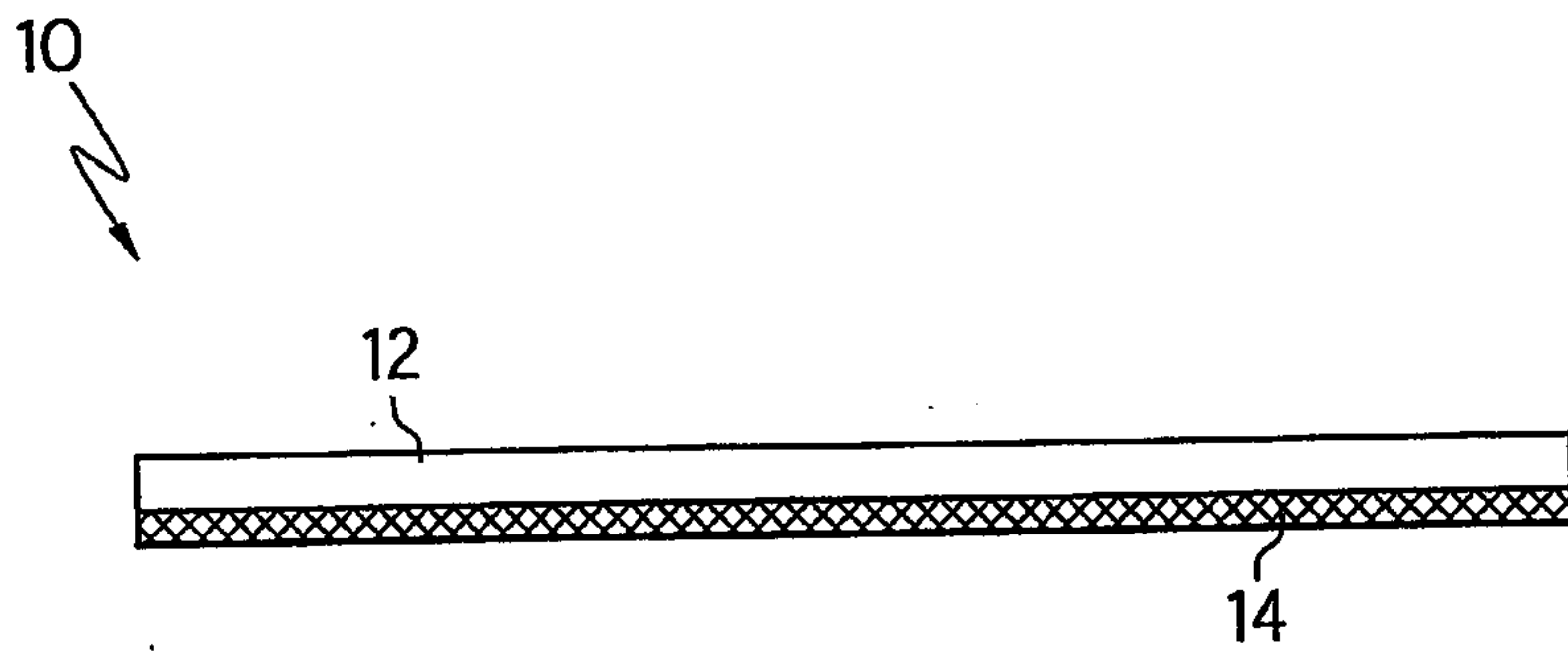

FIG. 1

2 / 11

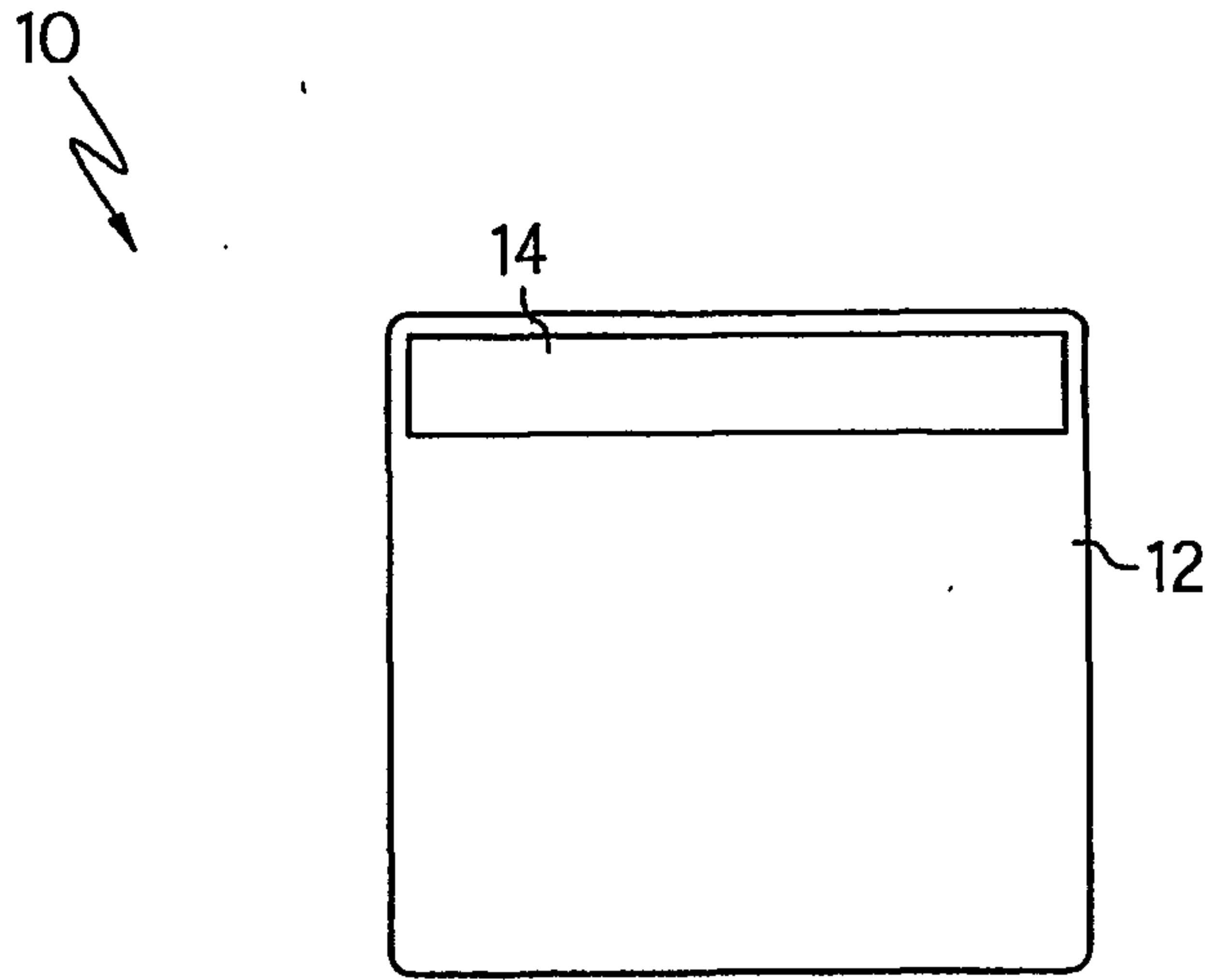

FIG. 2

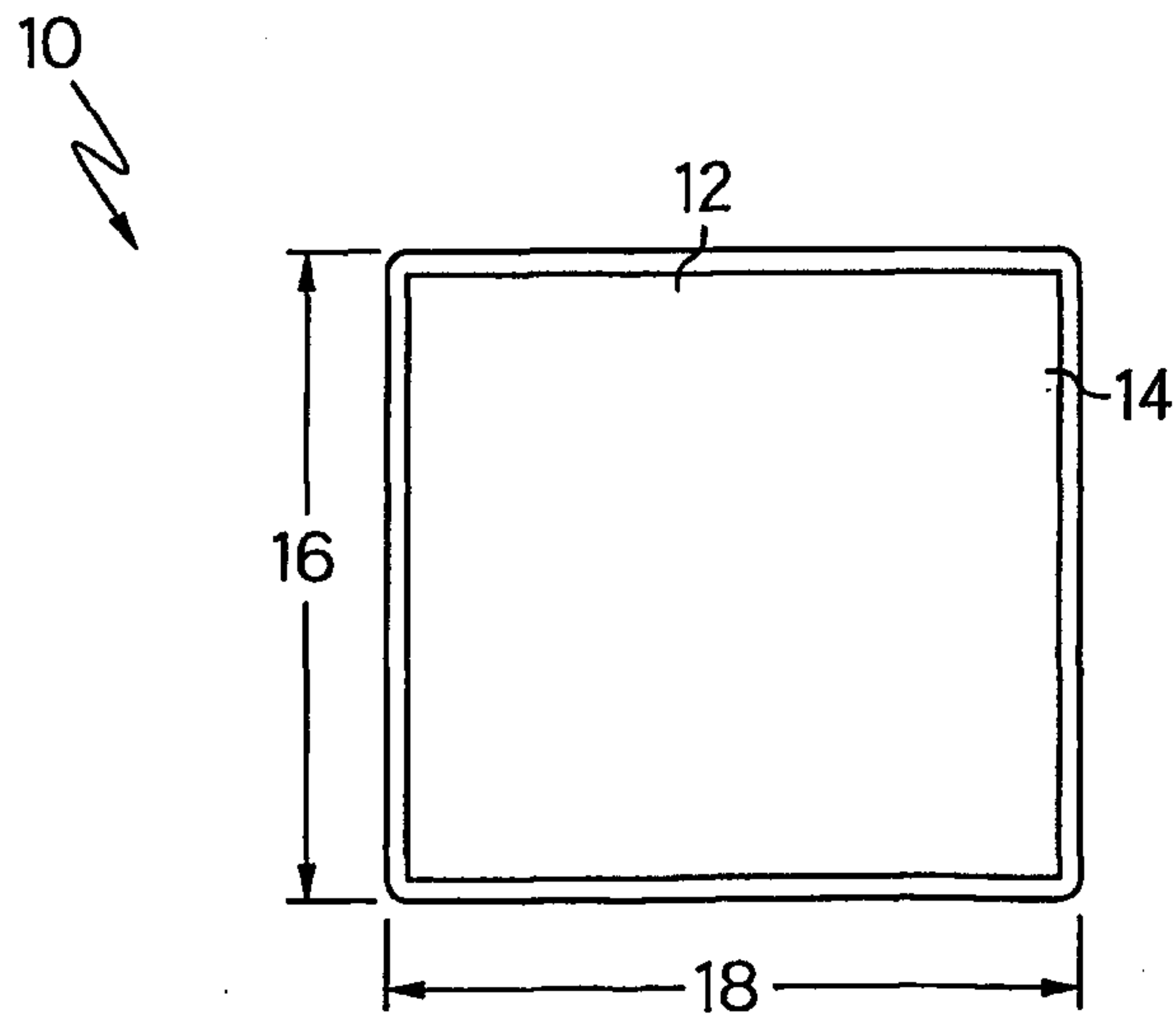

FIG. 3



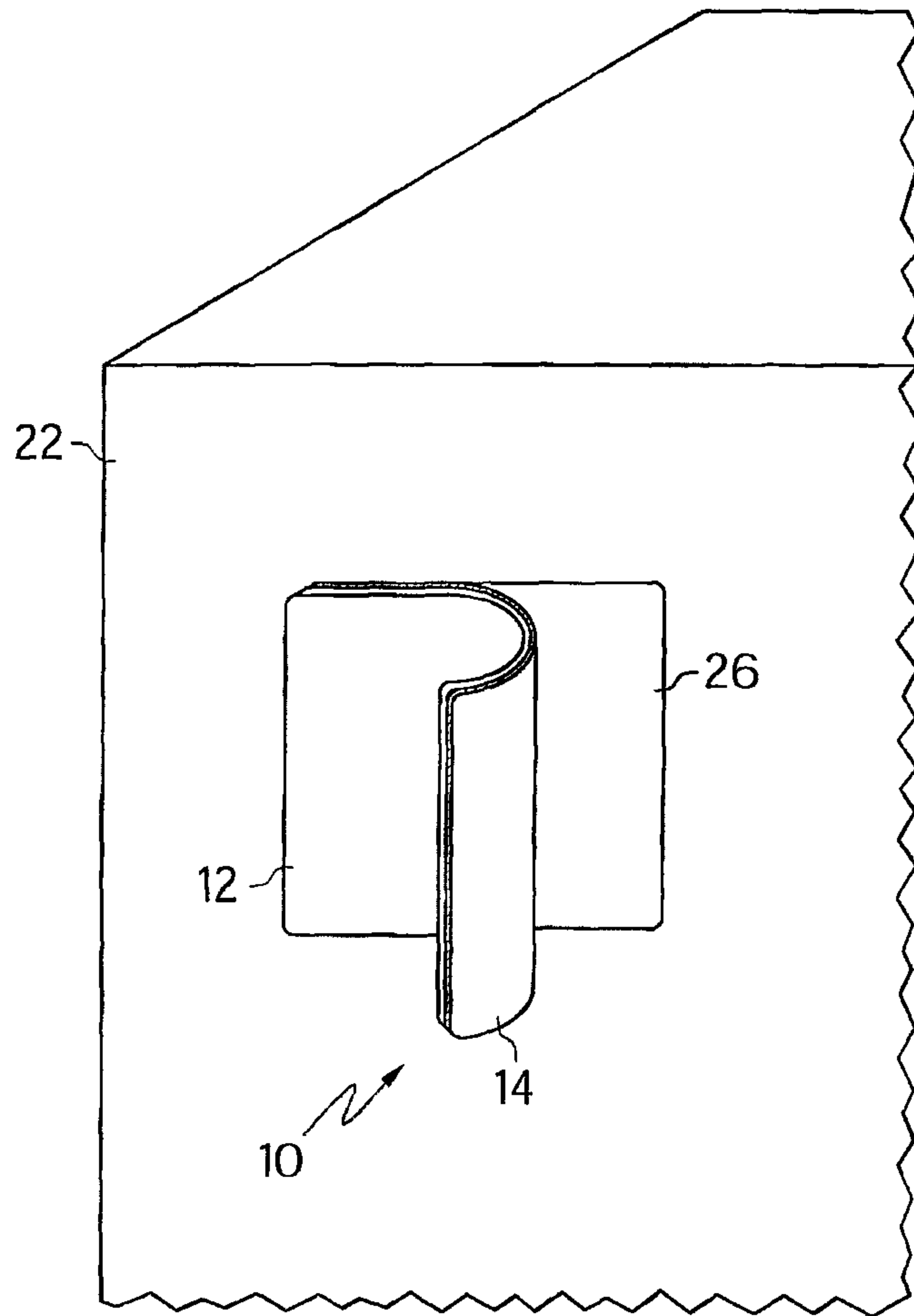

FIG. 4A

4 / 11

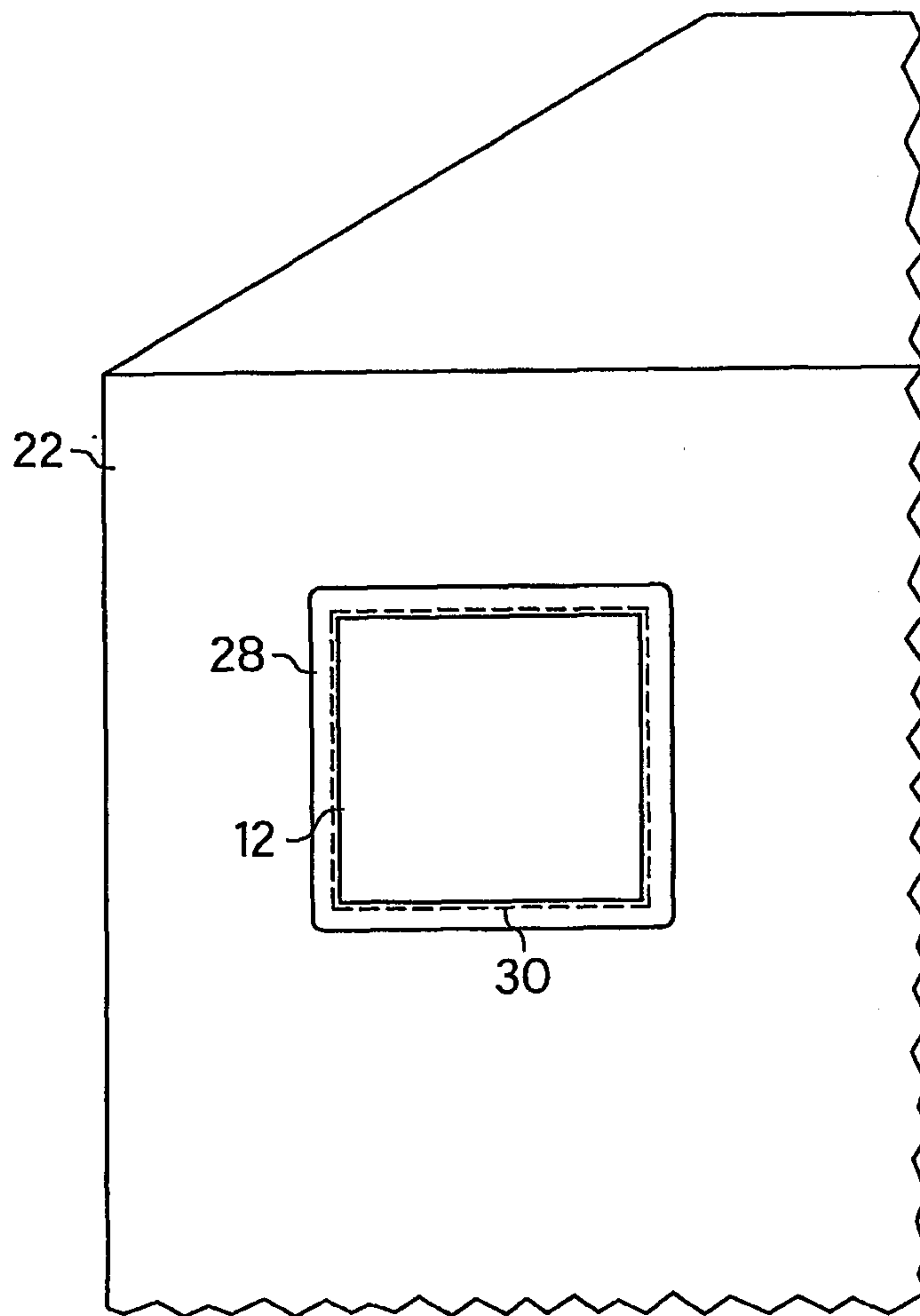

FIG. 4B



5 / 11

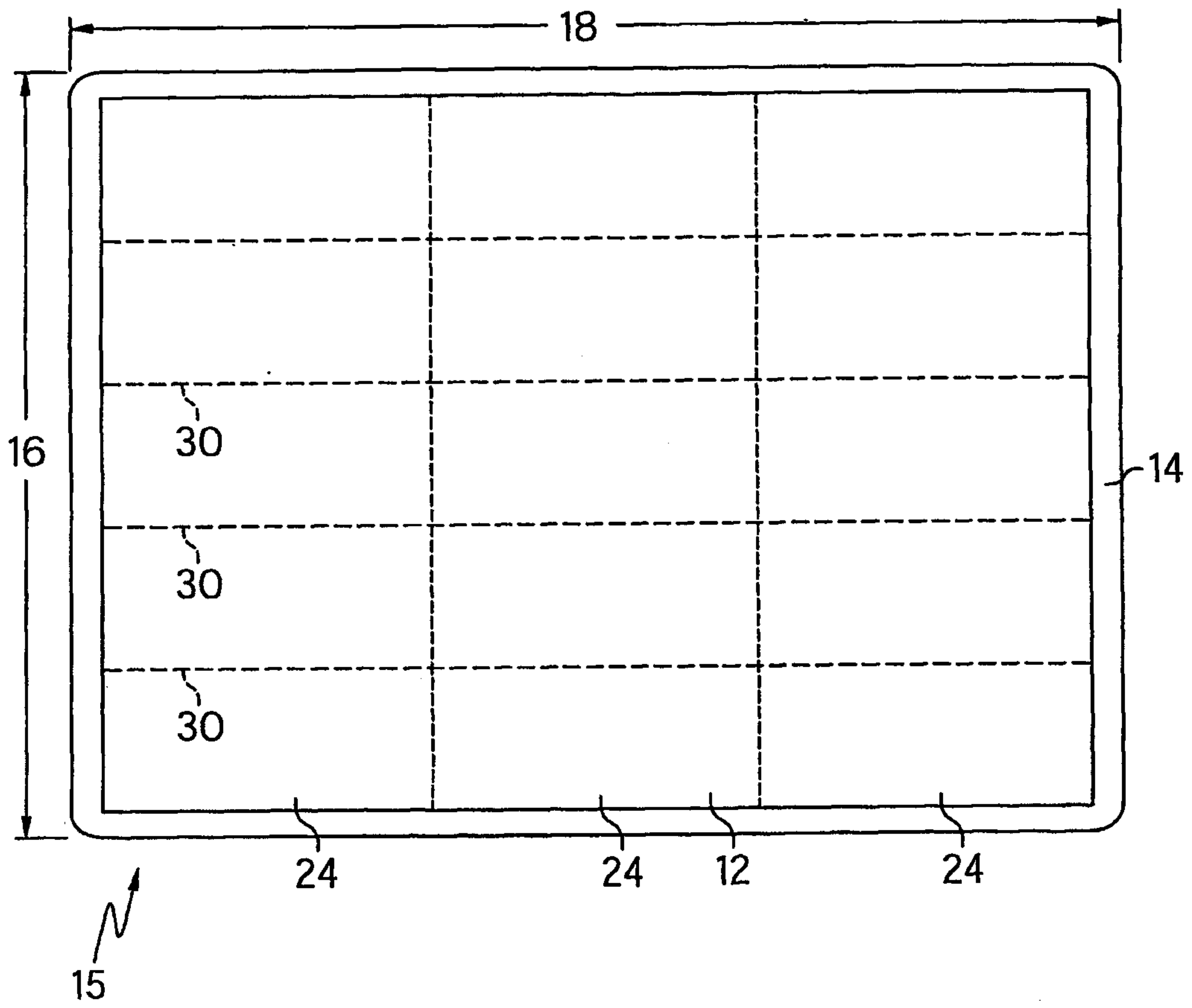

FIG. 5

6 / 11

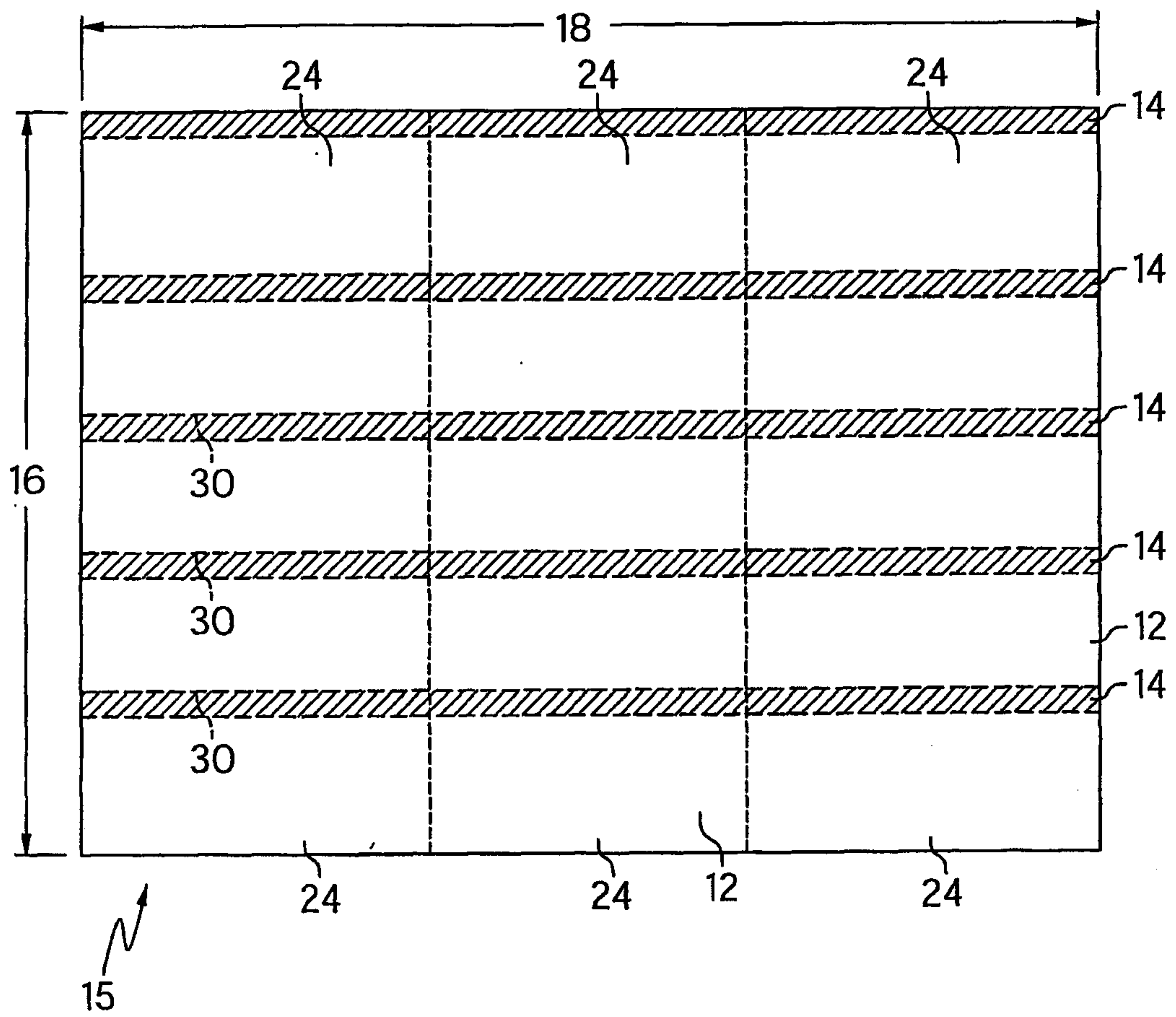

FIG. 6



7 / 11

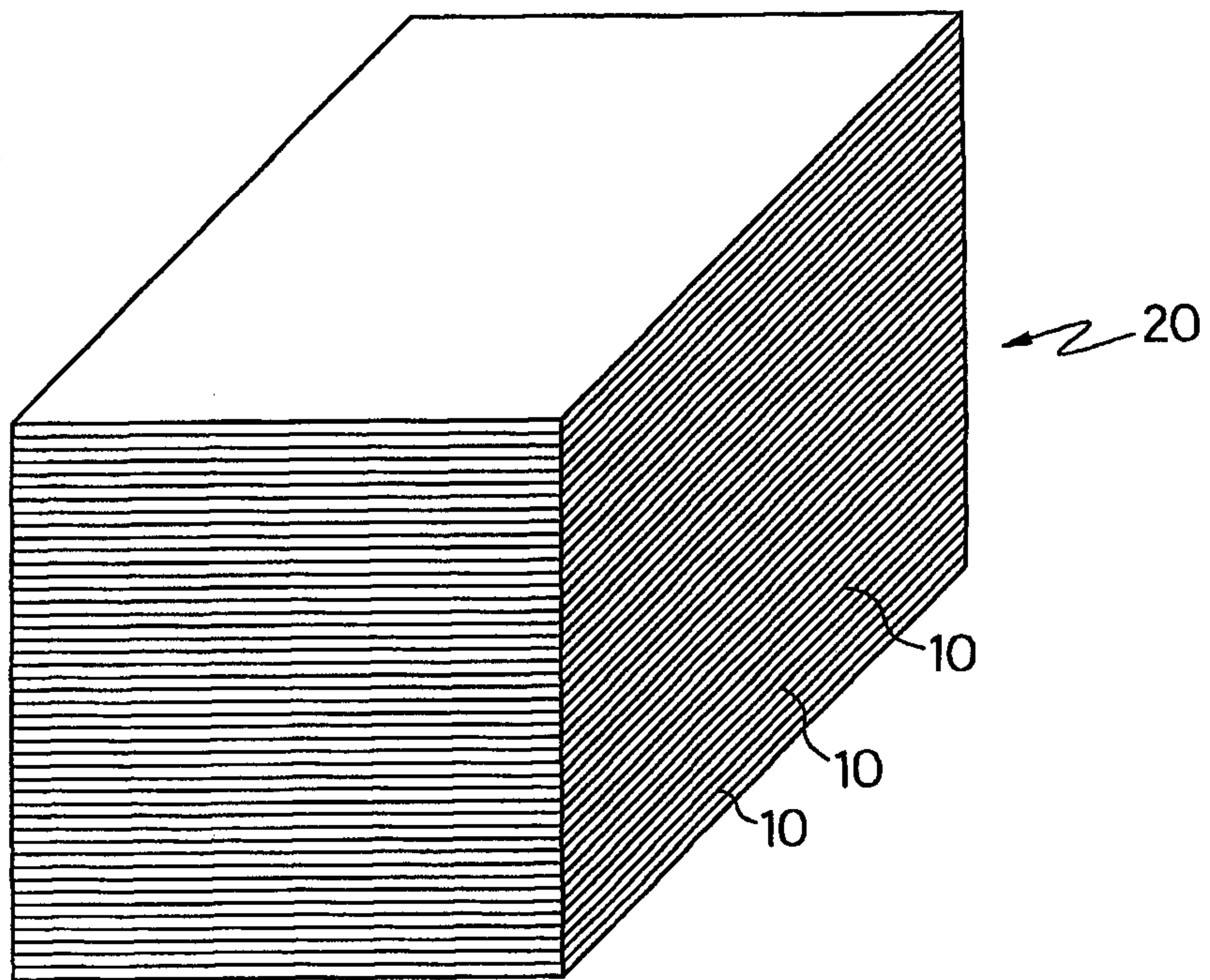

FIG. 7

8 / 11

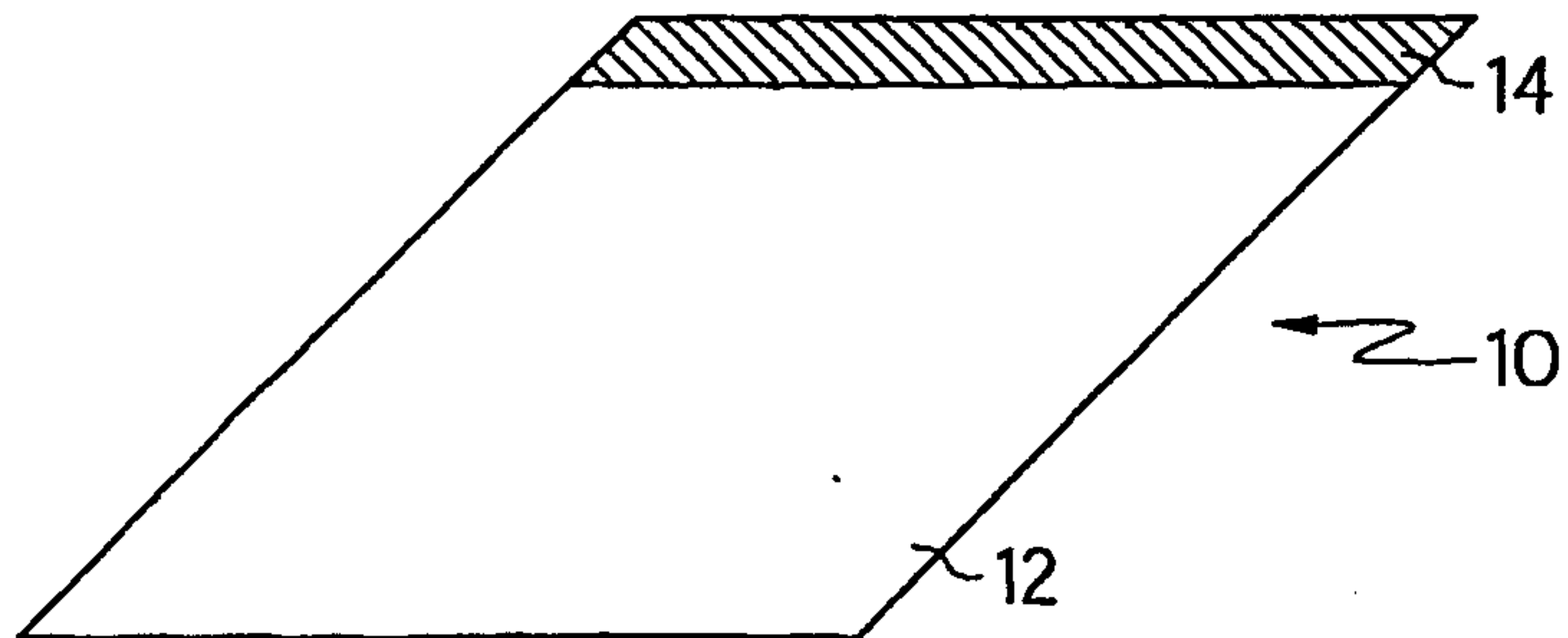

FIG. 8

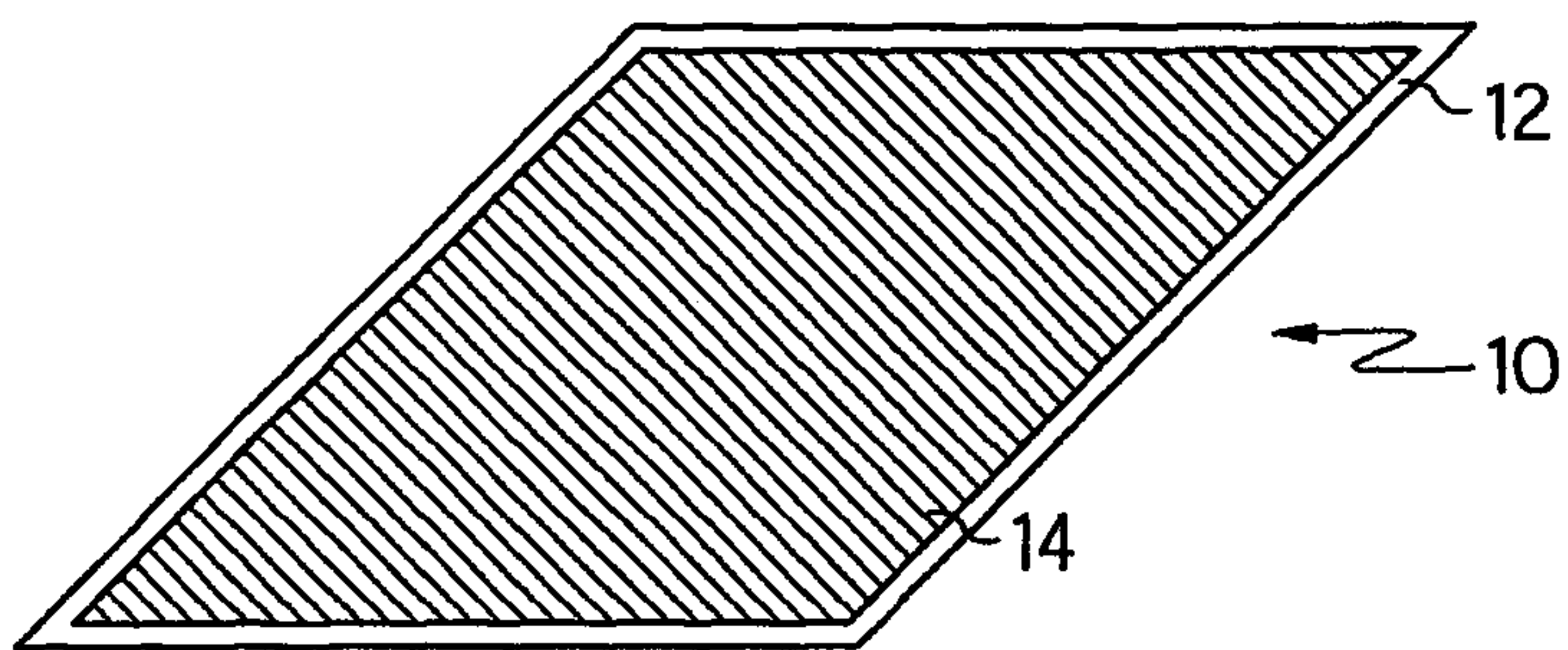

FIG. 9

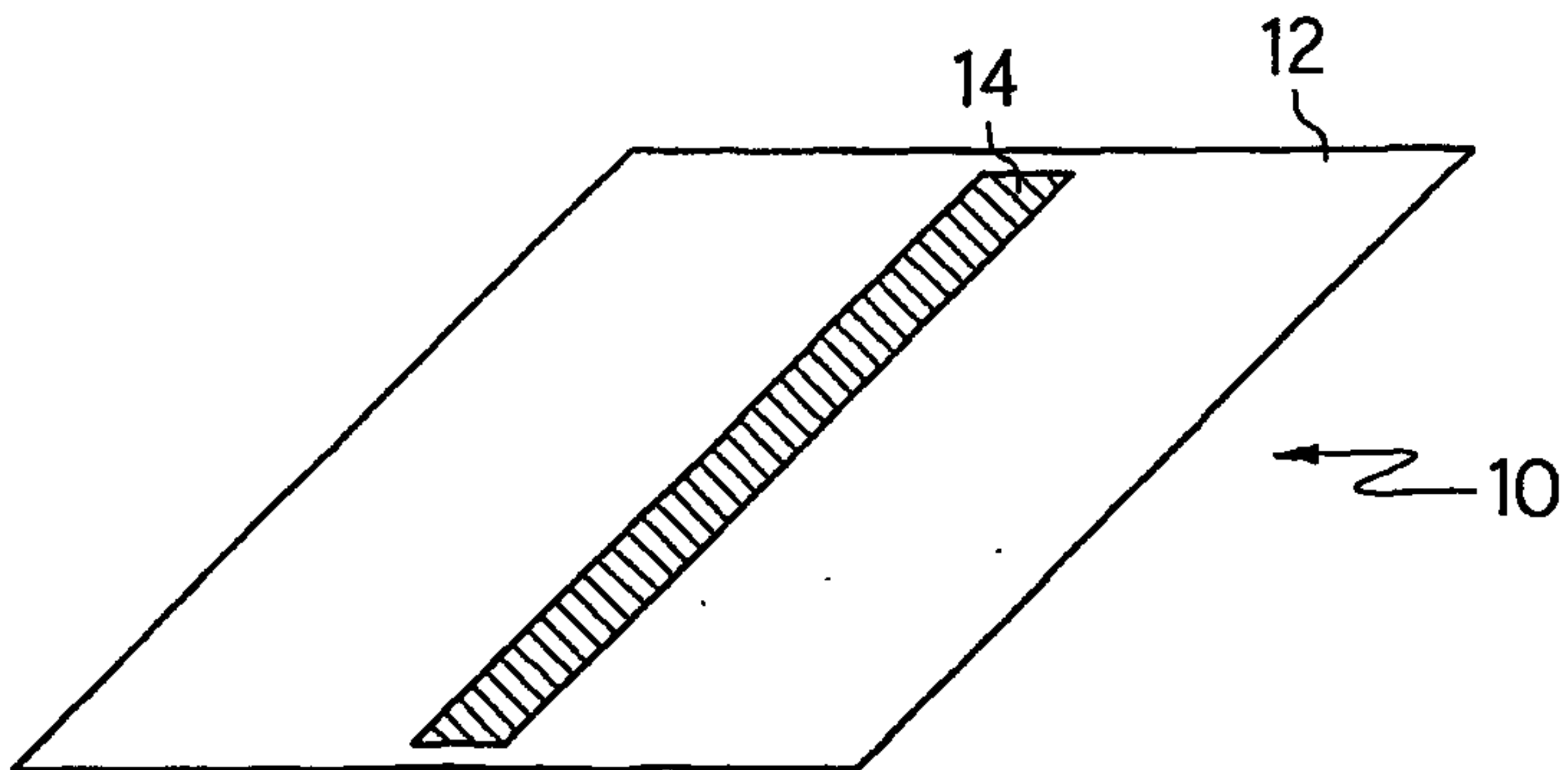

FIG. 10



9 / 11

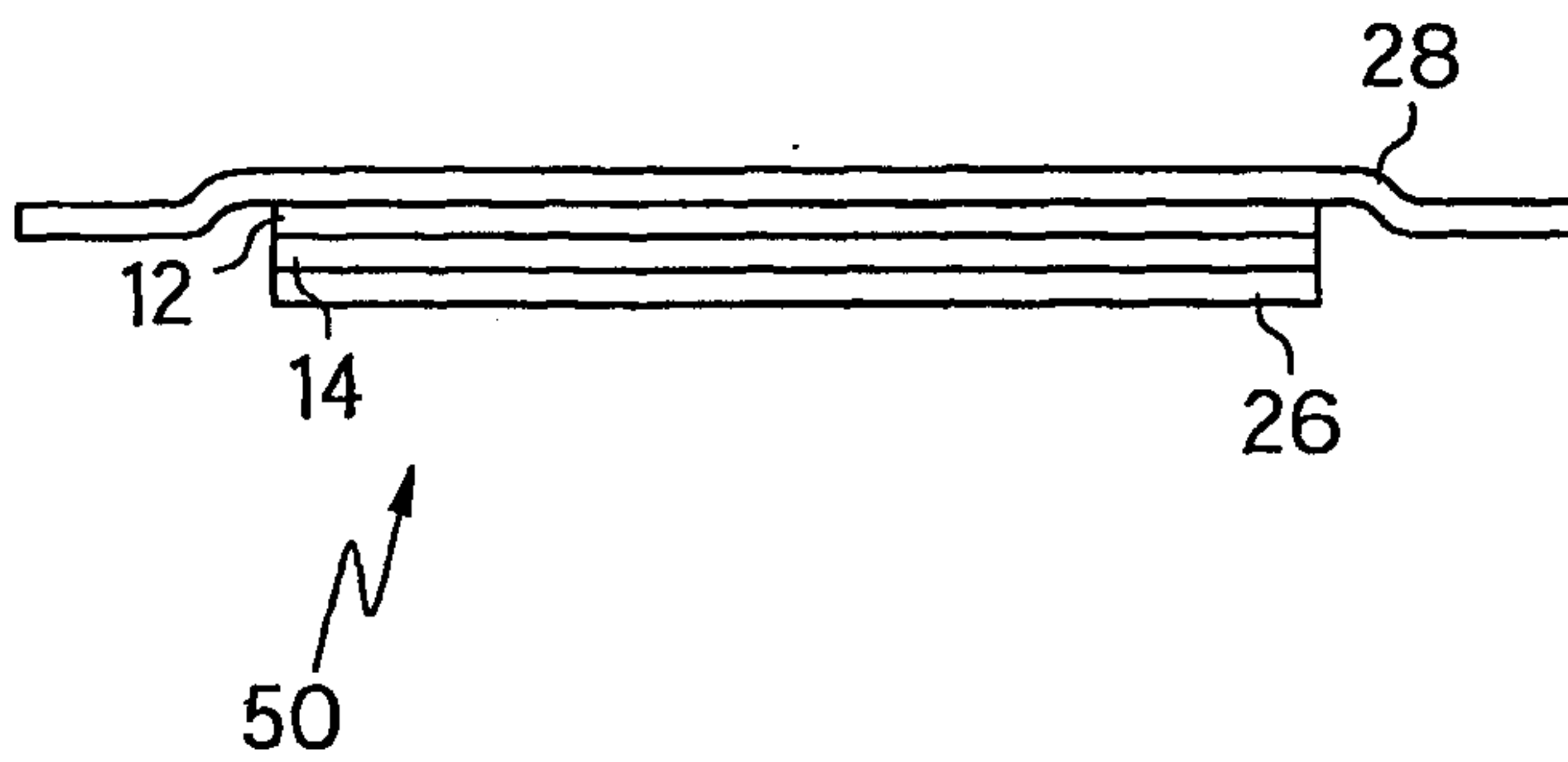

FIG. 11

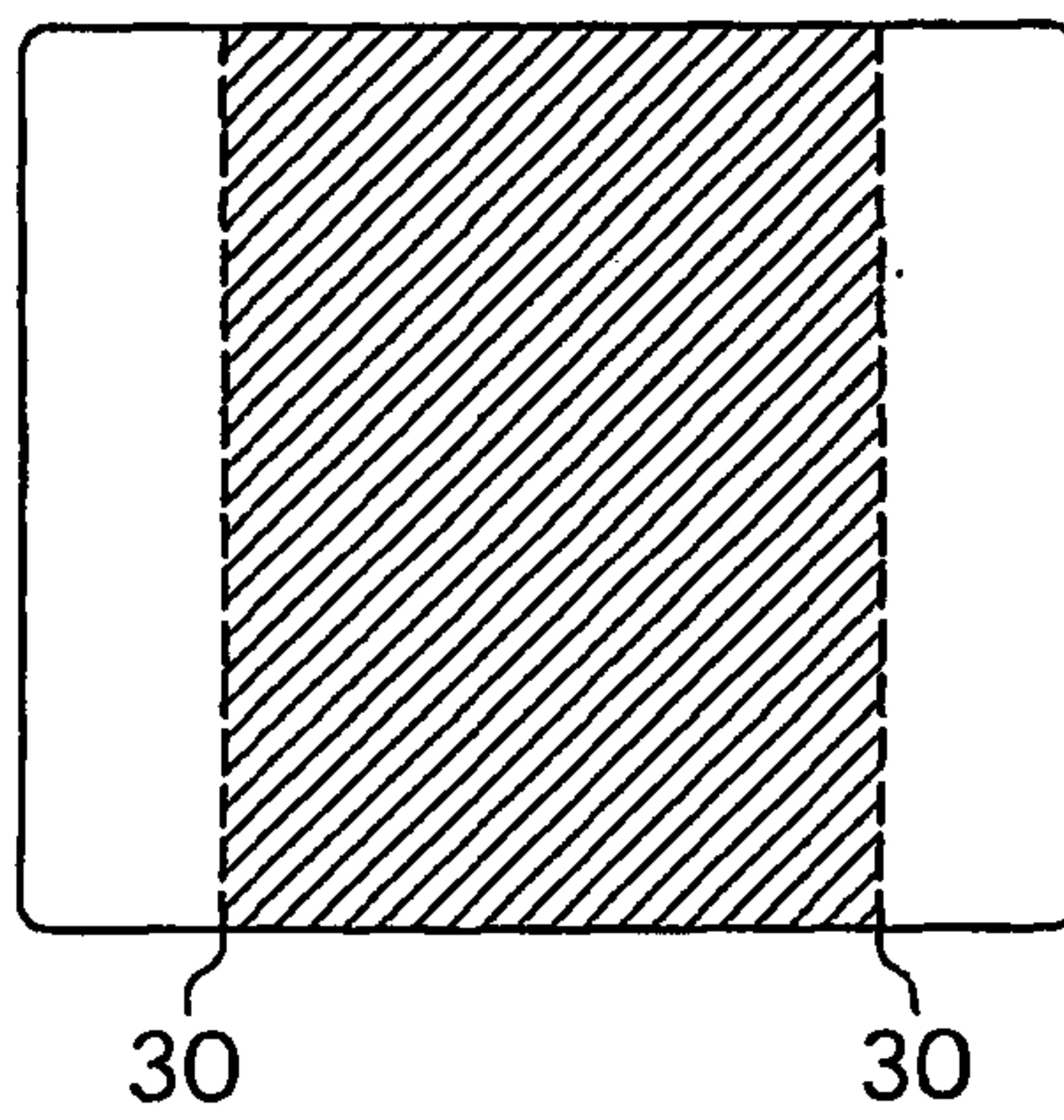

FIG. 12

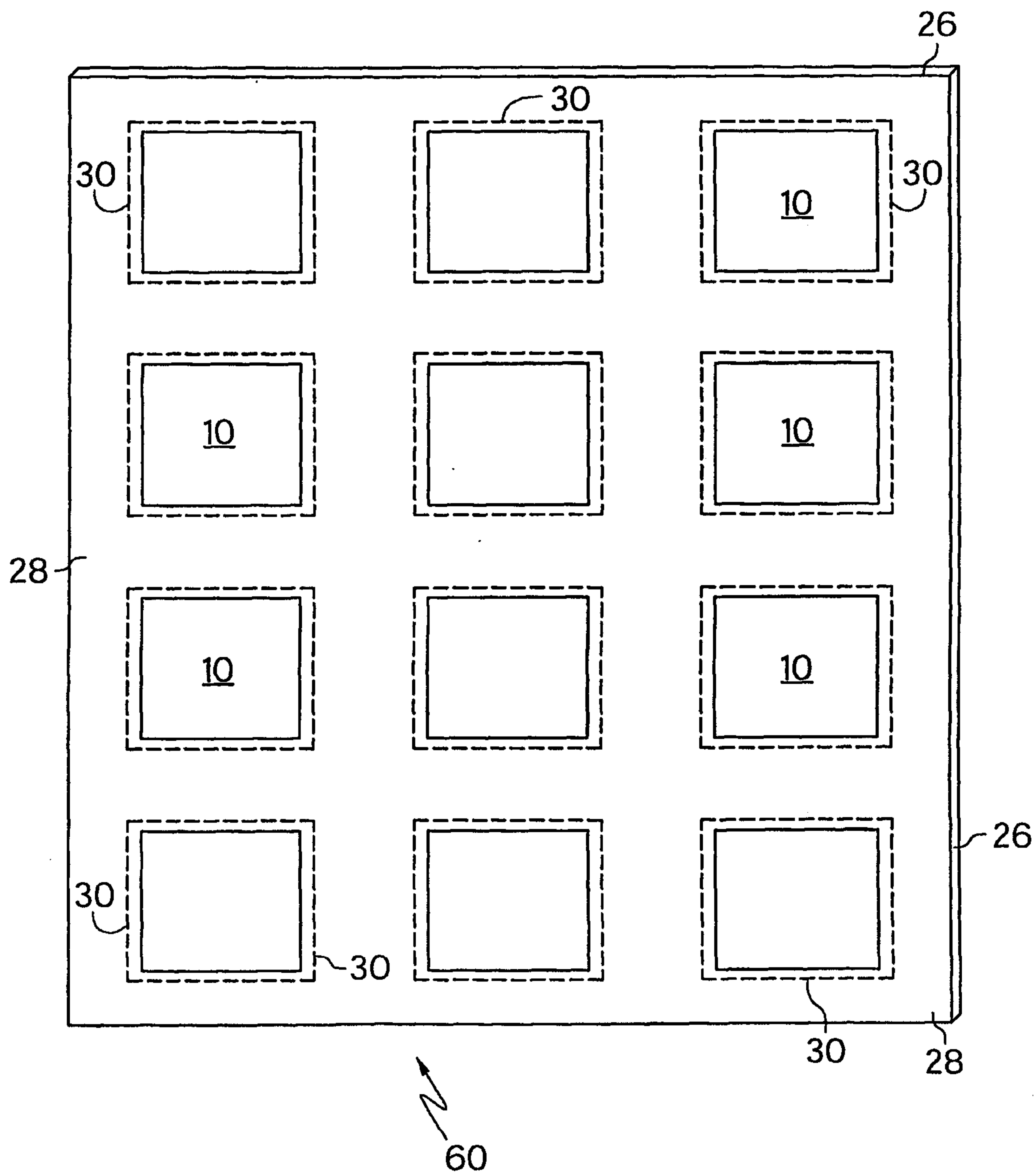

FIG. 13



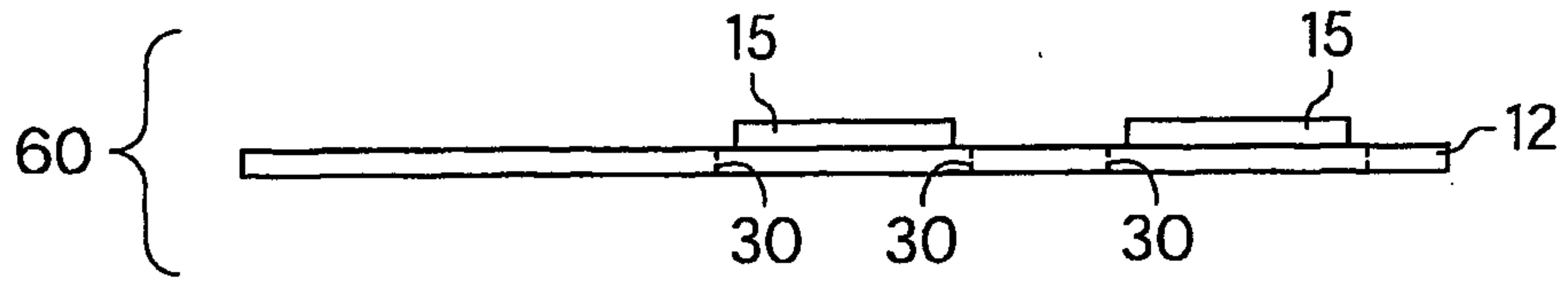

FIG. 14

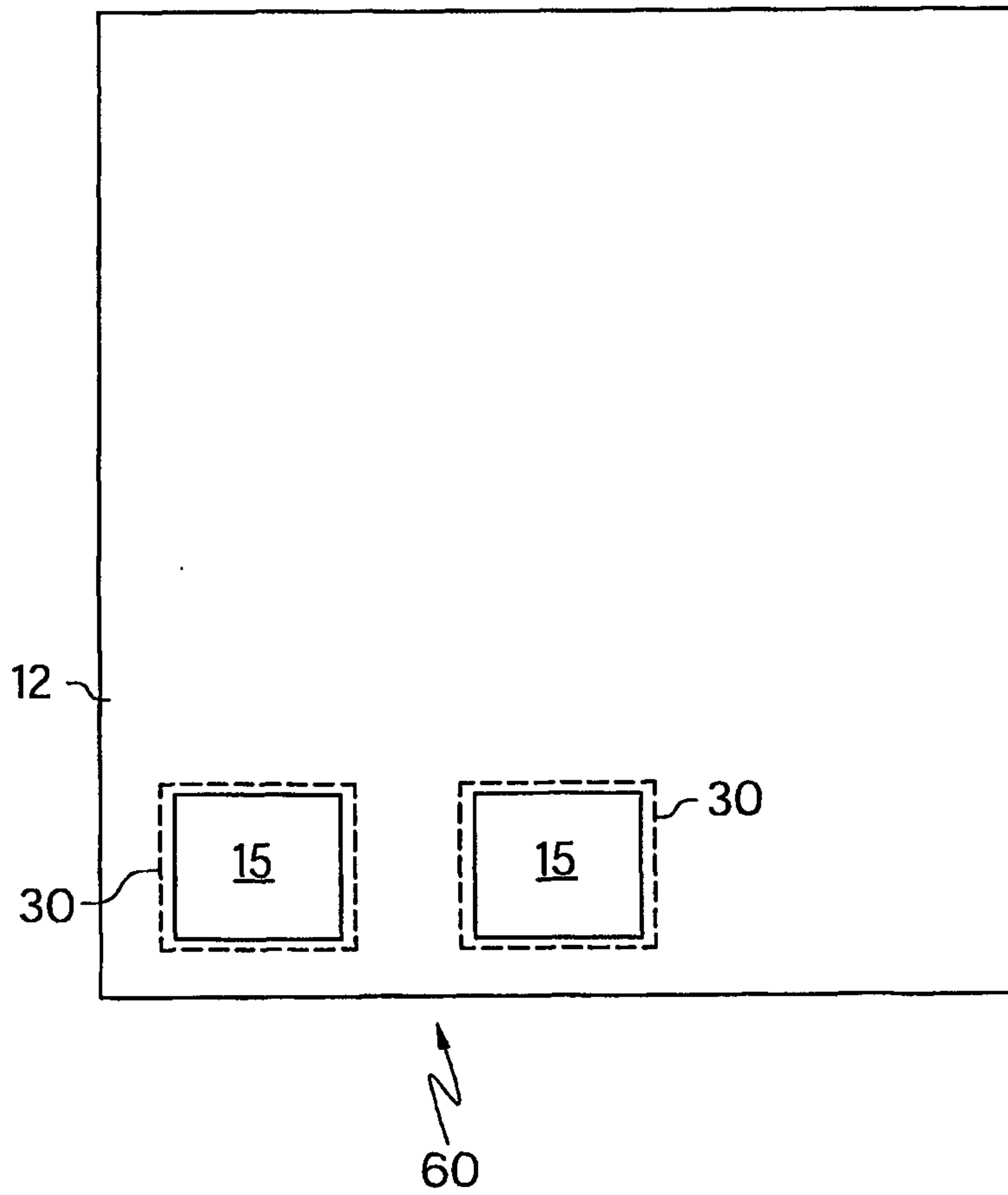

FIG. 15

10



12



14

