

12

, , , , ,

3

(layout)

, ,

(hidden line)

(smooth shadowing),

(texture mapping)

(computer graphics, CG)

가

가 CG

3

() CAD 3
(mirroring), , , ,

가 ,

(shadowing)

(viewpoint)

(polygon)

가 .

(ray tracing)

가

가 ,

가 ,

(blurring)

(blurring)

3
(viewpoint)

가

가

가

가

가

(texture plane)

, 가

(texture mapping)

가

가

가

(blur)

가

(interpolate)

가

, 가

가

,가

가

가

,가

가

가

(a) 3

가

, (b)

가

가

(a)

가

, (b)

(b) (c) 가

,가

(c) 가

(b)

, (c)

가

(b)

가

, (c)

(c)

(c)

(c)

가

,가

(c)

가

(c)

가

가

,가

가

(c)

(a) 3

가

(b)

가

가

가

1

2

(drop shadowing)

3

4

5

(vertax data file)

6

(packet)

7

1

8

1

(rendering list)

9	1			
10		가	(point light source)	
11		가		
12	1			
13	1			
14	1			
15	16		1	
17				
18	19		1	
20	2			가 (umbra)
	(penumbra)			
21	2			(blur) ()
22	2			가
23	3			(trilinear)
24	3			
25	3			
26	3			
27	28		3	
29	3			가
30	4			
				3 CG
		가	1 30	

1 (10) (10) CPU(12),
 (14), CPU(12)
 (, CRT)(16) (18),
 / (20) .

(14), (18), / (20) (22) CPU(12) /
 (20) ((key entry) ,) (10)
 / (24), (- , (texture))
 CD-ROM (26)가 .

(18) (rendering engine)(30), (32), (34),
 가 CRT (36) .

(30) CPU(12) (32) (

34)

1 (38) (32) (30) , 2 (40) (3
 2) (34) . 1 2 (38, 40) (30) (3)
 128 .

(30) 1/60 1/30 10 10 640 x 480 (pixel)
 NTSC PAL 320 x 240 .

(34) (34a) (34b) (3)

(36) (14) (26)
 (32) (34) , (32)
 (14) ,
 (16) .

(10) (" (drop s
 hadowing) ") .

, 2 , 3 (Ob1, Ob2)
 가 (50) , (52) 가 (50) (Ob1)
 (54) (Ob1) (52) (Ob2) (56) .

(14) (26) , (100) (3) (10)
 CD-ROM (download) . (10)
 (10)

(100) 3 9 . 3 , (1
 00) (102), (104), (106), (1
 08) .

(52) (102) , (110) , (Ob1, Ob2, ...), ,
 (Ob1, Ob2, ...) 가 (50) .

4 (110) () ()
 (M), (Gouraud),
 () ,
 가 (/ = 1/0)

(52) (104) 가 (50) (112)
 (packet) (114) (52)
 (114) Z- (Z-sorting) (114) (116)

5 (112)
 $PP_{ij0} = (X_{ij0}, Y_{ij0}, Z_{ij0})$, $PP_{ij1} = (X_{ij1}, Y_{ij1}, Z_{ij1})$, $PP_{ij2} = (X_{ij2}, Y_{ij2}, Z_{ij2})$

6 (114) () (114)
 (116) (pointer) Z- $SP_{ij0} = (X_{sij0}, Y_{sij0}, Z_{sij0})$
 $SP_{ij1} = (X_{sij1}, Y_{sij1}, Z_{sij1})$, $SP_{ij2} = (X_{sij2}, Y_{sij2}, Z_{sij2})$,
 $UP_{ij1} = (X_{uij1}, Y_{uij1}, Z_{uij1})$, $UP_{ij2} = (X_{uij2}, Y_{uij2}, Z_{uij2})$, 가 (50) $UV_{ij0} =$
 (U_{ij0}, V_{ij0}) , $UV_{ij1} = (U_{ij1}, V_{ij1})$, $UV_{ij2} = (U_{ij2}, V_{ij2})$

(106) (116) (114) (114)
 (texture mapping)

(108) (34) (34b)
 (36)

7 (102) / (24)
 (110) (120), (110) /
 (24) (122), (52), 가
 (50) (52), 가 (50)
 (Z1 - Z4) (124), 가 (50)
 가 (50) (25) Z
 (126)

8 (104) (116)
 (130), (110) (132),
 (112) (134), (114)
 (136), (112) , 가 (50)
 (138), (116)
) (140), (114) (Z-
 가 (142),
 (144)

9 (150) , (106) 가 (50) (152) (34) (34a)
 (150, 152)

(106) (30) (154)
 (154) (156) (158)

(106) (178) (Di) (150)
 (152) (150) (152) (16) (110)
 0), (116) (114) (162), 가 (164), (152)
 가 (166), (150) (152)
 (168), (110) (170), (34b)
 () Z- (114)
 가 (172), (116)
 (174)

(100) 1 가
 , (100) 2, 10 12

2 가 (50) 2 , 가 (50)
 (Ob1) 가 (Ob2) . 가 (50)

1 , 가 (50) (Ob1) (52) (viewpoint) 가 (50)
 (150) (Ob2) (150) (152))
 (Ob2)

(52)

11

11 , (52) , (Ob1) 가 (50)
 :

$$Xa = (xa*ScrZ)/za$$

$$Ya = (ya*ScrZ)/za$$

(Ob2)

(Ub,Vb)

:

$$Ub = (xb*ScrZ)/zb$$

$$Vb = (yb*ScrZ)/zb$$

(52) ,

$$(X_a, Y_a) = (x_a, y_a)$$

$$(X_b, Y_b) = (x_b, y_b)$$

12 1 (150) 12
 , (176) (1), 가
 (150) (2). (A) , (52)
 Z- .

1 가 13 .
 (S1) , (102) (110) 가 , (176),
 (52) , (50) ()
).

, (S2) , (104) (112) (52)
) , , 가 (50) ()
 (114) (116) (114) , (52)
 () .

, (S3) , (106) (116) (114) , (114)
 () .

, (S4) , (108) (34) (34b)
 , (36) (16) . 2
 (52) (Ob1) (52) (Ob1)
 (Ob2) .

(S4) , 1 .

(102), (104), (106) 가 14
 19 .

, 14 (102) 가 .
 14 (S101) , (102) (120) / (24)
 (110) .

4 , (110) (Gouraud
), () , 가
 (/ = 1/0).
 (110) , (112) , ,
 가 CAD .

(S102) , (122) / (24)
 (110) .

(S103) , (124) (176) (176)
 , (Z1) .

(S104) , (124) (52) (52)
 , (Z2) . (124) / (24) (52)
 (Z3) .

(S105) , (124) (Z2) (52)
 (110) 가 (50) , 가 (50)
 , (Z4) .

(S106) , (126) (Z4) 가 (50) (52)
 가 (50) , Z (Z5) .

(S105) (102) 가 .
 15 16 (104) 가 .
 15 (S201) , (130) (116) .

(S202) , (104) (i) (i)
 " 0" , (i) .

(S203) , (132) (110) (i)
 (i) .

(S204) , (104) (j) " 0"
 , (j) .

(S205) , (136) (114) , (114) .

(S206) , (136) (i) (i) (114) .

(S207) , (134) (112) (j)
 (j) , j (112)
 (110) i (112)

(S208) , (138) (110) i ,
 (Z1) (176) , j j
 $SP_{ij0} = (X_{sij0}, Y_{sij0}, Z_{sij0})$, $SP_{ij1} = (X_{sij1}, Y_{sij1}, Z_{sij1})$, $SP_{ij2} = (X_{sij2}, Y_{sij2}, Z_{sij2})$,
 (136) (114) .

(S209) , (138) , (Z2) (52)
 , j j $UP_{ij0} = (X_{uij0}, Y_{uij0}, Z_{uij0})$, $UP_{ij1} = (X_{uij1}, Y_{uij1}, Z_{uij1})$, $UP_{ij2} = (X_{uij2}, Y_{uij2}, Z_{uij2})$,
 (136) (114)
 4)

(S210) , (138) , (Z5) 가 (50) Z
 () , j j UV_{ij0} = (U_{ij0} , V_{ij0}) , UV_{ij}
 1 = (U_{ij1} , V_{ij1}) , UV_{ij2} = (U_{ij2} , V_{ij2}) , (136) (114)

(S211) , (140) (S209) UP_{ij0} = (X_{uij0} , Y_{uij0} , Z_u
 ij0) , UP_{ij1} = (X_{uij1} , Y_{uij1} , Z_{uij1}) , UP_{ij2} = (X_{uij2} , Y_{uij2} , Z_{uij2}) Z 가 가 Z ,

16 (S212) , (142) (116) , 17
 , (114) Z (Z-) 가 (114) (

(S213) , (144) (j) " +1" 가 (S214) ,
 (144) (j) (110) i 가 (M)

i 가 , 15 (S205)
 가, (116) , (114) (114)

i 가 (S214) , (S215) ,
 (144) (i) " +1" 가 (S216) , (144)
 (i) (110) (N)

가 , 15 (S203) 가,
 (116) (114) (115) , z- 가

가 (S216) , (104) .
 18 19 (106) 가 .

18 (S301) , (160) (178) (Di)
 , (150) (152)) (152) (Di) (

(S302) , (106) (i) (R) " FF"
 , (114) (k) " 0" , (R) (R)
 (k)

(S303) , (162) (116) (k) ()
 k) (114) . (S304) , (162) (114) (

(S305) , (166) (i) (R)
 , (i)가 .

i (i)가 (S306) (164) (110)

(S307) (168) (152)
 (Di) (150)

(S308) (166) (R) (i)

(S308) 가 (S305) (i)가 19
 (S309) (154) (154) (180)

(S310) (170) (110)
 가

가 (50) $UV_{ij0} = (U_{ij0}, V_{ij0})$
 56) $UV_{ij1} = (U_{ij1}, V_{ij1})$, $UV_{ij2} = (U_{ij2}, V_{ij2})$ (154) (1)
 11) (150) (Di) (S3

(S311) 가 (S310) 가 (152)
 (168) 가 (50) (R,G,B,) = (0,0,0,100%)

(S312)

(S313) (172) Z-
 (34b)

(S314) (106) (k) "+1" 가 (S315) ,
 (174) (114) 가 (114) (114)

가 (S303) (114)

(S315) (116) (114) 가 (106)

(S303 - S313) : (52) 가 (Ob
 1) (Di) (150) (Di)가 ,
 (Ob1)

(52) 2 (Ob2) 1 (Ob1)
 가 , (Ob1)

2 (Ob2) 가 , 1 (Ob1) 2 (Ob2)

(52) 3 (Ob3) 1 (Ob1) 2
 (Ob2)

(152) . 22 , (152)
(P1, P2, P3)
2 (52) (152)
, (52)
23 29 3 가 .
3 (152)
(150) , (,) ,
23 , 2 , (150) (192)
(150) Z (192) (150, 192) (interpolation)
(trilinear) , (52)
3
3 (102) (106)
1
, 24 , (102) (120), (122),
(124), (126)
(126) 가 (50) 가 (50) , Z
가 (Z5) 1 n 가 Z
(Z11 - Z1n)
25 , (106) (150) (152) 가 , 1
n 가 (34) (34a)
(192)
(106) (160), (162), (164),
(166), (168), (170), (168),
(172), (174) (160), (168),
(190)
(160) (Fi) (150) (152)
(192) , (150, 152, 192)

(168) (52) 가 (50) (가 (50) Z) (52)
 가 (1 n 가 Z) , 가 (50)
 ((150))가 가 (192)
 1 n 가 (190) (152) , (192)
 26 28 3 .
 26 (S401 - S404) 1 (102)
 (S101 - S104) , (102) (110) (176) (110) ,
 (52) (52) .
 (S405) , (124) (110)
 (Z2) (52) 가 (50) 1 n 가 ,
 가 (50) 1 n 가 (Z4, Z11 - Z1n) .
 (S406) , (126) (Z2, Z4) (52) 가 (50)
 가 (50) 1 n 가 (Z5, Z21 - Z2n) .
 (104) 1
 (104) 가 .
 78) , 27 (S501) , (106) (160) (1
 (Di) , ((150), (152),
 (192)) (Di) , (150, 152, 192) .
 (S502) , (106) (i) (R) " FF"
 , (114) (n) " 0" (k) " 0" , 가 (k, n)
 (R) .
 (S503) , (162) (116) (k) (k
) (114) . (S504) , (162) (114) ()
 i) .
 (S505) , (116) (i) (R)
 (i)가 .
 (i)가 (164) (110)
 i (S506) .
 (S507) , (168) (152)
 (150) .
 (S508) , (190) (152)

(S509) , (166) (R) (i) , (106)
 (n) " +1" 가 .

(S510) 가 , (S505) (i)가 ,
 28 (S511) , (154) (180)
 , (154)

(S512) , (170) (110)
 가

가 , (S513) , (170)
 (i)가 " 0" 가 .

가 , Z (S514) , (168) 가 (50) Z n
)가 , 가 (50) n 가 (150)
 (192)

(S515) , (190) (192)
 , (52)

(S516) , (154) (156) (150)
 , (192)

29 , (200)
 (150) , (204) n (202n)
 06) , (200) n 가 (200) (202n) (2
 (204) n (202n) (150)
 (206)

(S513) , (S517) , (156) 가 (50)
 , (150)

(S516) , 가 , (S518) ,
 (168) 가 (50) (152) , (R,G,B,) = (0,0,0,10
 0%)

(S519) , (172) Z -
 (34b)

(S520) , (106) (k) " +1" 가 , (S521) ,
 (174) (114) 가 . (114) 가
 , (114)
 , (S503)

(S521) (116) (114) 가 , (106)

(S503 - S519) : (52) 가 (O
b1) , (Di) (150) (Di)가
, (Ob1)

(52) 2 (Ob2) 1 (Ob1)
가 , (Ob1)
2 (Ob2) 가 , 1 (Ob1) 2 (Ob2)
, (Ob2) (S516) (
(Ob2)

, (52) 3 (Ob3) 1 (Ob1) 2
(Ob2) (Ob3)

3 , (152) 가
가 ,

30 4 가
4 30 (210)
(Ob1, Ob2, Ob3) (210) 가 (50)

, (210) (212) 9 1 2 (106) 2
5 3 (106) (Di)

3 (106) (160) 2
7 (Di) (S501) (150), (152), (192)
, (S503 - S519) (210)
(210) (S515) (210)

(P0) (210) (212) (152) (P
1) (Ob1) 가 , (210) (212a)
(Ob1) (214) (152) (P2) (Ob2) 가
, (210) (212b),
(Ob1) (214a), (Ob2) (216) (152)

(210)
(150)

4
 52, 192) (210) (Di) (210) , (210) (210) (212) (150, 1
 (210) 가 가 ,
 Z- Z- . ,
 Z- .

- (1) 가 .
 - (2) .
 - (3) (blurring) 가 .
 - (4) , .
 - (5) 가 .
- 가 , .

(57)
 1.
 :

3 (Ob1, Ob2) 가 (50)
 ;
 (viewpoint) (52) 가 (50) (Ob1) (56)
 (Ob1) (52) (Ob2) ,

- 2.
 1 ,
 (Ob1, Ob2) (56)가 (Ob1, Ob2)
 ;
 (Ob2) (56) ,

3.
 1 2 ,

가 (50) (texture plane) (150) ;

가 (50) (Ob1) (56) (150)
;

(Ob2) (150) (56) (texture mapping)

4.

3 ,

(56) (Ob2) 가 (50)
(Ob2) (Ob2)

(56) , .

5.

3 4 ,

(56) (Ob2) (Ob2)
(Ob2) (56) ,

6.

3 5 ,

(52) (viewpoint) (Ob1, Ob2) ;

(52) 가 (50) (Ob1, Ob2)

;

(Ob1, Ob2)
(Ob1) (56) (150) ,

7.

6 ,

(Ob1, Ob2) (Ob1, Ob2) (Ob1, Ob2) 가 (50)
(Ob1, Ob2) ;

(52) (116) ;

(150) (56) (116)

,

8.

6 7 ,
 (52) (150) (56) (56) (blur)

9.

8 ,
 (interpolate) (Ob2) (56) (blur) (150) (56)

10.

6 9 ,
 (150) (152) ;
 (56) (150) (switch) (152)
 , 가 (150) (56)가 (54) (56) (152)
 152) , (50) , .

11.

10 ,
 (152) (56)가 (150)
 (152) (56) , .

12.

11 ,
 가 (150) (152) 가 , (52)
 ; 가 (192)
 가 (50) (204) 가
 (192) ;
 (150) (204), (192) (20
 6), , .

13.

3 12 ,
(150) (210) ;
(210) , .

14.

3 (Ob1, Ob2) 가 (50)
1 (102);
(52) 가 (50) (Ob1) (56) (Ob1)
(52) (Ob2) 2 (104) , .

15.

14 ,
1 (102) (Ob1, Ob2) (56)가 (Ob1, O
b2) (Ob2) (56) , 2 (104) , .

16.

14 15 ,
2 (104) 가 (50) (150) ,
가 (50) (Ob1) (56) (150)
, (150) (56) (Ob2)
(106) , .

17.

16 ,
(106) 가 (50) (Ob2)
(Ob2) (56) , .

18.

16 17 ,
(106) (Ob2) (Ob
2) (56) , .

19.

16 18 ,
 52) 2 (104) (52) (Ob1, Ob2) , ((가 (50) (Ob1, Ob2) (138) , (106) (Ob1, Ob2) (Ob1) (56) (150) , .

20.

19 ,
 가 2 (104) (Ob1, Ob2) (Ob1, Ob2) (50) (Ob1, Ob2) (52) (116) (142) , (106) (150) (56) (116) , .

21.

19 20 ,
 (56) (106) (52) (150) (56) (56) , .

22.

21 ,
 (106) , (Ob2) , (1 (50) (56) , , , .

23.

19 22 ,
 (106) (150) (152) , (56) (150) (56)가 (56) (152) , 가 (50) (54) (56) (152) , .

24.

23

(106) (152) (56)가 (150)
(152) (56)

25.

24

가 (106) (150) (152)
(52) 가 가
(192) (50) (204) 가
(192) (192) (206), (150) (204),

26.

16

25

(106) (150) (210)

(210)

27.

:

(a) 3 (Ob1, Ob2) 가 (50)

(b) (52) 가 (50) (Ob1) (56)
(Ob1) (52) (Ob2)

28.

27

(a) (Ob1, Ob2) (56)가 (Ob1, Ob2)
(Ob2) (56) (b)

29.

27 28 ,

(b)

(c) 가 (50) (Ob1) (56) (150) , 가 (50)
 (150) (56) (150) ,
 (Ob2)

30.

29 ,

(c) 가 (50) (Ob2)
 (Ob2) (56) , .

31.

29 30 ,

(c) (Ob2) (Ob2)
 (56) , .

32.

29 31 ,

(b) (52) (Ob1, Ob2) , (52)
 , 가 (50) (Ob1, Ob2)
 (c) (Ob1, Ob2) (Ob1, Ob2)
 (Ob1) (56) (150)

33.

32 ,

(b) (Ob1, Ob2) (Ob1, Ob2) 가 (5)
 0) (Ob1, Ob2) , (52)
 (116) , (c) (15)
 0) (56) (116)

34.

32 33 ,

(c) (52) (150) (56)
, (52) (56)
, .

35.

34

(c) , (Ob2) , (150)
(56) , (56) , .

36.

29 35

(c) (150) (152) ,
(150) , 가 (50) (150) 가 (56)
(152) , 가 (54) (56)

37.

36

(c) (152) (56)가 (150)
, (152) (56) ,

38.

37

(c) (150) (152) 가 , (52)
, 가 (50) 가 (192)
(192) (192) (204) 가 (150) (204),
(206), , .

39.

29 38

(c) (150) (210) , (210)
, .

40.

- (a) 3 ; (Ob1, Ob2) 가 (50)
- (b) (52) 가 (50) (Ob1) (56) (Ob1)

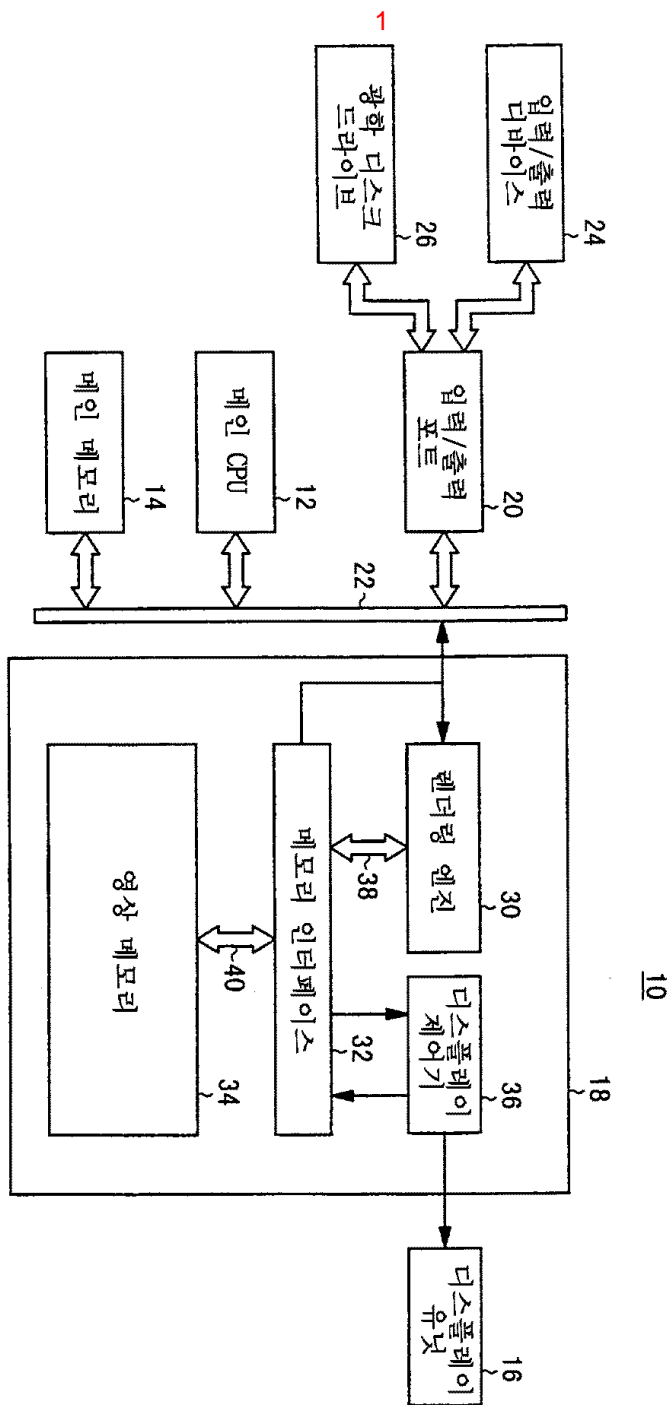

2

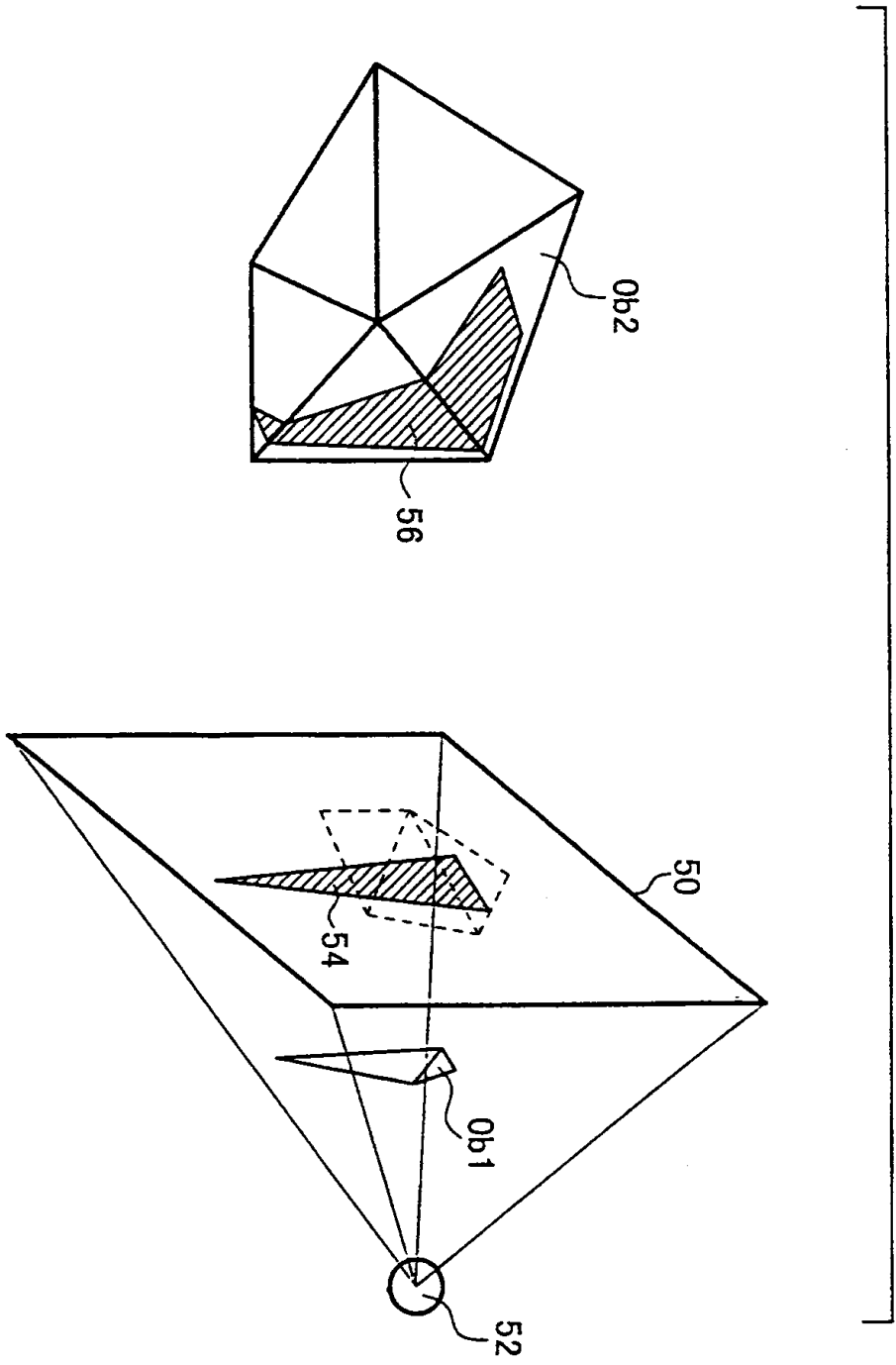

3

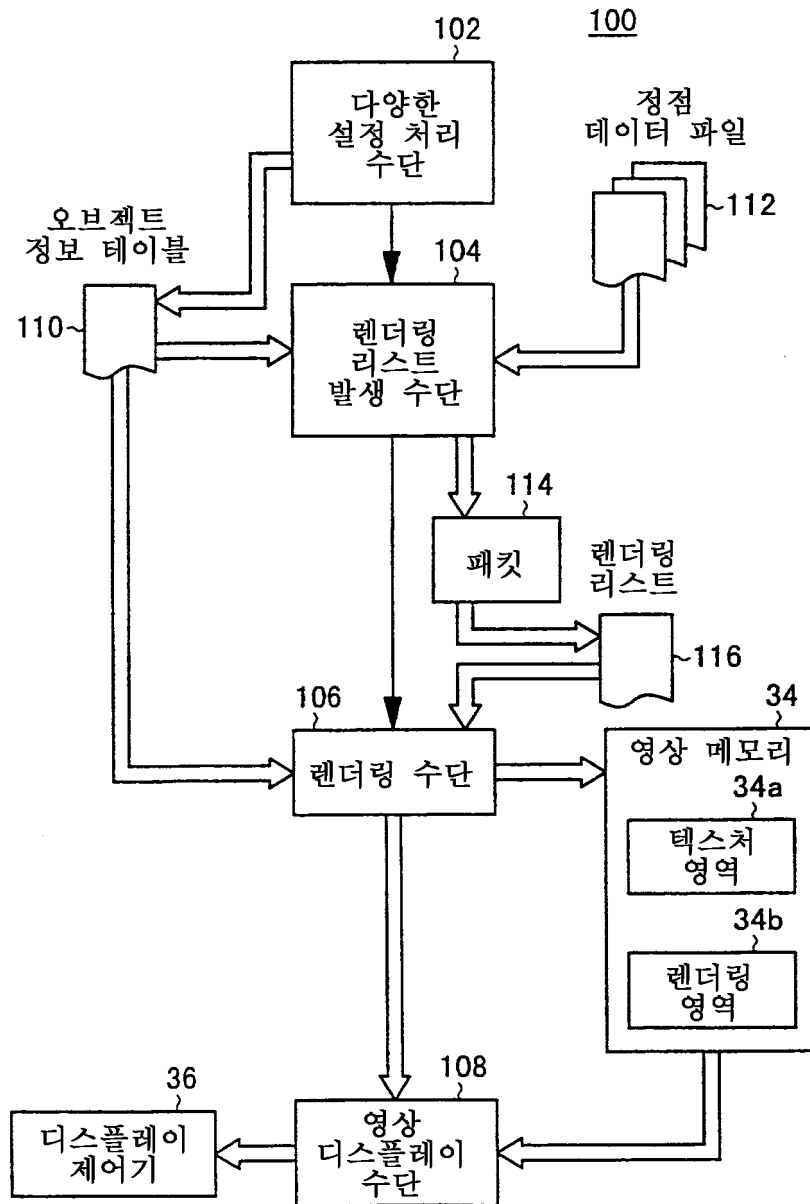

—————▶ 제어 흐름
 ==>▶ 데이터 흐름

기록 0

- 정점 데이터 수 M 파일의 초기 어드레스
- 텍스처 데이터 수 M 파일의 초기 어드레스
- 셰이딩 정보 : GOURAUD 셰이딩 등
- 기하형 처리 정보 : 망사형 등
- 광원 처리 정보 : 디스플레이될 폴리곤 그림자 (디스플레이되지 않음 = 1/0)
- 오브젝트 배치 정보

기록 1

- 정점 데이터 수 M 파일의 초기 어드레스
- 텍스처 데이터 수 M 파일의 초기 어드레스
- 셰이딩 정보 : GOURAUD 셰이딩 등
- 기하형 처리 정보 : 망사형 등
- 광원 처리 정보 : 디스플레이될 폴리곤 그림자 (디스플레이되지 않음 = 1/0)
- 오브젝트 배치 정보

기록 2

- 정점 데이터 수 M 파일의 초기 어드레스
- 텍스처 데이터 수 M 파일의 초기 어드레스
- 셰이딩 정보 : GOURAUD 셰이딩 등
- 기하형 처리 정보 : 망사형 등
- 광원 처리 정보 : 디스플레이될 폴리곤 그림자 (디스플레이되지 않음 = 1/0)
- 오브젝트 배치 정보

.....

.....

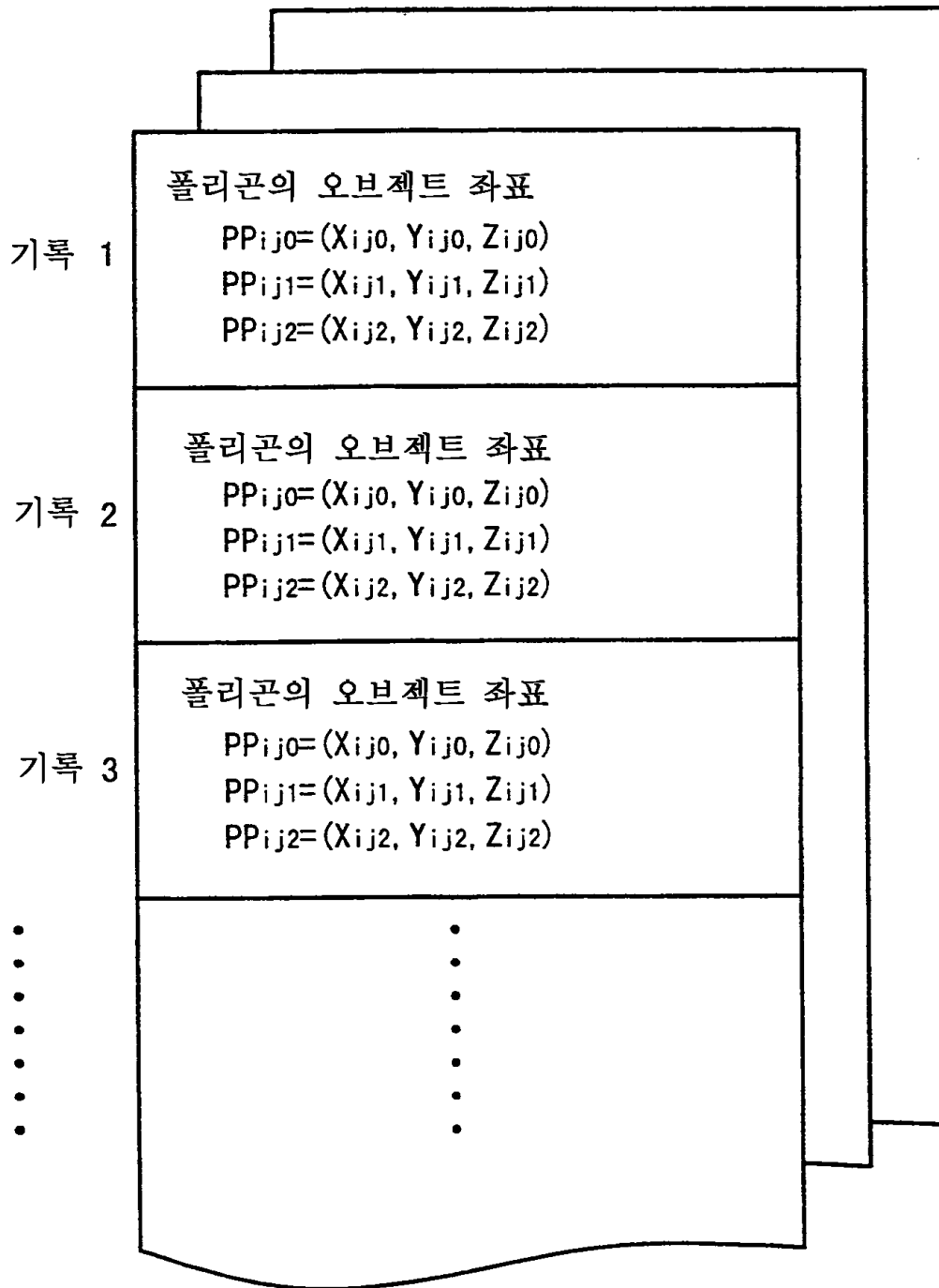

오브젝트 NO.	Z-분류 포인터
<p>폴리곤의 화면 좌표</p> $SP_{ij0} = (X_{sij0}, Y_{sij0}, Z_{sij0})$ $SP_{ij1} = (X_{sij1}, Y_{sij1}, Z_{sij1})$ $SP_{ij2} = (X_{sij2}, Y_{sij2}, Z_{sij2})$	
<p>폴리곤의 광원 좌표</p> $UP_{ij0} = (X_{uij0}, Y_{uij0}, Z_{uij0})$ $UP_{ij1} = (X_{uij1}, Y_{uij1}, Z_{uij1})$ $UP_{ij2} = (X_{uij2}, Y_{uij2}, Z_{uij2})$	
<p>가상 평면에 투사된 폴리곤의 좌표</p> $UV_{ij0} = (U_{ij0}, V_{ij0})$ $UV_{ij1} = (U_{ij1}, V_{ij1})$ $UV_{ij2} = (U_{ij2}, V_{ij2})$	

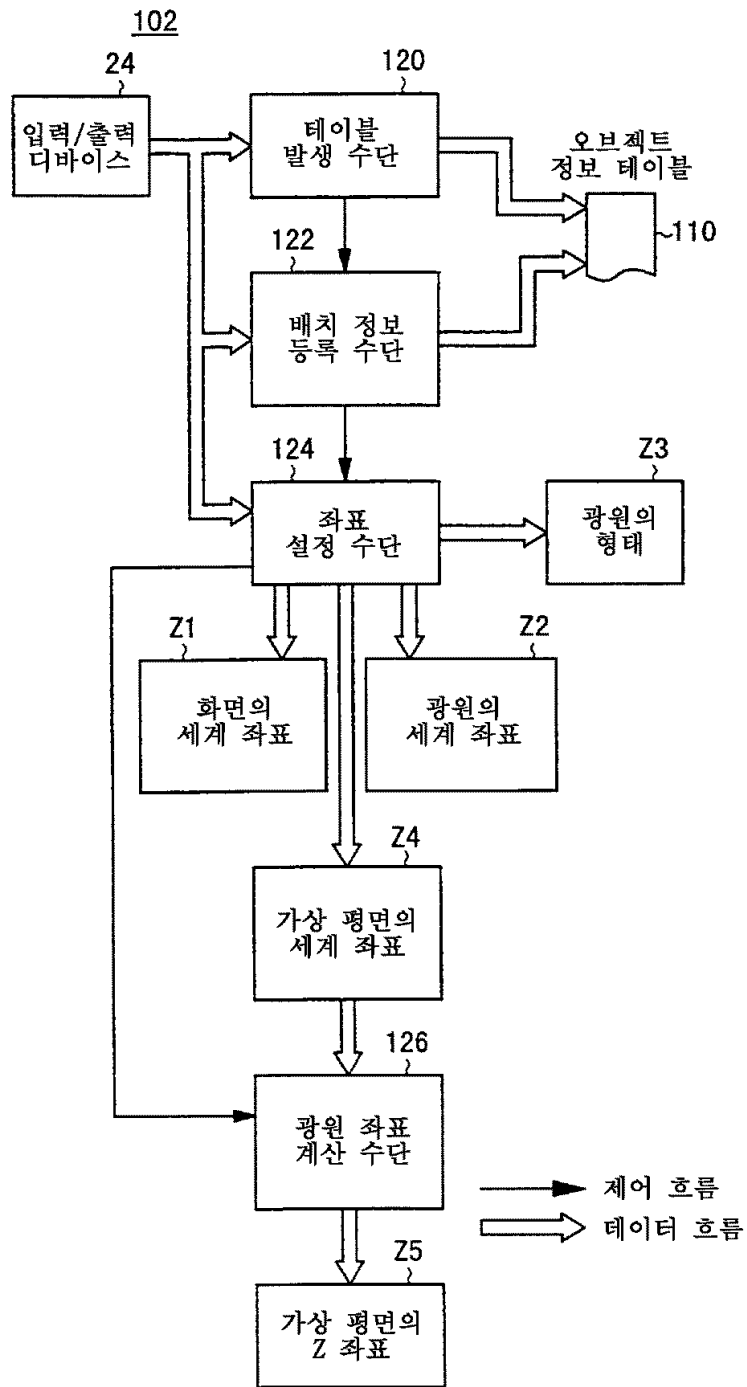

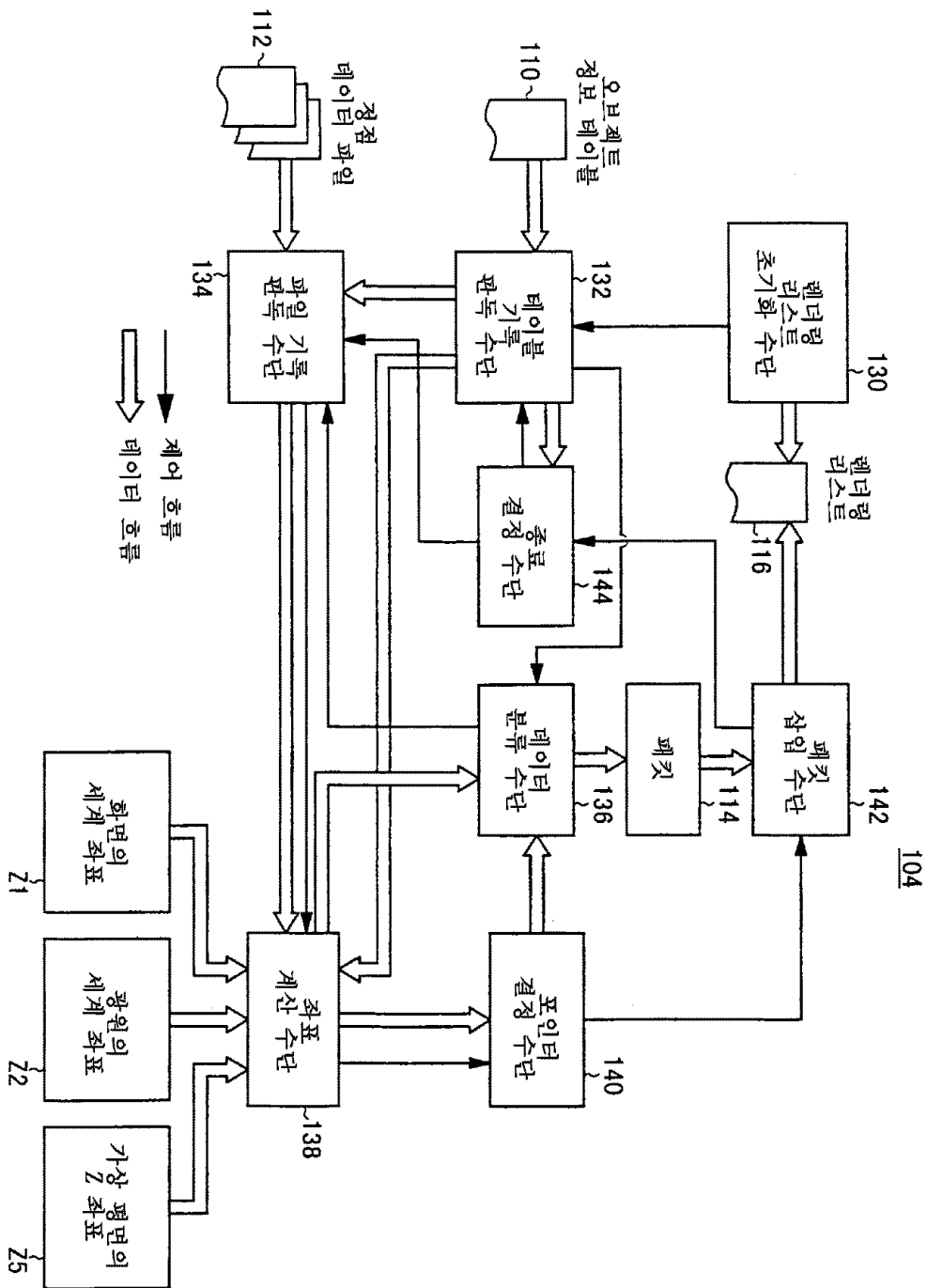

9

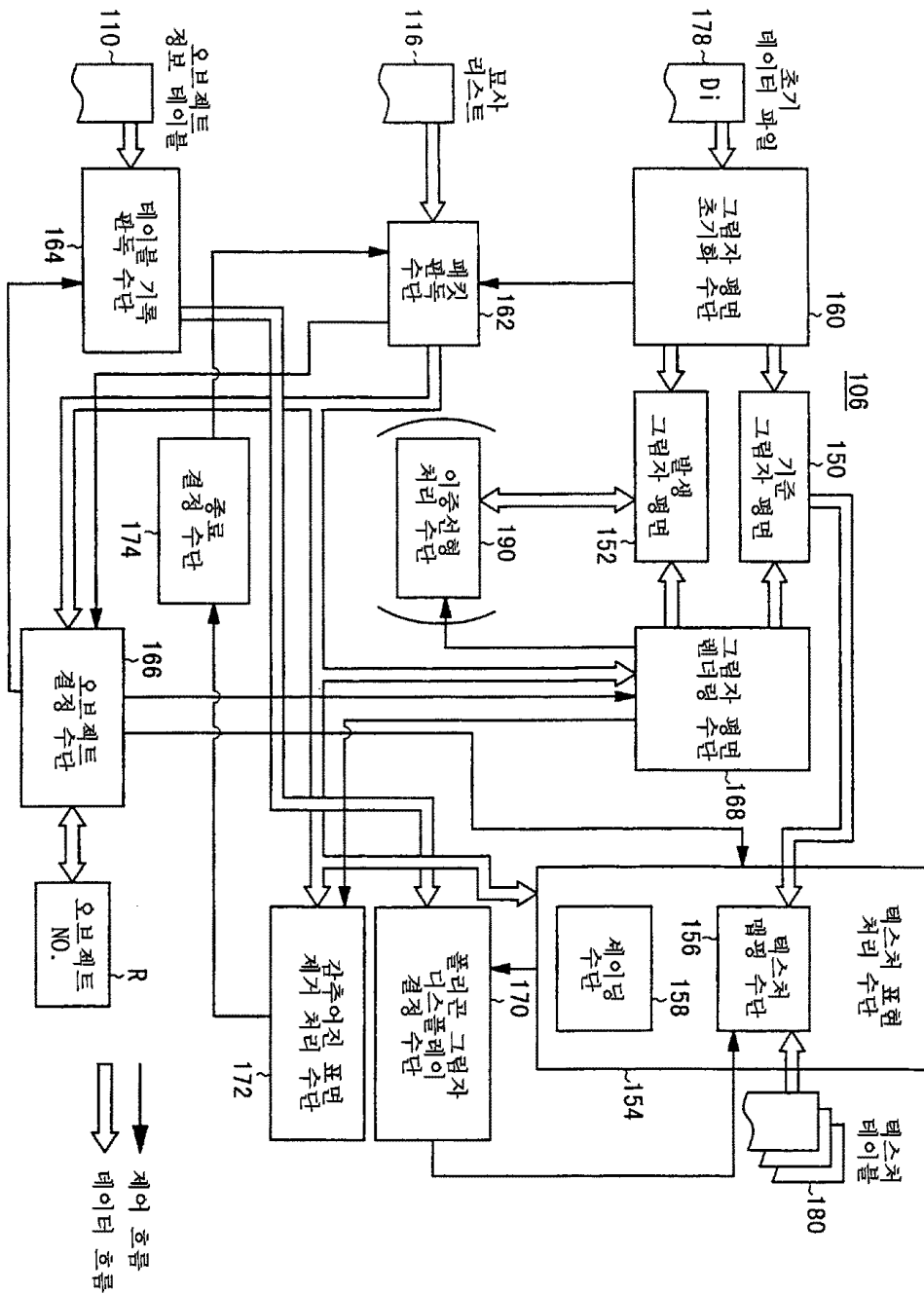

10

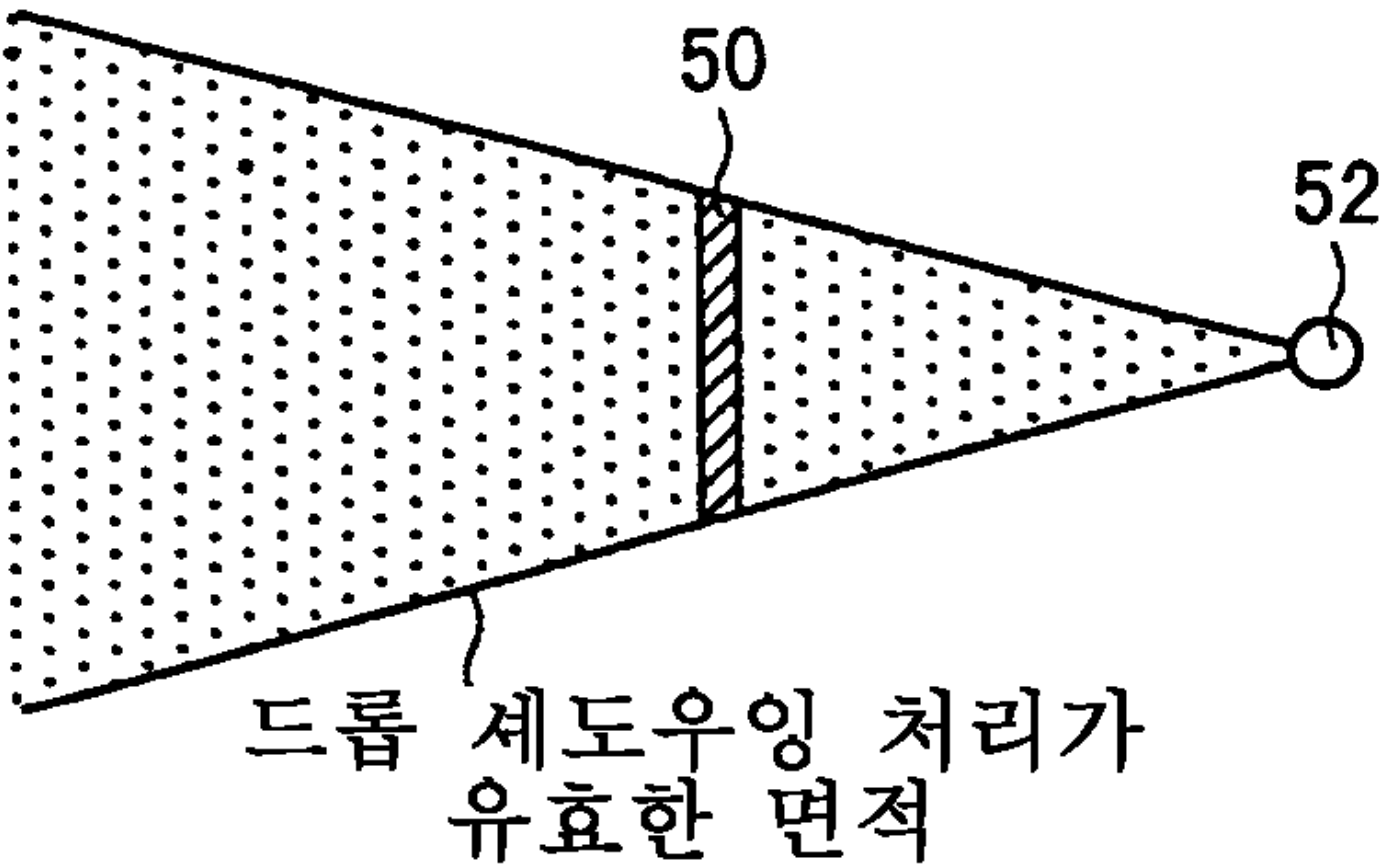

11

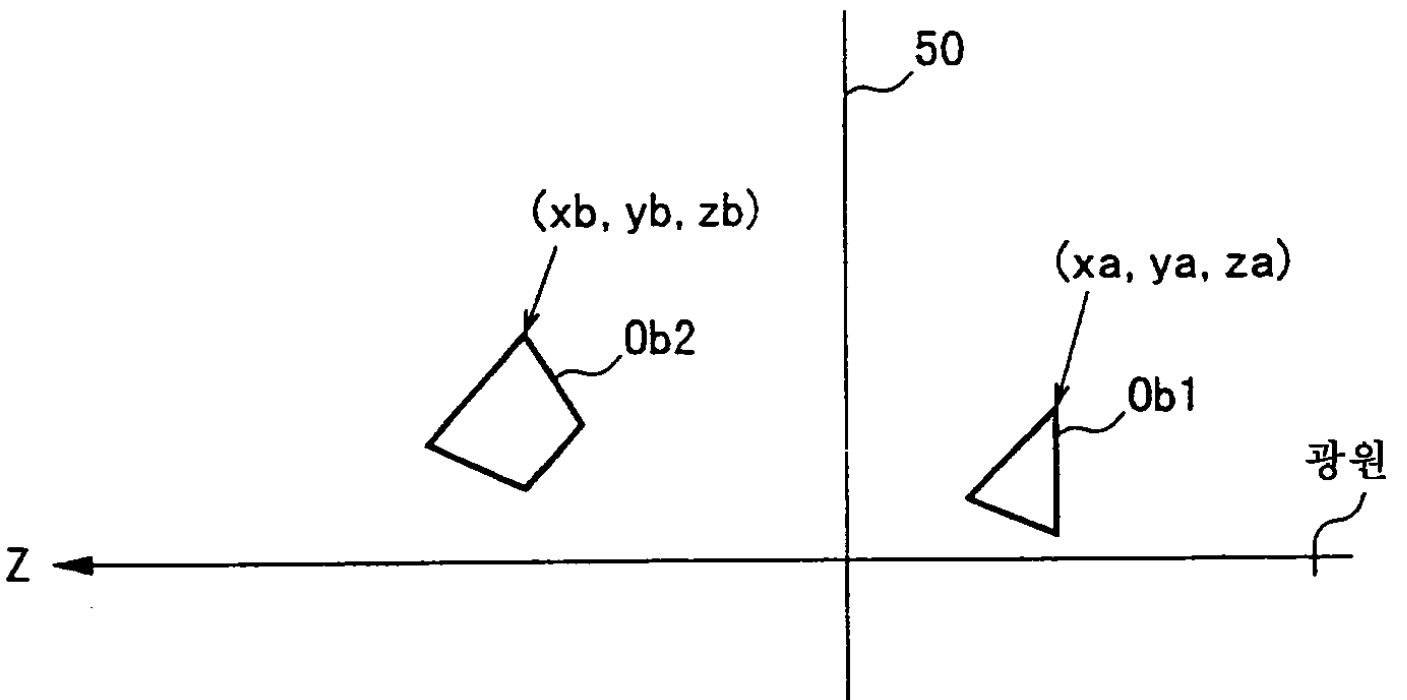

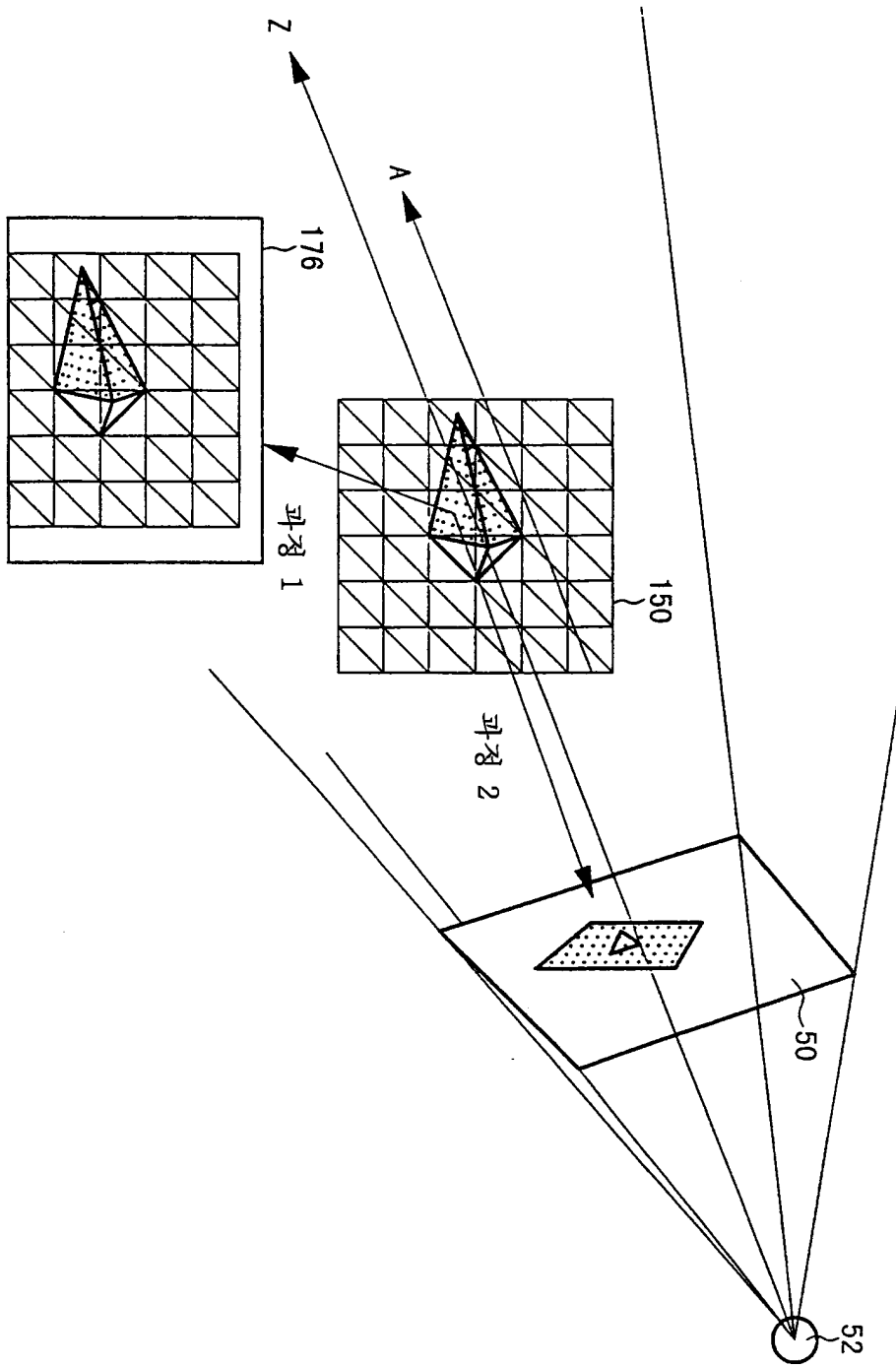

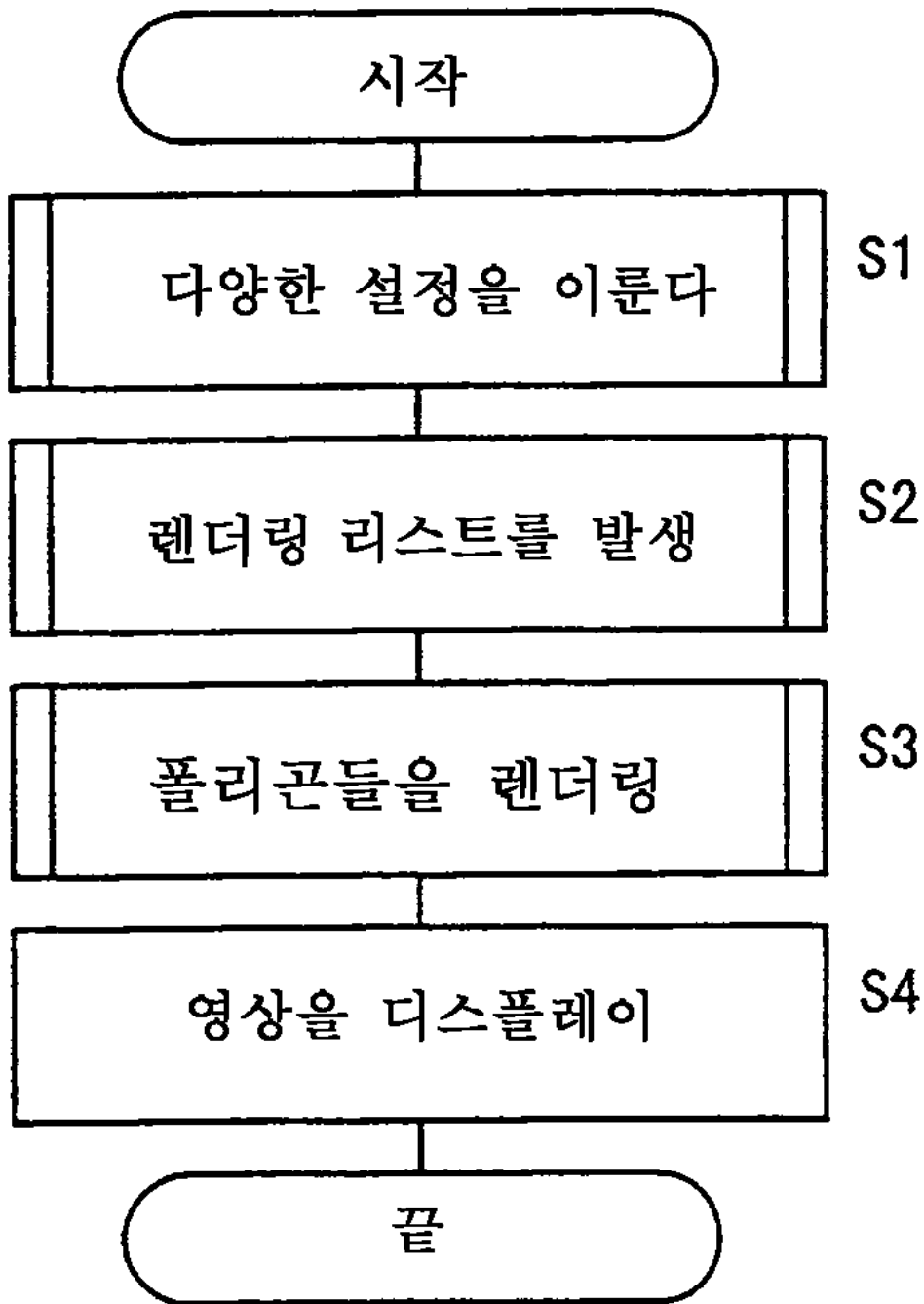

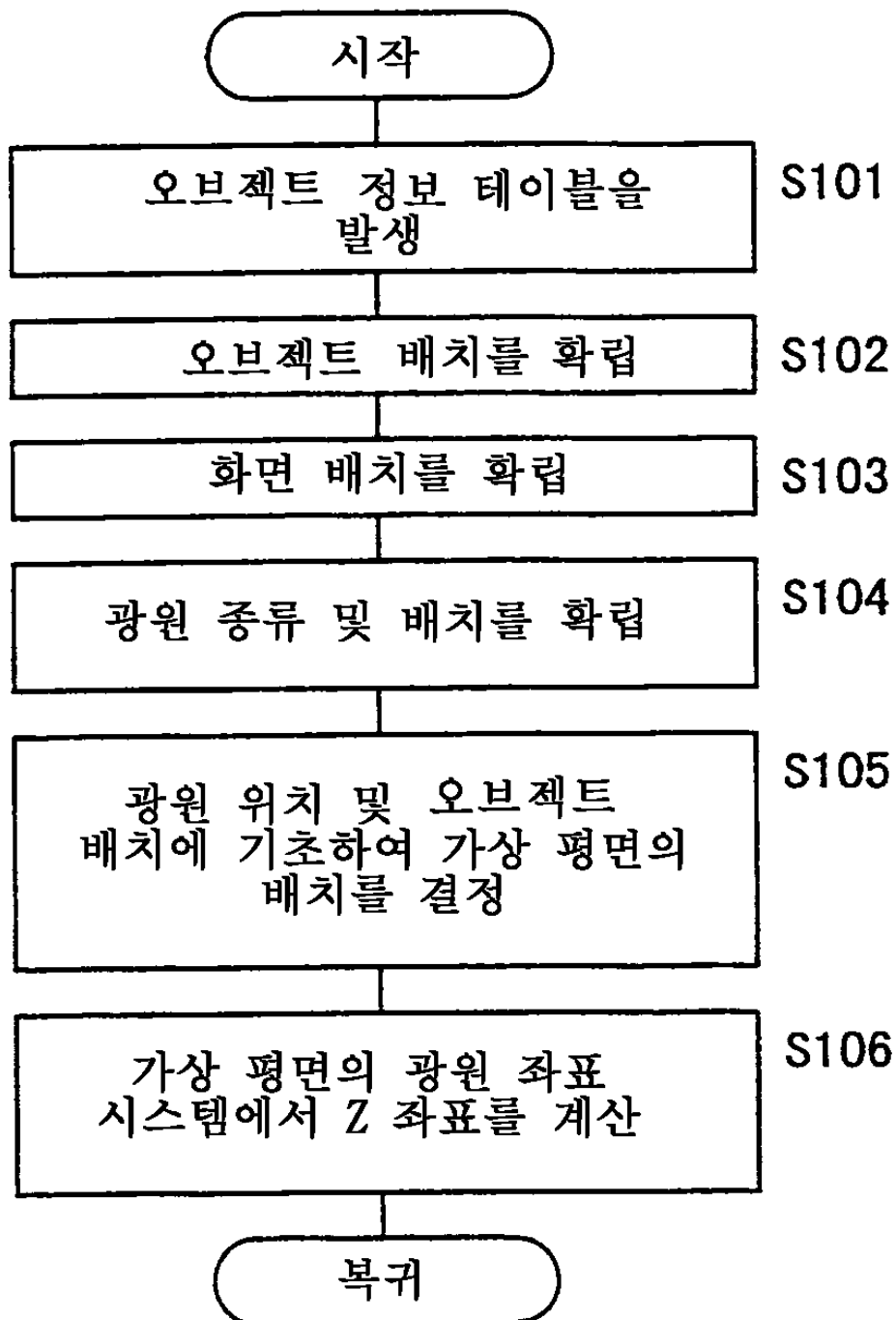

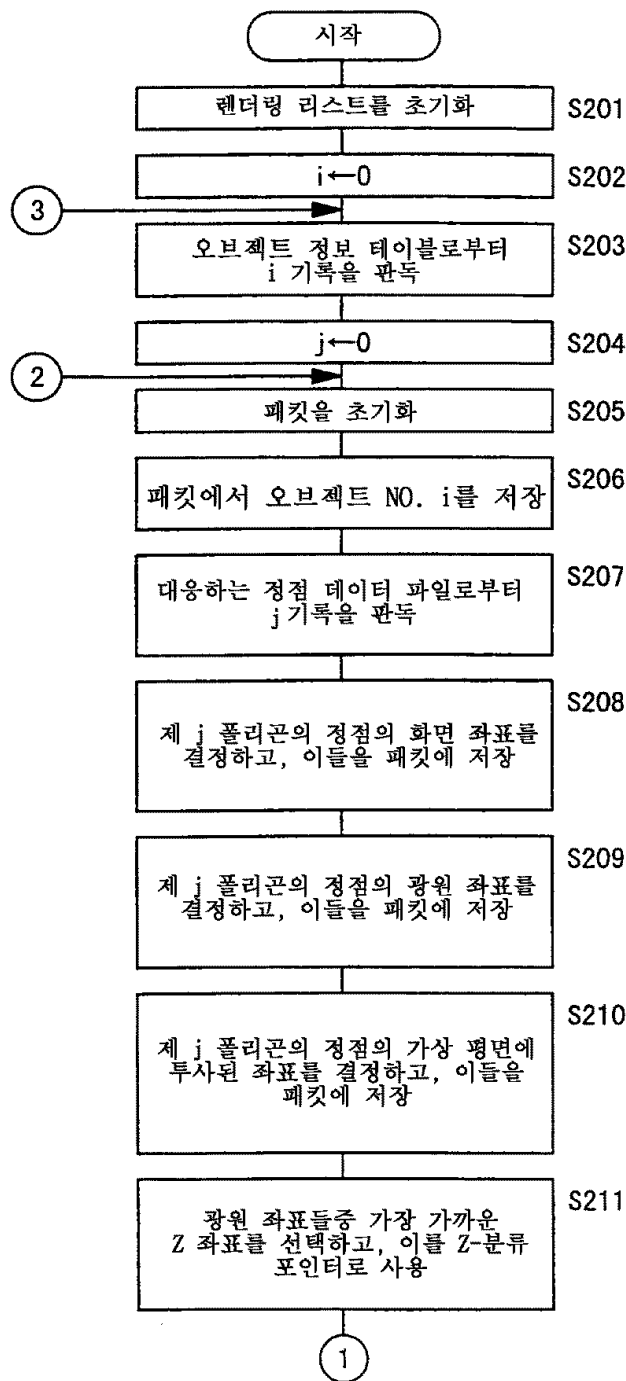

16

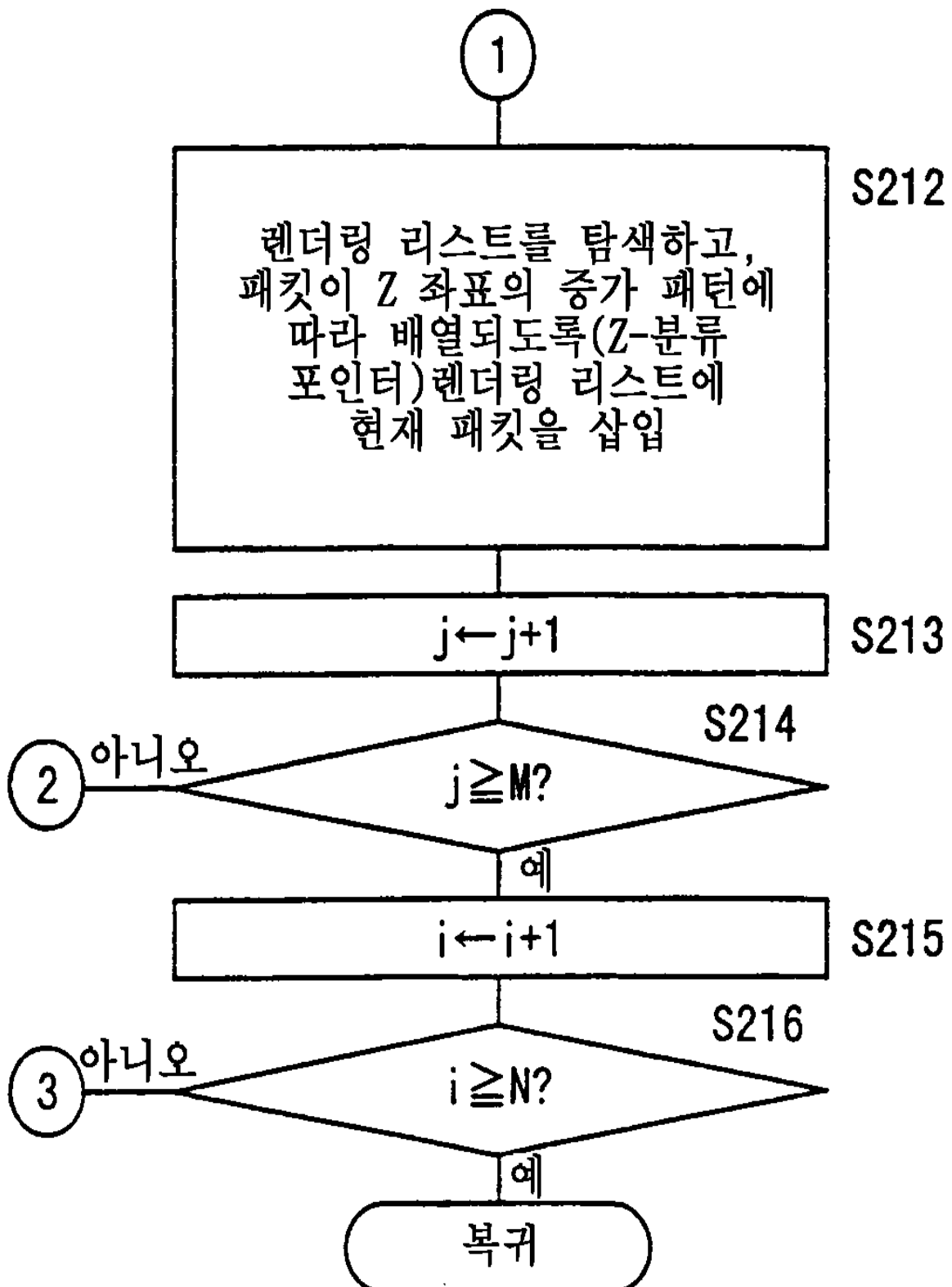

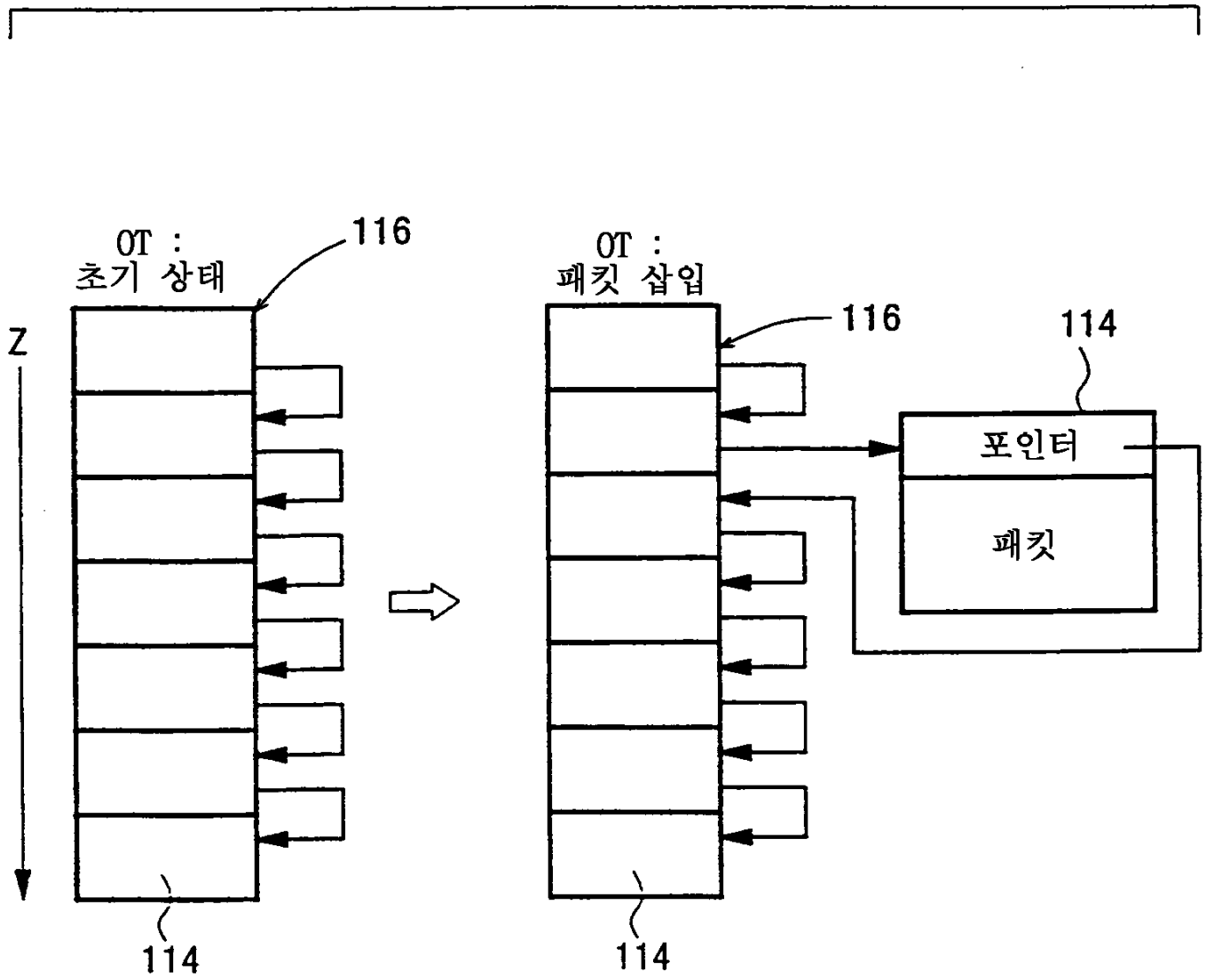

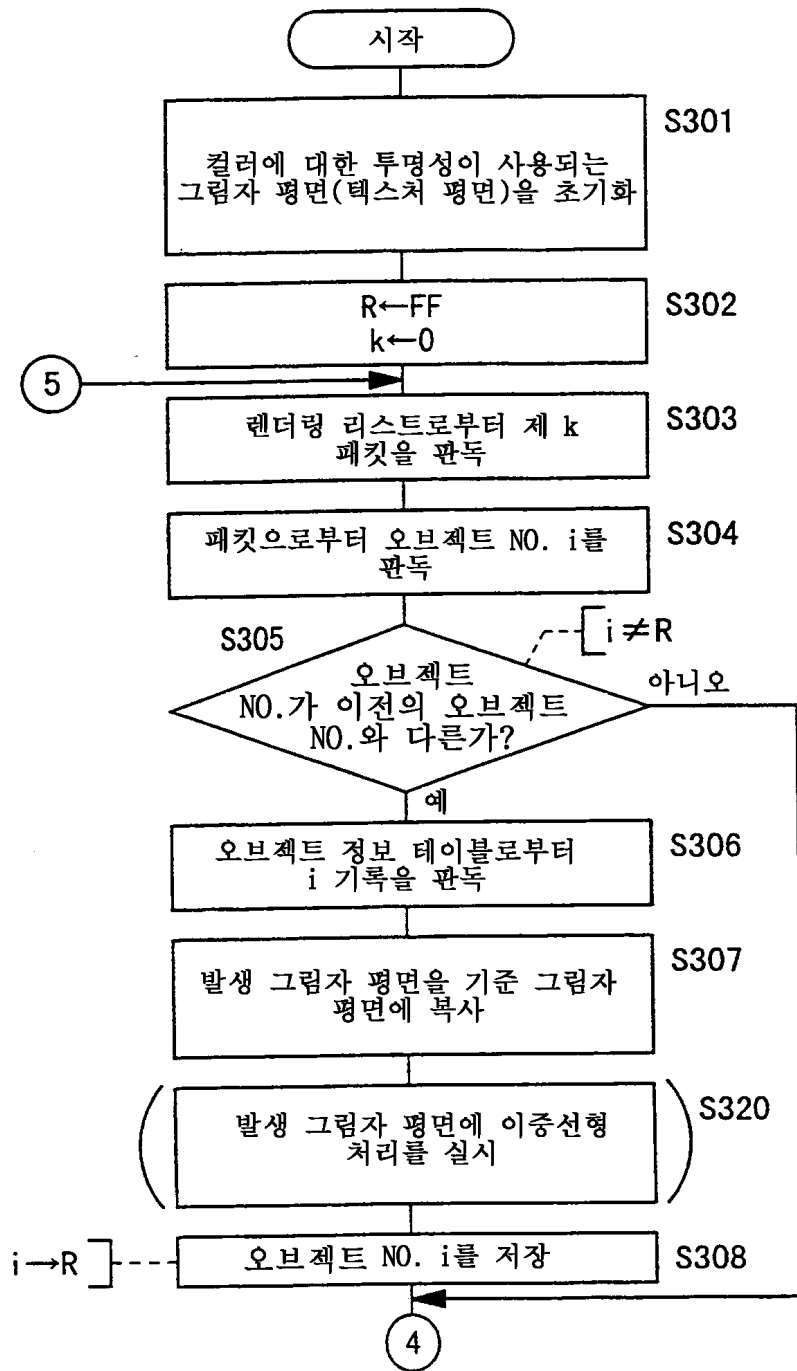

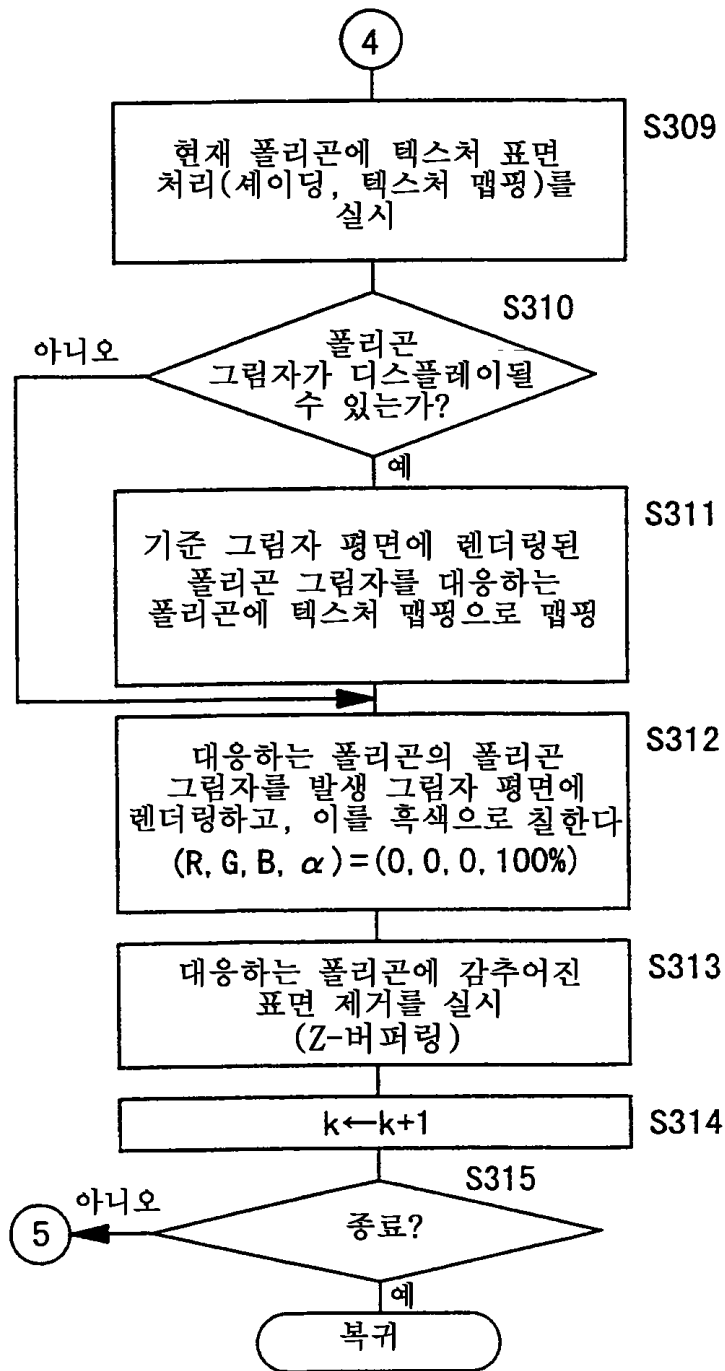

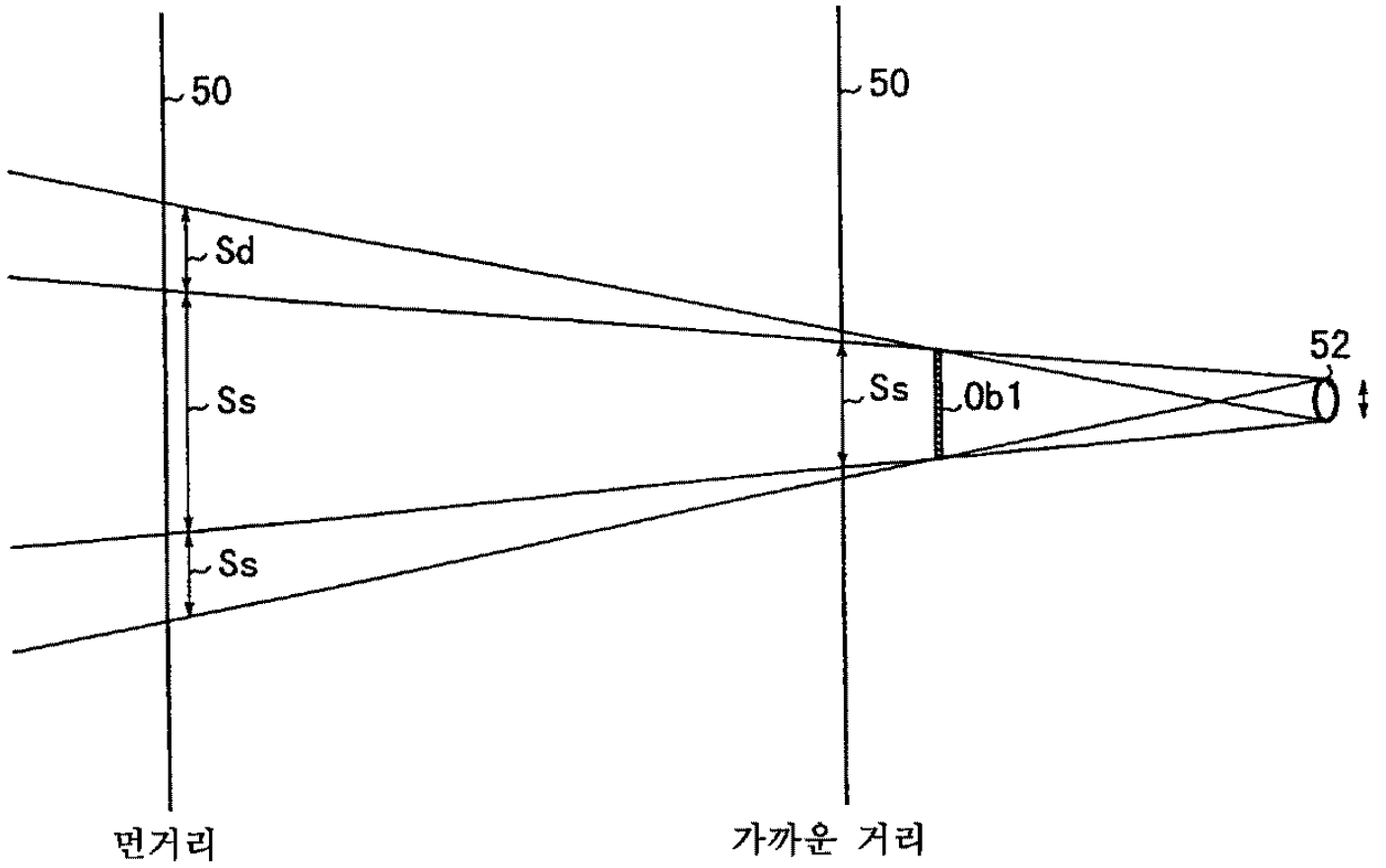

21

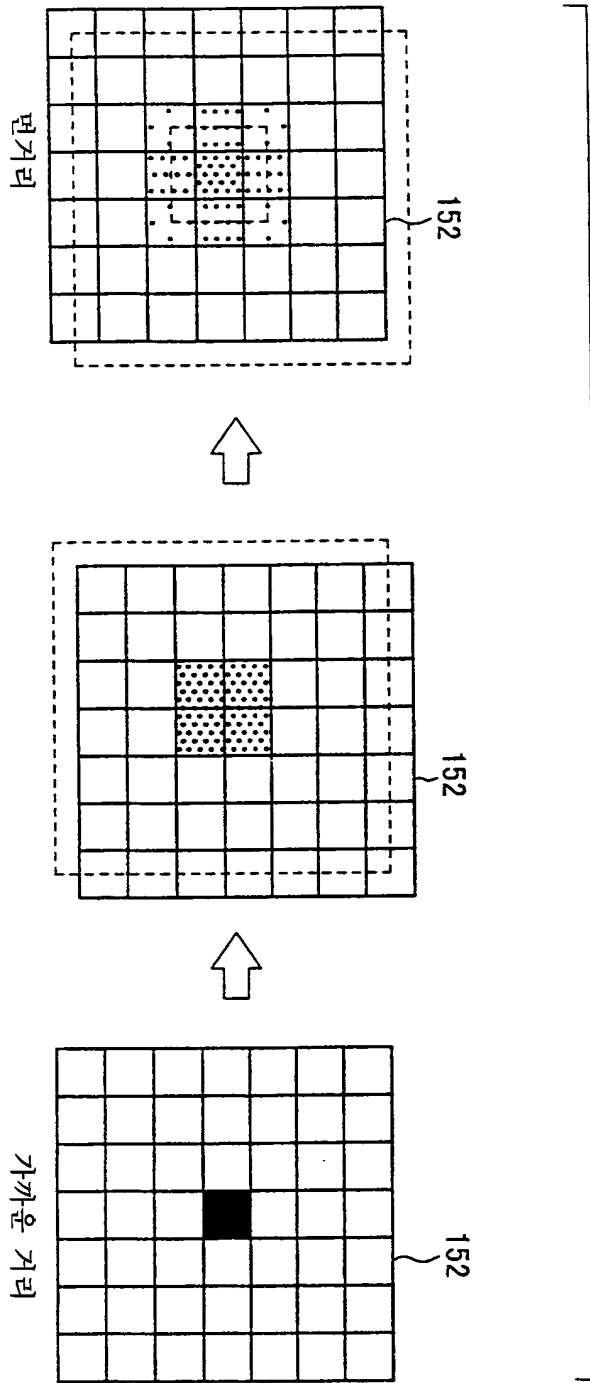

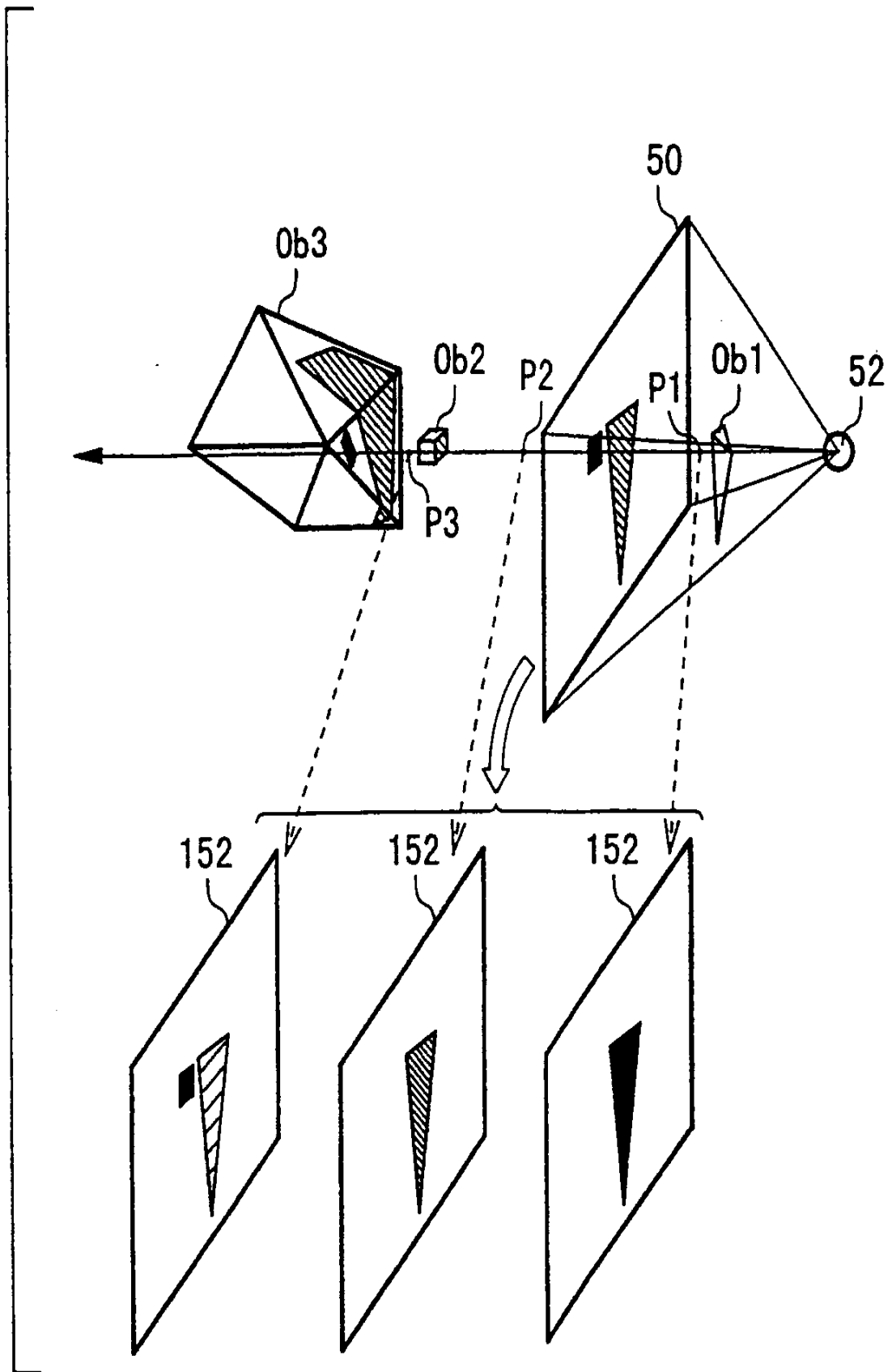

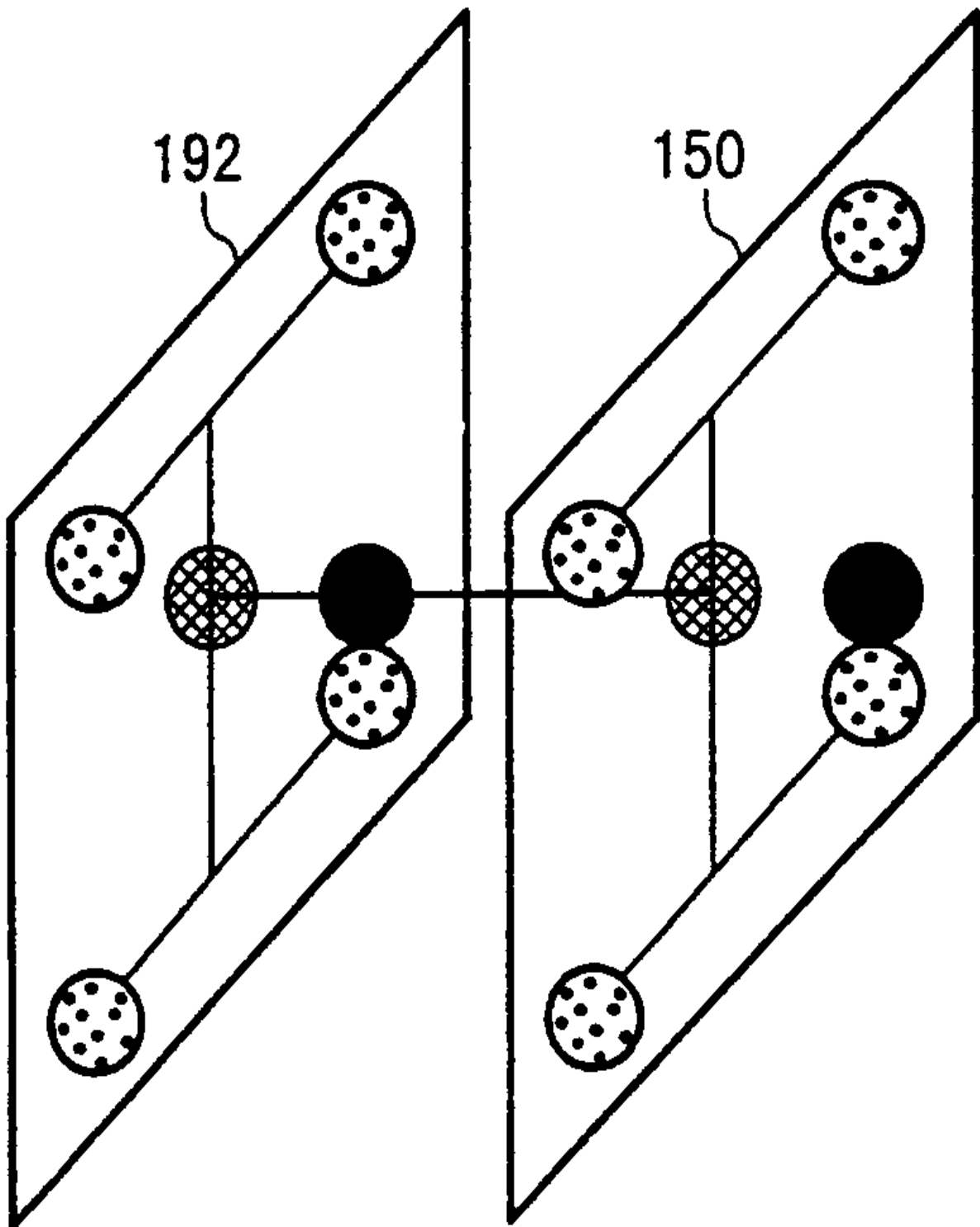

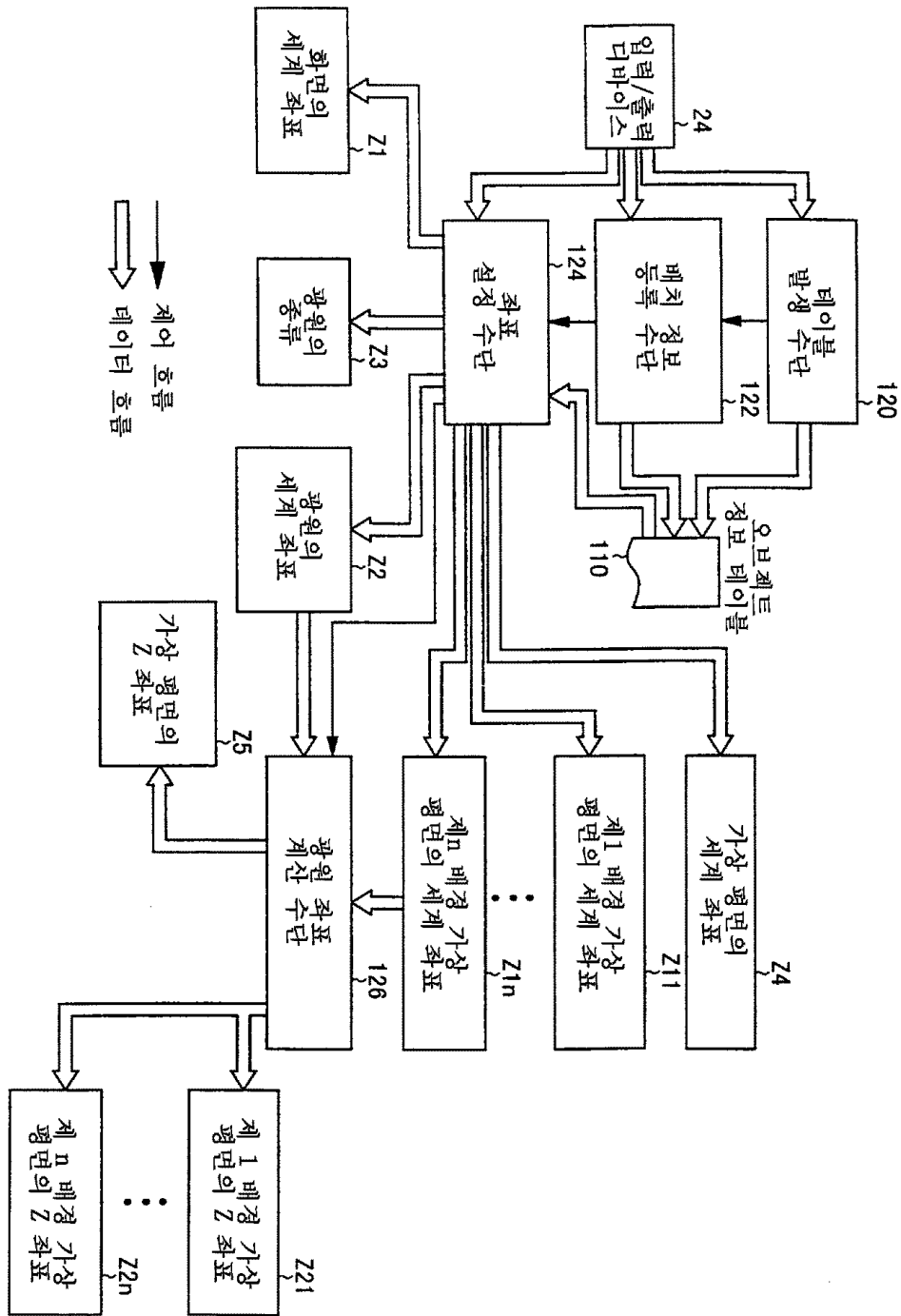

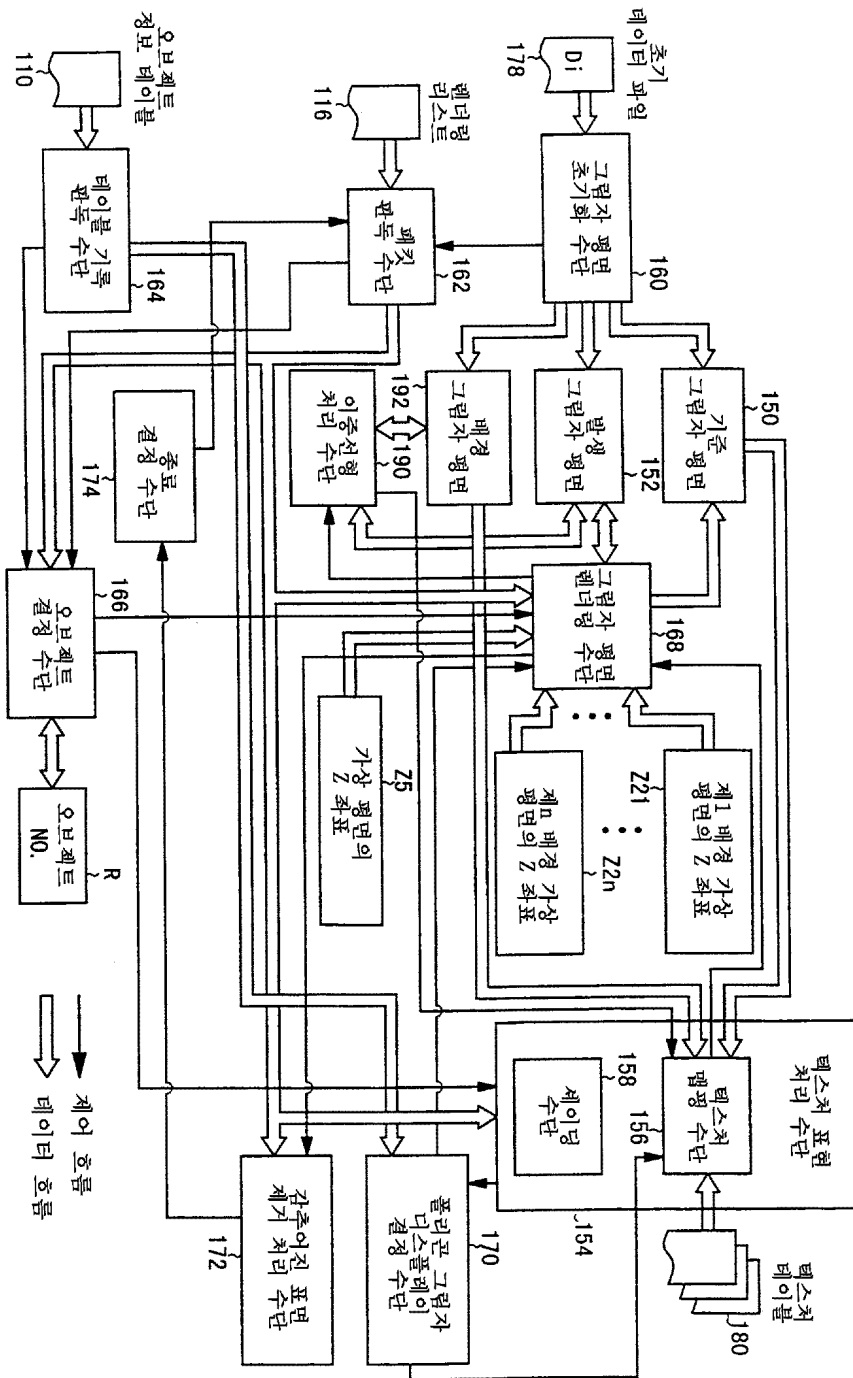

26

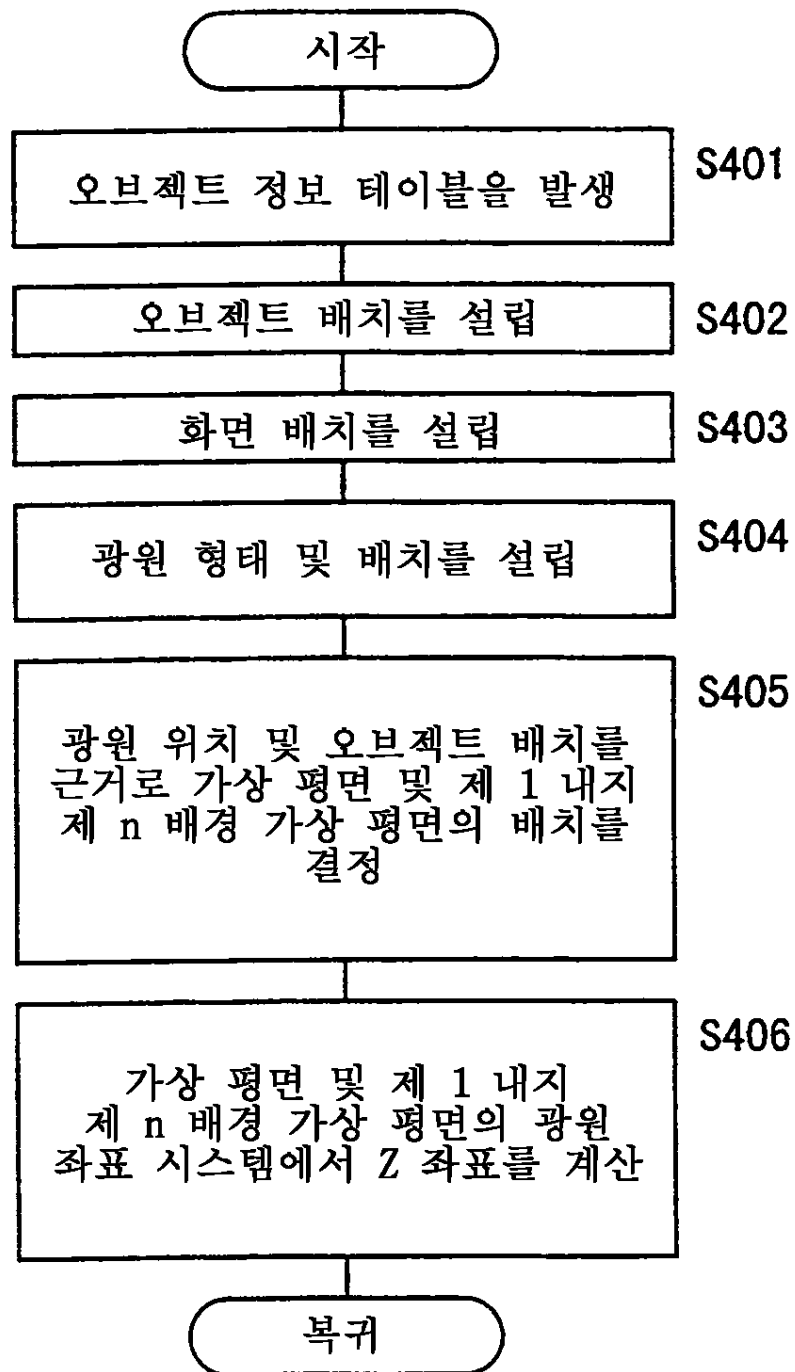

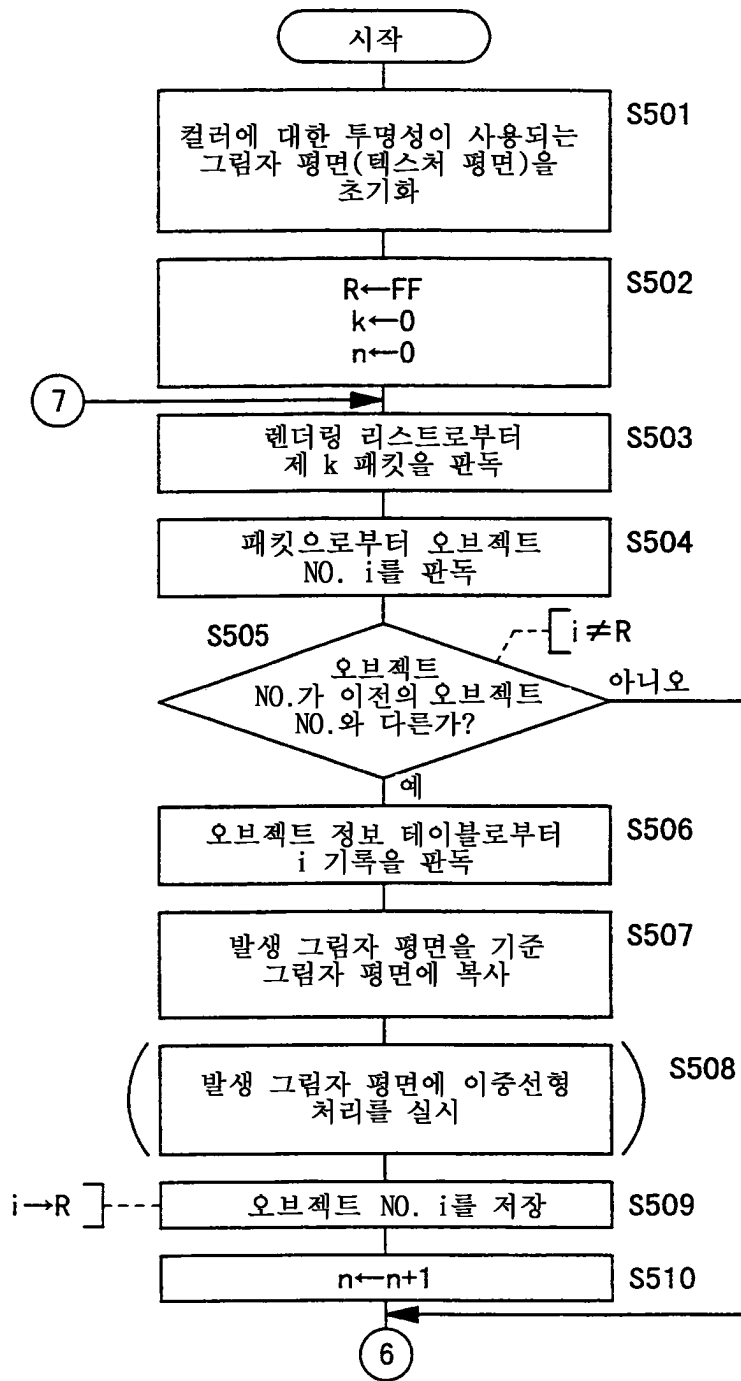

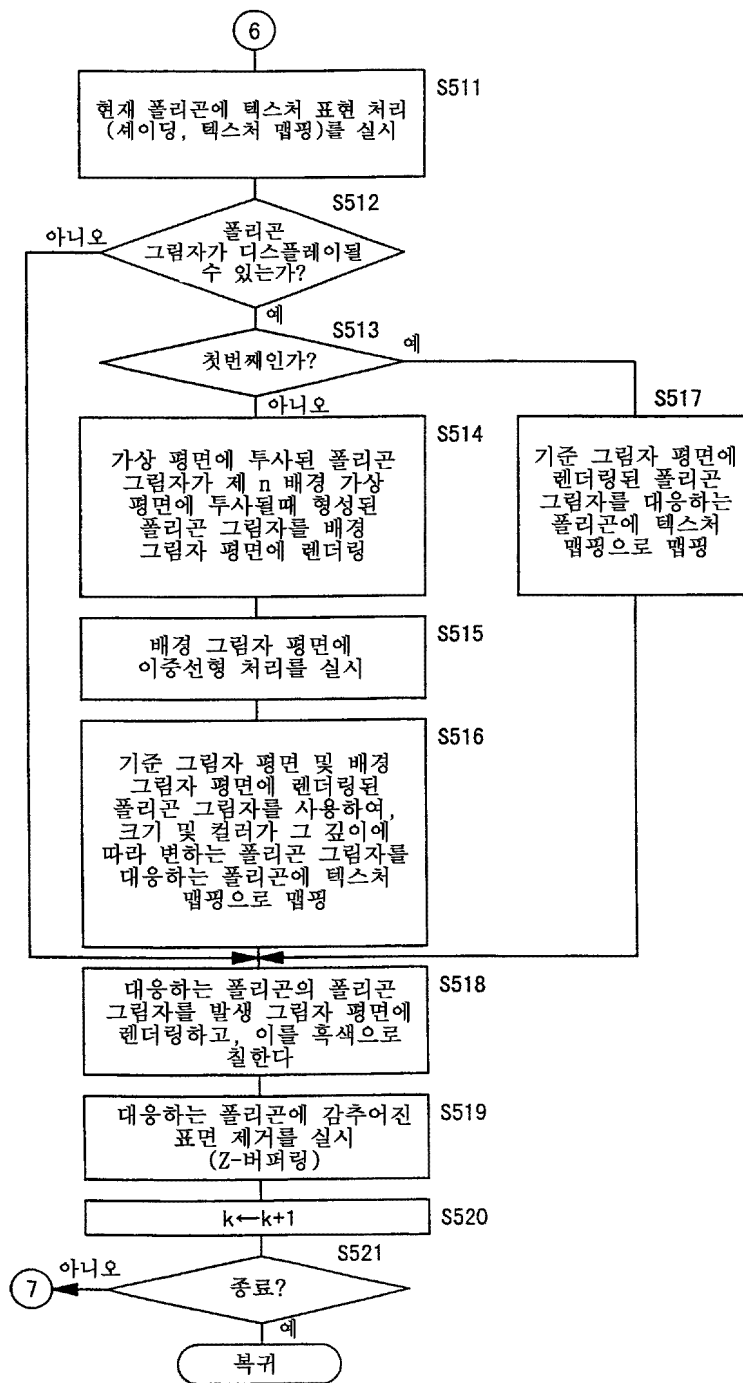

29

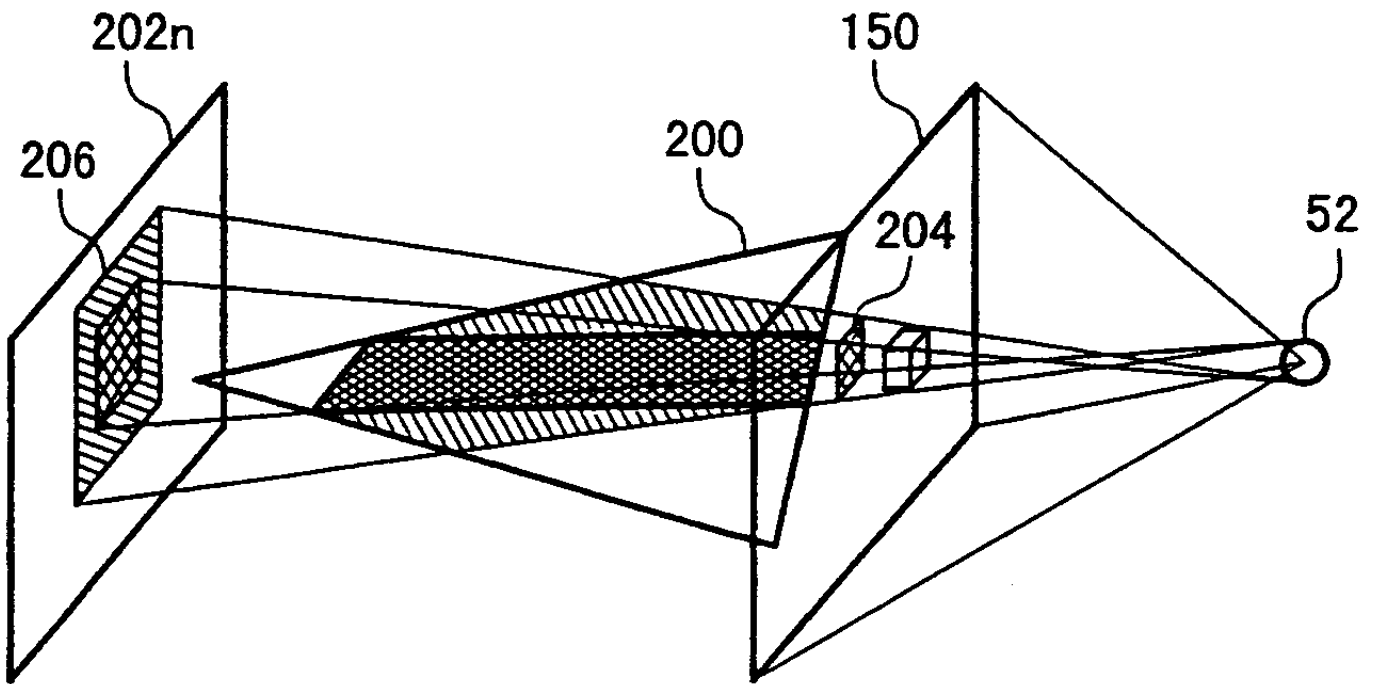

30

