

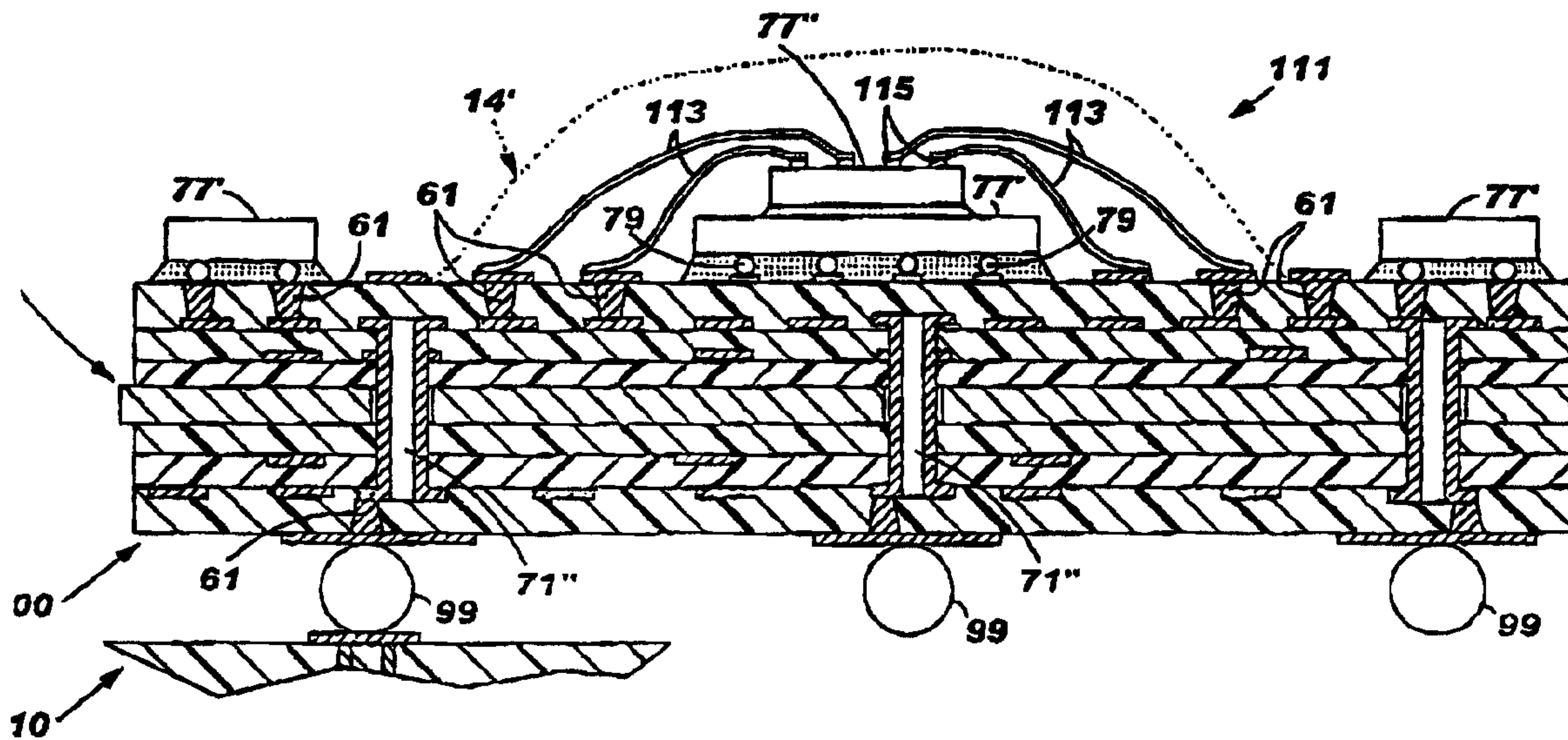

(22) Date de dépôt/Filing Date: 2004/01/09
(41) Mise à la disp. pub./Open to Public Insp.: 2004/07/30
(30) Priorités/Priorities: 2003/01/30 (10/354,000) US;
2003/03/24 (10/394,107) US; 2003/09/15 (10/661,616) US

(51) Cl.Int.⁷/Int.Cl.⁷ H01L 23/48, H01L 23/488, H01L 23/36,
H01L 23/29, H01L 25/00
(71) Demandeur/Applicant:
ENDICOTT INTERCONNECT TECHNOLOGIES, INC.,
US
(72) Inventeurs/Inventors:
FRALEY, LAWRENCE R., US;
MARKOVICH, VOYA, US
(74) Agent: SMART & BIGGAR

(54) Titre : MODULE ELECTRONIQUE A PUCES EMPILEES DOTE D'UN PORTE-PUCES STRATIFIE ET METHODE DE FABRICATION
(54) Title: STACKED CHIP ELECTRONIC PACKAGE HAVING LAMINATE CARRIER AND METHOD OF MAKING SAME



(57) Abrégé/Abstract:

A multi-chip electronic package which utilizes an organic, laminate chip carrier and a pair of semiconductor chips positioned on an upper surface of the carrier in a stacked orientation. The organic, laminate chip carrier is comprised of a plurality of conductive planes and dielectric layers and couples one or both of the chips to underlying conductors on the bottom surface thereof. The carrier may include a high-speed portion to assure high-frequency connection between the semiconductor chips and may also include an internal capacitor and/or thermally conductive member for enhanced operational capabilities. The first chip, e.g., an ASIC chip, is solder bonded to the carrier while the second chip, e.g., a memory chip, is secured to the first chip's upper surface and coupled to the carrier using a plurality of wirebond connections.

STACKED CHIP ELECTRONIC PACKAGE HAVING LAMINATE CARRIER
AND METHOD OF MAKING SAME

ABSTRACT

5

A multi-chip electronic package which utilizes an organic, laminate chip carrier and a pair of semiconductor chips positioned on an upper surface of the carrier in a stacked orientation. The organic, laminate chip carrier is comprised of a plurality of conductive planes and dielectric layers and couples one or both of the chips to underlying conductors on the bottom surface thereof. The carrier may include a high-speed portion to assure high-frequency connection between the semiconductor chips and may also include an internal capacitor and/or thermally conductive member for enhanced operational capabilities. The first chip, e.g., an ASIC chip, is solder bonded to the carrier while the second chip, e.g., a memory chip, is secured to the first chip's upper surface and coupled to the carrier using a plurality of wirebond connections.

15

STACKED CHIP ELECTRONIC PACKAGE HAVING LAMINATE CARRIER
AND METHOD OF MAKING SAME

Cross-Reference to Co-Pending Application

5

This application is a continuation-in-part of application S.N. 10/394,107, filed 3/24/03 and entitled "Multi-Chip Electronic Package Having Laminate Carrier" (inventors: L Fraley et al), which is a continuation-in-part of application S.N. 10/354,000, filed 1/30/03, and entitled, "High Speed Circuit Board And Method For Fabrication" (inventors: B. Chan et al).

10

Technical Field

The present invention relates, in general, to an electronic package for mounting of integrated circuits, and in particular, to an organic, multi-layered laminated interconnect structure for use in such a package.

15

Background Of The Invention

Organic laminate substrates, for example printed circuit boards and chip carriers, have been and continue to be developed for many applications. One such chip carrier is sold under the name HyperBGA by the assignee of this invention. (HyperBGA is a registered trademark of Endicott Interconnect Technologies, Inc.) These are expected to displace ceramic substrates in many chip carrier applications, because of reduced cost and enhanced electrical performance. The use of a multi-layered interconnect structure such as an organic, laminate chip carrier for interconnecting a semiconductor chip to a printed circuit board in an electronic package introduces many challenges, one of which is the reliability of the connection joints between the semiconductor chip and the organic chip carrier and another of which is the reliability of the connection joints between the organic chip carrier and the printed circuit board.

25

As semiconductor chip input/output (I/O) counts increase beyond the capability of peripheral lead devices and as the need for both semiconductor chip and printed circuit board miniaturization increases, area array interconnects are the preferred method for making large numbers of connections between a semiconductor chip and an organic chip carrier (such as the
 5 aforementioned HyperBGA chip carrier) and between the organic chip carrier and a printed circuit board. If the coefficient of thermal expansion (CTE) of the semiconductor chip, the organic chip carrier, and the printed circuit board are substantially different from one another, industry standard semiconductor chip array interconnections to the organic chip carrier can exhibit high stress during operation (thermal cycling). Similarly, the industry standard ball grid
 10 array (BGA) interconnections between the organic chip carrier and printed circuit board can also exhibit high stress during operation. Significant reliability concerns may then become manifest by failure of the connections or even failure of the integrity of the semiconductor chip (chip cracking). These reliability concerns significantly inhibit design flexibility. For example, semiconductor chip sizes may be limited or interconnect sizes, shapes and spacing may have to
 15 be customized beyond industry standards to reduce these stresses. These limitations may limit the electrical performance advantages of the organic electronic package or add significant cost to the electronic package. Typically a semiconductor chip has a CTE of 2-3 parts per million per degree Celsius (ppm/^o C.) while a standard printed circuit board has a much greater CTE of 17-20 ppm/^o C.

20 One example of an organic chip carrier designed to overcome such CTE and related problems is defined in U.S. Patent 6,351,393 (J.S. Kresge et al) which includes a specific thermal internally conductive layer designed to prevent failure between the single chip and the carrier solder connections, and those between the carrier and base substrate (e.g., PCB) on which it is
 25 positioned. This patent is incorporated herein by reference.

Other examples of various electronic packages such as the above are shown and described in the following documents:

	<u>U.S. Patents</u>		
30	4,882,454	11/1989	Peterson et al
	5,072,075	12/1991	Lee et al

	5,121,190	6/1992	Hsiao et al
	5,483,421	1/1996	Gedney et al
	5,615,087	3/1997	Wieloch
	5,661,089	8/1997	Wilson
5	5,798,563	8/1998	Fielchenfeld et al
	5,838,063	11/1998	Sylvester
	5,894,173	4/1999	Jacobs et al
	5,900,675	5/1999	Appelt et al
	5,926,377	7/1999	Nakao et al
10	5,982,630	11/1999	Bhatia

Foreign Patent Documents

15	JP	1-307294	12/1989
	JP	6-112271	4/1994
	JP	9-232376	9/1997
	JP	10-209347	8/1998
	JP	11-087560	3/1999
20	JP	2000-022071	1/2000
	JP	2000-024150	1/2000

In order to increase the operational characteristics of such modules, the addition of more than one chip to the upper surface of a chip substrate has been considered. However, due to the operating temperatures of such added chips, especially if placed in a closely spaced orientation, a much higher temperature compensating substrate material, ceramic, has usually been required, especially when the substrate having the chips is to be mounted on and coupled to an organic substrate such as a typical PCB. Examples are described in the following IBM Technical Disclosure Bulletins (TDBs):

	07/1978	Multi Chip Cooling Plate	pp 745-746
	02/1982	Simultaneous Chip Placement - Multi-Chip Modules	pp 4647-4649
	11/1987	High Performance Multi-Chip Module	pp 437-439
35	08/1988	Low-Cost, High-Power, Multi-Chip Module Design	pp 451-452
	09/1993	Thermally Conductive Substrate Mounted Multi-Chip Module Cap	pp 623-624

The use of ceramic, however, poses many problems, a primary one of which is handling. Ceramic is a relatively brittle material capable of cracking and chipping if handled improperly, especially during manufacture and shipping. Ceramic is also a relatively difficult material to

process, especially to the multi-depth level where several individual layers of insulative and interconnecting conductive materials are needed to satisfy many operational requirements.

Chip carriers of non-ceramic material have been proposed, but these typically possess
5 various drawbacks. In 5,574,630, for example, three chips are mounted on a substrate comprised
of silica-filled polytetrafluoroethylene (PTFE) but require individual vias to pass through the
carrier's entire thickness to connect to desired connections on the opposite side. Additionally,
this structure in turn mandates utilization of a complex "power/ground assembly" of several
layers having specific CTEs and other properties, thus resulting in a very expensive final
10 assembly and one that is relatively difficult to construct.

Yet another non-ceramic substrate embodiment for having more than one chip thereon is
described in 6,246,010. Unfortunately, the substrates described herein require semiconductor
chips which are extremely thin (less than 100 μm , preferably less than 50 μm , and "most
15 preferably" less than 20 μm). Understandably, such thinned chips are incapable of adequately
providing the much greater operational capabilities as required by today's more powerful chips
(e.g., those of the application specific integrated circuit (ASIC) variety). Typically, such chips
operate at much higher temperatures than other types (e.g., those of the dynamic random access
memory (DRAM) variety).

20 In grandparent pending application S.N. 10/354,000, cited above, there is defined a PCB
which is capable of providing high speed interconnections between two or more components
such as chips or modules (chip carriers) mounted thereon. This PCB is specifically designed to
accommodate the increased operational requirements for electronic structures such as electronic
25 modules which mount on the PCBs and are coupled together through the board's circuitry. One
particular increase that this PCB accommodates is the need for higher frequency connections
between the mounted components, which connections, as stated, occur through the underlying
host PCB. Such connections are subjected to the detrimental effects, e.g., signal deterioration,
caused by the inherent characteristics of such known PCB wiring. For example, signal
30 deterioration is expressed in terms of either the "rise time" or the "fall time" of the signal's

response to a step change. The deterioration of the signal can be quantified with the formula $(Z_0 * C)/2$, where Z_0 is the transmission line characteristic impedance, and C is the amount of the via capacitance. In a wire having a typical 50 ohm transmission line impedance, a plated through hole via having a capacitance of 4 pico farad (pf) would represent a 100 pico-second (ps) rise-time (or fall time) degradation, as compared to a 12.5 ps degradation with a 0.5 pf buried via of the present invention, as discussed below. This difference is significant in systems operation at 800 MHz or faster, where there are associated signal transition rates of 200 ps or faster.

A typical high performance PCB, prior to the ones defined in S.N. 10/354,000 and S.N. 10/394,107, has not been able to provide wiring densities beyond a certain point due to limitations imposed by the direct current (DC) resistance maximum in connections between components (especially chips). Similarly, high speed signals demand wider lines than normal PCB lines to minimize the "skin effect" losses in long lines. To produce a PCB with all wide lines would be impractical, primarily because of the resulting excessive thickness needed for the final board. Such increased thicknesses are obviously unacceptable from a design standpoint.

Various PCBs are described in the following documents:

U.S. Patents

20	4,902,610	02/1990	C. Shipley
	5,336,855	09/1994	J. Kahlert et al
	5,418,690	05/1995	R. Conn et al
	5,768,109	06/1998	J. Gulick et al
25	5,891,869	04/1999	S. Lociuro et al
	5,894,517	04/1999	J. Hutchison et al
	6,023,211	02/2000	J. Somei
	6,075,423	06/2000	G. Saunders
	6,081,430	06/2000	G. La Rue
30	6,146,202	11/2000	S. Ramey et al
	6,222,740	04/2001	K. Bovensiepen et al
	6,431,914	08/2002	T. Billman
	6,495,772	12/2002	D. Anstrom et al
35	US2002/0125967	09/2002	R. Garrett et al

Foreign Patent Document

JP4025155A2

01/1992

O. Takashi

5 The teachings of these documents are incorporated herein by reference.

The unique characteristics of the PCBs in S.N. 10/354,000 and S.N. 10/394,107 allow it to be able to assure high frequency connections while still utilizing relatively standard PCB manufacturing processes to produce the final structure. In these pending applications,
10 incorporated herein by reference, a portion of the PCB is dedicated to utilizing relatively wider lines than the remaining, lower portion of the PCB, which includes lines and spacings known in the PCB field.

The use of such a structure or the like or a similar substrate of a material other than
15 ceramic or not possessing the severe drawbacks of previous non-ceramic materials as mentioned above and which is capable of providing high speed or other effective coupling between two or more chips (especially high temperature chips such as ASIC chips) on one surface thereof as defined herein, yet which can then be directly electrically coupled to a second underlying substrate such as a typical PCB to also couple said chips to the PCB's circuitry, is believed to
20 constitute a significant advancement in the art.

Objects and Summary Of The Invention

It is, therefore, a primary object of the present invention to enhance the art of chip
25 carriers including more than one chip as part thereof, known in the ceramic substrate art also as multi-chip electronic packages (or modules).

It is another object of the invention to provide such a package which assures high speed connections between the chips thereon, while attaining effective electrical coupling with the
30 underlying circuitized substrate (e.g., PCB) on which one or more of the carriers of the invention may be mounted.

It is a further object of the invention to provide such a package which is capable of providing such connections for high temperature chips such as those of the ASIC variety, while assuring a minimum of substrate upper surface area is utilized.

5 It is still another object of the invention to provide such a package which can be produced in a cost effective manner while assuring a final structure of robust construction.

Further, it is another object of the invention to provide a package-substrate assembly utilizing the package of the invention as part thereof, the assembly thus benefiting from the
10 unique advantages of the multi-chip carrier defined herein.

Finally, it is an object of the invention to provide a method of making an electronic package including a chip carrier and plurality of chips mounted on one surface thereof, which method can be completed in a facile and relatively inexpensive manner, thus resulting in a final
15 end product of reduced cost.

According to one aspect of the invention, there is provided a multi-chip electronic package comprising an organic, laminate chip carrier including a plurality of electrically
conductive planes spacedly positioned therein and separated by respective layers of dielectric
20 material, the chip carrier including a plurality of electrical contacts on a first surface thereof and a plurality of electrical conductors on a second surface thereof, selected ones of the electrical contacts being electrically coupled to selected ones of the electrical conductors, and first and second semiconductor chips positioned on the first surface of the organic, laminate chip carrier in a stacked orientation, each semiconductor chip electrically coupled to selected ones of the
25 electrical contacts.

According to another aspect of the invention, there is provided a method of making a multi-chip package wherein the method comprises the steps of providing an organic, laminate chip carrier having first and second surfaces and including a plurality of electrically conductive
30 planes spacedly positioned therein and separated by respective layers of dielectric material,

providing a plurality of electrical contacts on the first surface of the organic, laminate chip carrier, providing a plurality of electrical conductors on the second surface of the organic, laminate chip carrier, selected ones of the electrical contacts being electrically coupled to selected ones of the electrical conductors, and positioning first and second semiconductor chips on the first surface of the organic, laminate chip carrier in a stacked orientation and electronically coupling the first and second semiconductor chips to the selected ones of the electrical contacts.

According to a third aspect of the invention, there is provided an electronic package assembly which includes a circuitized substrate including a plurality of electrically conductive members thereon, an organic laminate chip carrier including a plurality of electrically conductive planes spacedly positioned therein and separated by respective layers of dielectric material, the chip carrier including a plurality of electrical contacts on a first surface thereof and a plurality of electrical conductors on a second surface thereof, selected ones of the electrical contacts being electrically coupled to selected ones of the electrical conductors, first and second semiconductor chips spacedly positioned on the first surface of the organic, laminate chip carrier in a stacked orientation and electrically coupled to selected ones of the electrical contacts, and a plurality of electrically conductive elements electrically connecting the selected ones of the electrical conductors on the second surface of the organic, laminate chip carrier to respective ones of the electrically conductive members on the circuitized substrate.

20

Brief Description Of The Drawings

FIG. 1 is a side-elevational view, partly in section, illustrating the multi-chip electronic package of S.N. 10/394,107;

25

FIG. 2 is a side-elevational view of the package of FIG. 1 further including a quantity of encapsulant and a cover member thereon;

30

FIG. 3 is an alternative embodiment of the package of FIG. 1, illustrating the use of a stiffener member and cover and heat sinking member as part thereof;

FIG. 4 is a side-elevational view illustrating an alternative embodiment of the package of S.N. 10/394,107;

5 FIG. 5 is a perspective view of an information handling system adapted for using one or more of the multi-chip electronic packages of the instant invention and/or the complete assemblies (including an underlying PCB) therein;

10 FIG. 6 is a side-elevational view, in section, of one portion of an organic, laminate chip carrier which, when combined with at least one other portion, may be used as the chip carrier for the instant invention;

FIG. 7 is a side-elevational view, in section, of another portion of a laminate chip carrier;

15 FIG. 8 is an assembled, elevational view, in section, illustrating an organic, laminate chip carrier which can be used in the instant invention;

FIG. 9 is another embodiment of an organic, laminate chip carrier which may be used in the instant invention;

20 FIG. 10 represents another aspect of a multilayered laminate chip carrier capable of being used in the instant invention;

25 FIG. 11 represents a side-elevational view, in section, of yet another embodiment of an organic chip carrier usable in the present invention;

FIG. 12 is a top plan view of a circuit pattern that may be used on the organic, laminate chip carrier of the present invention;

FIG. 13 is a side-elevational view, as taken along the line 8-8 in FIG. 12. It is understood that the embodiment of FIG. 13 represents only a portion of the organic, laminate chip carrier capable of being used in the present invention.

5 FIG. 14 is an enlarged, side elevational view, partly in section, of an electronic package according to one embodiment of the invention; and

FIG. 15 is a much enlarged, partial side elevational view of a stacked chip arrangement according to an alternative embodiment of the invention.

10

Best Mode for Carrying Out the Invention

For a better understanding of the present invention, together with other and further objects, advantages and capabilities thereof, reference is made to the following disclosure and
15 appended claims in connection with the above-described drawings. It is understood that like numerals will be used to indicate like elements from FIG. to FIG.

As stated above, the term "high speed" as used herein is meant signals of high frequency. Examples of such signal frequencies attainable for the multilayered chip carriers and circuitized
20 substrates (e.g., PCBs) defined herein and as produced using the methods taught herein include those within the range of from about 3.0 to about 10.0 gigabits per second (GPS). These examples are not meant to limit this invention, however, because frequencies outside this range, including those higher, are attainable. As further understood from the following, the carrier products produced herein may be formed of at least two separate multilayered portions
25 (subassemblies) which have themselves been formed prior to bonding to each other. At a minimum, each of these separate portions will include at least one dielectric layer and one conductive layer, with most likely embodiments including several layers of each as part thereof. Examples are provided below and are just that (only examples) and the numbers of layers shown and described are not meant to limit the scope of this invention.

30

The products as defined herein are particularly adapted for use in what can be termed "information handling systems". By the term "information handling system" as used herein shall mean any instrumentality or aggregate of instrumentalities primarily designed to compute, classify, process, transmit, receive, retrieve, originate, switch, store, display, manifest, measure, detect, record, reproduce, handle or utilize any form of information, intelligence or data for business, scientific, control or other purposes. Examples include personal computers and larger processors such as servers, mainframes, etc. An example is shown in FIG. 5, as a server, and is seen to include at least one multi-chip package and a circuitized substrate having the package mounted thereon within the server's housing.

In FIG. 1, there is shown the multi-chip electronic package 1 of S.N. 10/394,107, the package comprising an organic, laminate chip carrier 2 and a plurality of semiconductor chips 3 located on the carrier. Organic, laminate chip carrier 2, which can function as the carrier for the present invention, includes a plurality of conductive planes 4 spacedly positioned within the carrier and separated by respective layers of dielectric material 5. Carrier 2 further includes a plurality of electrical contacts 6 (one shown) on the carrier's upper surface, each contact in turn designed for being electrically coupled to a respective conductive member (e.g., a solder ball 7) which in turn couples the contact to a corresponding contact site (not shown) on the undersurface of chip 3. Such chip sites are well known and further description is not believed necessary. Each of the chips 3 is coupled through the internal circuitry of carrier 2 to respective ones of electrical conductors 8 (only one shown) which in turn are capable of being electrically coupled (i.e., utilizing a plurality of solder balls 9 to respective contact sites (not shown) on an underlying circuitized substrate 10, a primary example being a multi-layered PCB. Chips 3, using the circuitry on the upper surface of carrier 2 and possibly portions thereof within the carrier, may be electrically coupled to one another depending on the operational requirements for the final product. As further seen in FIG. 1, the individual contacts 6 do not necessarily directly couple to a respective conductor by a linear (here, vertical) connection such as a plated through hole extending from the top of the carrier through the entire thickness thereof. This carrier, in such simplified form, may comprise the carrier for the present invention.

In FIG. 1, both chips, unlike those of the present invention, occupy a substantially coplanar orientation on the upper surface of carrier 2 and are spaced apart from one another. In one example, each chip may possess length and width dimensions of about 10 mils and 20 mils, respectively, and may be coupled to the carrier using a plurality of solder balls 7 having a number within the range of from about 1,000 to about 3,000. It is understood that the carrier of FIG. 1, and the one of the present invention, is not limited to these dimensions or numbers and that others are readily acceptable. Each chip for the FIG. 1 (S.N. 10/394,107) may be an ASIC chip or other type, depending on product operational requirements.

In one embodiment, carrier 2 includes an upper, high-speed portion 11 and a lower portion 12 in which signals pass at lower frequencies. A more specific example of this particular construction will be defined hereinbelow. The dielectric material for carrier 2 may be selected from a variety of known PCB dielectric materials, including known fiberglass-reinforced epoxy resin, Driclad (a registered trademark of the assignee of this invention), PTFE, Nelco 6000SI, Rogers 4300, Polyclad LD621 (see below), etc. Therefore, it does not necessarily need to be comprised of PTFE. It is also possible that carrier 2, if used in the present invention (FIGS. 13,14), may include a thermally conductive member 13 therein. If so utilized, the thermally conductive member 13 may be comprised of a material having a selected thickness and coefficient of thermal expansion to substantially prevent failure of the solder connections provided by solder balls 7 and 9. Thermally conductive member 13 can be a suitable metal comprised of nickel, copper, molybdenum, or iron. Preferably, the thermally conductive layer also functions as a ground plane. The preferred thermally conductive member (which has a CTE of close to zero) is a three layered structure comprised of a first, outer layer of copper, a second, interim layer of an alloy of about 34% to about 38% nickel (preferably about 36% nickel) and about 62% to about 66% iron (preferably about 63% iron), and a third, outer layer of copper. The overall CTE of thermally conductive member 13 is from about 4 to about 8 ppm/ $^{\circ}$ C. Preferably, about 72% to about 80% of the thickness of the thermally conductive layer is the nickel-iron alloy and about 20% to about 28% of the thickness of the thermally conductive layer is copper. A suitable 36% nickel-63% iron alloy is available from Texas Instruments Incorporated (Attleboro, Massachusetts). Alternatively, the thermally conductive member can be

formed solely of a single metal alloy such as about 36% nickel-about 63% iron alloy. The thickness of the thermally conductive member is preferably from only about 1 mil to about 3 mils. The thickness and choice of material for the member will determine the CTE of the member and, significantly, can be used to control the CTE of the multi-layered chip carrier when used in combination with the other elements defined herein. When the overall CTE of the multi-layered interconnect structure is controlled to a value of about 10 to about 12 ppm/° C., a significant advantage is achieved. Strain control on the solder connections is realized and localized regions of high strain are avoided during operation of the package (when assembled to a circuitized substrate and in field operation), an important feature if two or more chips are used and in close proximity to one another. The overall strain between the semiconductor chips 12, with a CTE of about 2-3 ppm/° C., and the circuitized substrate, with a CTE of about 17-20 ppm/° C., is thus significantly reduced in magnitude. Further description of this member is provided in U.S. Patent 6,351,393, incorporated herein by reference. Carrier 2 is thus an excellent component for use with the present invention.

Chip carrier 2 may also include an internal capacitor structure therein, such as described in U.S. Patent 6,370,012, also incorporated herein by reference. As defined therein, the capacitor structure is a parallel capacitor suitable for use in chip carriers or the like designed for being positioned on an underlying substrate such as a PCB. In the structure of 6,370,012, the capacitor preferably includes at least one internal conductive layer, two additional conductor layers added on opposite sides of the internal conductor and inorganic dielectric material (preferably an oxide layer) on the second conductor layer's outer surfaces. Alternatively, a suitable dielectric material such as berium titanate applied to the second conductive layer may be utilized. Further, the capacitor in this cited patent includes outer conductor layers atop the inorganic dielectric material to thus form a parallel capacitor between the internal and added conductive layers and the outer conductors. Further description is found in 6,370,012.

In FIG. 2, the package 1 of FIG. 1 is shown to further include a quantity of encapsulant material 14 (in phantom) which lies on the upper surface of carrier 2 and substantially surrounds the semiconductor chips 3, including the underlying solder ball connections 7. Such encapsulant

can be used in the present invention shown in FIGS. 14 and 15. Encapsulant materials are known in the packaging art and further description is not believed necessary. Suitable examples can be found in one more of the documents cited hereinabove. Package 1 in FIG. 2 is also shown to include a heat sinking cover member 15 (also in phantom) which lies atop the formed
5 encapsulant and in thermal contact with the upper surfaces of the semiconductor chips 3. Member 15, also usable in the present invention, thus serves to facilitate heat removal from the chips during operation thereof. In one example, cover member 15 is preferably of copper, but may also be aluminum or other sound, thermally conductive material.

10 In FIG. 3, package 11 is shown as including a stiffener member 16 (in phantom) which rests atop the upper surface of carrier 2 and substantially surrounds the spacedly positioned chips and is also spaced therefrom. The stiffener member further includes a heat-sinking cover member 17 (in phantom) located on an upper surface thereof and a heat-sinking member 18, in phantom, located thereon. Stiffener 16 is preferably of stainless steel material while
15 heat-sinking cover member 17 is preferably copper or aluminum and the heat-sinking member 18 preferably aluminum and including a plurality of upward projections as shown in FIG. 3. The heat-sinking cover member 17 is designed for receiving heat from chips 3 to in turn pass the heat through to the larger heat-sinking member 18 to thus facilitate thermal removal from package 11 during operation thereof. This arrangement, like encapsulant 14, is also usable in the present
20 invention of FIGS. 14 and 15.

The above heat-sinking components serve to effectively remove the relatively high heat as produced by powerful chips such as those of the ASIC variety, as described above. The additional use of the internal thermally conductive member further assures an effective operating
25 product which will not disrupt or result in damage to the relatively delicate solder connections formed both between the chip and carrier and, if utilized, between the carrier and underlying substrate.

In FIG. 4 there is shown an alternative embodiment of an electronic package 1' defined in
30 S.N. 10/394,107. Package 1' includes a carrier 2 similar to that described above and preferably

utilizes solder elements 9 or the like to couple the carrier to the underlying substrate 10. Package 1' differs from package 1 in FIGS. 1-4, however, by the utilization of substantially vertically oriented chips 3' (unlike those taught in FIGS. 14 and 15) which are preferably electrically coupled to respective contacts 6 on the carrier's upper surface by respective solder balls 7'.

5 Chips 3' are also preferably oriented substantially parallel to one another and, as understood, possess a width (or length) dimension extending into the page from the viewer's viewpoint. These chips may include surface contact sites similar to those in FIG. 1 with appropriate circuitry extending to the outer (lower) edge thereof such that connections using solder balls 7' can occur. Chip carrier 2, like that in FIGS. 1-4, may also include an internal thermally conductive member
10 (not shown) and/or capacitor (not shown) as described hereinabove.

The embodiment of FIG. 4 may also include encapsulant material and a heat-sinking cover member such as shown in FIG. 2, or, alternatively, a stiffener, heat-sinking cover and heat-sink member as shown in FIG. 3. Further description is thus not believed necessary.

15

In FIG. 5, there is shown an information handling system 19 in which the subject invention of FIGS. 14 and 15 may be utilized. By way of example, system 19 may be a server (as shown), a personal computer, mainframe or similar information handling system known in the art. It is well-known in the information handling systems art that these structures include
20 circuit boards and electronic packages as part thereof. In the instant invention, system 19 is shown to include a circuitized substrate 10 (in phantom) having the multi-chip electronic package 101 of FIG. 14 (or FIG. 15) thereon. The positioning relationship of the substrate and package is for illustration purposes only in that this assembly can also be located at other locations within system 19, including substantially perpendicular to the orientation shown. It is
25 also understood that several such assemblies may be utilized in such a system, depending on the operational requirements thereof. If the system is a computer, server, mainframe or the like, it will include a central processing unit (CPU), one or more input/output (I/O) devices, and one or more random access storage devices. It may also include various peripheral devices functionally operable therewith, including keyboards, mice, displays, printers, speakers and modems. The

components, including positioning thereof within or in operational relationship to a computer, server, mainframe, etc., are well known in the art and further description not deemed necessary.

In FIGS. 6 and 7, there are shown two embodiments of multilayered portions 20 and 20',
5 usable in the substrate of the invention. Portions 20 and 20', when bonded to another multilayered portion, may form the chip carrier according to one embodiment of the invention. Accordingly, portions 20 and 20' will be defined herein as second portions while the other portion will be referred to as the first (or base) portion. It is to be understood that in accordance with the broad aspects of this invention, at least one second portion is to be bonded to at least one
10 first portion such that this second portion lies substantially along the external portions of the final carrier product. It is also understood that one or more of such second portions may be bonded to the base, first portion, including on opposite sides thereof such as depicted in FIGS. 8-11. Most significantly, the second portions as defined herein are specifically designed for providing high frequency (high speed) connections between semiconductor chips mounted (e.g., soldered) to the
15 second portions and/or otherwise electrically coupled thereto. Importantly, the first or base portion will not necessarily require such capability but instead can be formed in the regular manner for most current PCBs, many of which are described in the above-listed documents. This thus allows the utilization of known PCB manufacturing techniques to produce a resulting chip carrier with significantly increased capability such that chips secured thereto can be
20 connected at higher speeds than heretofore attainable. Such connections are considered essential in the rapidly expanding packaging art, due primarily to the corresponding increased requirements of such components. The present invention as defined herein thus provides a significant advancement in the art.

25 In FIG. 6, multilayered portion 20 is shown as including a central conducting plane 21 which, in a preferred embodiment, serves as a power plane. Plane 21 is surrounded by two layers of dielectric material 23, shown in the drawing as one continuous structure due to the bonding (lamination) of both layers onto plane 21. On the external surfaces of dielectric material 23 are located additional conductive planes 25 and 27, which in a preferred embodiment of the
30 invention (if portion 20 is to be used) comprise a series of signal lines. Portion 20 can thus be

5 simply referred to as a 2S1P structure, meaning it comprises two signal planes and one power plane. A conductive through hole 29 is also provided to connect the upper signal plane 25 with lower plane 27. In a preferred embodiment, the conductive through hole is a plated through hole (PTH), produced using known technologies. The formation of portion 20 is accomplished using known PCB procedures, including lamination of the aforementioned dielectric layers and deposition (e.g., plating) of the external signal planes. Further process description is thus not believed necessary.

10 As mentioned, portion 20 is designed for providing high speed (high frequency) connections between chips located on the upper surface of the carrier's substrate and coupled thereto when portion 20 is formed in combination with another multilayered portion to form a final carrier. In order to provide such high speed connections, therefore, the individual signal lines in portion 20 (and 20') preferably possess a width of from about 0.005 inch to about 0.010 inch and a thickness of 0.0010 to about 0.0020 inch. The corresponding dielectric layers each possess a thickness of from about 0.008 inch to about 0.010 inch. The material for planes 21, 25 and 27 is preferably copper, but other conductive materials are possible. The preferred dielectric material 23 is a low loss dielectric, one example being Polyclad LD621, available from Cookson Electronics, located in West Franklin, New Hampshire. Additional materials include Nelco 6000SI, available from Park Nelco, located in Newburgh, New York and Rogers 4300, available from Rogers Corporation, located in Rogers, Connecticut. These materials have a low dielectric constant and loss factor to provide the optimum operational capabilities for the structure. Other materials possessing dielectric loss ≤ 0.01 , and preferably less than $< .005$ would be suitable for use in both portions 20 and 20'. Again, this dielectric material need not be PTFE.

25 It is understood that the above thicknesses and defined materials are not meant to limit the scope of this invention, in that others are possible while attaining the desired results taught herein. It is also understood that the second portion of this structure, if used, can include the aforedefined thermally conductive member and/or internal capacitor structure therein. In one example, using the aforementioned thicknesses, widths and materials, it was possible to provide a second portion 20 (and 20') capable of passing signals at a signal frequency within the range of

30

from about 3 to about 10 GPS. This is also not meant to limit the invention in that higher frequencies, e.g., 12 GPS, are possible with relatively insignificant modification to one or more of the above materials, parameters, etc. The resulting overall thickness for portion 20 as defined, according to one embodiment, is about 0.140 inch.

5

Although it is not a necessary requirement, the aforementioned widths and thicknesses for the conductive planes and dielectric layers will normally be thicker than those for the base or first multilayered portion to which portions 20 and 20' will be bonded. That is, the base portions will typically include much less thickness and width dimensions for the conductive planes and dielectrics used therein, such widths, thicknesses and materials being typical of those of known PCB structures used today. Thus, further description will not be necessary.

FIG. 8 illustrates an embodiment of a chip carrier 30, also usable in the present invention, in which two second portions 20 are utilized, each of these portions located on opposite sides of a common first multilayered portion 31. First portion 31 is illustrated, for simplification purposes, as a singular dielectric layer including outer conductive layers 33 and 35 thereon. In one embodiment, layers 33 and 35 are power or ground planes, depending on the operational requirements of the final board 30. In a preferred embodiment, portion 31 will include several (e.g., twenty) conductive planes therein of mixed signal and ground and/or power capabilities and a corresponding plurality (e.g., nineteen) of dielectric layers. In its simplest form, portion 31 (and 31' in FIGS. 9-11) will include at least one signal plane passing signals therealong at a first frequency. As indicated earlier, both conductive planes and dielectric layers used in the first multilayered portion 31 are typically those utilized in a conventional PCB. Therefore, in one example, portion 31 may include conductive signal lines having widths of about 0.003 inch to about 0.010 inch and corresponding thicknesses of 0.0005 inch. The dielectric layers each include an initial thickness of about 0.010 inch. First portion 31, being of such multilayered construction, is laminated together to bond the several conductive dielectric layers to form the first portion 31. Additionally, second portions 20 are similarly formed as separate, multilayered subassemblies as described above. In the next step, a dielectric layer 41 (e.g., conventional prepreg or thermoplastic material) is added to opposite sides of the interim first portion 31 and

another dielectric layer 43 is added to each of the outermost surfaces of portions 20. This structure is now laminated to form a singular, multilayered organic chip carrier, using standard lamination processing, for use in the present invention. Because of the structural characteristics explained above and herein, at least some of the signal planes in second portions 20 and 20' will provide higher frequency signal passage than at least some of the signal lines in the conventional first portions 31 and 31'. In a preferred embodiment, all signal lines in the external portions will possess such superior capabilities compared to the signal layers of the first portions these are bonded to.

To access one or more of the outer conductive planes on each portion 20, openings 45 are provided within the outer dielectric layers 43. This is preferably done by laser or photoprinting operations known in the art. Following removal of the dielectric material, an outer conductive layer 51 is added on opposite sides of the structure in FIG. 8, including within the openings in the dielectric. At this point, connections for components are provided on carrier 30 that couple to the signal lines of portions 20 which in turn will assure high speed signal passage along these signal lines, including those on the upper and lower surfaces of each portion 20, to the second chip (not shown in FIG. 8) also coupled to the circuitry of the same portion 20, e.g., at a site to the left of the viewer in FIG. 8. Such connection would also be provided through an opening in conductive material 51 as shown in FIG. 8.

It is understood in FIG. 8 that two or more semiconductor chips, as shown in FIGS. 14 and 15, can be mounted on each of the opposite sides of carrier 30 and coupled together with high frequency signals, should the carrier include a modified lower surface or other means to couple it to PCB 10 (i.e., FIG. 1). The carrier of the present invention is thus able to uniquely couple two or more chips on opposite surfaces thereof to assure a finished chip carrier assembly possessing far greater operational capabilities than heretofore known in the art. (In a typical embodiment, however, carrier 30 will only include one upper high speed portion and one lower speed portion, the latter including bottom conductors such as shown in FIG. 14.)

For additional coupling, another layer of dielectric material 55 may also be added to cover the conductive planes 51, in which case, connection to the conductive material 51 within

opening 45 would be accomplished by a similar opening and conductive material 61 in FIG. 8 to electrically couple chips on one side of carrier 30. A plated through hole (PTH) 71 may be utilized to extend through the entire thickness of carrier 30, as illustrated to the right in FIG. 8. Such a through hole could be formed using conventional techniques and would include, e.g., a thin plated layer of conductive material (e.g., copper) on the surfaces thereof. This through hole may also be used to accept a conductive pin or the like if such an added component is desired. PTH 71 can also couple one or more components to internal conductive planes in the carrier's base or first portion 31.

10 In FIG. 8, the single semiconductor chip shown coupled to the conductive material 61 (or, alternatively, directly to material 51 should material 61 not be utilized) is represented by the numeral 77 and the connecting solder ball by the numeral 79 (not 7 as in FIG. 1).

15 Returning to FIG. 7, the portion 20' includes similar components to those of portion 20 in FIG. 6 but represents an alternative embodiment for forming a multilayered carrier using the teachings herein. Portion 20' includes as part thereof the 2S1P portion 20 therein. Dielectric layers 81 are added on opposite surfaces of portion 20, following which conductive layers 83 are then applied, e.g., via plating. The conductive layers 83 are preferably ground or power planes and are coupled together by a plated through hole 85 as shown. Like portion 20, several such through holes are utilized in the second portions to provide such connections. Only one is shown in both FIGS. 6 and 7 for illustration purposes. Dielectric layers 81 are preferably of similar material as the low loss dielectric layers used in portion 20. The layers of portion 20', like portion 20, are assembled using conventional lamination processing.

25 In FIG. 9, two second portions 20' are shown bonded to a common, interim multilayered first portion 31' which, in one embodiment and as stated above, includes several internal conductive planes (not shown) bonded by a corresponding number of individual dielectric layers (also not shown). The embodiment of FIG. 7 thus represents a simpler means of producing a final carrier (30' in FIG. 9) because of the fewer lamination steps necessary during the final bonding operations. That is, it is only necessary to laminate the three previously formed

30

multilayered structures 20' and 31' shown in FIG. 9. Again, it is noteworthy, and, most likely, that only one outer portion 20' will be bonded to an underlying conventional portion 31' in accordance with the teachings herein. Following complete lamination, an outer dielectric layer 55' may be added to the structure and a conductive opening 51' provided therein using similar techniques to those defined for providing the opening 45 and conductive material 51 in FIG. 8. A plated through hole 85 will couple any chip joined to material 51' to the top and/or bottom layers of portion 20', if desired. To couple the outermost surfaces of carrier 30', a common through hole 71' is provided, similarly to through hole 71 in FIG. 8. Such a through hole would preferably include the plated conductive material 73' similar to that in FIG. 8.

10

Of further significance, the through holes 71 and 71' can be used to electrically couple one or more of the chips to the internal wiring of the first multilayered portions 31 and 31', respectively, thus providing a direct electrical connection between these components and the interim structure. Thus, the carrier defined herein may provide the unique capability of assuring coupling between chips on one side of the carrier in addition to coupling of these same chips to internal conductive planes of the base or first portion of the carrier's overall structure. Such dual coupling represents a significant aspect of the invention because it results in a final carrier product having greater operational capabilities than heretofore known products.

15

20

In FIGS. 10 and 11, there are shown two alternative carrier embodiments 30" and 30"', respectively, that can be used in the present invention. The structure of carrier 30" in FIG. 10 is similar to that shown in FIG. 9 with the addition of a conductive through hole 91 extending from an outer surface of the carrier to one of the conductive planes of portion 20'. Coupling of a pinned component (i.e., the pin 93 shown in FIGS. 10 and 11) is thus also possible, in addition to the aforedefined coupling of additional electronic components. In the embodiment of FIG. 11, an elongated opening 95 is provided through the portion 31' (and the lower portion 20', if used). The reason for providing opening 95 is to provide proper clearance for inserting pin 93. Opening 95 can be preformed (drilled) on 31' and 20' (if used) before final lamination, contrasting to the conventional method of "back drilling" in order to eliminate the unused portion of the PTH.

25

30

Back drilling removes a portion of the PTH layer of copper. This reduces the capacitive effects

of the PTH when dealing with high speed signals. Back drilling is expensive and difficult to perform. The construction provided negates the need for back drilling and achieves the same effects.

5 FIGS. 12 and 13 represent another embodiment of a second portion 20" which can be used in the carrier of the invention. Understandably, FIG. 13 is a sectional view taken along the line 8-8 in FIG. 12 and serves to illustrate one embodiment of the respective widths of
10 conductors on the upper surface of portion 20". The through holes located at respective ends of the broader width conductors are also shown. In this arrangement, the broader width conductors
15 101 serve as signal lines to interconnect plated through holes 103 at the opposite ends thereof. In comparison, the narrower width signal lines 105 extend in paired relationship between the respective outer pairs of the wider lines 101. In one embodiment, lines 101 may possess a width of from about 0.003 inch to about 0.010 inch while the corresponding internal, narrower lines each may possess a width of 0.02 inch to about 0.10. These lines were spaced apart a distance of
20 from about 0.03 inch to about 0.10 inch. The purpose of providing the greater width lines 101 on opposite sides of the paired narrower signal lines 105 is to provide proper trace impedance control as well as signal shielding to minimize noise coupling amongst signal lines. As seen in FIG. 13, these lines are positioned on opposite sides of portion 20", with the narrower lines 105 located externally of an interim conductive (e.g., power) plane 106 coupled to the center PTH
25 103. This arrangement provides the advantageous feature of a continuous reference plane that can provide maximum signal shielding. This provides for simpler construction of subcomposites and also allows for sections with Z connections that can have different dielectric thicknesses; for example, fast signals vs. slower signals. Although such a pattern is shown, however, it is understood that in a preferred embodiment of the invention, each of the solder balls 79 (FIG. 14)
will be coupled to a singular contact arranged in a pattern similar to the pattern of the balls immediately under the chip. The above pattern may be used to interconnect respective balls on one chip to another chip, when the chips are oriented in the specific orientation according to preferred embodiments of the invention (see more below).

In FIG. 14, there is shown a multi-chip electronic package 111 according to one embodiment of the invention. Package 111 includes an organic, laminate chip carrier 300 including therein a plurality of electrically conductive planes spacedly positioned and separated by respective layers of dielectric material, similar to the structures defined hereinabove. Carrier 300 may also include the aforementioned thermally conductive member 13 substantially essentially positioned therein, in addition to a plurality of conductive plated through holes 71" for connecting respective opposed layers of conductors, e.g., signal planes. Conductive material 61 is also utilized within provided openings located within the upper outer surface layer of the carrier and, if desired, also within the lower, opposing outer surface area to connect the relatively large solder ball conductors 99 which, as shown, electrically couple the package to the lower circuitized substrate PCB 10. The use of internal conductive planes and separating dielectric layers is described in detail above and further description is not believed necessary. The cross-sectional configuration depicted in FIG. 14 is representative of one embodiment of such a cross-section and may differ from that described in the foregoing illustrations, while still usable in the present invention.

Package 111 differs significantly from those described above, however, through the unique positioning of a pair of semiconductor chips in a stacked orientation on the upper surface of carrier 300. In one example, a first, lower chip 77' (preferably an ASIC chip) is electrically coupled to respective conductors on an upper surface of the carrier using a plurality of solder balls 79. Additionally, a second chip 77" (preferably a memory chip) is secured to the upper surface of chip 77', preferably using either a suitable adhesive known in the industry or, in the example illustrated in FIG. 15, such an adhesive in combination with a plurality of smaller solder balls 79'. An appropriate encapsulant is shown substantially surrounding the solder balls 79 and 79' as is known in the art.

Package 111 may also include additional, spaced semiconductor chips 77' also electrically coupled to the carrier's upper surface (as shown) for providing additional operational capabilities for the instant invention. Each additional chip 77' is also preferably an ASIC chip but the invention is not limited thereto as a memory chip (e.g., DRAM or SRAM) may be used.

Second chip 77", secured to lower chip 77', is electrically coupled to outer conductors on the carrier's upper surface using a plurality of wirebond connections 113. Wirebond connections for coupling semiconductor chips are known and further description is not believed necessary. Of significance, however, is that the upper, second chip 77" is wirebonded while in place atop the lower chip 77'. Thus, the lower chip is first electrically coupled using solder balls 79 to securely position it in place and form a second electrical connection with the desired electrical contacts on the carrier's upper surface. Thereafter, second chip 77" is then adhesively bonded and, uniquely, wirebonded such that the second chip's contact sites 115 are coupled to the respective contacts using connections 113. Finally, a quantity of encapsulant 14' (shown in phantom) is then positioned over the stacked chip arrangement and serves to protect the arrangement in the manner described above for encapsulant 14 (FIG. 2).

Although only one large solder ball 99 is shown for connecting package 111 to PCB 10, it is understood that each of the solder balls 99 are similarly coupled to PCB 10.

Thus, one or both of the semiconductor chips in the stacked arrangement may be coupled indirectly to PCB 10 in addition to also being coupled to one another, if desired. Still further, the stacked chip arrangement may be coupled to one or more of the adjacent chips 77'. The result is an electronic package having significant operating capabilities to uniquely couple several semiconductor chips to a common PCB. Although only four chips are depicted in FIG. 14, it is within the scope of the invention to utilize more than one pair of stacked chips on carrier 300 as well as more singular, separate chips 77', depending on the operational requirements for package 111. The invention is thus not limited to the particular number or orientation depicted in FIG. 14. Such a capability is considered extremely important, especially considering that the carrier is not of ceramic dielectric material.

The partial view in FIG. 15, as mentioned, illustrates an alternative positioning of the stacked chips on carrier 300 to thus represent a slightly different package 111'. The difference,

as mentioned, involves the utilization of smaller solder balls 79' to serve as thermal connections between both chips and also space chip 77' from chip 77" at a desired spacing.

Thus there has been shown and described a multi-chip electronic package which
5 comprises an organic, laminate chip carrier and a pair of semiconductor chips positioned on a first surface thereof in a stacked orientation. There has also been shown and described an electronic package assembly which includes the aforementioned carrier and semiconductor chips in combination with a circuitized substrate (e.g., PCB) in which a plurality of electrically
10 conductive elements (e.g., solder balls) are used to connect the chip carrier to the substrate. Significantly, the organic, laminate chip carrier of the invention is capable of having two or more semiconductor chips electrically coupled thereto which may be coupled together and/or coupled to electrical conductors on the undersurface (opposite side) of the carrier. Of further significance, these chips may be coupled in a high-speed manner so as to assure higher frequency signal
15 passage therebetween, thus resulting in a final product structure possessing greater capabilities than heretofore known in the art. The invention is able to attain these capabilities using a carrier comprised substantially of organic laminate material such as described herein which, as defined herein, will not deform or otherwise be harmed as a result of the relatively high temperature operation of the semiconductor chips during package operation and positioning on the desired underlying circuitized substrate. The chip carrier may in turn thus be comprised of at least two
20 portions formed in accordance with the teachings herein. Additionally, the carrier may include an internal capacitor structure such as defined and/or a thermally conductive member as part thereof designed to specifically prevent separation (disconnection) between the respective solder balls which form the connections between at least one of the chips and carrier and those, if utilized, between the undersurface of the carrier and the corresponding substrate. The invention
25 as defined herein thus possesses many significant advantages over known chip carriers of the multi-chip variety, while utilizing a substantially organic laminate body as a main portion thereof. The method defined herein for assembling this structure can also be conducted using many known PCB procedures and thus at a relatively lower cost than other processes used to form carriers of this type, particularly those made primarily of ceramic material.

30

While there have been shown and described what are at present the preferred embodiments of the invention, it will be obvious to those skilled in the art that various changes and modifications may be made therein without departing from the scope of the invention as defined by the appended claims.

CLAIMS

What is claimed is:

5 1. A multi-chip electronic package comprising:

an organic, laminate chip carrier including a plurality of electrically conductive planes spacedly positioned therein and separated by respective layers of dielectric material, said chip carrier including a plurality of electrical contacts on a first surface thereof and a
10 plurality of electrical conductors on a second surface thereof, selected ones of said electrical contacts being electrically coupled to selected ones of said electrical conductors; and

first and second semiconductor chips positioned on said first surface of said organic, laminate chip carrier in a stacked orientation, each semiconductor chip electrically
15 coupled to selected ones of said electrical contacts.

2. The package of claim 1 wherein selected ones of said electrical contacts are electrically coupled to other selected ones of said electrical contacts such that selected ones of said
20 semiconductor chips are electrically coupled to one another.

3. The package of claim 1 wherein said first semiconductor chip is directly positioned on said first surface of said organic, laminate chip carrier and said second semiconductor chip is positioned on said first semiconductor chip.
25

4. The package of claim 3 wherein said first semiconductor chip is an ASIC semiconductor chip and said second semiconductor chip is a memory chip.

5. The package of claim 4 wherein said first semiconductor chip is electrically coupled to
30 selected ones of said electrical contacts by a plurality of solder balls.

6. The package of claim 4 wherein said second semiconductor chip is electrically coupled to selected ones of said electrical contacts by a plurality of wirebond connections.
- 5 7. The package of claim 6 further including a heat-sinking member positioned substantially over said first and second semiconductor chips.
8. The package of claim 7 further including a stiffener member positioned on said first surface of said organic, laminate chip carrier and spacedly positioned about said first and second semiconductor chips, said heat sinking member being positioned on said stiffener member.
- 10
9. The package of claim 1 further including a quantity of encapsulant material located on said first surface of said organic, laminate chip carrier and substantially covering both said first and second semiconductor chips.
- 15
10. The package of claim 1 wherein said organic, laminate chip carrier includes a thermally conductive member therein and a plurality of solder elements electrically coupling said first semiconductor chip to selected ones of said electrical contacts on said first surface of said organic, laminate chip carrier, said thermally conductive layer having a selected thickness and coefficient of thermal expansion to substantially prevent failure of said electrical couplings formed by said solder elements on said selected ones of said electrical contacts.
- 20
- 25 11. The package of claim 10 wherein said thermally conductive member is comprised of a first layer of copper, a second layer of an iron alloy and a third layer of copper.

12. The package of claim 1 wherein said organic, laminate chip carrier includes a first multilayered portion including at least one dielectric layer and at least one conductive plane wherein said conductive plane includes signal lines capable of having signals pass therealong at a first frequency and a second multilayered portion bonded to said first multilayered portion and adapted for having said first and second semiconductor chips coupled thereto, said second multilayered portion including at least one dielectric layer and at least one conductive signal plane wherein said conductive signal plane of said second multilayered portion includes signal lines capable of having signals pass therealong at a higher frequency than said first frequency to thereby provide a high speed connection between said plurality of semiconductor devices.
13. The package of claim 12 wherein said second multilayered portion includes a conducting plane, first and second dielectric layers on opposite sides of said conducting plane, and the number of conductive signal planes is two, each conductive signal plane including said signal lines capable of having signals pass therealong and being positioned on a respective one of said first and second dielectric layers opposite said conducting plane.
14. The package of claim 13 wherein said second multilayered portion further includes a conductive through hole interconnecting at least one of said signal lines of said conductive signal plane on said first dielectric layer with at least one of said signal lines of said conductive signal plane on said second dielectric layer.
15. The package of claim 1 wherein said organic, laminate chip carrier includes an internal capacitor therein.
16. A multi-chip electronic package assembly including:

a circuitized substrate including a plurality of electrically conductive members thereon;

an organic, laminate chip carrier including a plurality of electrically conductive planes spacedly positioned therein and separated by respective layers of dielectric material, said chip carrier including a plurality of electrical contacts on a first surface thereof and a plurality of electrical conductors on a second surface thereof, selected ones of said electrical contacts being electrically coupled to selected ones of said electrical conductors;

first and second semiconductor chips spacedly positioned on said first surface of said organic, laminate chip carrier in a stacked orientation and electrically coupled to selected ones of said electrical contacts; and

a plurality of electrically conductive elements electrically connecting said selected ones of said electrical conductors on said second surface of said organic, laminate chip carrier to respective ones of said electrically conductive members on said circuitized substrate.

17. The assembly of claim 16 wherein said circuitized substrate is a printed circuit board.

18. The assembly of claim 16 wherein said plurality of electrically conductive elements comprises a plurality of solder members.

19. The assembly of claim 16 further including a first plurality of solder members electrically coupling said first semiconductor chip to selected ones of said plurality of electrical contacts on said first surface of said laminate chip carrier.

20. The assembly of claim 19 further including a plurality of wirebond connections electrically coupling said second semiconductor chip to other selected ones of said plurality of electrical contacts on said first surface of said laminate chip carrier.

FIG. 1

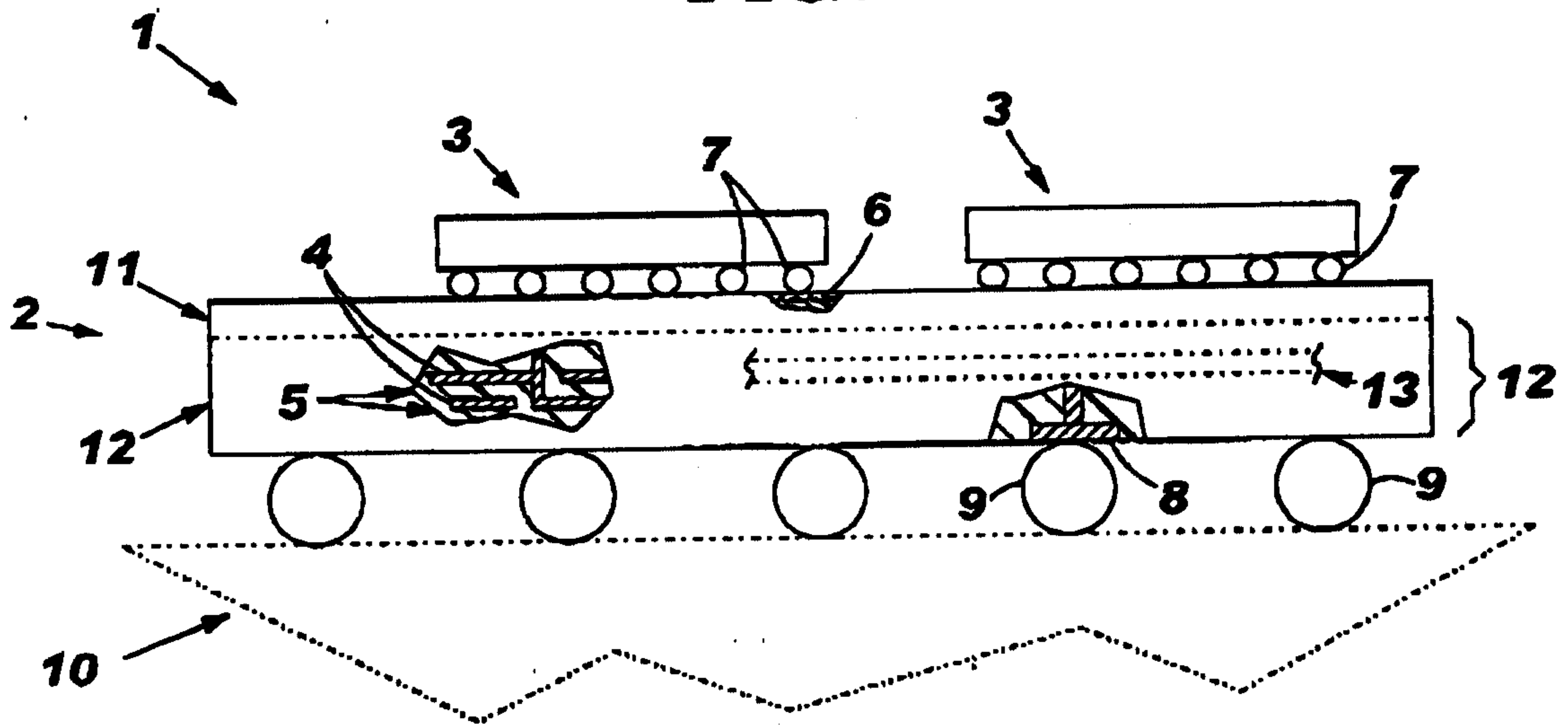

FIG. 2

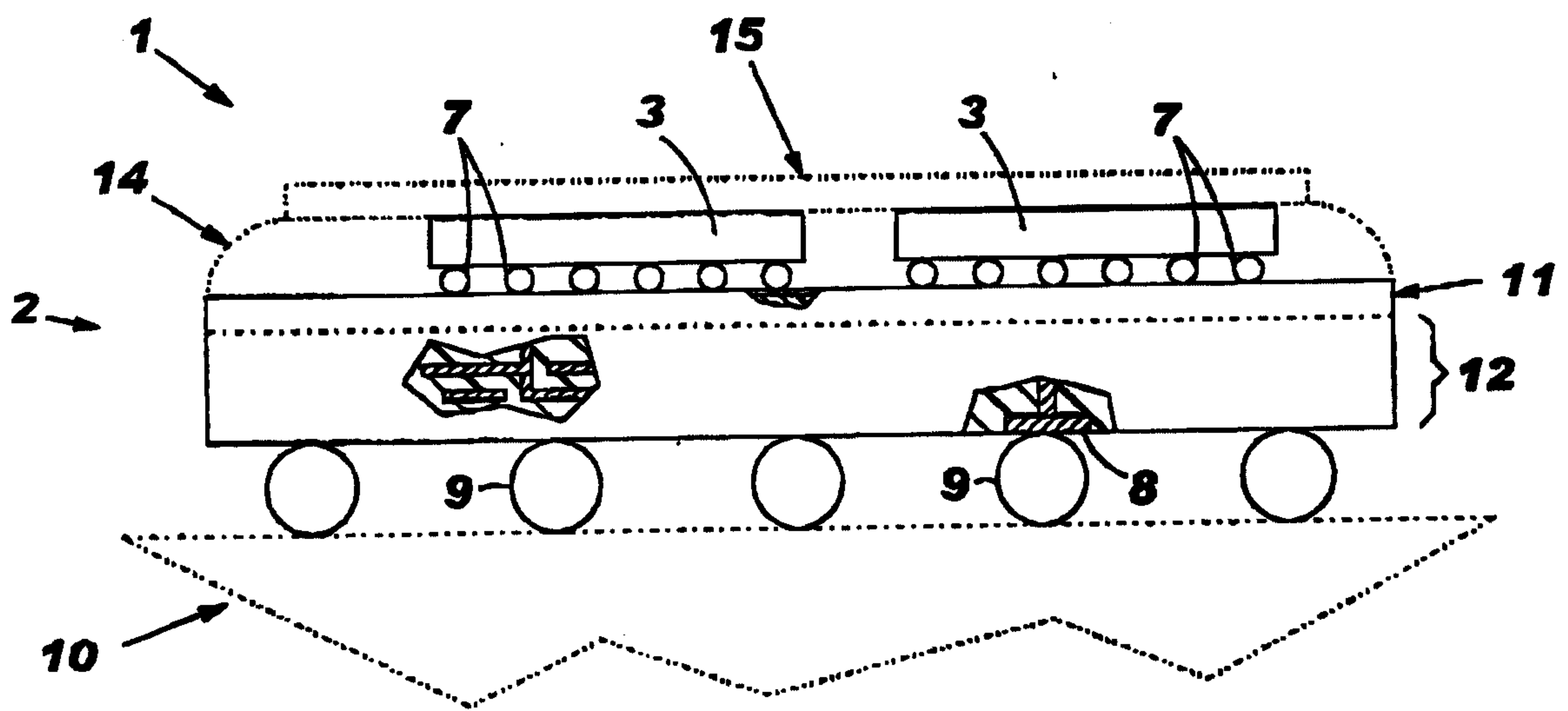

FIG. 3

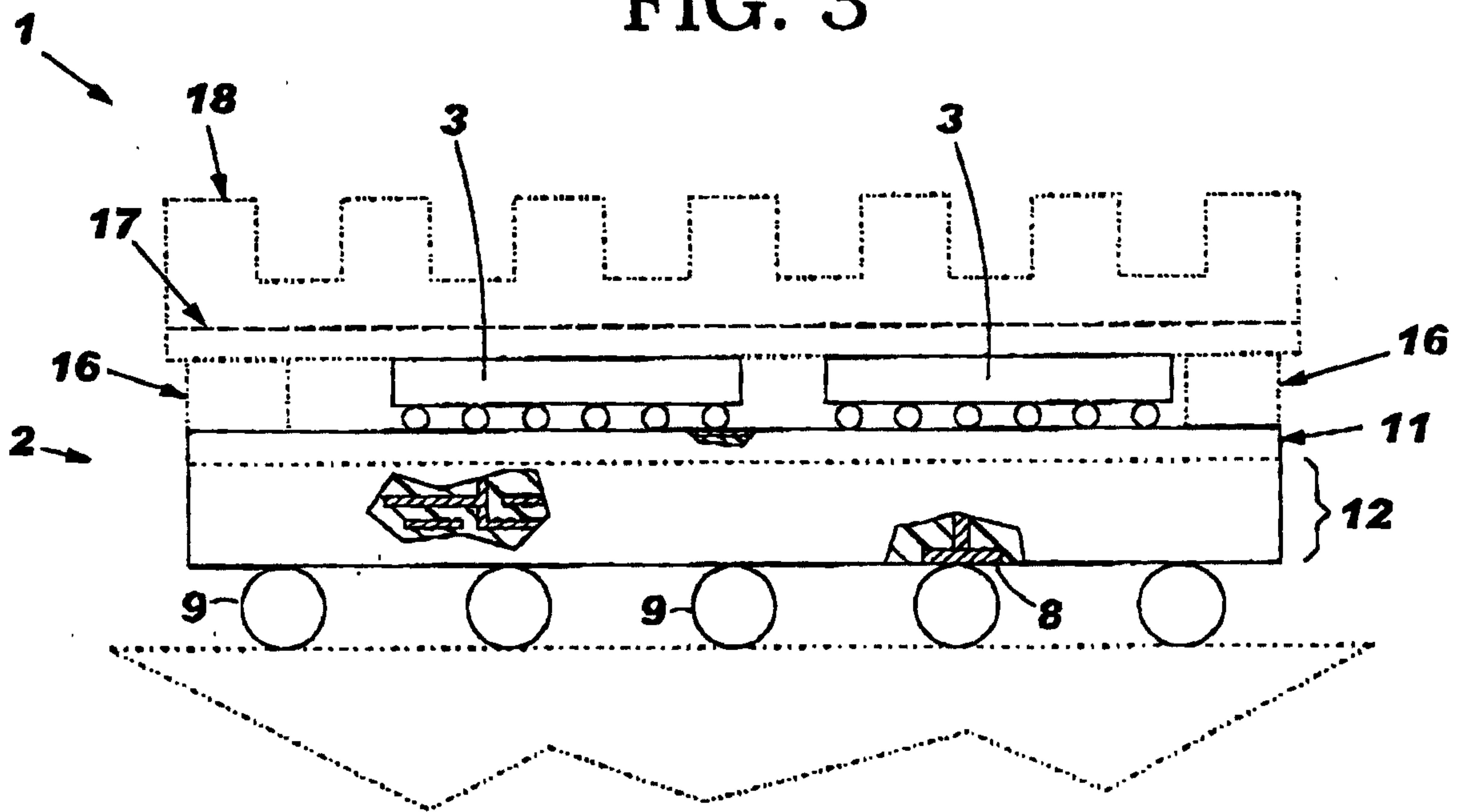

FIG. 4

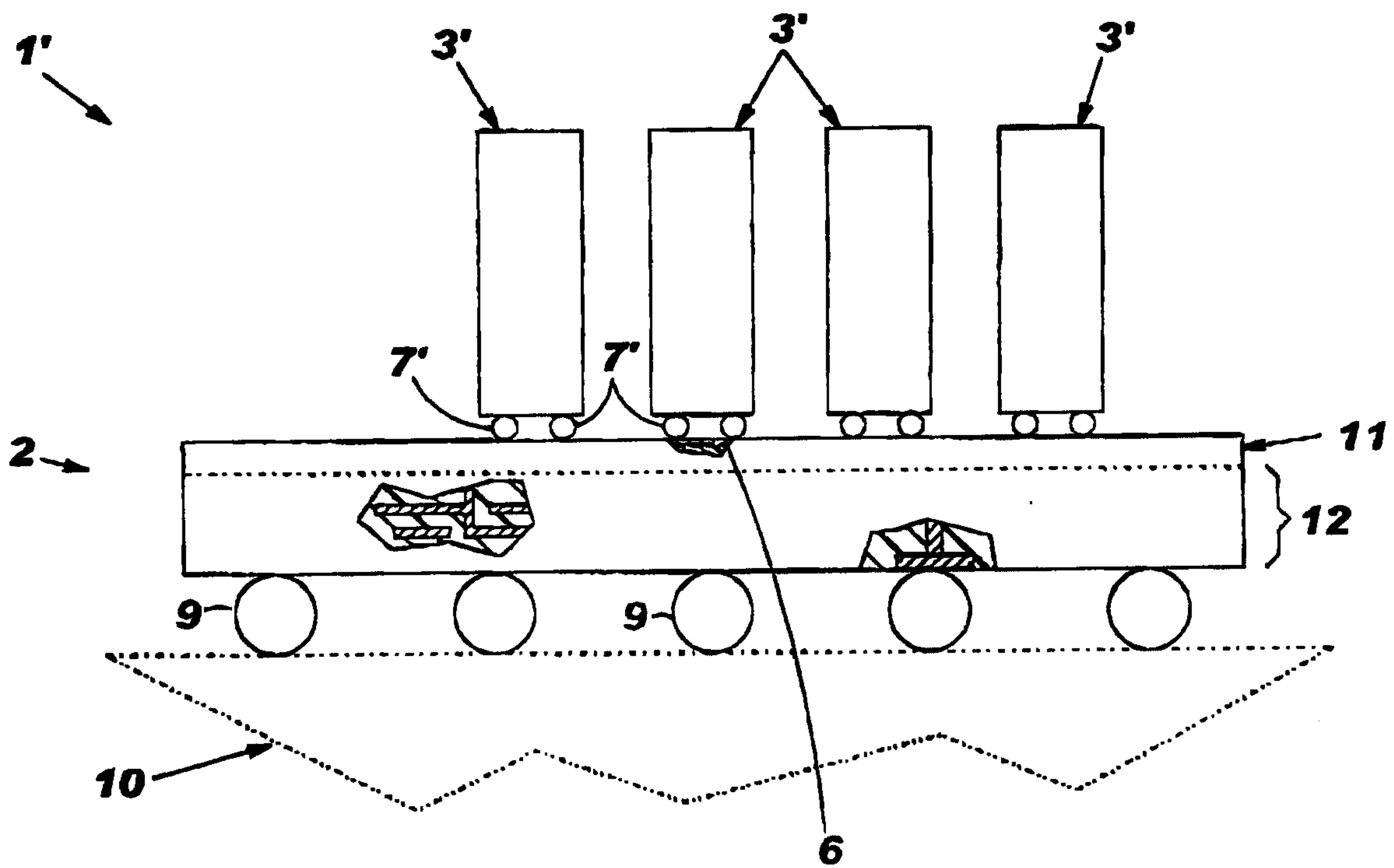

FIG. 5

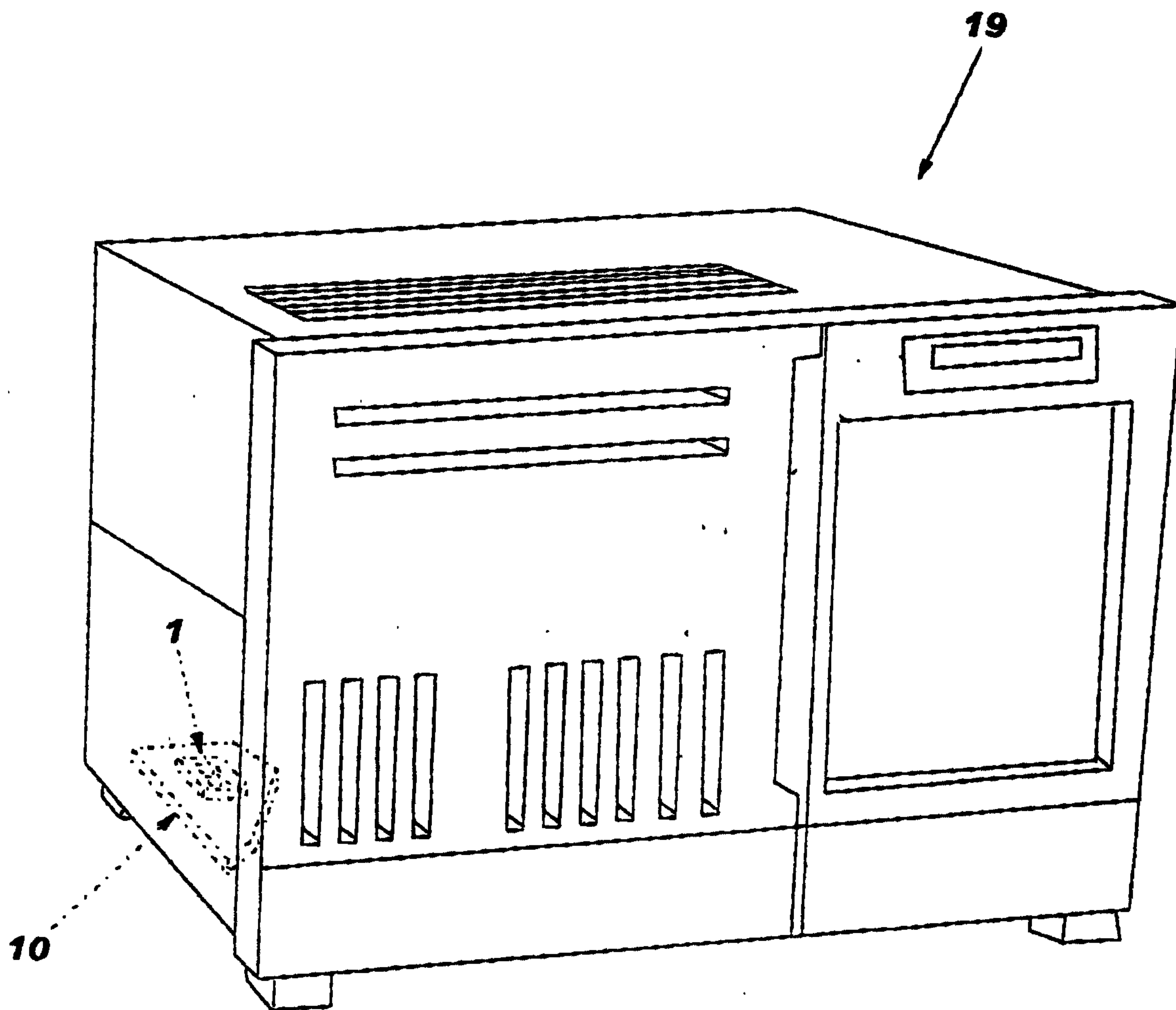

FIG. 6

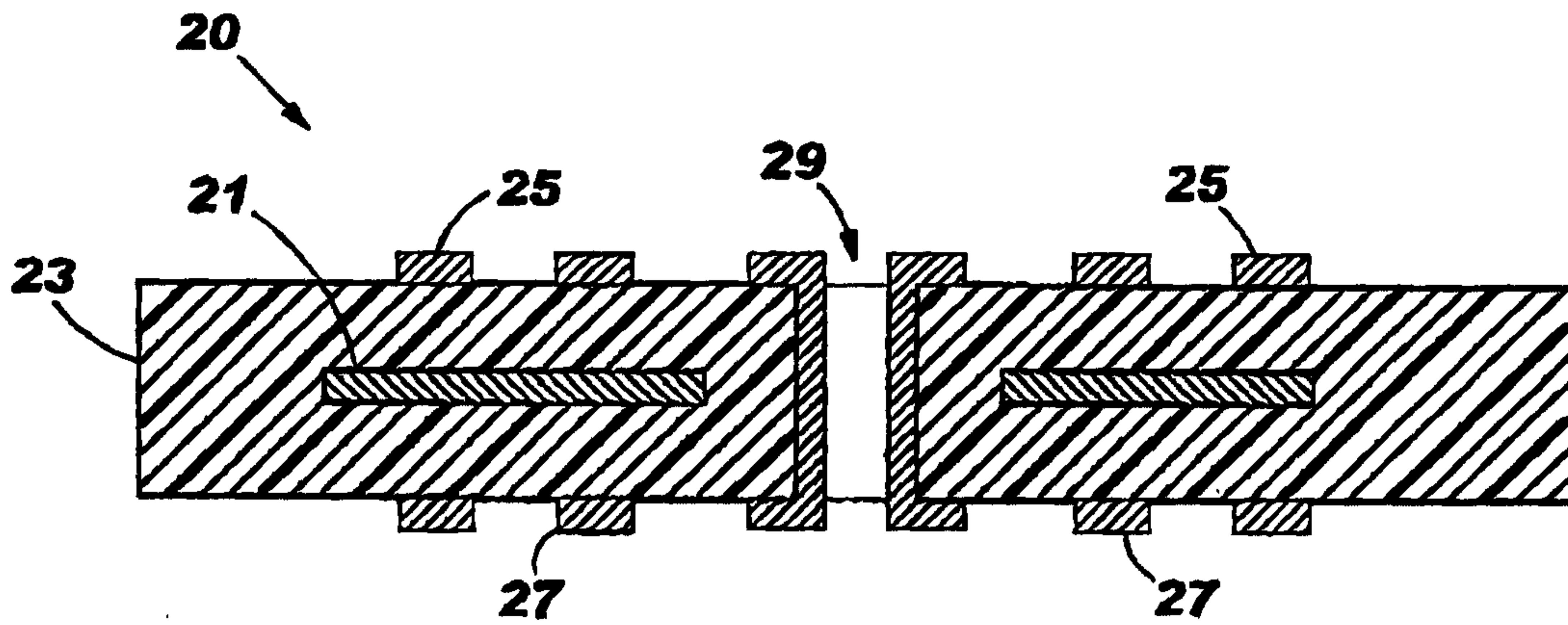

FIG. 7

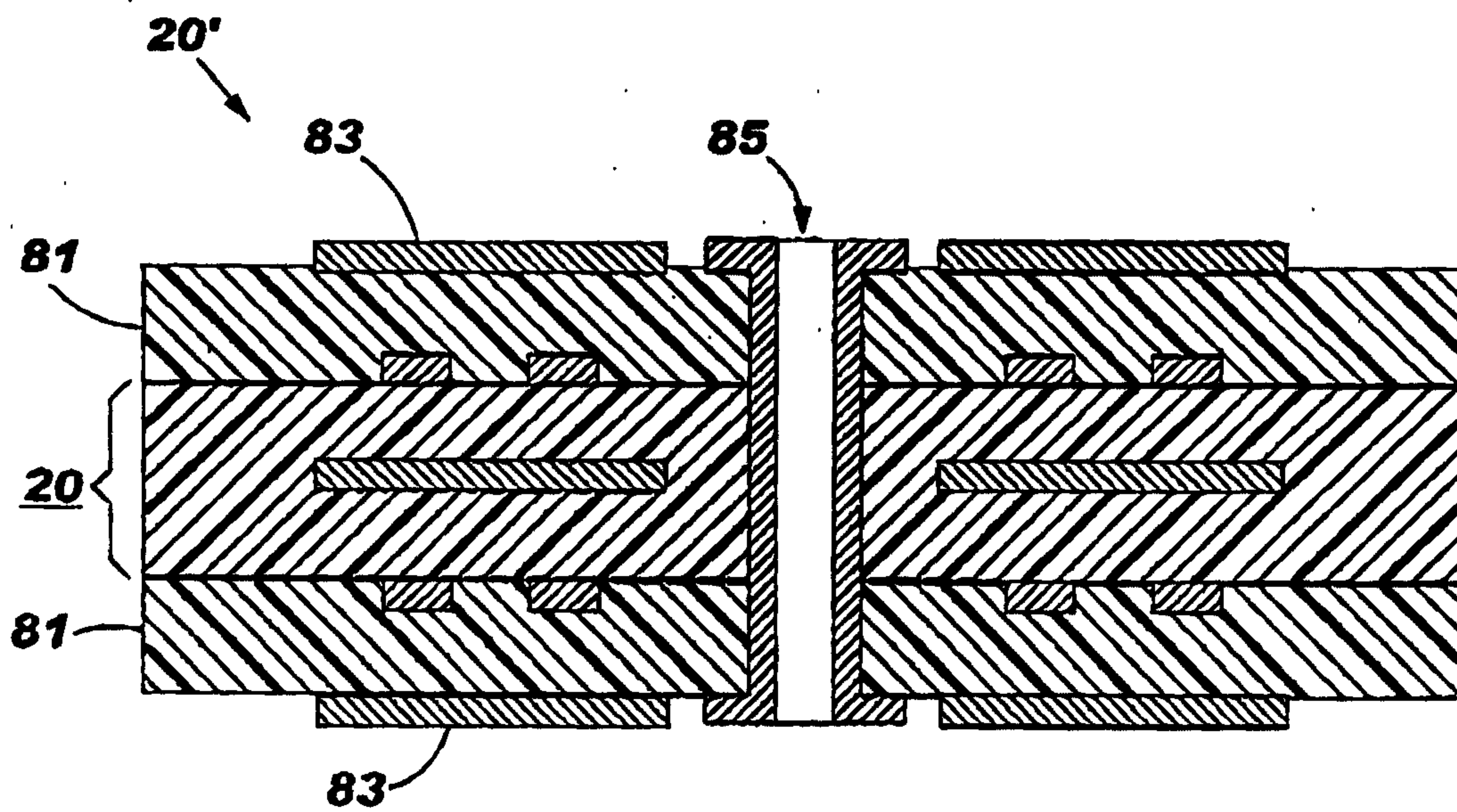

FIG. 8

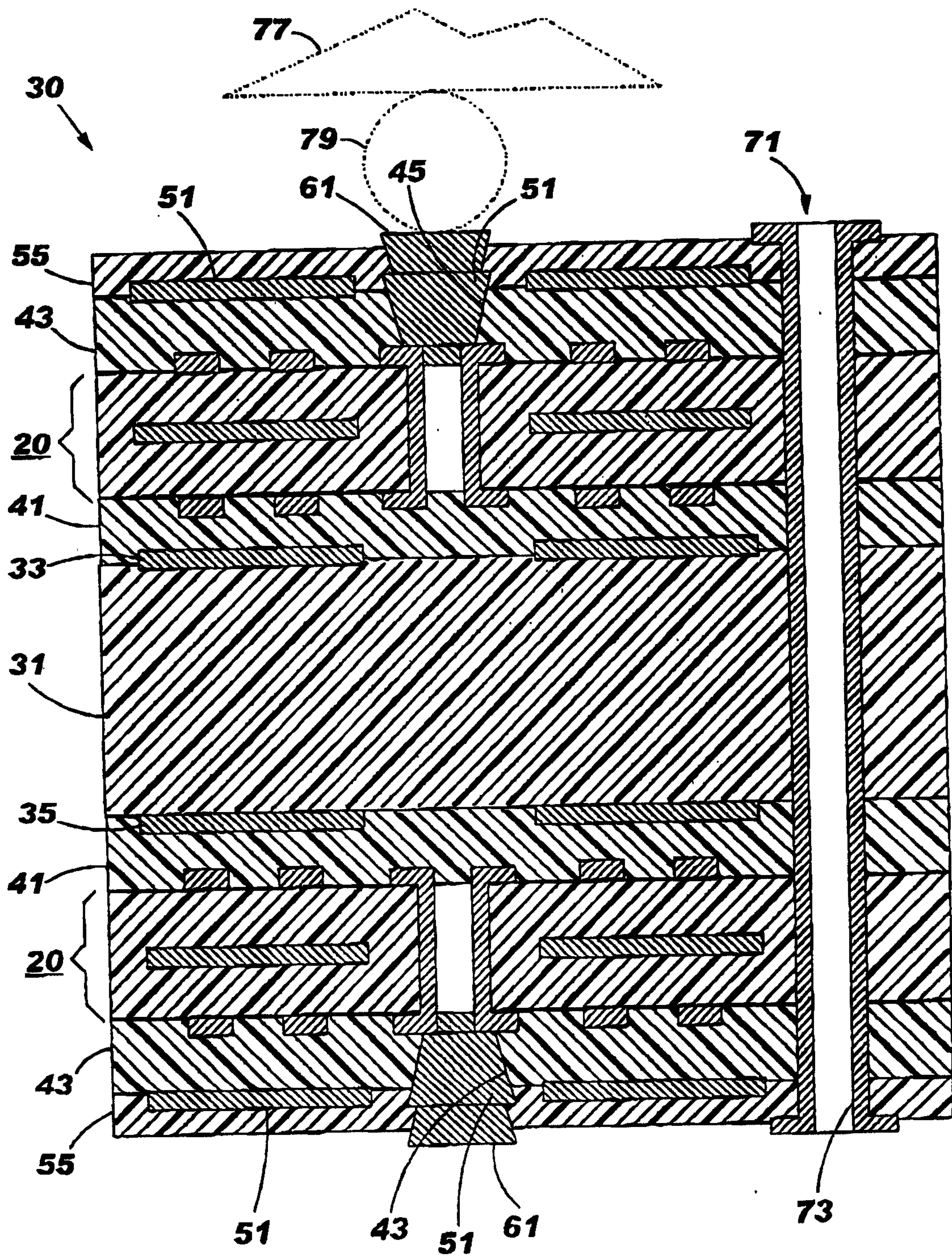

FIG. 9

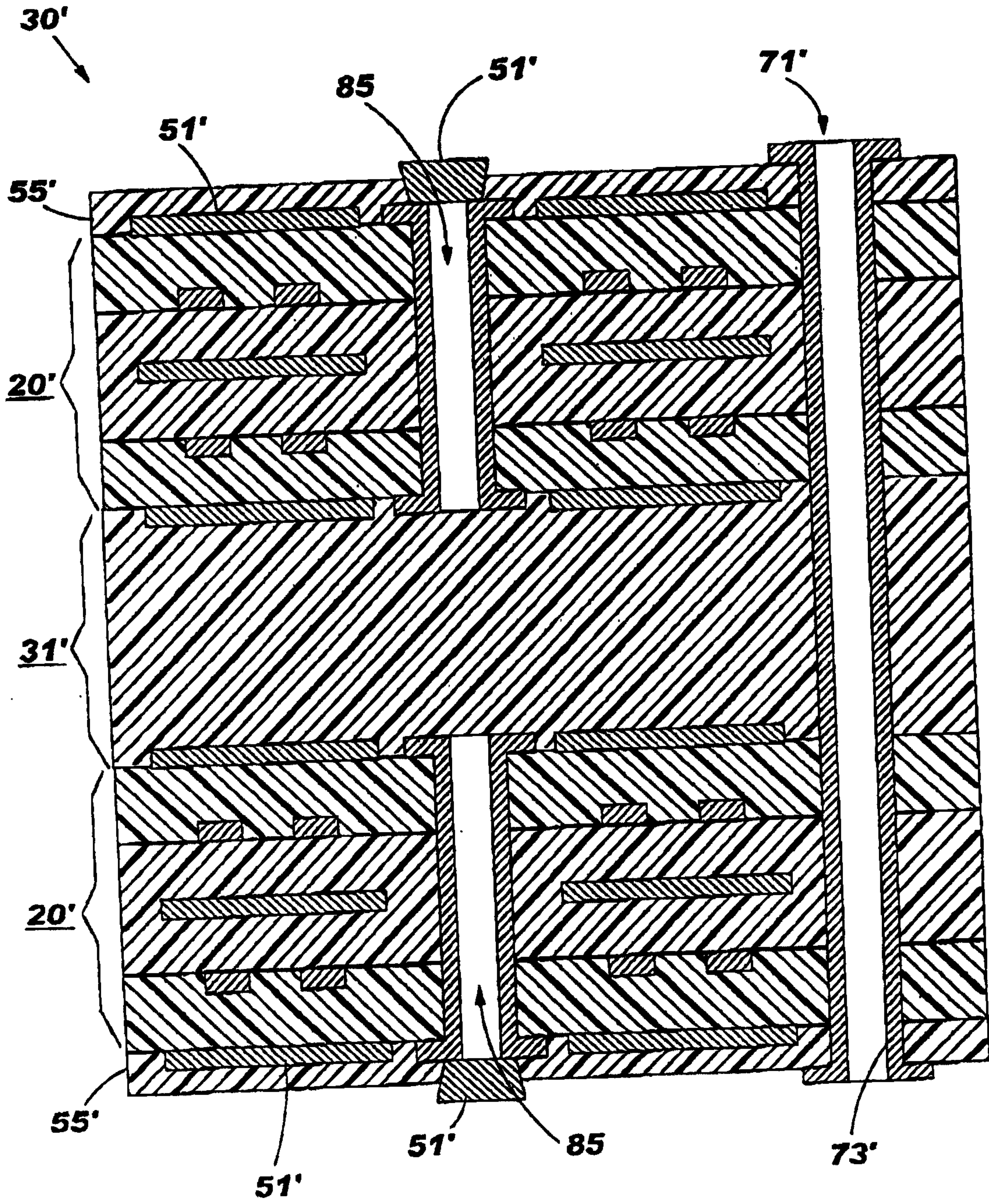

FIG. 10

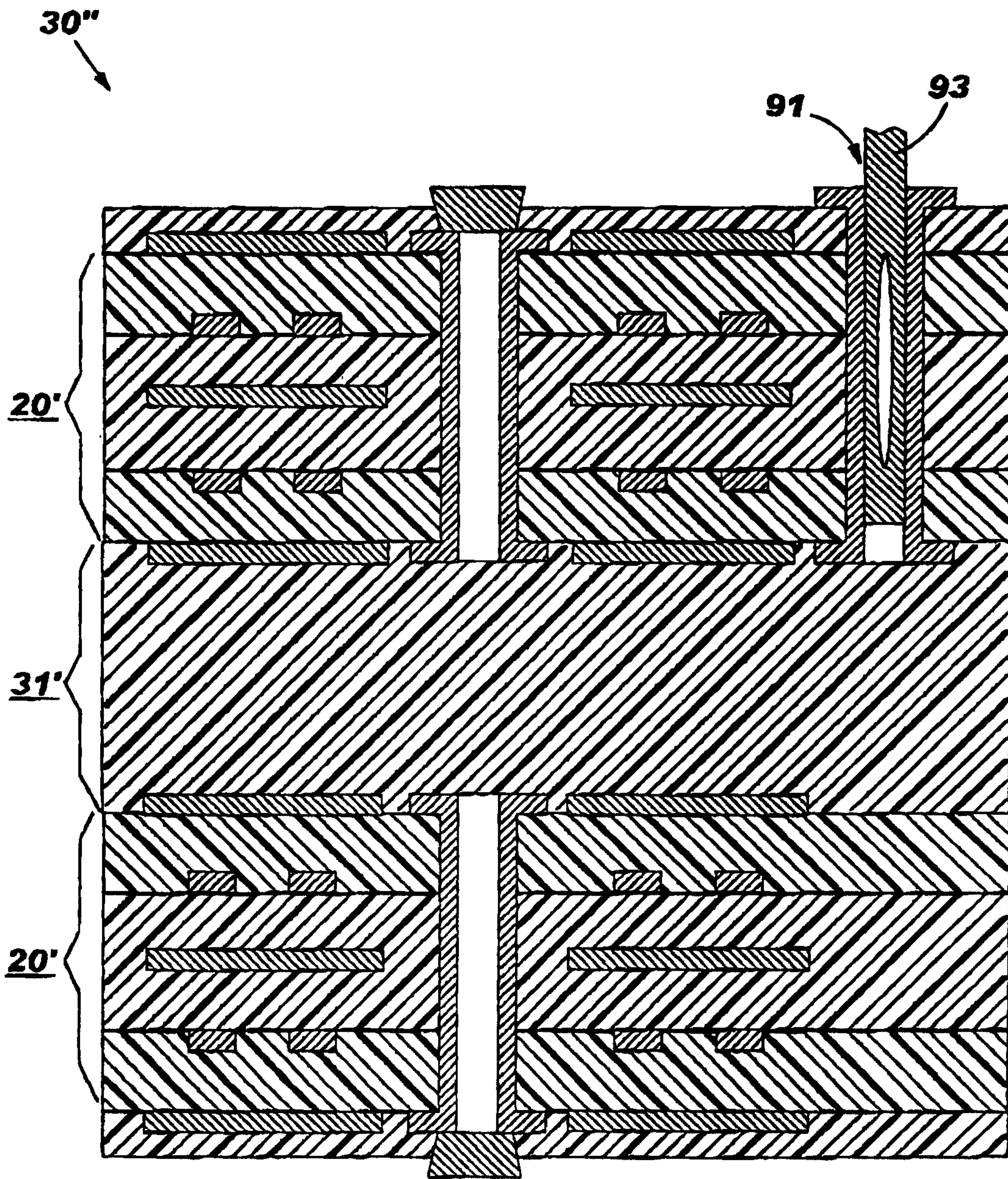

FIG. 11

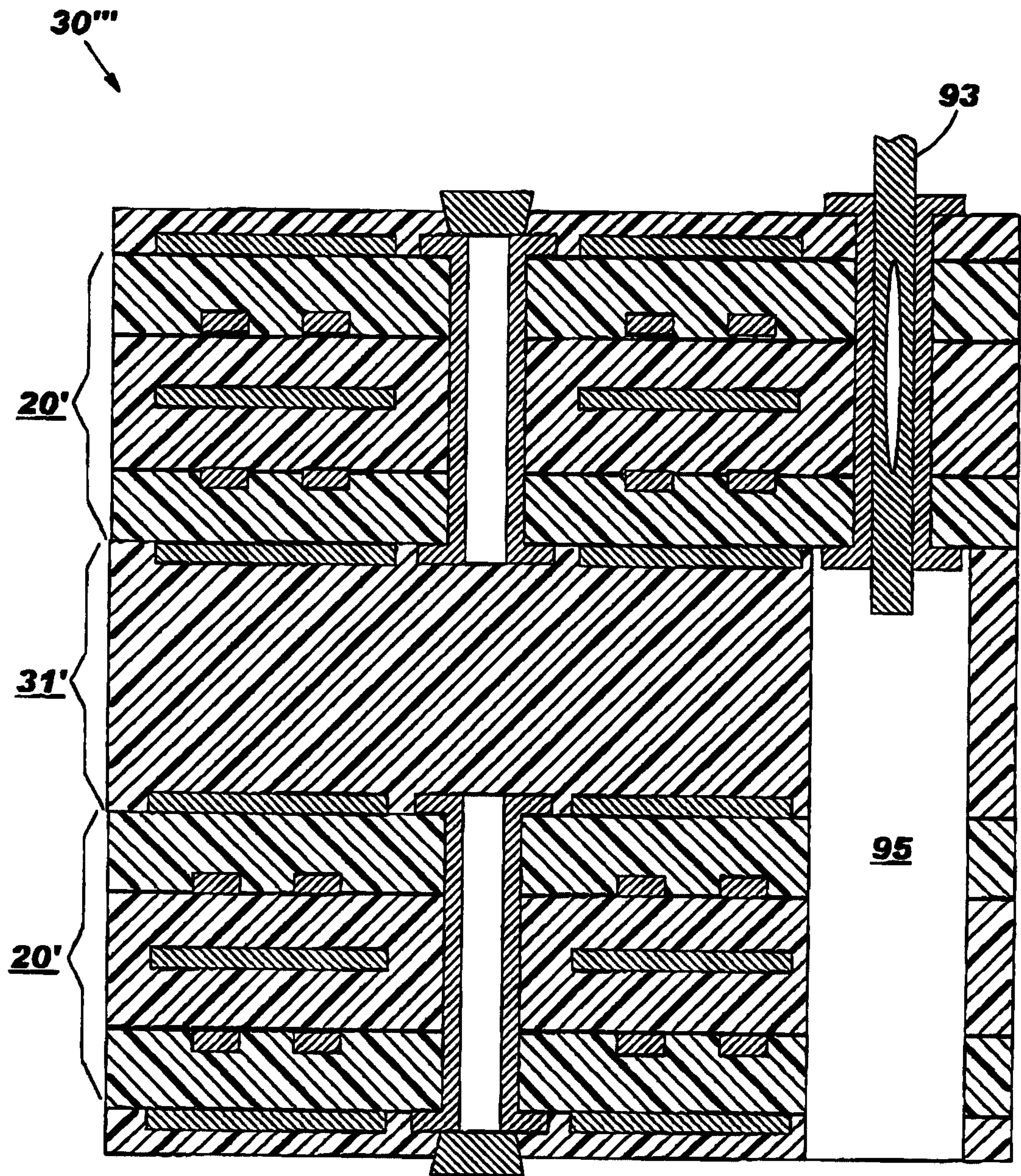

FIG. 12

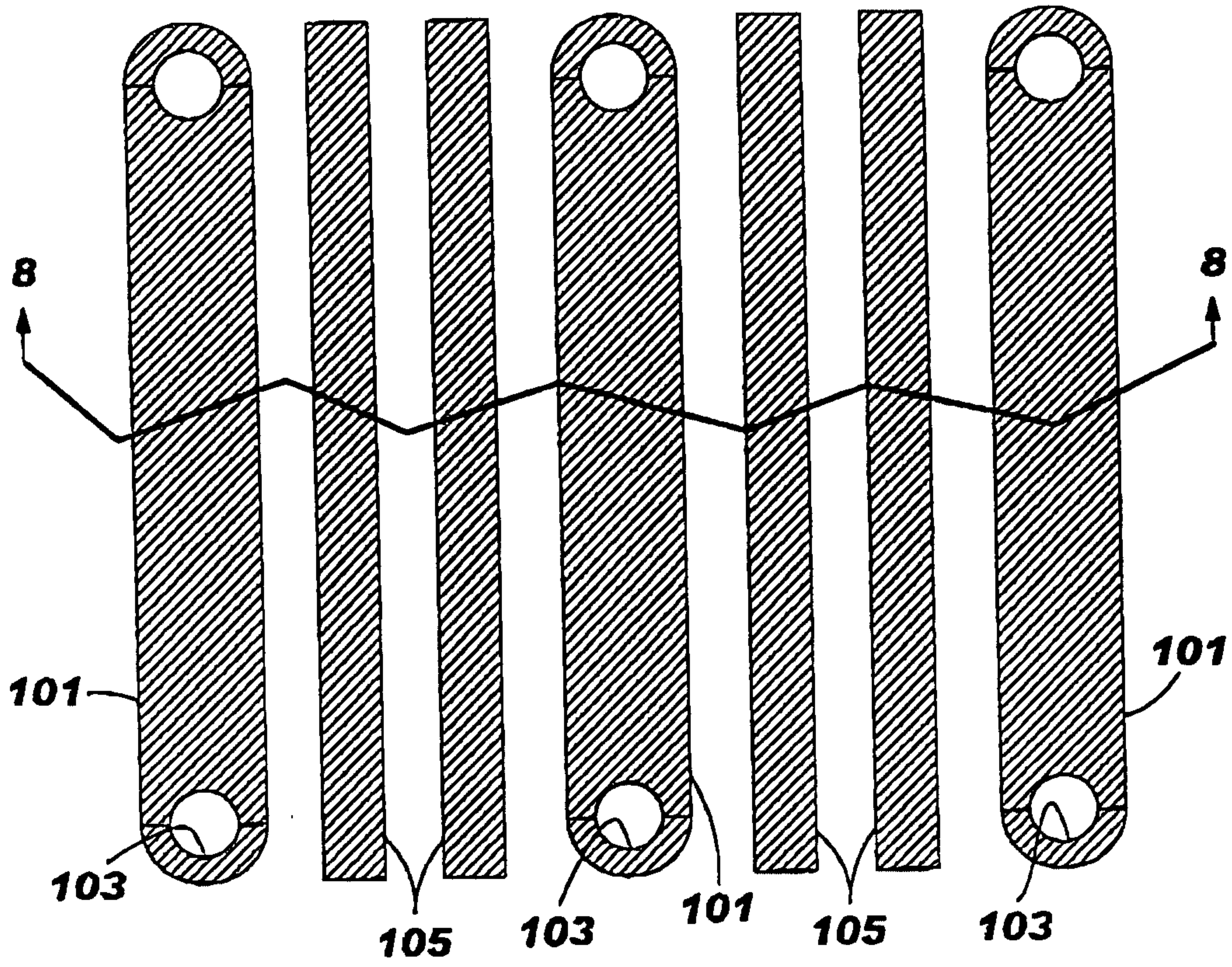

FIG. 13

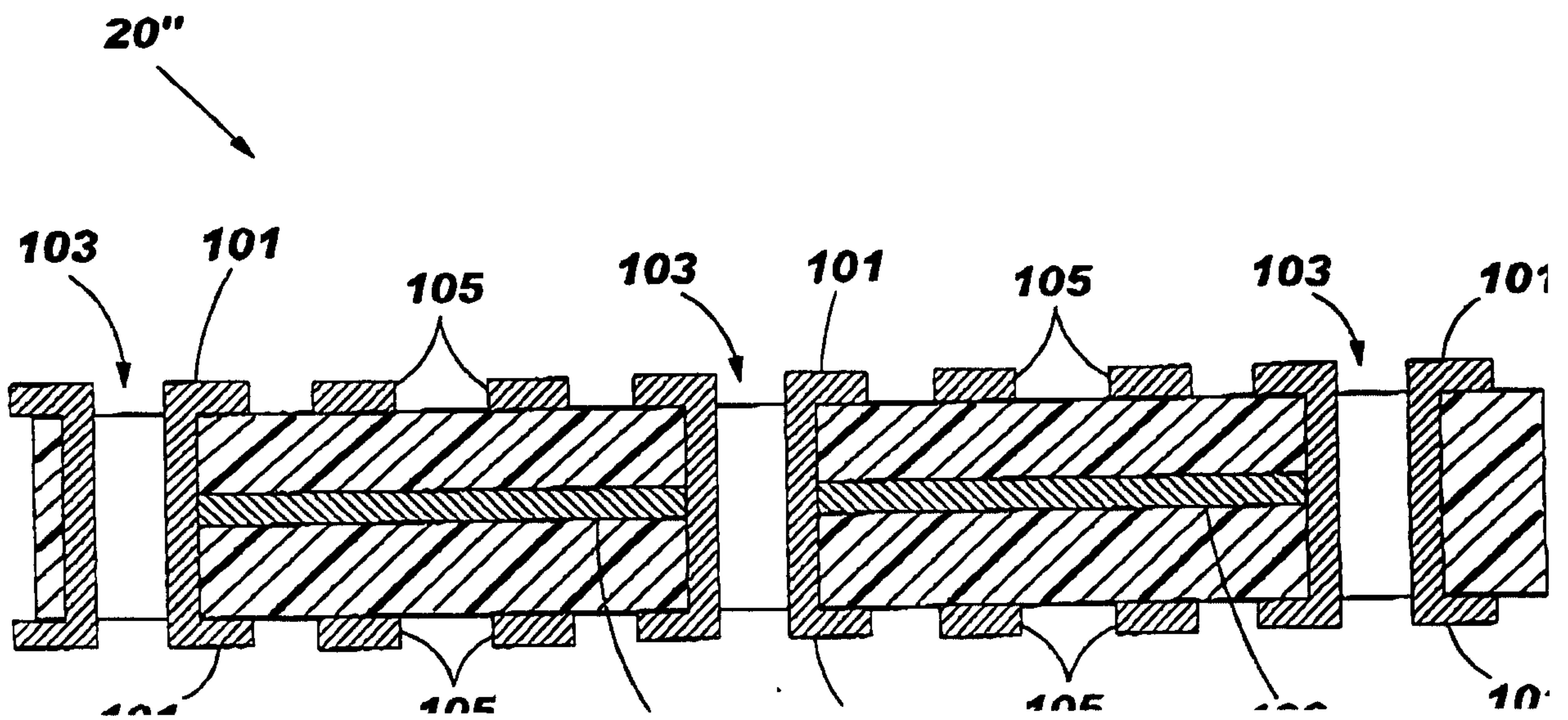

FIG. 14

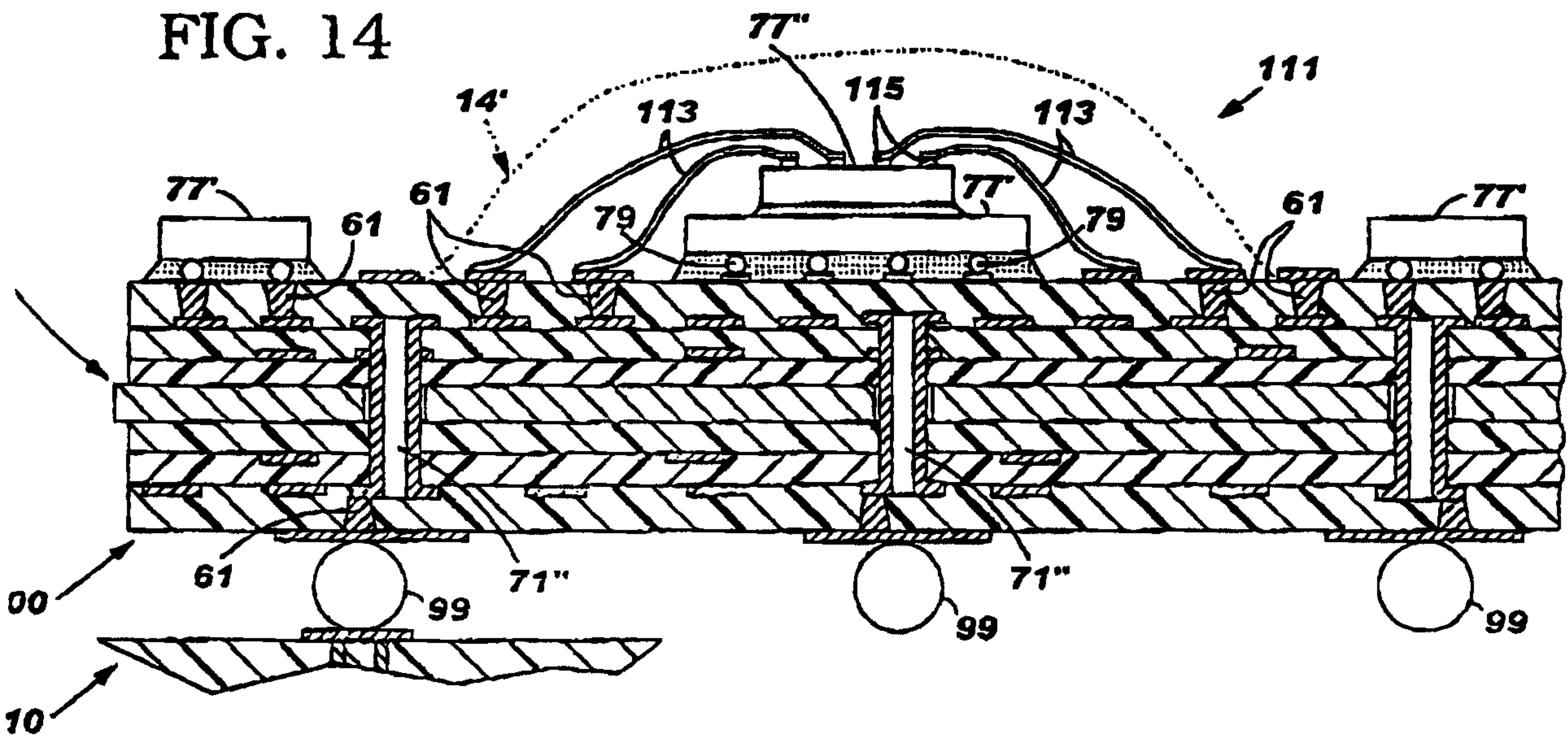

FIG. 15

