

April 26, 1938.

M. VON ARDENNE

CATHODE RAY TUBE

Filed May 24, 1934

2,115,093

Fig. 1

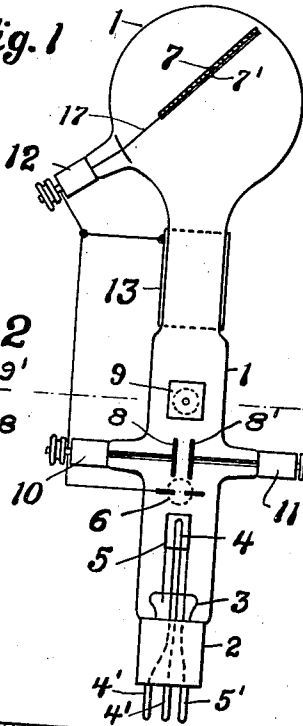

Fig. 2

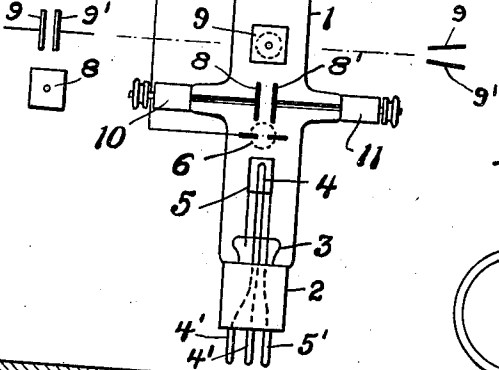

Fig. 3

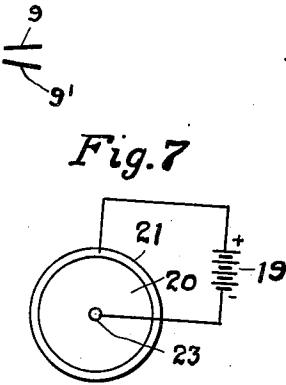

Fig. 6

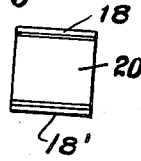

Fig. 5

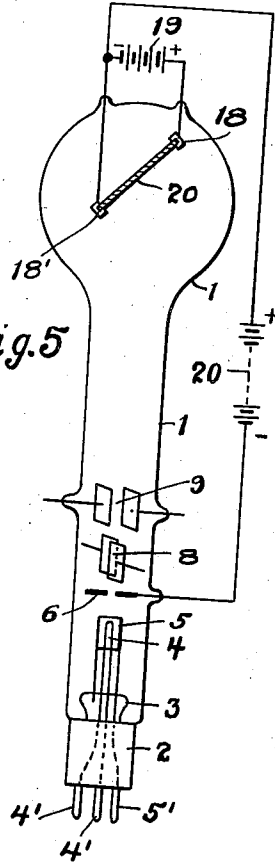
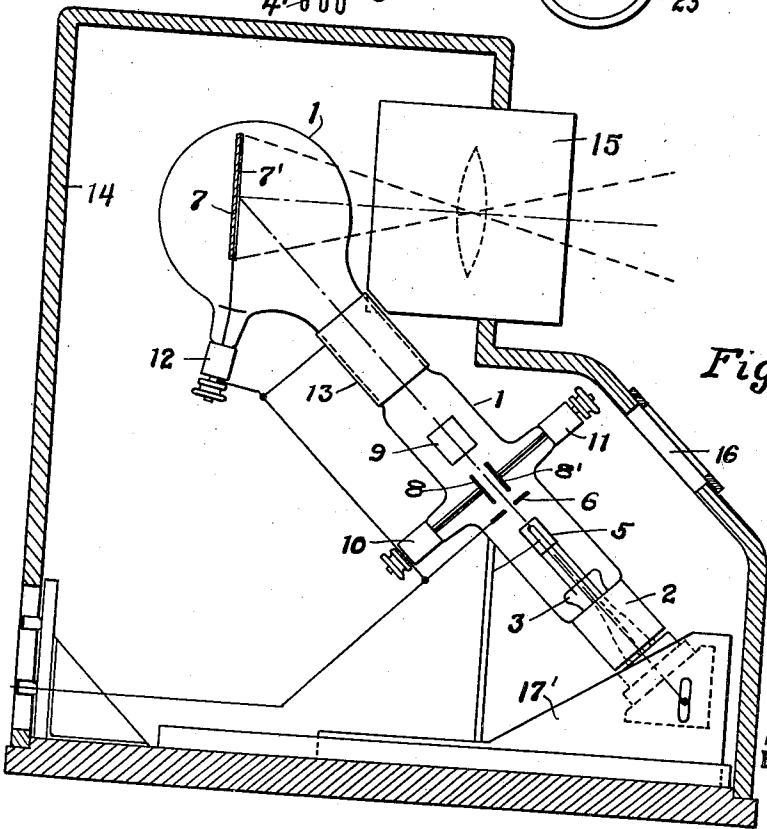

Fig. 4



INVENTOR
Manfred Von Ardenne

BY

Manfred Von Ardenne
ATTORNEY

UNITED STATES PATENT OFFICE

2,115,093

CATHODE RAY TUBE

Manfred von Ardenne, Berlin, Germany, assignor,
by mesne assignments, to Radio Corporation
of America, a corporation of Delaware

Application May 24, 1934, Serial No. 727,207
In Germany June 10, 1933

13 Claims. (Cl. 250—27.5)

My invention relates to electron discharge devices and more particularly to cathode ray tubes as used for oscillographs and in television transmission systems or similar electronic devices using a concentrated electron beam.

The general form of cathode ray tube as known in the art and used for oscillographs and in the cathode ray television systems, contains essentially the three parts: a source for producing a thin stream or pencil of electrons traveling at very high velocity, a fluorescent "target" or luminous screen for the electrons to strike against to produce a luminescent spot, and some mechanism for deflecting the path of the electron pencil in any direction and for varying the intensity of the electron beam to produce any desired pattern or image upon the fluorescent screen.

While my invention is in particular useful for cathode ray tubes including a gaseous atmosphere for focusing the electron beam, it is understood that the novel features of the invention as will be set forth are equally applicable to tubes operating with a partial or a high vacuum.

Cathode ray tubes of known type utilizing a gas for focusing the electron beam are characterized by their very great simplicity of both construction and operation.

One of the major disadvantages of cathode ray tubes of this type is the fact that the brightness of the luminous spot on the fluorescent screen is insufficient for many uses, such as for direct projection of a television image on a screen similar as in a moving picture or lantern projector.

It has not been possible to increase the anode voltage beyond several thousand volts for increasing the brightness of the luminous spot on the screen due to undesired interference with the concentrating action of the gas as the anode voltage increases, and it has furthermore not been possible to materially increase the degree of luminescence by measures and improvements applied to the source of the cathode ray.

Accordingly, it is one of the main objects of my invention to provide means in connection with a cathode ray tube for substantially increasing the degree of brightness of the fluorescent spot on the luminous screen as compared with tubes of this type heretofore known in the art.

There are several reasons for the limited luminosity of the fluorescent spot in cathode ray tubes hitherto known in which a translucent fluorescent screen is applied to the inside wall of the tube whereby the viewing direction is against the outer or rear side of the screen.

One disadvantage of a screen of this type is the fact that the luminescent energy produced by the impact of the electrons is distributed over two sides of the screen; that is, the front side and the rear side, resulting in substantial reduction of the useful luminescence, as is obvious.

Accordingly, it is another object of my invention to provide a luminous screen for use in cathode ray tubes in which the luminous energy is applied to the front side of the screen only impinged upon by the electron beam for increasing the degree of luminescence obtained.

Another disadvantage of screens used in tubes heretofore known is due to the fact that the screen has to be very thin to produce sufficient luminosity at the rear side which in turn entails a reduction of the luminosity by absorption by the screen itself.

Accordingly, a further object of my invention consists in the provision of a fluorescent screen for use in cathode ray tubes in which the thickness of the screen is not limited, enabling the use of a screen of increased thickness as compared to hitherto known tubes for increasing the degree of fluorescence obtained.

Another disadvantage inherent in cathode ray tubes of known construction is the fact that a large amount of light passing the glass wall of the tube to which the screen is applied, is lost by total reflection from the outer wall of the tube with the added disadvantage of disturbing "halo" effects being produced which in turn greatly impair the "detail" or definition of the pattern or image recorded on the screen.

Accordingly it is another object of my invention to provide a fluorescent screen for use in cathode ray tubes in which losses by total reflection and a blurring of the picture by "halo" effects due to total reflection from the outer wall of the base to which the screen is applied is substantially eliminated.

Still a further disadvantage of luminous screens used in cathode ray tubes heretofore known is the fact that on account of the bad heat conductivity of the glass wall upon which the screen is applied, the particles of the screen impacted by the impinging electron pencil became excessively heated, resulting in impairment of the luminescence, causing in turn a decrease of brightness of the luminous spot and a blurring or loss of "detail" of the pattern or image produced.

Accordingly it is another object of my invention to provide a luminous screen for use in cathode ray tubes in which heat produced by the impact of the electron pencil upon the screen is

readily dissipated, resulting in considerable increase of the luminosity and definition of the pattern or image on the screen.

In cathode ray tubes such as used for recording rapid electrical or other phenomena, or for scanning and reconstructing an image in television systems, it is often desirable to provide an optical lens system for observation or recording of the pattern or image produced on the screen. In order to secure a sufficiently bright image, "high speed" lens systems of large focal length determined by the distance from the screen; that is, by the dimension and shape of the tube, are used. Such lenses are prohibitively expensive for common use.

Accordingly it is a further object of my invention to provide a novel tube construction for a cathode ray tube enabling the use of high speed objectives of short focal length, resulting in substantial decrease of initial cost.

Another disadvantage experienced in cathode ray tubes of hitherto known construction is the fact that due to irregularities in and at the surface of the glass wall of the tube, optical distortions of the image or pattern observed or recorded through the glass are produced.

It is a further object of my invention to provide a tube construction by which optical distortions due to defects or irregularities of the glass bulb are substantially eliminated.

When using a screen in a cathode ray tube which is arranged at an angle to the axis of the tube as in accordance with the preferred embodiment of my invention, a number of distortions and irregularities of the pattern or image are produced due to the inclination of the screen with respect to the tube axis.

Accordingly, a still further object of my invention consists in the provision of means for eliminating distortions of the pattern or image produced on the screen and caused by the inclination or arrangement of the screen at an angle other than at right angle to the tube axis as in previous constructions known in the prior art.

In many cases, especially in television, it is desirable to project the image by the use of a projecting lens. The smaller the image, the smaller and cheaper will be the objective required, as is obvious.

It is therefore a further object of my invention to provide means in a cathode ray tube for producing an image of limited size and increased brightness and definition adapted for direct reproduction or projection by means of a simple and inexpensive optical lens system.

Cathode ray tubes as described by my invention are especially adapted for use in television systems due to the attainment of a substantial increase of the brilliancy and definition of the image as compared to systems heretofore known. As is well known, the main factors determining the quality and brilliancy of a television image are the amount of light available in the scanning light spot on the one hand, and the speed with which the spot moves over the screen area to reconstruct the image at the receiver. The slower the scanning speed, the brighter will be the picture, as is obvious. The decrease of the scanning speed is limited on account of the requirement for desired definition or contrast of the image as well as by the size of the image. In this respect, the use of a cathode ray tube for receiving television images as described by my invention in which the optical efficiency or the efficiency of the conversion of the available electrical energy in the scan-

ning beam into light is increased to a maximum has resulted in a marked increase of the quality of the picture to an extent as to bring cathode ray tube television within the range of practical perfection.

The above and further objects and aspects of my invention will become more apparent as the following description proceeds taken with reference to the accompanying drawing in which I have illustrated one form of embodiment of a cathode ray tube in accordance with the invention. The drawing is to be regarded as illustrative only of the underlying principle and novel features of the invention which, as will become obvious, is subject to various modifications and variations coming under the broad scope thereof as expressed in the appended claims.

In the drawing, in which similar reference numerals identify similar parts throughout the different views;

Figure 1 illustrates a construction of a cathode ray tube embodying the novel features of my invention.

Figure 2 is a side view of the deflecting plates of the tube according to Figure 1.

Figure 3 is another side view of one pair of the deflecting plates constructed according to the invention.

Figure 4 shows a tube as illustrated by Figure 1 mounted in a container associated with an optical lens system for either direct observation or projection or recording of the image or pattern produced on the screen.

Figure 5 shows a tube similar to Figure 1 with an additional improvement according to the invention embodied therein, and;

Figures 6 and 7 are detailed views of a luminous screen structure provided in a tube according to Figure 5.

According to my invention I substantially avoid the light losses inherent in luminous screens of heretofore known design by the provision of a screen which is viewed from the front side instead of from the rear side, as known in previous constructions. According to a preferred embodiment, I provide a plate, preferably a metallic plate insuring a good heat conductivity, upon which the fluorescent material is applied in the form of a coating of desired thickness to insure maximum luminescence produced by the impinging electron pencil.

The heat conductivity of the plate carrying the luminescent screen may be further increased by blackening the outer surface and by the arranging of cooling means such as cooling ribs similar as has become known in X-ray tubes.

The optical efficiency of a screen of this type may still be further increased in accordance with another feature of my invention by providing the front of the screen plate or base carrying the luminescent material with a mirrored or otherwise highly light reflecting surface. I have found that the use of an aluminum plate with a polished surface upon which the luminescent material is applied gives very satisfactory results.

The use of such a screen entails a number of further problems to be solved to adapt the tube for practical use, especially for use in television systems or for direct projection of the picture or for photographic recording with a time axis secured by a constantly increasing deflecting voltage pulling the luminous spot across the screen at a constant velocity. In a construction as pointed out, it is not possible to view the screen at right

angles and furthermore the irregularities of the glass of the tube result in great optical distortions, as pointed out.

I overcome these disadvantages in accordance with a further feature of the invention by inclining the plane of the screen relative to the axis of the tube preferably at an angle of 45° with the axis of one of the two pairs of deflecting plates. In this manner, it is possible to view the screen at right angle to its surface or to reproduce or project the pattern or image by means of an optical system having its axis arranged at right angle to the screen surface. It is furthermore possible by such an arrangement to mount a "high speed" lens system of short focal length at a minimum distance from the screen enabling the use of inexpensive lenses of high power or relative aperture as the price of a lens of given "speed" or relative aperture decreases, the shorter the focal length, as is well known. For this purpose, I provide a spherical end portion of the tube in which the luminous screen is arranged which has the further advantage that the glass wall may be manufactured free from any defects or surface irregularities, resulting in an elimination of optical distortions.

Referring more particularly to Figure 1, I have shown a cathode ray tube construction according to the invention comprising a glass bulb consisting of a cylindrical neck portion housing the source producing the electron ray and the deflecting and controlling mechanism and a spherical end portion enclosing the luminous screen 7 arranged at an angle of 45° to the axis of the tube. The tube is mounted upon a base 2 and provided with a press 3 acting as a support for the cathode 4 and the well known cylindrical or concentration electrode 5. The cathode 4 may be either a directly heated cathode as shown, or it may be an indirectly heated cathode well known in the art. The cathode terminals are connected to prongs 4' and the concentration cylinder 5 is connected to a prong terminal 5' mounted at the bottom of the base 2 for connection to the proper operating potentials. I have furthermore shown at 6 an anode in the form of a disc with a central aperture for passing the electron pencil produced by the cathode 4 and the concentration cylinder 5. Numerals 8, 8' and 9, 9' represent the usual pairs of deflecting plates arranged at right angle to each other for both horizontal and vertical deflection of the cathode ray. I have furthermore shown at 10 and 11 terminals for applying the deflecting or sweep potential to the plates 8 and 8', respectively, and similar terminals may be provided for the plates 9 and 9' as is understood.

The luminous screen 7 consists of a base plate such as a metal plate upon which there is applied a coating of luminous material 7', such as of zinc silicate or the like well known in the art. I have furthermore shown the screen 7 connected to an outside terminal 12 through lead 17 for applying a potential to a screen equal to the anode potential, as shown, to prevent disturbing back current from the screen to the anode electrode. I have furthermore shown a constricted portion of the tube close to the spherical end portion, enabling further the close mounting of an inexpensive optical lens system of short focal length, as will be seen more clearly from Figure 4. The diameter of the constricted portion is limited by the dimension of the screen 7 and should be such as to allow a maximum sweeping angle of the electron pencil to cover the entire surface of the

screen 7. In order to prevent the effect of disturbing wall charges, I have shown a further electrode 13 applied to the outside wall of the constricted portion maintained at anode potential by the connection, as shown.

The inclined mounting of the screen involves various added distortions of the luminous spot or the pattern or image produced on the screen 7. These distortions increase as the length of the tube or of the electron ray, respectively, decreases, a procedure which I have found advantageous, as will be pointed out hereinafter.

In general, especially in the case of television, it is required that the sensitivity of deflection is substantially equal for both pairs of deflecting plates. By the provision of an inclined screen and assuming that the distance between the deflecting plates in both deflecting systems is the same, it is seen that the deflecting plate system arranged close to the anode electrode which is furthermore at a greater distance from the screen than the other plate system, has a considerably increased sensitivity of deflection. I compensate for this difference of sensitivity by making the sensitivity of the plates arranged close to the anode less than the sensitivity of the plates arranged close to the screen. This may be obtained, for instance, as shown by Figures 1 and 2, by varying the distance between the deflecting plates; that is, by using a larger distance between the plates 8 and 8' arranged close to the anode 6 as compared with the distance between the plates 9 and 9'.

A further distortion is produced by the deflection caused by plates 9 and 9' in a vertical direction due to the inclined position of the screen 7. This has the effect, as is seen, that the portions of the image or pattern at the part of the screen which is at closer distance to the deflecting system are concentrated while the portions of the image or pattern at larger distance from the deflecting system are expanded. Thus in the case of equal deflecting or sweep voltages applied to both pairs of deflecting plates, which under normal conditions would result in a luminous surface of substantially square shape, the distortion produced due to the inclination of the screen by the deflecting plates 9 and 9' will result in a surface of trapezoidal shape as compared to a square when no distortion would be present. I avoid this distortion in accordance with my invention by arranging plates 9 and 9' at an angle such as shown in Figure 3 in such a manner that within the range of shorter length of the cathode ray the sensitivity of deflection is increased on account of the greater electric field strength between the plates while for the range of longer length of the cathode ray the sensitivity of deflection is less, due to the decreased field on account of the larger distance between the plates 9 and 9'.

A further effect produced by the inclined position of the screen 7 results in a distortion of the shape of the luminous spot produced by the impinging electron pencil. Thus, it is seen that if the cross-section of the pencil under normal conditions is substantially circular producing a circular spot on the screen, in the case of an inclined screen as shown the circular spot will be distorted into an oval or ellipsoidal shape. I overcame this distortion in accordance with a further feature of the invention by providing a cathode producing a pencil of ellipsoidal cross-section, such as by making the emitting surface of the cathode of oval shape. The same effect may be obtained by using a loop-shaped filament which, as is

known, produces an oval electron stream. Thus, it is only possible to properly orientate the stream produced by the cathode so as to compensate the oval distortion to obtain a substantially circular spot on the inclined screen. For this purpose the large axis of the oval stream should be in a direction of the deflecting plate system mounted close to the fluorescent screen (9 and 9'), as is understood.

10 Still a further disadvantage caused by the inclination of the screen 7 in a tube as described is due to a decrease of definition of the luminous spot at certain portions on the screen; that is, at those parts on the screen which are at a farther distance from the cathode than the remaining parts. This results in a substantial lack of detail or definition especially in the case of television images at those portions of a pattern or picture lying at the outer portions of the screen; that is, for the larger deflecting angles.

15 I avoid the aforementioned defect and disadvantage of an inclined screen by the provision of means for applying different potentials to the various points on the luminous screen in such a manner as to substantially compensate for the varying length of the impinging electron pencil upon the individual elementary areas on the screen.

20 In accordance with one embodiment of the invention, I provide a screen consisting of resistance material such as shown at 17 in Figure 5, or alternatively I may use a base plate upon which a coating of resistance material is applied as by means of any well known method, such as by cathode sputtering or precipitation and the like. I have furthermore shown a battery 19 connected to metallic connecting elements or electrodes 18 and 18' mounted along the upper and lower edge of the screen 17 and in contact with the resistance surface 17 coated upon a base metal or itself forming the support for the luminous screen. This is shown in further detail by Figure 6. In this manner a gradual voltage increase from the upper to the lower edge on the screen is obtained which is added to a normal positive voltage 20 applied to the screen as shown in Figure 5. By properly choosing the voltage 19 it is seen that by an arrangement of this sort a gradually increasing potential is applied to the screen with increasing length of the impinging electron pencil, thus compensating and eliminating the difference in detail or definition of the luminous spot for different deflecting angles, as will be understood.

25 In the case of circular symmetrical patterns as obtained with spherical aberration, the arrangement as described may be circular symmetrical with the same symmetry center as the error on the image. The arrangement may be analogous to Figure 5 or Figure 6 by using a circular resistance screen 20 with a peripheral electrode 21 and central electrode 22 connected to the compensating battery 19 as shown in Figure 7.

30 It is understood that by an arrangement as described in Figures 5 to 7 for applying different potentials equally or otherwise distributed over the fluorescent screen; that is in other words, by adjusting the conductivity at different zones on the screen, any deviations or distorting effects other than those described due to any cause may be compensated in this manner, or alternatively any modification of the picture or pattern or its definition may be adjusted as desired. Thus for instance, it is possible to produce additional acceleration of the electron pencil between the

screen and a preceding accelerating electrode, especially for large deflecting angles in which case the screen itself may act as a means for final acceleration of the electron pencil to secure a desired luminosity or degree of definition, as may be desired, of the fluorescent spot produced by the electron impact.

35 In all the aforementioned cases where a resistance material is used in connection with the luminescent screen, care should be taken that the resistance of the support for the screen between the connecting electrodes is sufficiently low so as to prevent any substantial potential drop due to current flow caused by the impinging electron pencil and causing undesired modification and distortion of the electric field. I have found that in the case of tubes operating with comparatively low voltages, the voltage drop produced by the ray current along the support of the luminescent screen should be less than 10 volts. As with the usual tubes the intensity of the ray current is about 10^{-4} amperes, this value would correspond to a resistance of about 100,000 ohms which can easily be obtained by a sputtering or a precipitating method, as known in the art.

40 By using a tube as described hereinbefore with the additional means for compensating the various distortions and errors introduced by the inclination of the screen, I have been able to secure records of patterns or images on the fluorescent screen absolutely free from any distortion.

45 When an optical lens system is desired, such as for reproduction or projection of the screen pattern or image, the size and cost of the lens will be the less, the smaller the size of the fluorescent screen, as is obvious. However, a decrease of the dimensions of the fluorescent screen is only possible if the diameter of the luminous spot can be decreased at the same time. While in tubes as heretofore known in the art in which the luminous screen is directly applied to the inside wall of the tube, the diameter of the screen is from 12 to 20 centimeters, it has been possible by using a construction according to my invention to decrease the diameter of the luminous screen to 7.5 centimeters or less. Despite this small dimension of the fluorescent screen, I have been able to secure an exceedingly sharp definition or detail of the picture by decreasing the length of the ray or of the tube, respectively. I have found that with decreasing length of the ray, especially in the case of gas filled cathode ray tubes, the sharpness of the luminous spot increases considerably. As is known, the electron-optical representation of the cathode in the tubes as known in the art takes place with considerable enlargement depending, as pointed out, to a large extent upon the length of the ray. Investigations have furthermore shown that a decrease of the tube is advantageous not only on account of the decrease of the diameter of the luminous spot but also on account of the increase of the current at the top of the ray, resulting in a considerable increase of the luminescence produced by impact of the ray upon the luminous screen.

50 I have found by measurements that in the usual cathode ray tubes provided with a gaseous filling, the ray current at the top is only about 20% of the entire emission current, the rest being lost by stray electrons leaving the ray in a lateral direction. By decreasing the ray length, the loss by stray electrons is considerably decreased and the current intensity at the end or the recording place is increased by 50% 75

and more of the total emission current. This not only results in an increase of brightness to about the double value, but simultaneously is accompanied with a decrease of the interfering and disturbing side luminescence caused by the stray electrons to about half the value as compared to cathode ray tubes of standard design.

By means of cathode ray tubes constructed in this manner, images of exceedingly sharp contrast are obtained due also to the fact that the above-mentioned disturbing halo effects have been eliminated. It is furthermore advisable, as pointed out, to connect the metal screen with the anode to prevent a back flow of the electrons through the gaseous space in the tube, thus eliminating the number of disturbances caused by such back currents.

I have furthermore found it advisable, as pointed out, to prevent wall charges at the constricted portion of the tube by providing an outer metallic coating also connected to the anode or ground, respectively, as shown.

Referring more particularly to Figure 4, I have shown a cathode ray tube as illustrated by the previous figures, mounted in a housing 14 upon a displaceable support 17 for adjusting the tube relative to an optical system as indicated at 15, such as a projecting apparatus for direct projection of the screen image similar to a lantern slide or moving picture projector. The tube is mounted in an inclined position as shown and the objective system 15 arranged with its axis at right angle to the surface on the screen 7. I have furthermore shown at 16 an opening or window for controlling and observing the operation, especially the cathode heating of the tube.

If the image produced by the optical system 15 is reversed as in the case of an ordinary projector, this may be compensated by optical or electrical means so that a final upright and right-sided image is obtained on the projection screen. Thus for instance, the image may be reversed by the use of prisms or mirrors as is well known, or alternatively, in accordance with a further feature of my invention, the orientation of the image may be controlled by properly choosing the polarity of the deflecting voltages applied to the deflecting plates 8, 8' and 9, 9', respectively. Thus, in the case of optical projection whereby the image is reversed in the projector, the polarity of the sweep voltage moving the beam in the vertical direction should be such that the picture is being scanned from the bottom to the top so as to obtain a reversed picture on the luminous screen, which will then appear as an upright picture on the projection screen. Similarly, if the relationship of the sides of the picture is reversed this may be compensated by proper choice of the polarity of the deflecting sweep voltage moving the beam across the image, as is understood. Alternatively, the tube may be mounted in an upside-down position to obtain a reversed picture on the luminous screen which will appear as an upright picture on the projection screen. According to a further feature, I may provide reversing switches for reversing the polarity of the sweep voltages in any desired manner, such as for either direct observation of the picture through a magnifying lens or for projection by means of a projection lens, as described in more detail in my copending application entitled "Television system", filed June 13, 1934, and bearing the Serial No. 730,408.

By using a tube and an arrangement as described, operating with an anode voltage of the

order of 4000 volts and a gaseous filling consisting of a hydrogen gas, I was able to obtain a bright screen picture enabling a direct projection upon a surface of 2 x 2 meters in a darkened space. By the same apparatus, oscillographic records were possible with a recording speed up to 20 kilometers per second using a high speed lens system.

I claim:

1. A cathode ray tube for recording purposes comprising an envelope; means for producing a concentrated electron beam therein; means for deflecting said beam in two mutually perpendicular directions; an opaque screen impinged by the electrons to produce a light spot thereon, said screen being mounted at an angle to the line of direction of said beam; and electrostatic means for compensating for recording distortions produced by the inclination of said screen with respect to a viewing direction at right angle to said screen.

2. A cathode ray tube comprising an envelope; means for producing a concentrated electron beam therein; two pairs of deflecting plates arranged at right angle to each other for deflecting said beam in conjugate rectangular coordinates; an opaque screen covered with luminescent material for the electrons to strike against mounted with one coordinate at right angle and with the other coordinate inclined to the line of direction of said beam; and means for compensating image distortions produced by the inclination of said screen.

3. In a cathode ray tube as claimed in claim 2 in which the portion of said envelope enclosing said screen is of substantial spherical shape.

4. A cathode ray tube as claimed in claim 2 in which one pair of said deflecting plates is arranged with its axis parallel to and at closer distance from said screen and said other pair of deflecting plates is arranged at a further distance from said screen with its axis at an angle of 45° with said screen, and in which the distance between the plates of said latter deflecting system is greater as compared to the distance between the deflecting plates of said former system.

5. In a cathode ray tube as claimed in claim 2 including said screen being adapted to have biasing potentials applied thereto to secure a predetermined potential distribution of different zones of the screen area for compensating the effect of varying length of the cathode ray due to the inclination of said screen.

6. In a cathode ray tube as claimed in claim 2 including means for varying the cross-sectional shape of said cathode ray for compensating distortions of the shape of the luminous spot caused by the inclination of said screen.

7. In a cathode ray tube as claimed in claim 2 including means to secure an oval cross-sectional shape of said electron beam for compensating distortions of the luminous spot on said screen caused by the inclination of said screen.

8. In a cathode ray tube as claimed in claim 2 in which said luminous screen is coated upon a base of resistance material, and adapted to have electric potential applied to opposite sides of said base for securing a predetermined potential distribution over the area of said screen.

9. A cathode ray tube comprising an envelope, means for producing a beam therein, a luminous screen in the path of said beam and at an angle thereto, said screen comprising an opaque base mirrored upon the side facing said beam, and the

luminous material positioned on said mirrored face of the base.

5 10. A cathode ray tube comprising an envelope, means for producing a beam therein, a luminous screen in the path of said beam, said screen comprising a highly polished opaque aluminum base facing said beam and having the luminous material positioned on said polished face.

10 11. A cathode ray tube for recording purposes, comprising an envelope, means for producing a concentrated electron beam therein, means for deflecting said beam in two mutually perpendicular directions, an opaque screen covered with luminescent material for the electrons to strike against to produce a light spot thereon, means to support the screen at an angle to the direction of said beam, said screen being adapted to have electric biasing potentials applied thereto to prevent the flow of back current from the screen.

15 20 12. A cathode ray tube for recording purposes, comprising an envelope, means for producing a concentrated electron beam therein, electrostatic

means for deflecting said beam in two mutually perpendicular directions, an opaque screen covered with luminescent material for the electrons to strike against to produce a light spot thereon, means to support the screen at an angle to the direction of said beam, said screen being adapted to have electric biasing potentials applied thereto to prevent the flow of back current from the screen.

5 10 15 20 13. A cathode ray tube comprising an envelope, means for producing a concentrated electron beam therein, means for deflecting said beam in mutually perpendicular directions, a target electrode, means for supporting the target electrode at an angle to the line of direction of the electron beam, and means to develop a potential difference between the beam producing means and the target electrode, said potential difference being of a magnitude progressively changing in accordance with the distance between the elemental areas of the target and the beam producing means.

MANFRED VON ARDENNE.