

Sept. 11, 1928.

1,683,651

F. BOVARD

PROCESS FOR MANUFACTURING MATCH PACKAGES

Filed Jan. 19, 1927

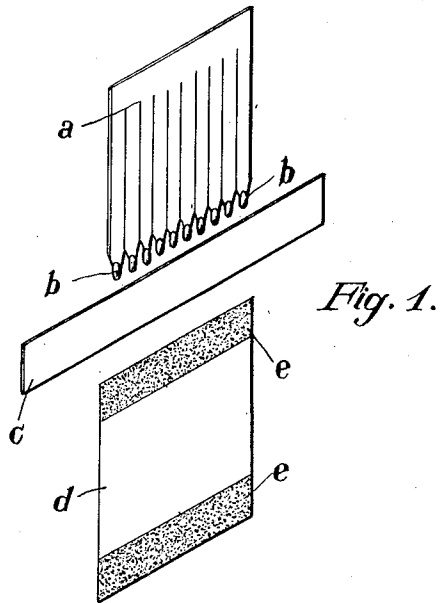

Fig. 1.

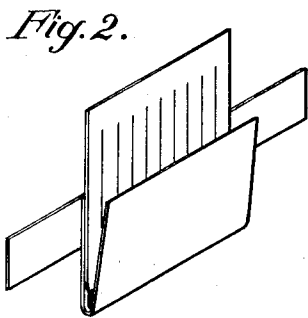

Fig. 2.

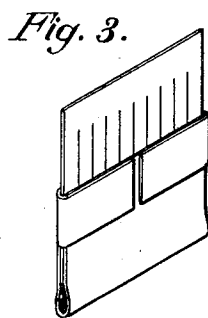

Fig. 3.

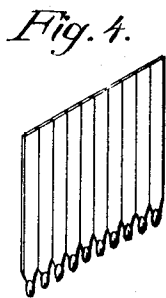

Fig. 4.

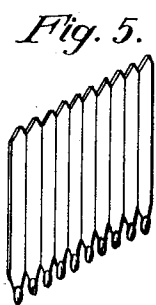

Fig. 5.

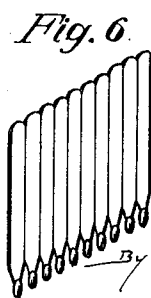

Fig. 6.

F. BOVARD
INVENTOR

By: *Marion T. Clark*
ATTY.

UNITED STATES PATENT OFFICE.

FRITZ BOVARD, OF BERN, SWITZERLAND.

PROCESS FOR MANUFACTURING MATCH PACKAGES.

Application filed January 19, 1927. Serial No. 162,196.

The present invention relates to a manufacturing process of match packages arranged in such a way that a single match will be ignited when one is withdrawn from the wrapper.

5 Packages for loose matches have been known heretofore where the match splints tipped with the ignition paste were held between rubbing surfaces in such a way that the matches will be ignited when they are with-
 10 drawn singly from between said rubbing surfaces. Now by far the largest part of such packages are intended for refilling and this fact gives the danger of some unwanted igni-
 15 tion and explosion during the refilling operation. This danger together with the necessity of repeating the refilling very frequently tends to prevent such packages finding favour with the consumers. Certain other packages
 20 of this kind however which were using ready made supply splints, required so much additional manual labor in order to overcome the danger of self-ignition that the sale of them did not pay. The consumers and especially the smoking people rather preferred the
 25 match packages in book form which were given to them gratuitously and this fact formed an additional reason for the complete disappearance of the match packages intended for re-filling.

30 It is the object of the present invention to provide a process of manufacturing match packages where the manufacturing costs are so low that the packages will cost considerably less than heretofore known packages in
 35 book form and that the new packages will likewise be adapted for presents and owing to their cheap manufacturing cost will be qualified as effective advertising objects.

The new process consists in enclosing a
 40 leaf formed of a row of sheet of paper folded on a median line and carrying two surfaces coated with the ignition paste and in separating the said splints completely only after they have been held together by said sheet.
 45 By this process the number of operations in manufacturing is greatly reduced and the tipped leaves form elements easily handled by mechanical means. The splints while kept assembled by the sheet of paper may be separated completely afterwards without danger
 50 and owing to the stiffness of the wrapper will easily stand any handling.

The accompanying drawing represents the

different phases of the process according to the present invention.

Fig. 1 is a view of the separated elements of the package.

Fig. 2 shows the package not quite assembled.

Fig. 3 shows the wrapper assembled but the separated splints still cohering, and

Figs. 4 to 6 represent different modes of cutting the leaves for separating the splints completely.

Referring to Figs. 1 to 3 *a* is a thin wooden leaf having the tips *b* of the single matches cut out and provided with ignition paste. The single matches are partly separated by slitting which is preferably done with a circular knife having as many blades as there
 65 are slits to be made.

c is a strong paper band and *d* a paper wrapper provided with two stripes *e* of ignition paste. The band is pasted to one side of the wrapper and the leaf *a* laid on the
 70 other side of the wrapper which is then folded on a median line so as to enclose the leaf as shown in Fig. 2. The ends of band *c* are then bent over the free half of the wrapper
 75 *d* and pasted thereto and thus the band encompasses the leaf completely. The wrapper while tightly closing about the shafts of the splints will leave the tips of the splints free to a certain extent.

As in this state of manufacturing the
 80 wrapper would be useless it is then necessary to separate the single splints completely from each other. This may be done in different ways. According to Fig. 4 the slits are cut through unto the edge of the leaf by means of
 85 the same circular knives mentioned here above. According to Fig. 5 however the upper cohering portion of the leaf is cut off by means of corrugated scissors or as shown in
 90 Fig. 6 a suitably shaped cutter is employed to cut off the cohering portion of the leaf and to mark the single splints with curved ends. By this means the adjacent protruding ends of the match strip are so formed that a match
 95 can be more easily separated from an adjacent one by the user.

When the leaves are made in any of these different ways the result will ever be the same, to wit, to effect the complete separation
 100 of the splints, so that they may be withdrawn singly from the wrapping and in so with-

drawing become ignited. It is possible to assemble also several packages into one package by means of a common band and then the single leaves of splints may be cut at different heights so that there are several rows of matches whereof the single splints may be easily withdrawn.

What I claim and wish to secure by Letters Patent is:

10 1. A method of manufacturing match packages containing at least one sheet of single splints, consisting of partially cutting a sheet of material to form a sheet of splints connected at one edge thereof, applying to 13 the free ends of splints a match composition, securing such sheet of splints at the free ends of said splints frictionally between a folded sheet of material provided with an ignition paste along free edges thereof, cut-

ting said uncut edge of the sheets of splints by 20 cuts continuing the first mentioned cuts through to the edge.

2. A method of manufacturing match packages containing at least one sheet of single splints, consisting in partially cutting 25 a sheet of material to form a sheet of splints connected at one edge thereof, applying to the free ends of splints a match composition, securing such sheet of splints at the free ends of said splints frictionally between a folded 30 sheet of material provided with an ignition paste along free edges thereof, cutting-off said uncut edge of the sheet of splints by means of a suitable cutter so as to mark the single splints with curved ends. 35

In testimony whereof I affix my signature.

FRITZ BOVARD.