

Oct. 10, 1933.

J. T. BEAGAN

1,930,378

BABY'S SAFETY STRAP AND HARNESS

Filed April 3, 1931

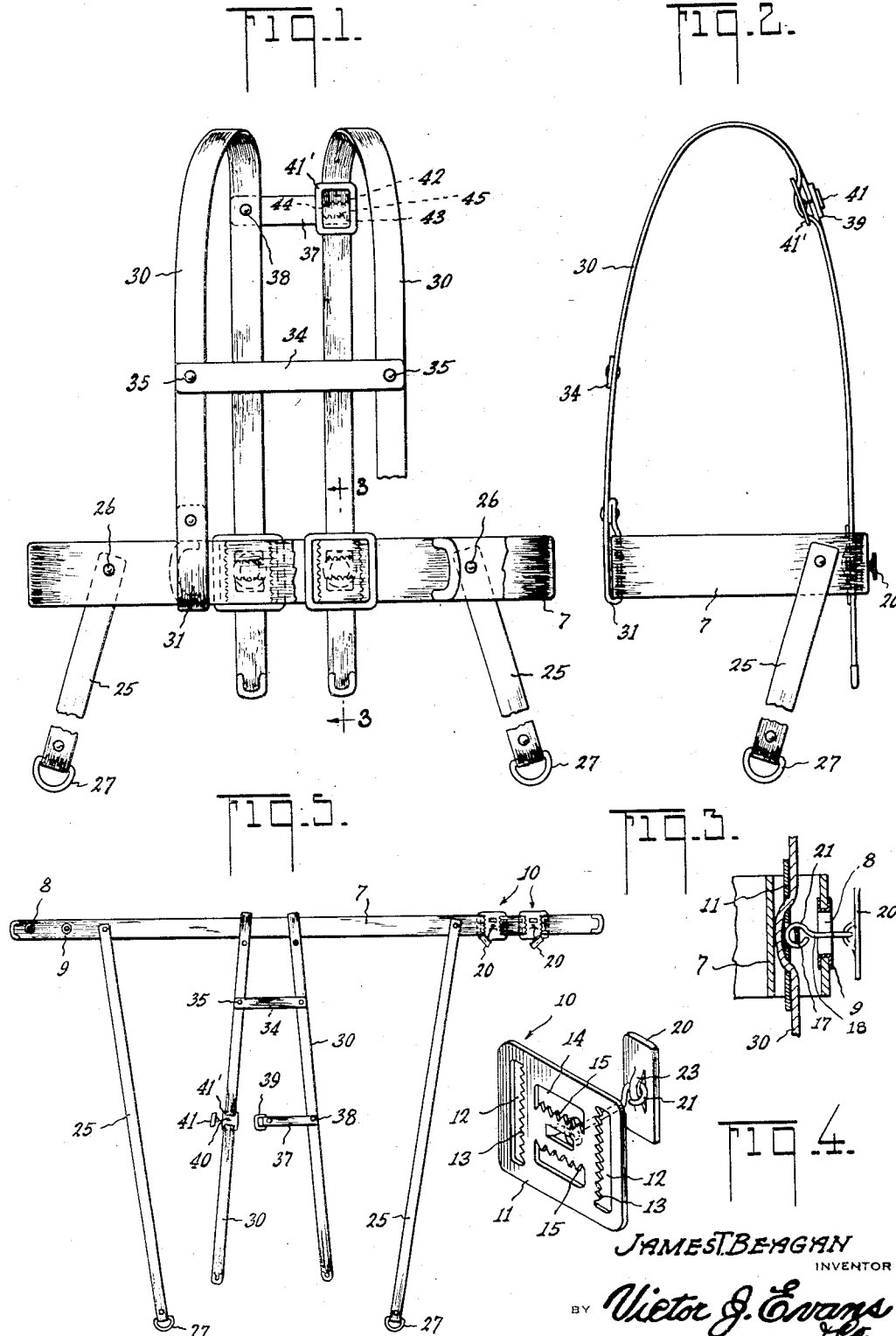

WITNESS  
*J. Mank*

JAMES T. BEAGAN  
INVENTOR  
BY *Victor J. Evans*  
ATTORNEY

# UNITED STATES PATENT OFFICE

1,930,378

## BABY'S SAFETY STRAP AND HARNESS

James T. Beagan, Brooklyn, N. Y.

Application April 3, 1931. Serial No. 527,509

1 Claim. (Cl. 155—189)

This invention relates to a safety strap and harness construction intended to hold a baby in a chair, carriage or other place of rest.

An object of my invention is the provision of a device of the character mentioned which is an improvement on that shown, described and claimed in my prior Patent No. 1,897,882, issued Feb. 14, 1933.

Other objects will be appreciated upon reading the following specification.

The invention will be fully and comprehensively understood from a consideration of the following detailed description when read in connection with the accompanying drawing which forms part of the application, with the understanding, however, that the improvement is capable of extended application and is not confined to the exact showing of the drawing nor to the precise construction described and, therefore, such changes and modifications may be made therefrom as do not affect the spirit of the invention nor exceed the scope thereof as expressed in the appended claim.

In the drawing:

Fig. 1 is a front view of my improved device, partly broken away.

Fig. 2 is an end view of the device shown in Fig. 1.

Fig. 3 is a vertical section taken on line 3—3 of Fig. 1.

Fig. 4 is a perspective view of a buckle employed in the device and shown in section in Fig. 3; and

Fig. 5 is a plan view of the device in open position.

Referring to the drawing for a more detailed description thereof, numeral 7 indicates a waistband intended to go around the waist or the body of a child. At one end portion of the waistband there is a pair of apertures 3 encircled by grommets 9. At the other end portion of the waistband there is a pair of buckles 10 of similar construction, the construction being shown in detail in Figs. 3 and 4. The buckles 10 comprise plates 11 having apertures 12 therein. A serrated edge 13 comprising a plurality of teeth is provided adjacent each of the apertures 12. The plates 11 are also provided with apertures 14 at right angles to the apertures 12, and the apertures 14 are also provided with a serrated edge 15 comprising a plurality of teeth. The members 11 are provided with pressed-out portions 17 to which are secured links 18 adapted to swing on the portions 17. Retaining means 20 in the form of elongated

rectangular plates are swingably secured to the links 18. The retaining means or plates 20 are secured to the links by having looped portions 21 of the links pass through pressed-out portions 23 of the plates 20 as clearly shown in Fig. 4. When the ends of the waist band are secured together the links 18 pass through the apertures 3 and the retaining means or plates 20 hold the links in the apertures. The plates 11 are held to the waistband by having the latter pass through one of the slots 12 in one direction and through the other slot 12 in the other direction as shown in Fig. 3, the buckles being securely held in the desired position by the teeth 13 engaging the waistband.

Retaining straps 25 are secured to the waistband at the rear thereof by any suitable fastening means such as rivets 26. The straps 25 are provided at their free ends with rings 27. The straps 25 are intended to be looped around a part such as an arm for example of a seat or carriage and the rings 27 are adapted to be engaged by the links 18 and the retaining means or plates 20 of the buckles 10.

A pair of shoulder straps 30 are each slidably secured to the waistband 7 at one end by having looped portions 31 go around the waistband transversely. The other end portions of the shoulder straps 30 pass through the buckles 10, going through one of the apertures 14 in one direction and through the other aperture 14 in the opposite direction, the straps being held in any desired position by the toothed edge 15. A transverse strap 34 is secured to the straps 30 by any suitable means such for example as rivets 35. Another cross or transverse strap 37 is secured to one of the shoulder straps 30 by any suitable means as for example by rivets 38. The strap 37 has a ring 39 at one end as clearly shown in Fig. 5 and this ring is adapted to be detachably engaged by a link 40 and a plate 41 secured to the link 40. The link 40 is secured to a buckle 41' provided with apertures 42 and 43 through which one of the shoulder straps 30 passes in opposite directions, being held in place by serrated edges 44 and 45 provided adjacent the apertures 42 and 43, respectively.

It will be readily appreciated from the foregoing description that I have provided in the present application a structure which in several ways is an improvement over the structure shown, described and claimed in my above mentioned prior patent.

What is claimed as new is:

A device of the kind indicated comprising a

5 waist strap and a pair of shoulder straps, a pair  
 of separately adjustable buckles formed with  
 apertures through which one terminal of the  
 waist strap is threaded and with additional aper-  
 10 tures through which the shoulder straps are  
 threaded, and a fastener loosely mounted on  
 each buckle and engageable with the other end  
 of said waist strap through eyes formed in the  
 same, the buckles comprising flat plates with  
 15 the apertures for the waist strap disposed adja-

cent the opposite ends of the plates and the aper-  
 tures for the shoulder straps disposed adjacent  
 the upper and lower edges, all of said apertures  
 being formed with series of teeth along their  
 proximal edges, and the fasteners being secured 80  
 to the parts of the plate constituting webs exist-  
 ing between the apertures adjacent their respec-  
 tive upper and lower edges.

JAMES T. BEAGAN.

15

20

25

30

35

40

45

50

55

60

65

70

75

85

90

95

100

105

110

115

120

125

130

135

140

145

150