



US007113535B2

(12) **United States Patent**
Tenzek et al.

(10) **Patent No.:** **US 7,113,535 B2**
(45) **Date of Patent:** **Sep. 26, 2006**

- (54) **INDUCTION FURNACE FOR MELTING GRANULAR MATERIALS**
- (75) Inventors: **Anthony M. Tenzek**, Hanoverton, OH (US); **David A. Lazor**, Hubbard, OH (US)
- (73) Assignee: **AJAX Tocco Magnethermic Corporation**, Euclid, OH (US)

3,696,223 A	10/1972	Metcalf et al.
4,594,723 A	6/1986	Folgero et al.
4,606,037 A *	8/1986	Terashima et al. 373/6
4,915,723 A	4/1990	Kaneko et al.
5,315,085 A *	5/1994	Ferguson 373/6
5,502,743 A *	3/1996	Conochie et al. 373/151
5,690,734 A *	11/1997	Imaeda et al. 117/18
6,361,597 B1	3/2002	Takase et al.

FOREIGN PATENT DOCUMENTS

(*) Notice: Subject to any disclaimer, the term of this patent is extended or adjusted under 35 U.S.C. 154(b) by 0 days.

JP 52061844 A * 5/1977

* cited by examiner

Primary Examiner—Tu Hoang

(74) *Attorney, Agent, or Firm*—Sand + Sebolt

(21) Appl. No.: **10/851,565**

(22) Filed: **May 21, 2004**

(57) **ABSTRACT**

(65) **Prior Publication Data**

US 2005/0259713 A1 Nov. 24, 2005

- (51) **Int. Cl.**
H05B 6/22 (2006.01)
 - (52) **U.S. Cl.** **373/151**; 373/156; 373/157; 373/59
 - (58) **Field of Classification Search** 373/5-7, 373/59, 138-142, 144, 146, 149, 151-152, 373/156-157; 117/18, 210, 214; 219/601, 219/628
- See application file for complete search history.

A continuous- or intermittent-melt induction furnace useful for heating and/or melting semi-conductor or other materials includes an induction coil, a susceptor switchable between open and closed electric circuit modes, and a crucible. The susceptor is inductively or resistively heated in the closed circuit mode and transfers heat to material in the melting cavity to make it susceptible to inductive heating. The susceptor is then switched to the open circuit mode and the susceptible material is directly inductively heated to melt remaining solid material. A cone-shaped flow guide in the melting cavity improves molten material flow to improve the ability to draw small-particle material into the melt and increase crucible life due to improved heat uniformity. A trap passage communicating with the melting cavity and an exit opening in the crucible allows the flow of material through the exit opening to be controlled by pressure differentials on either side of the trap passage.

(56) **References Cited**

U.S. PATENT DOCUMENTS

1,655,983 A	1/1928	Brace
1,782,359 A *	11/1930	Linnhoff 373/6
3,538,981 A *	11/1970	Phipps, Jr. 164/513

46 Claims, 22 Drawing Sheets

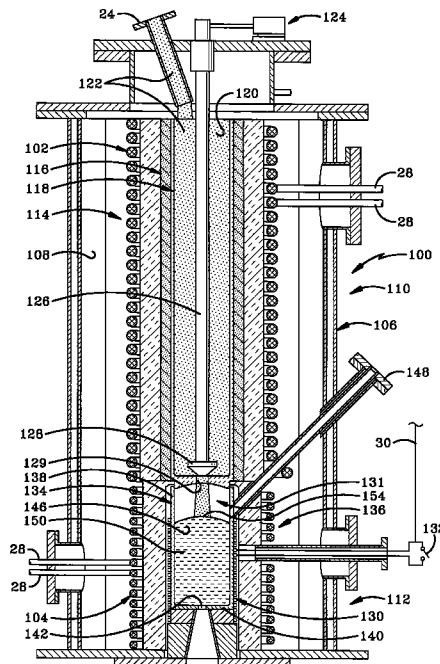

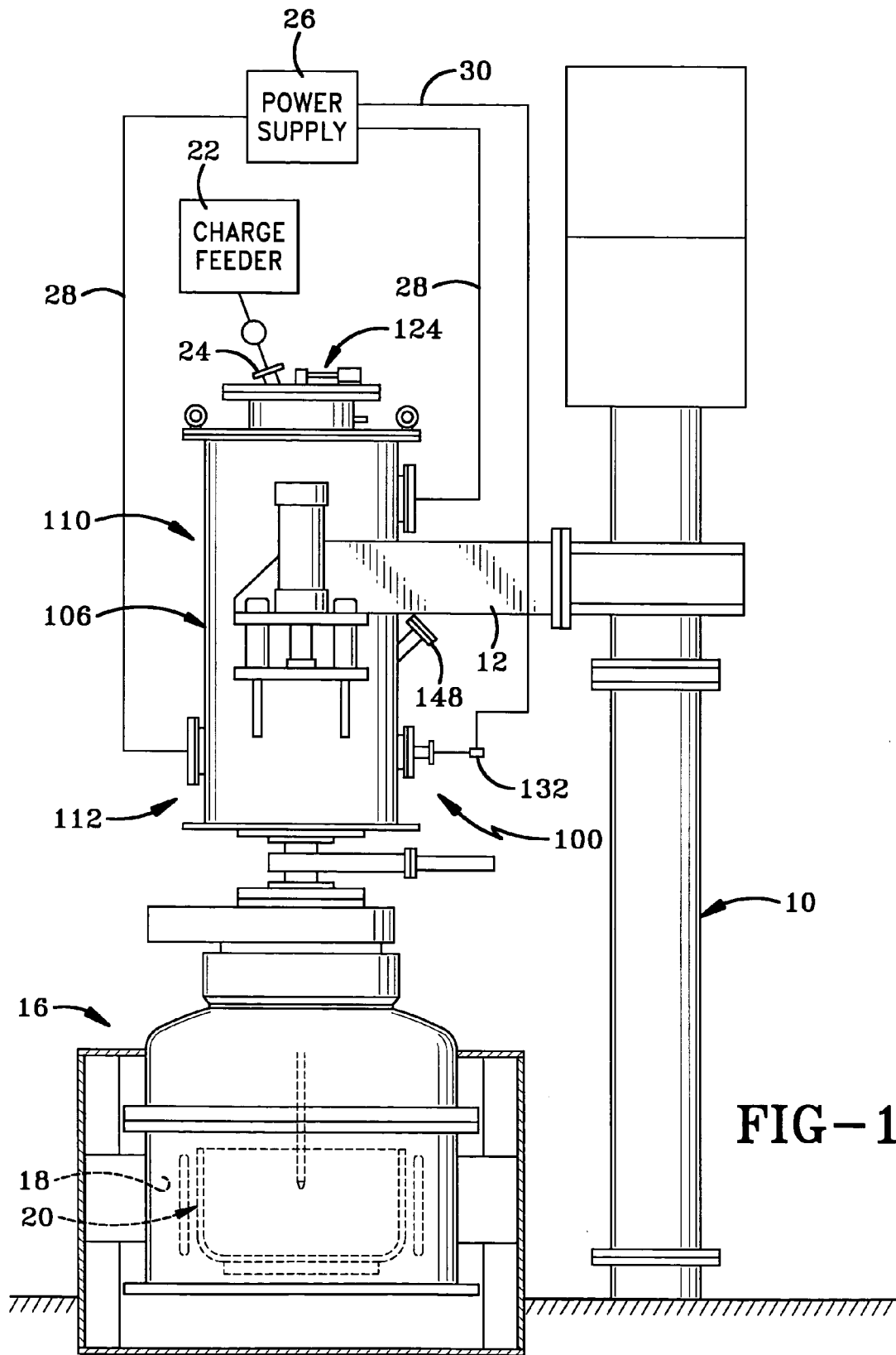

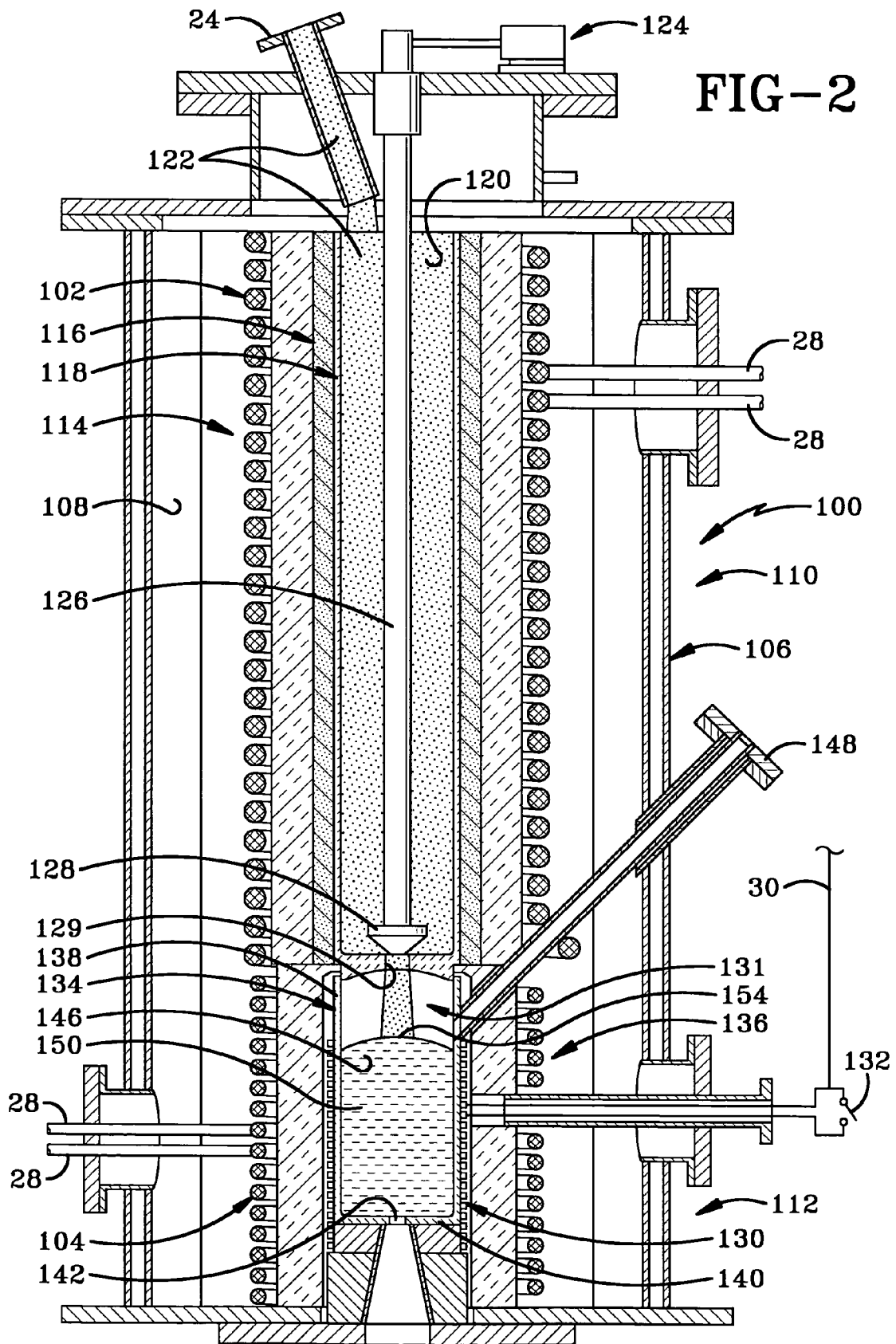

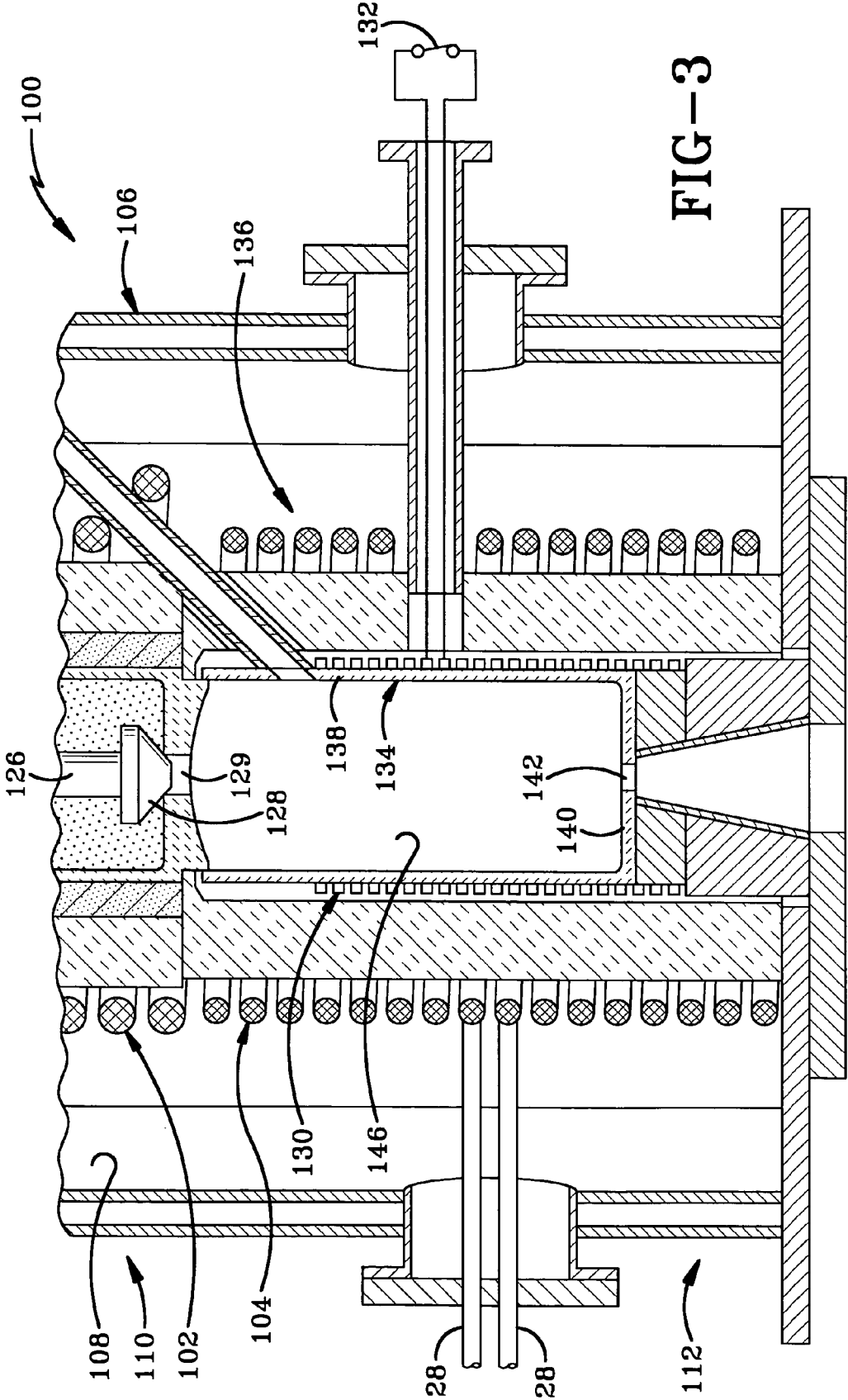

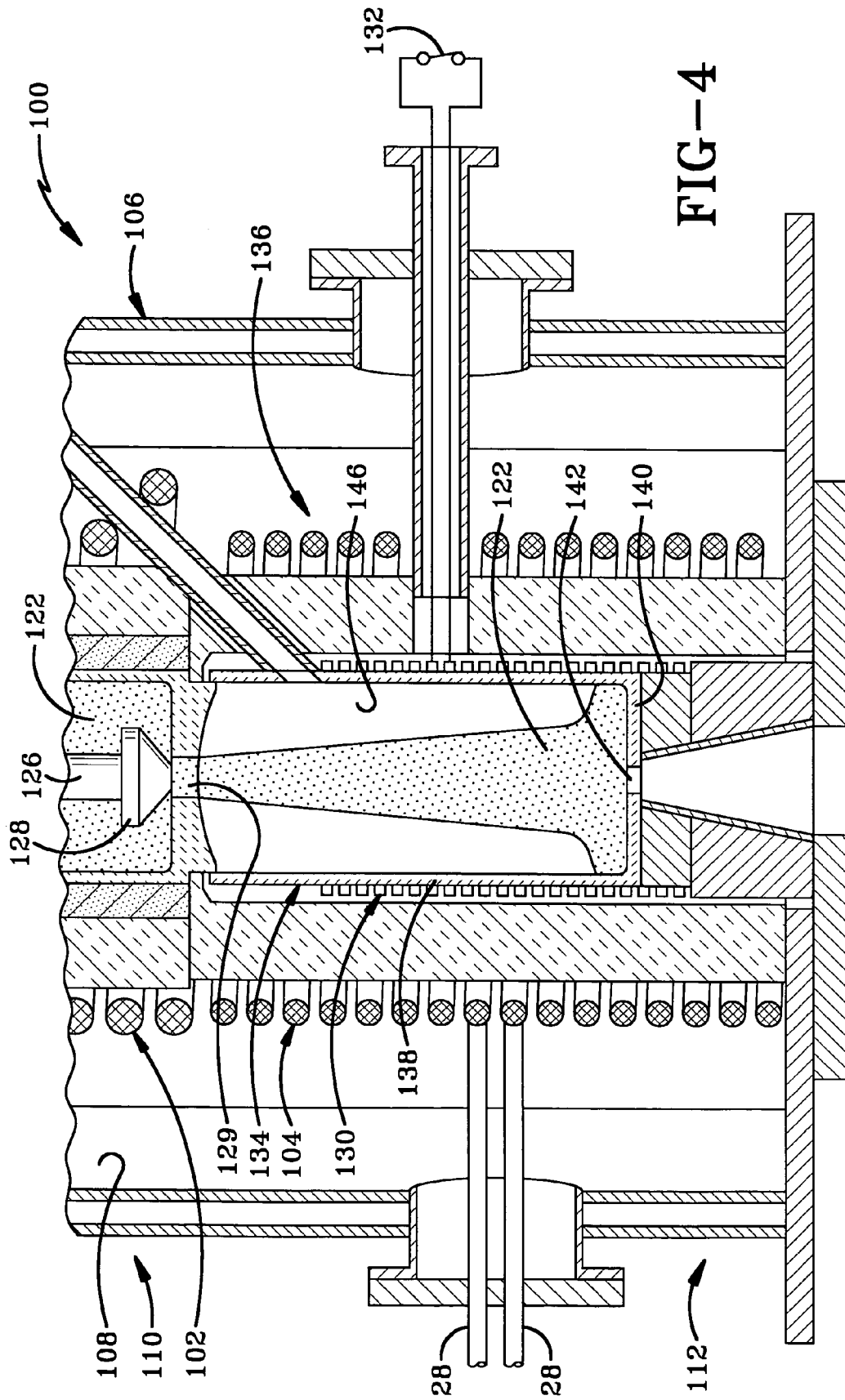

FIG-4

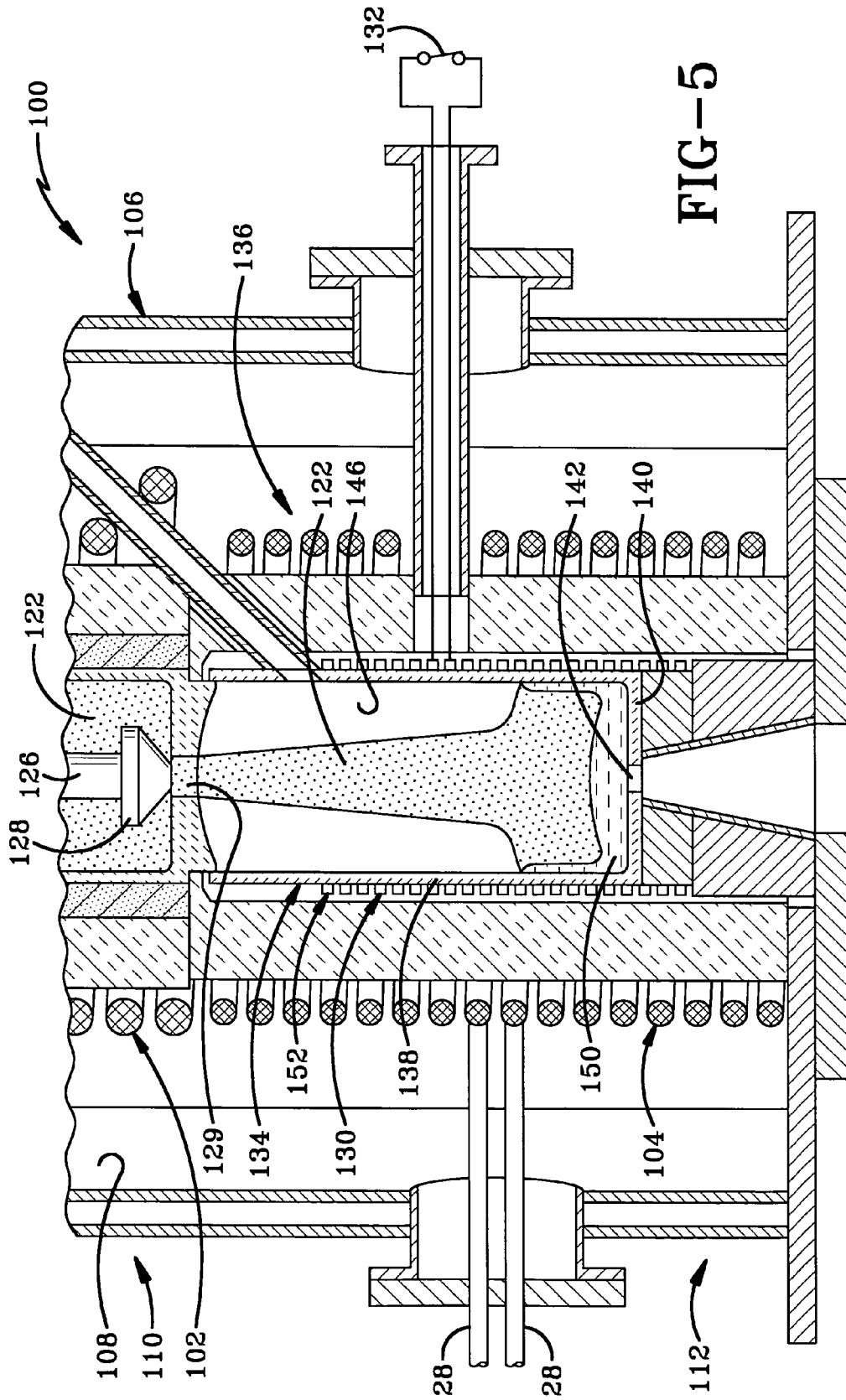

FIG-5

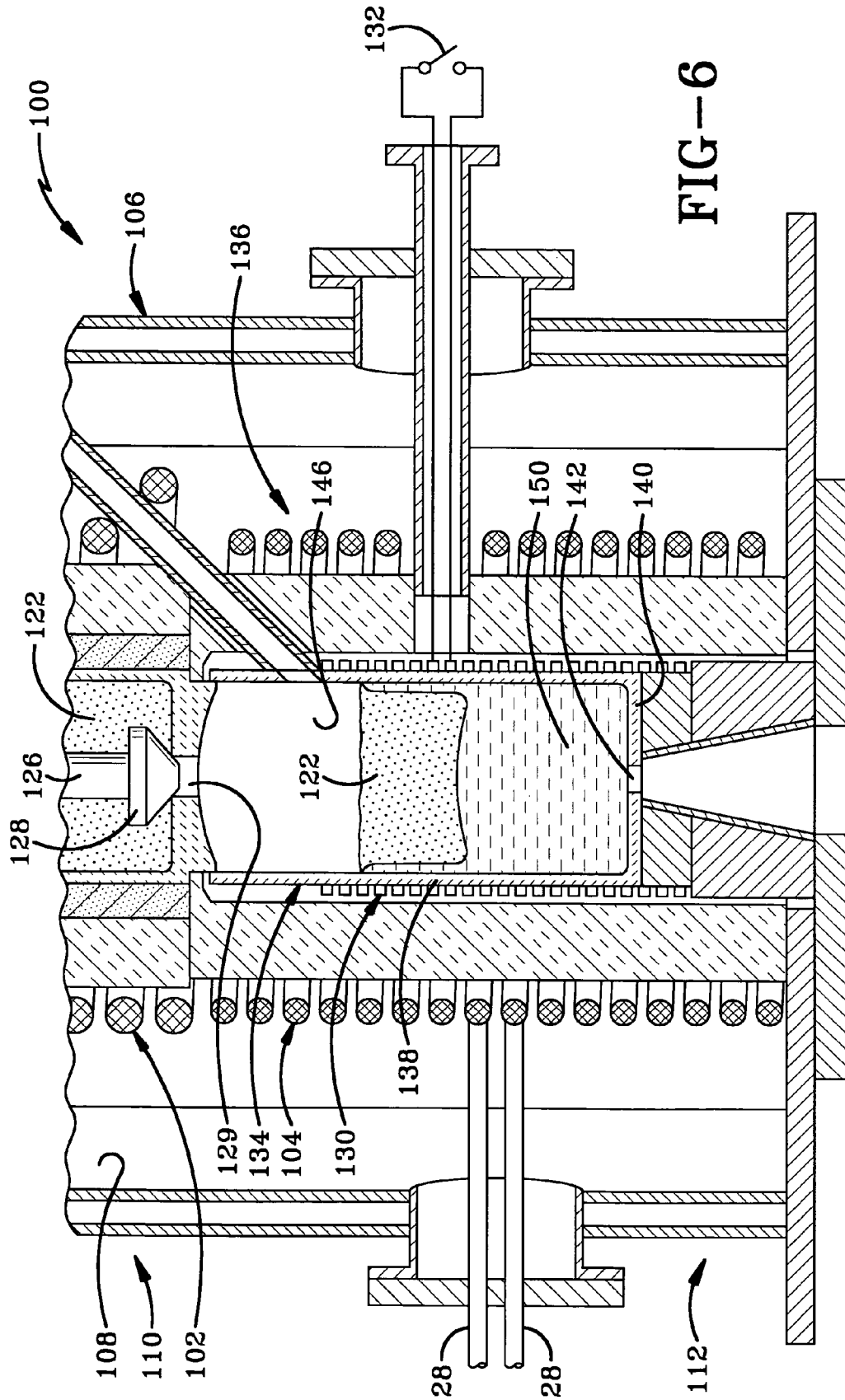
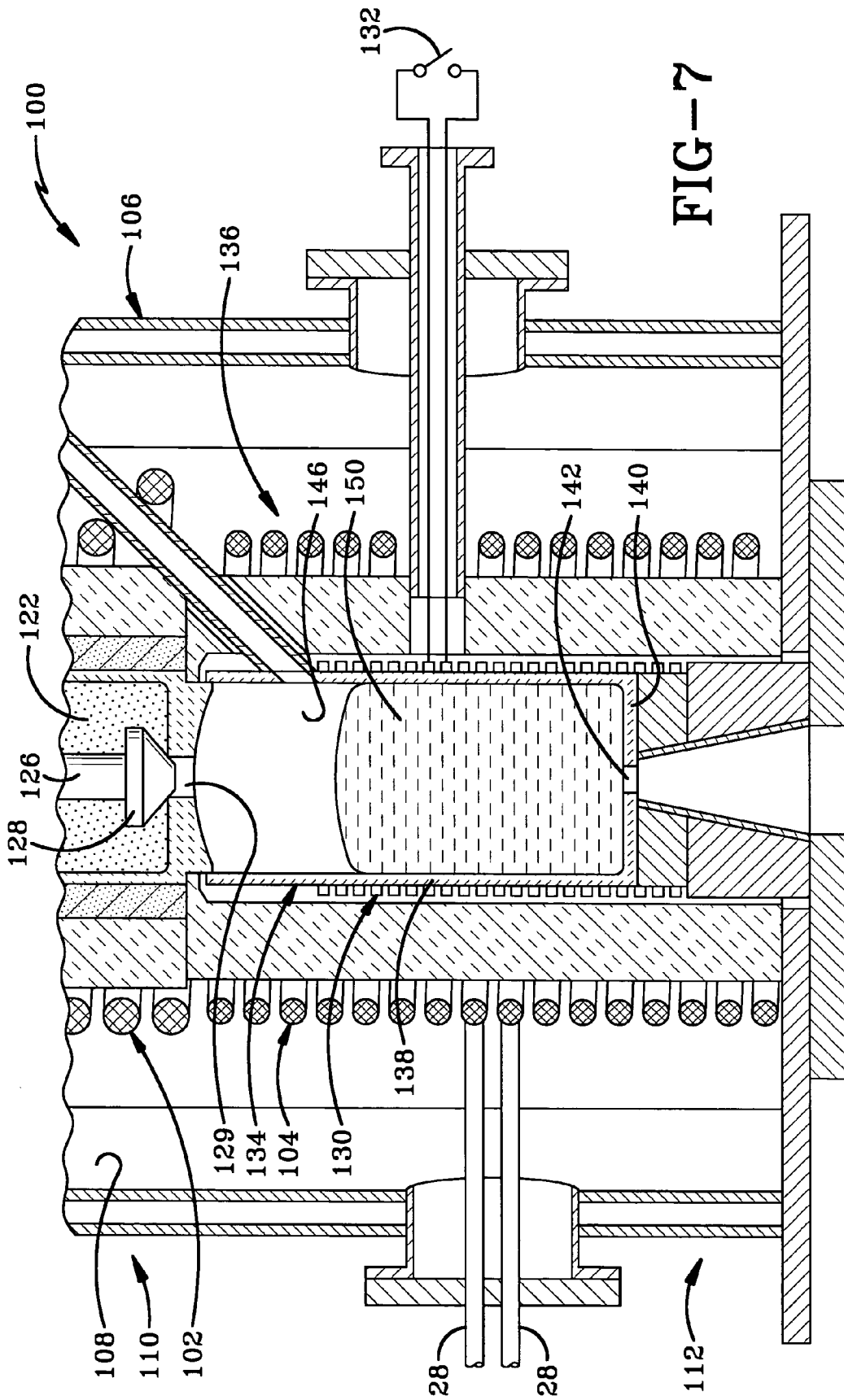

FIG-6



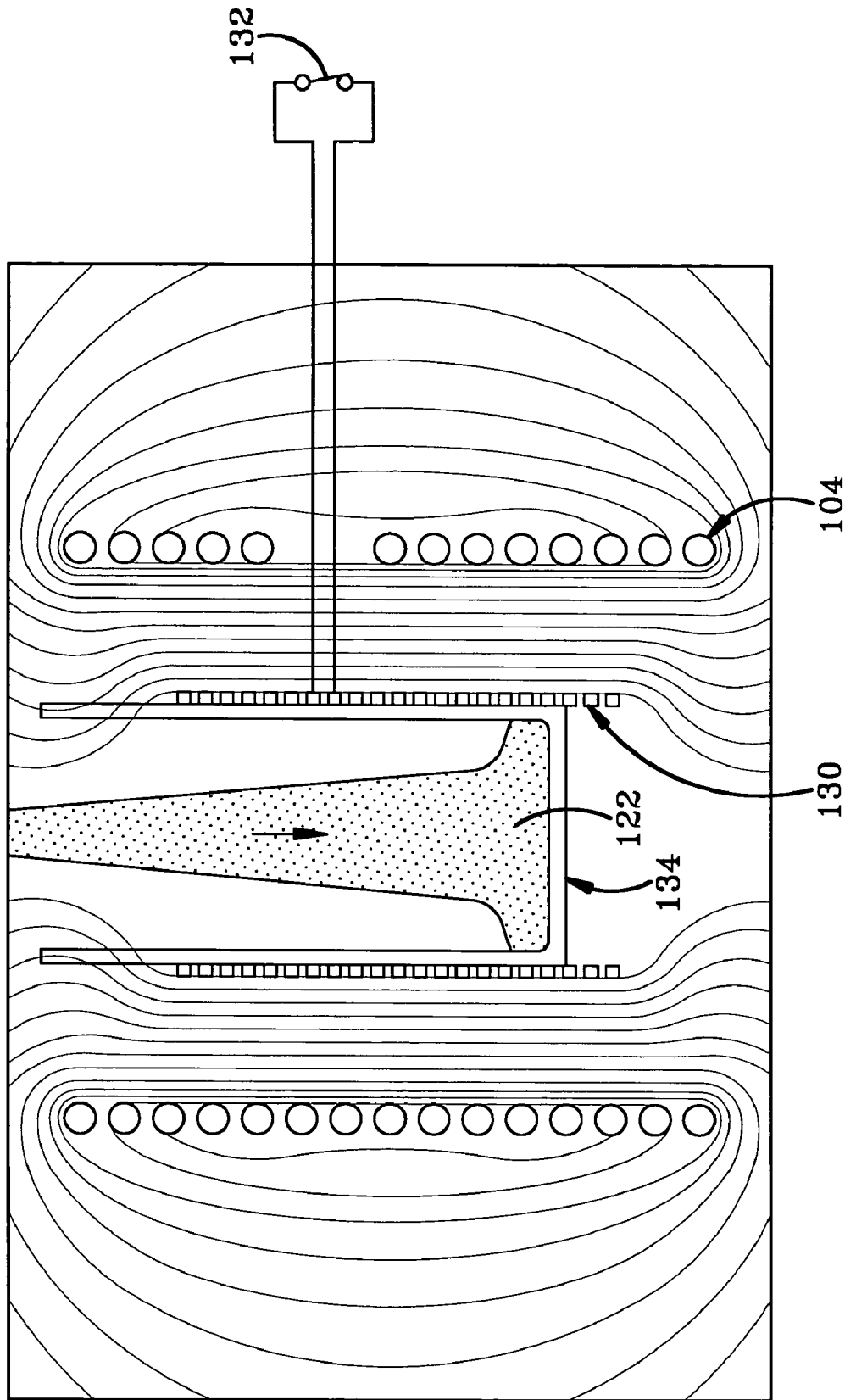

FIG-8

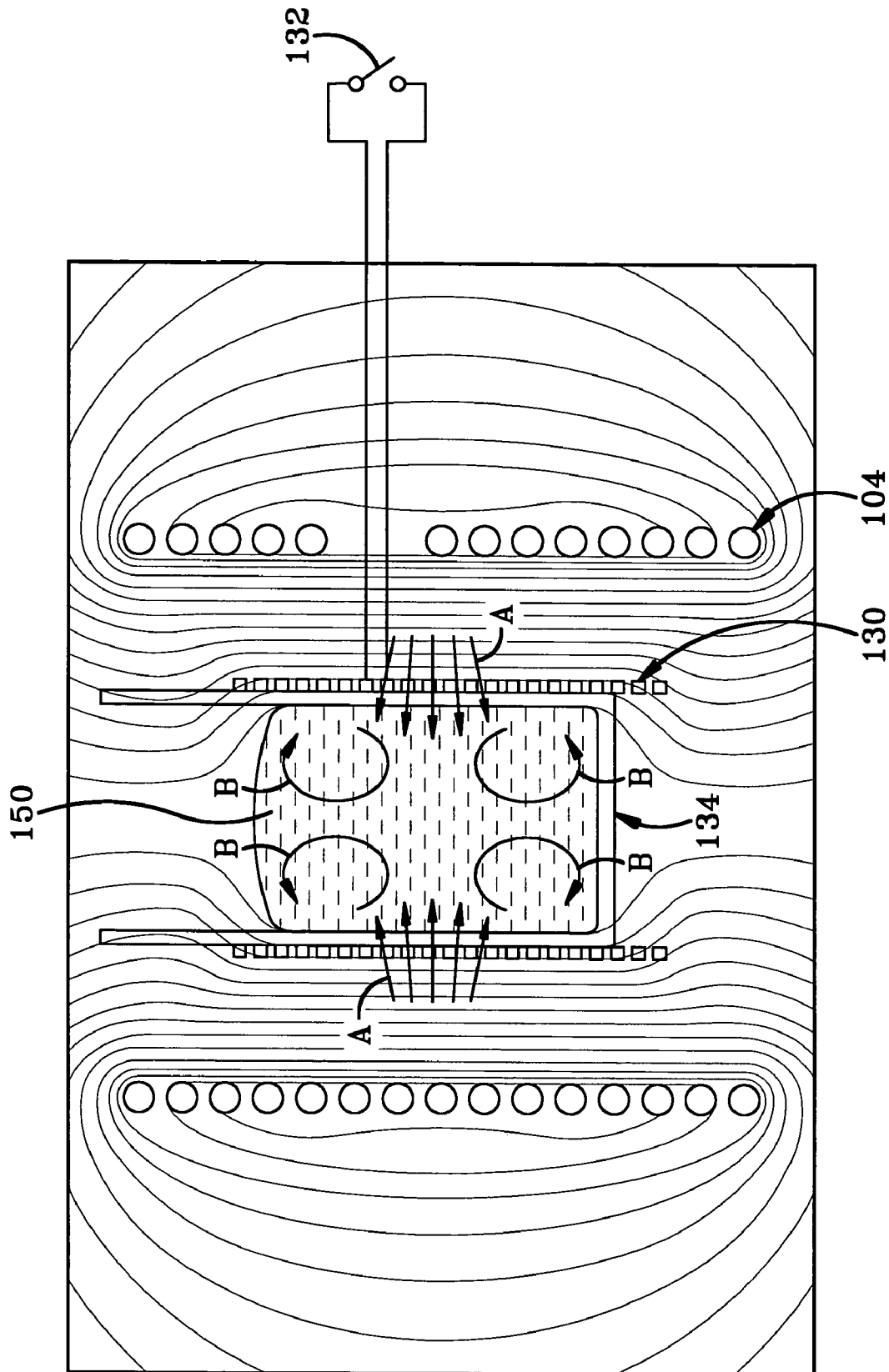
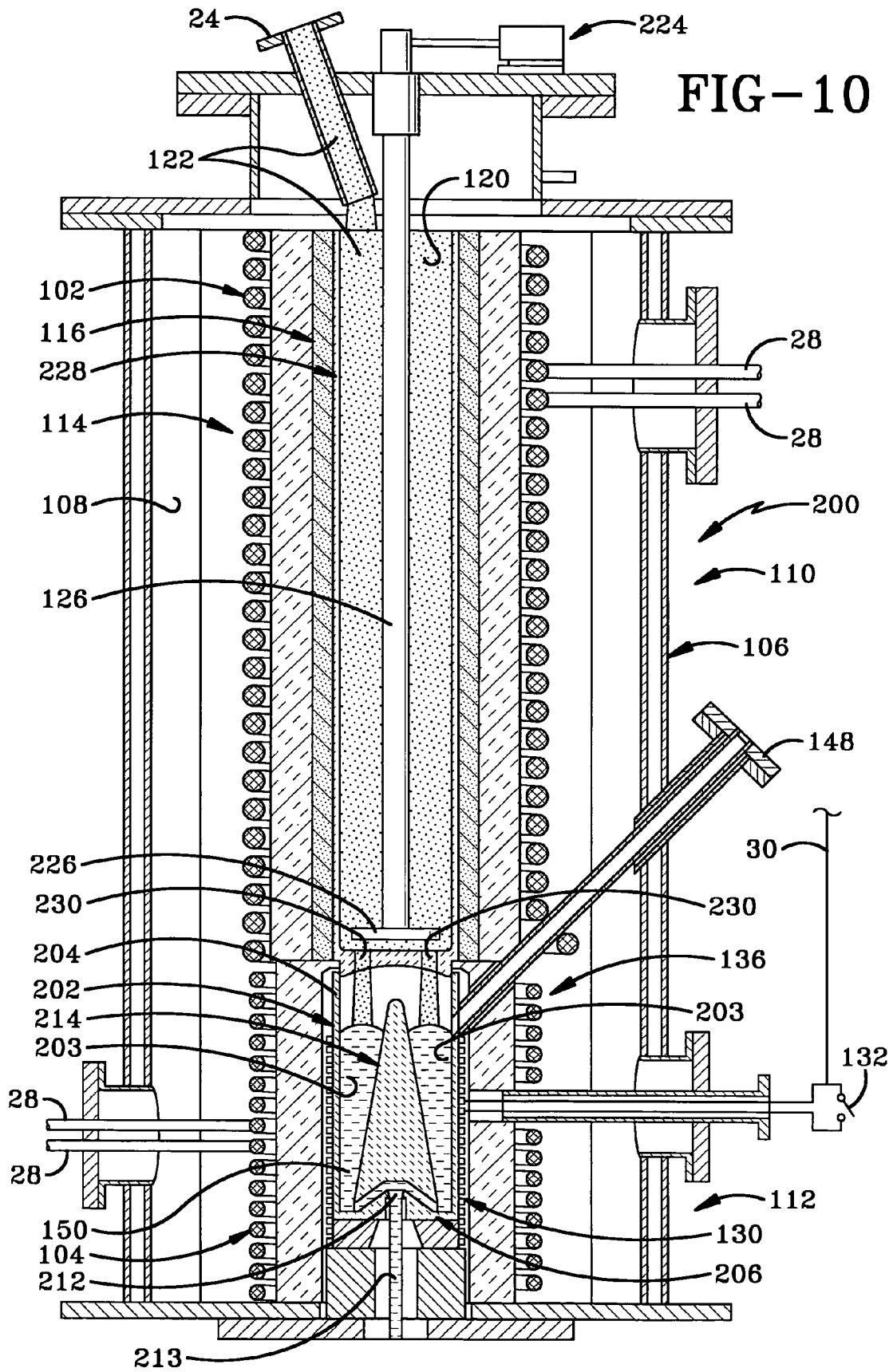
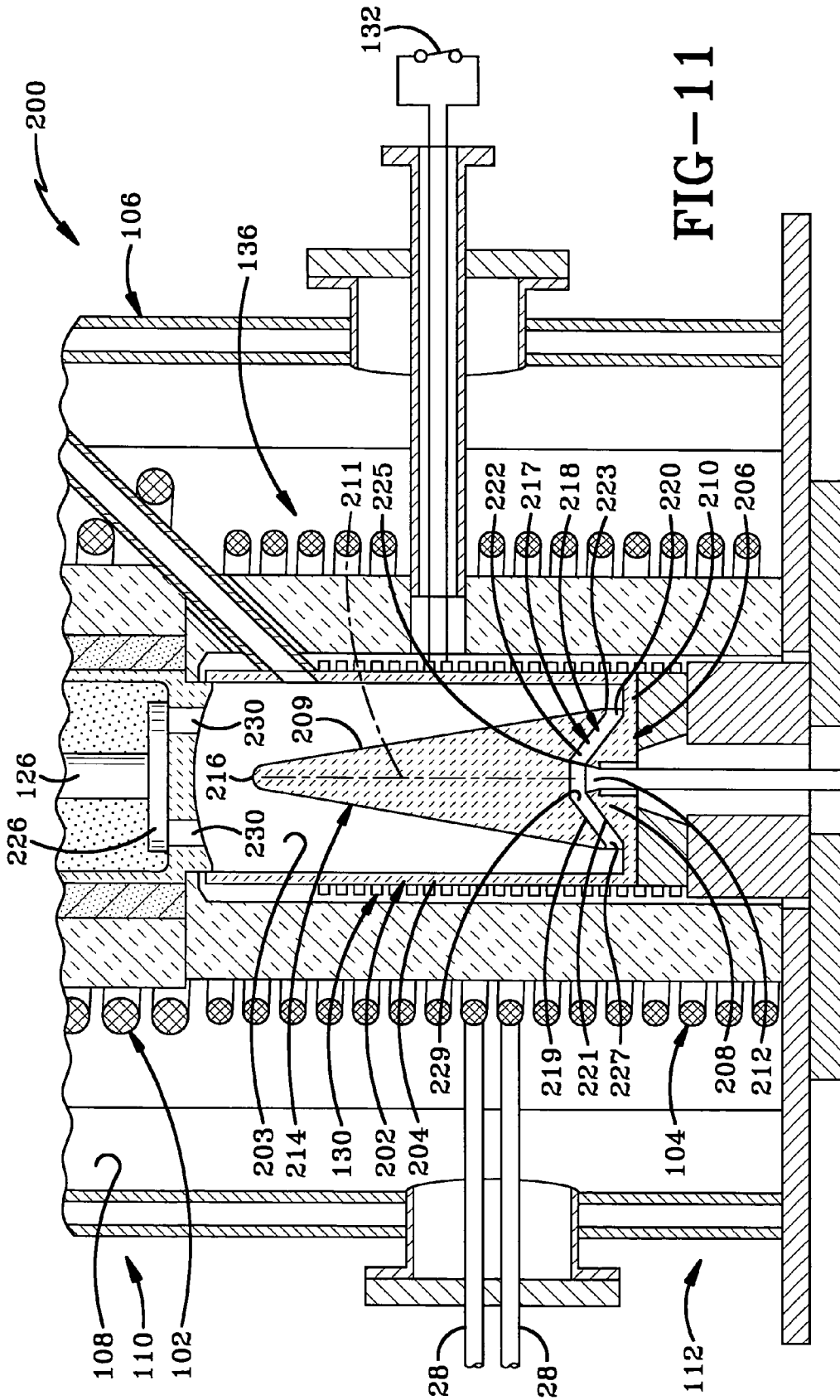
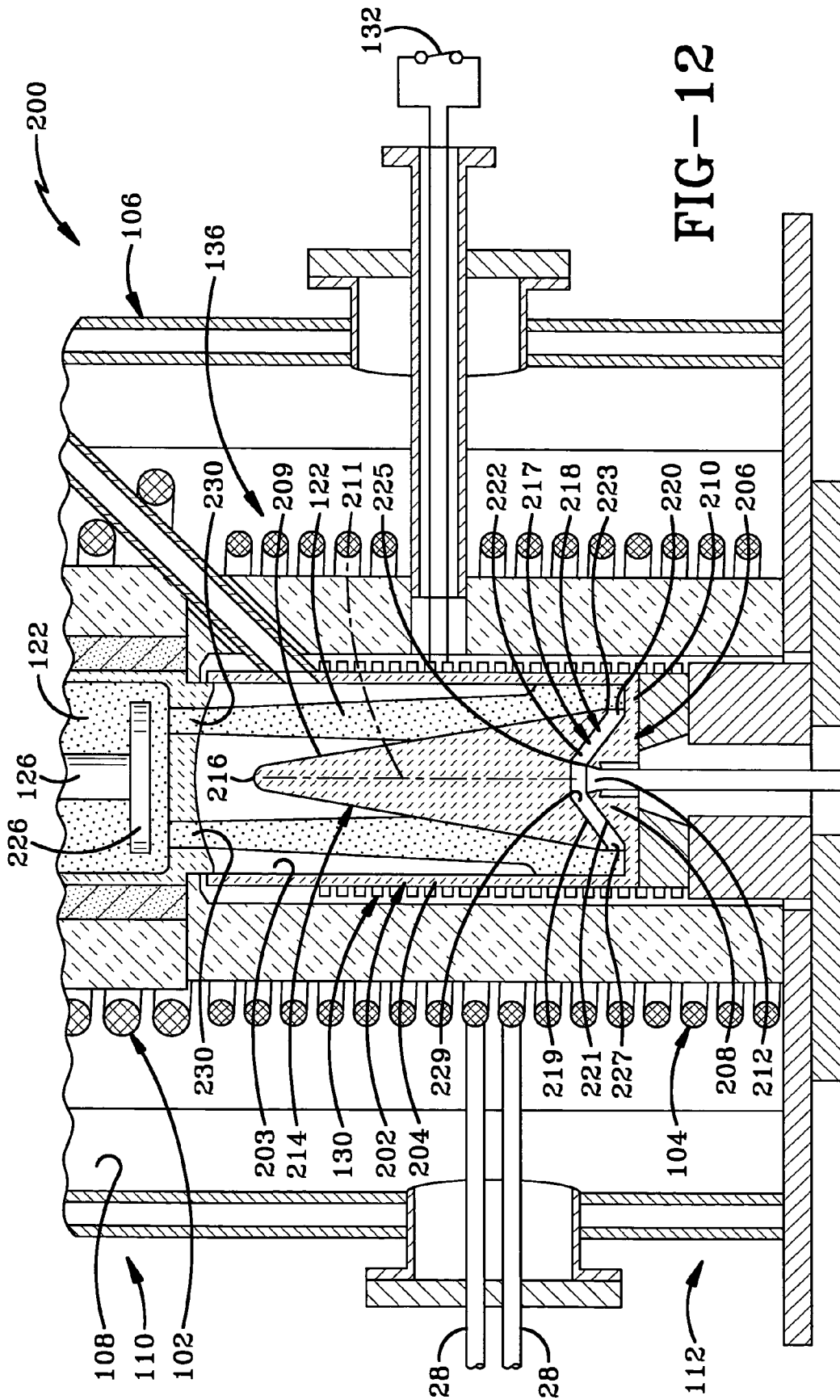
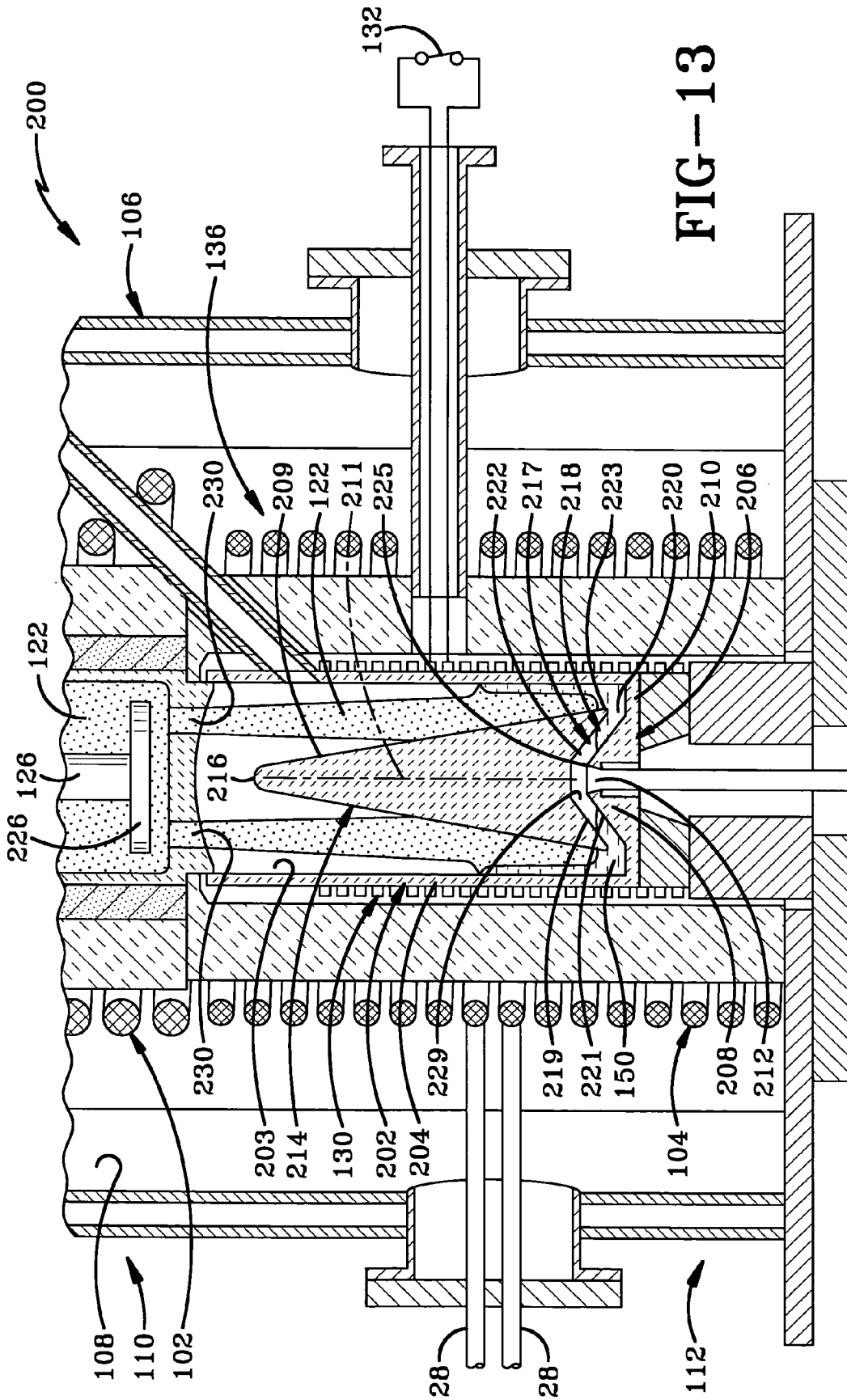

FIG-9









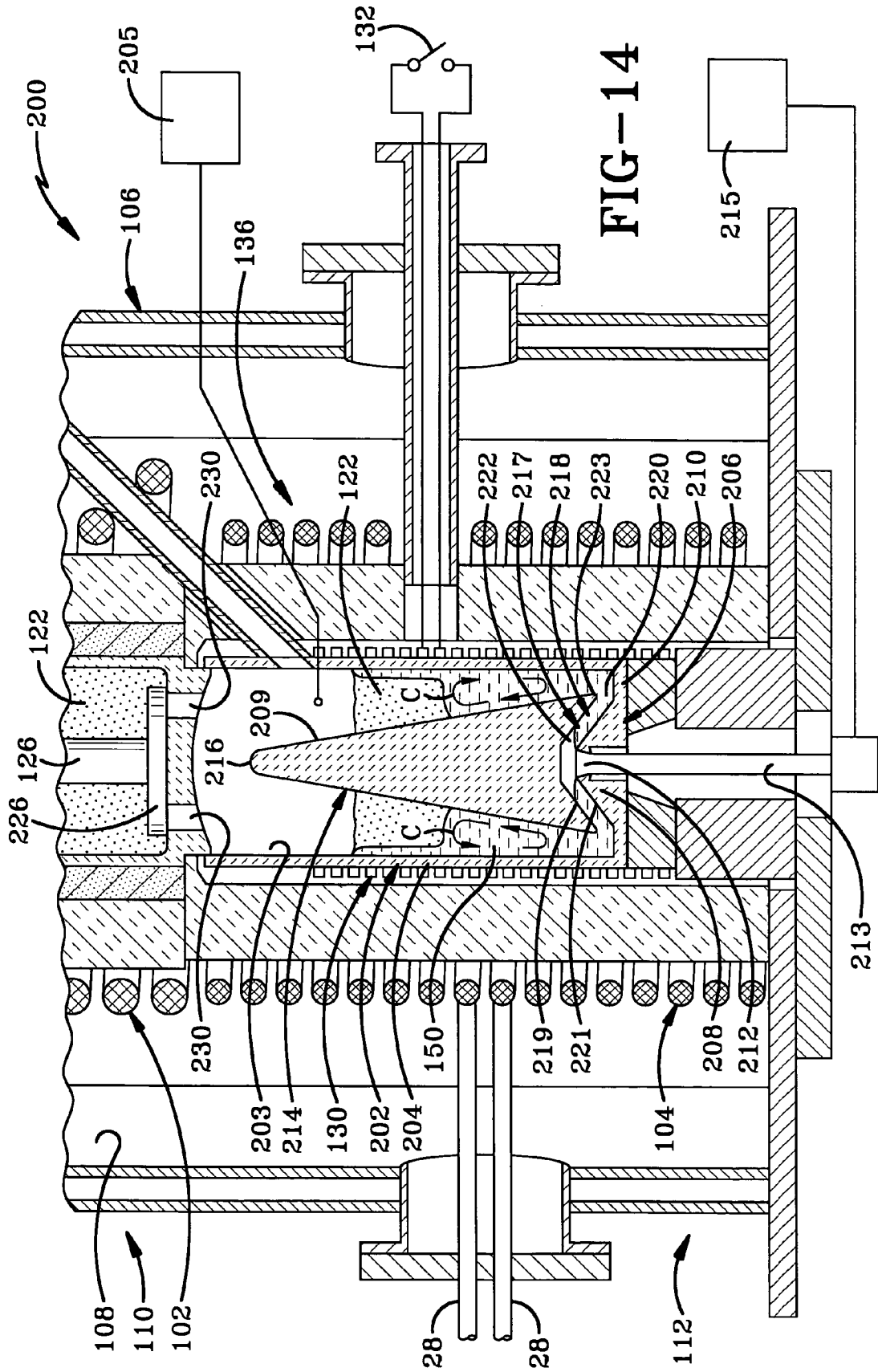

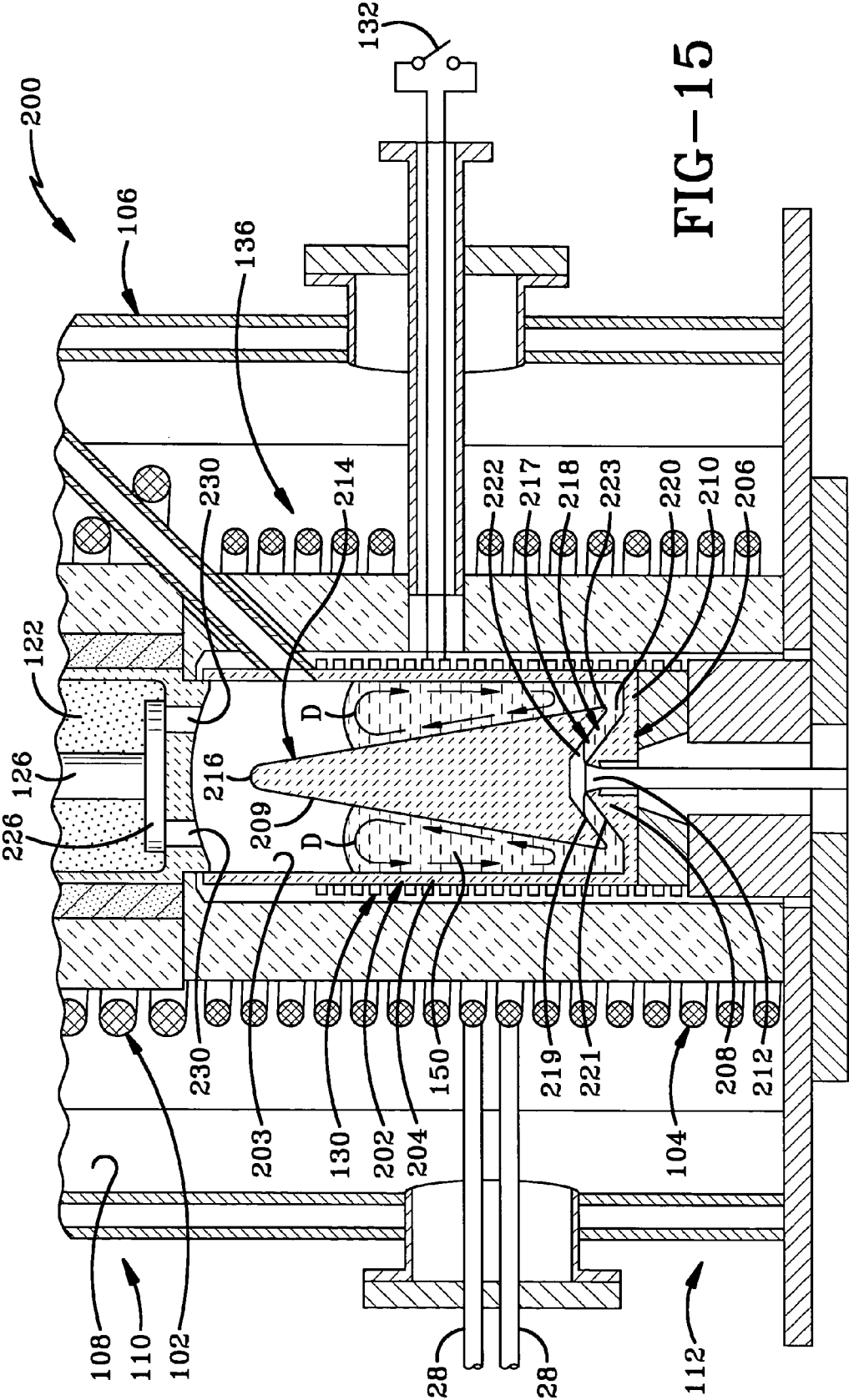
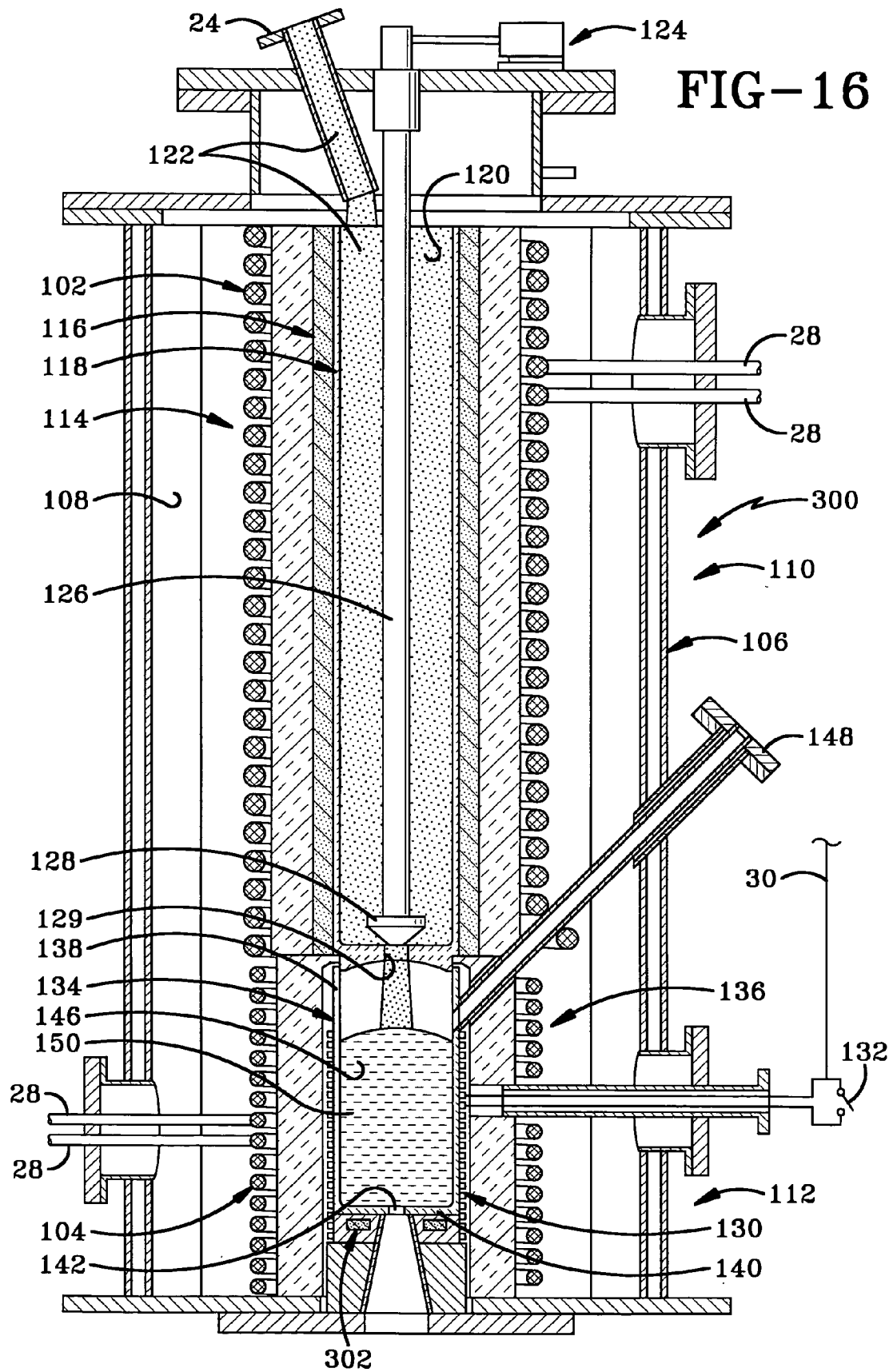

FIG-15



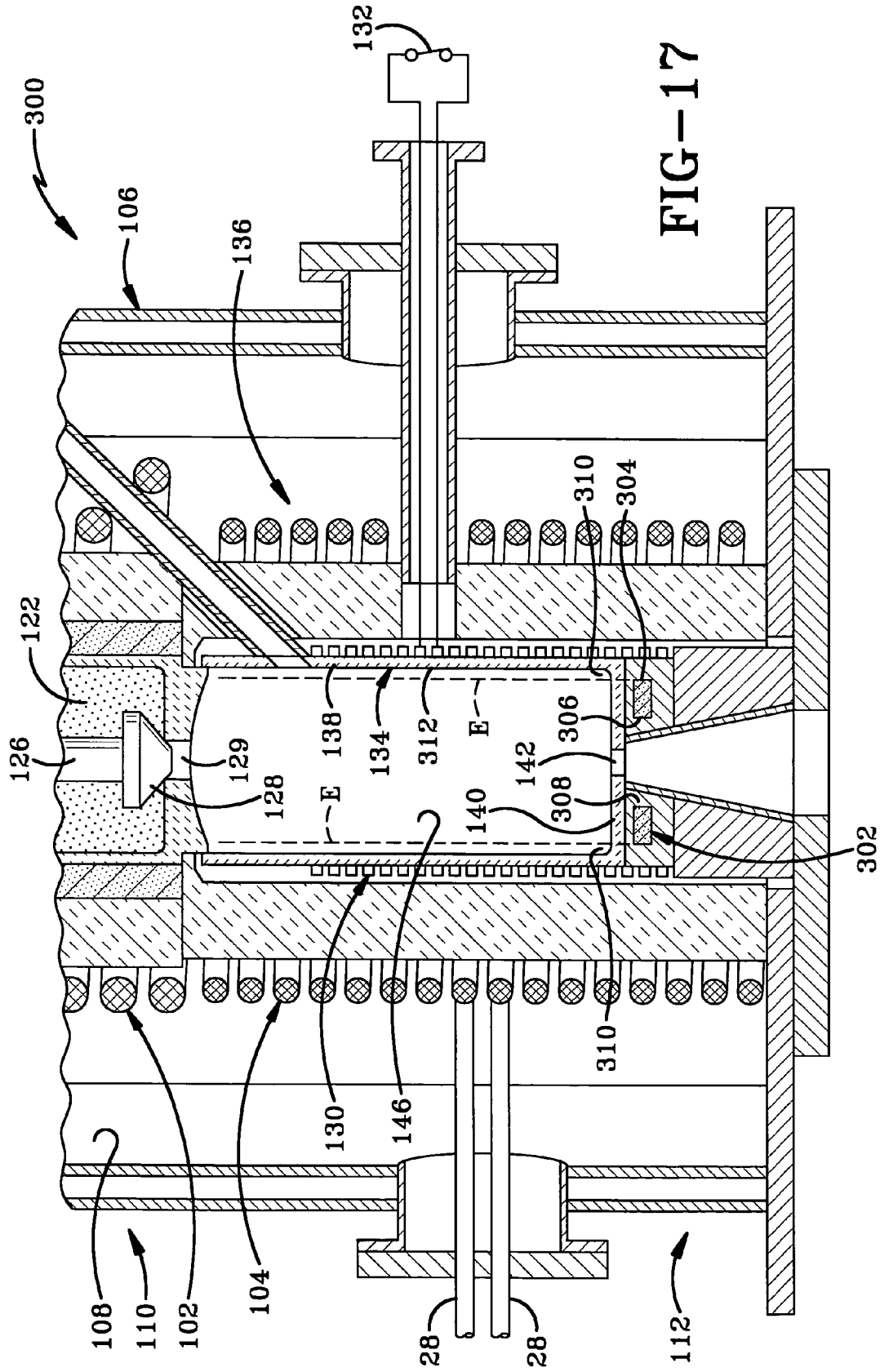
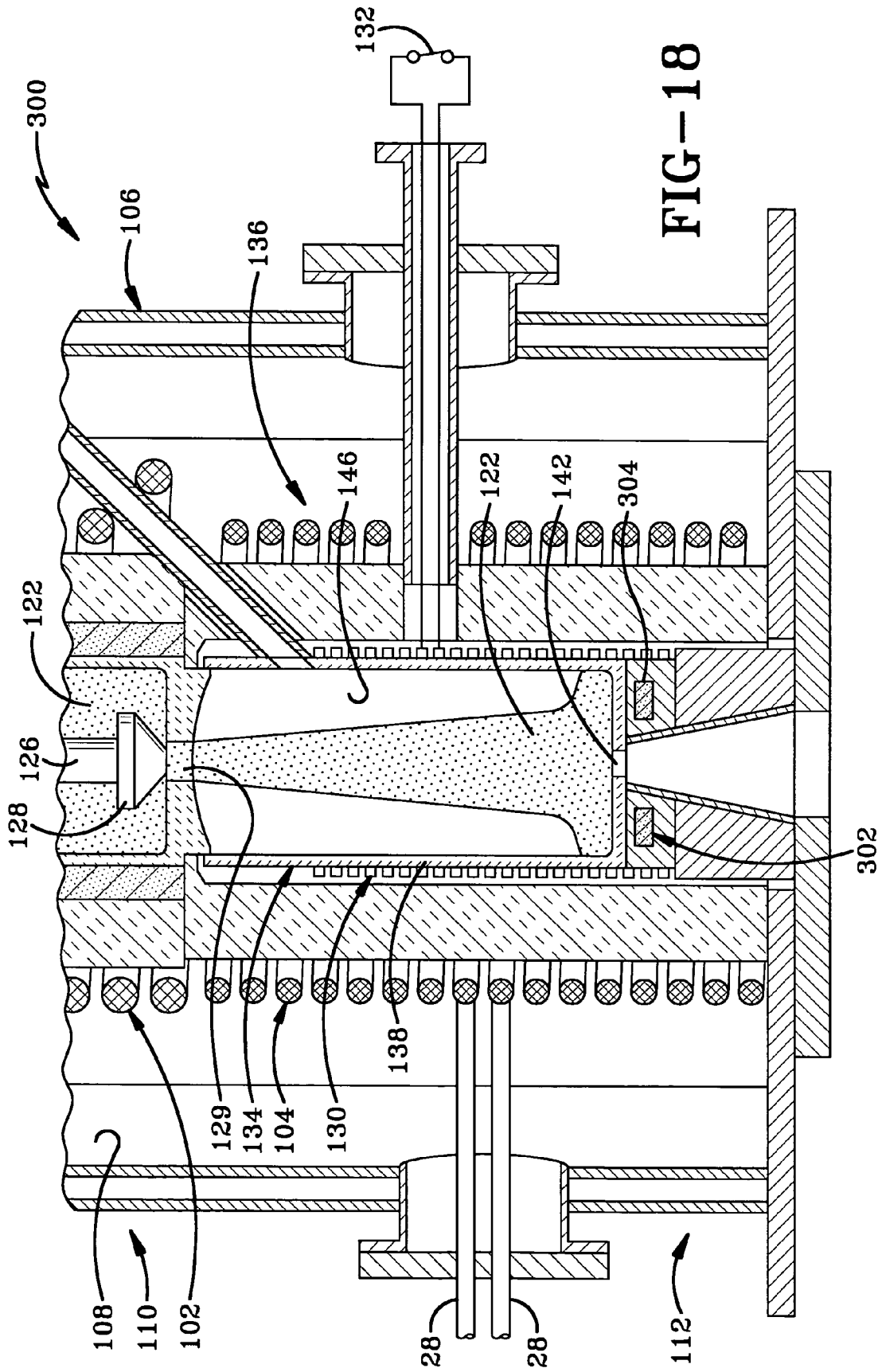
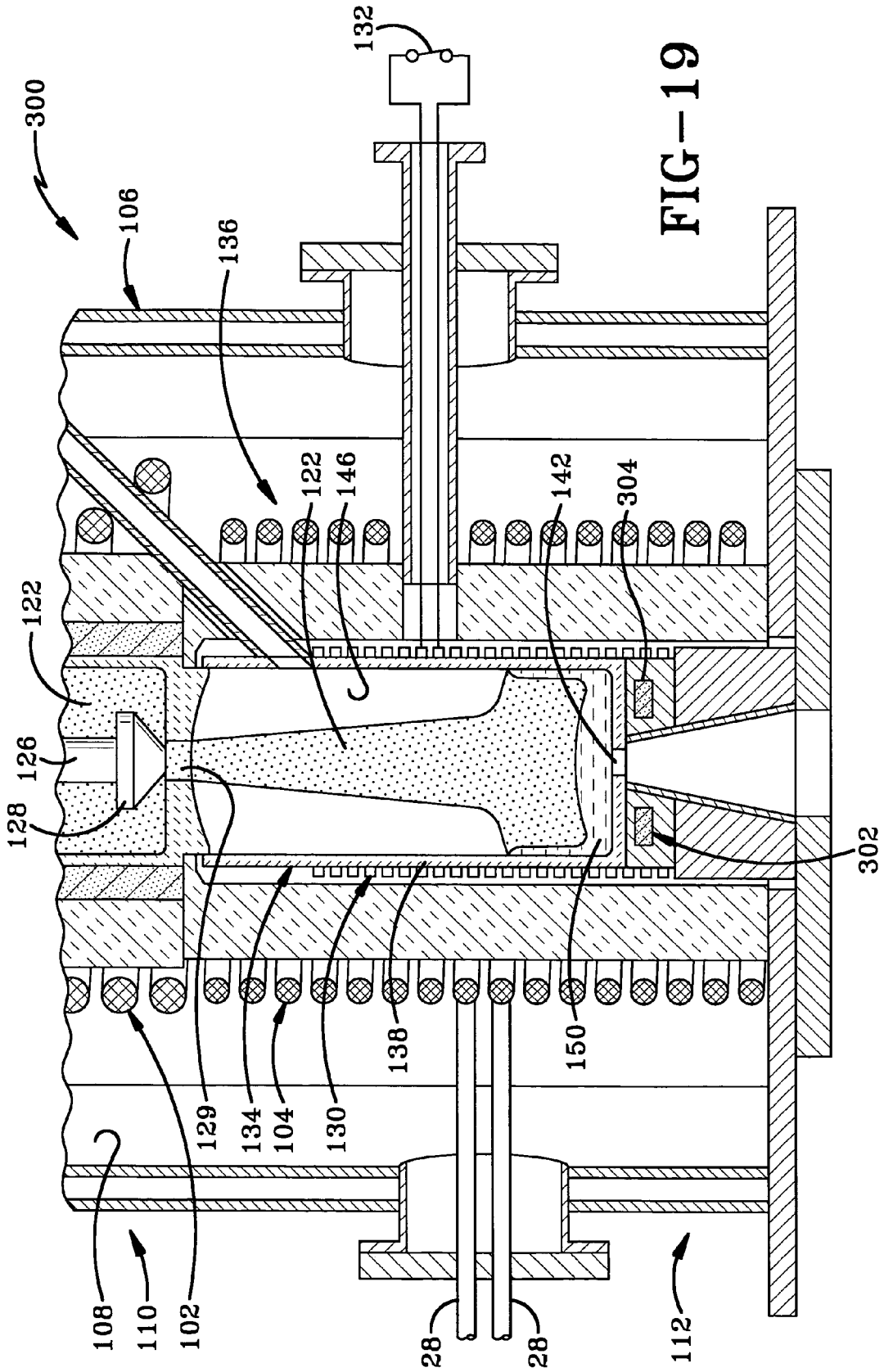
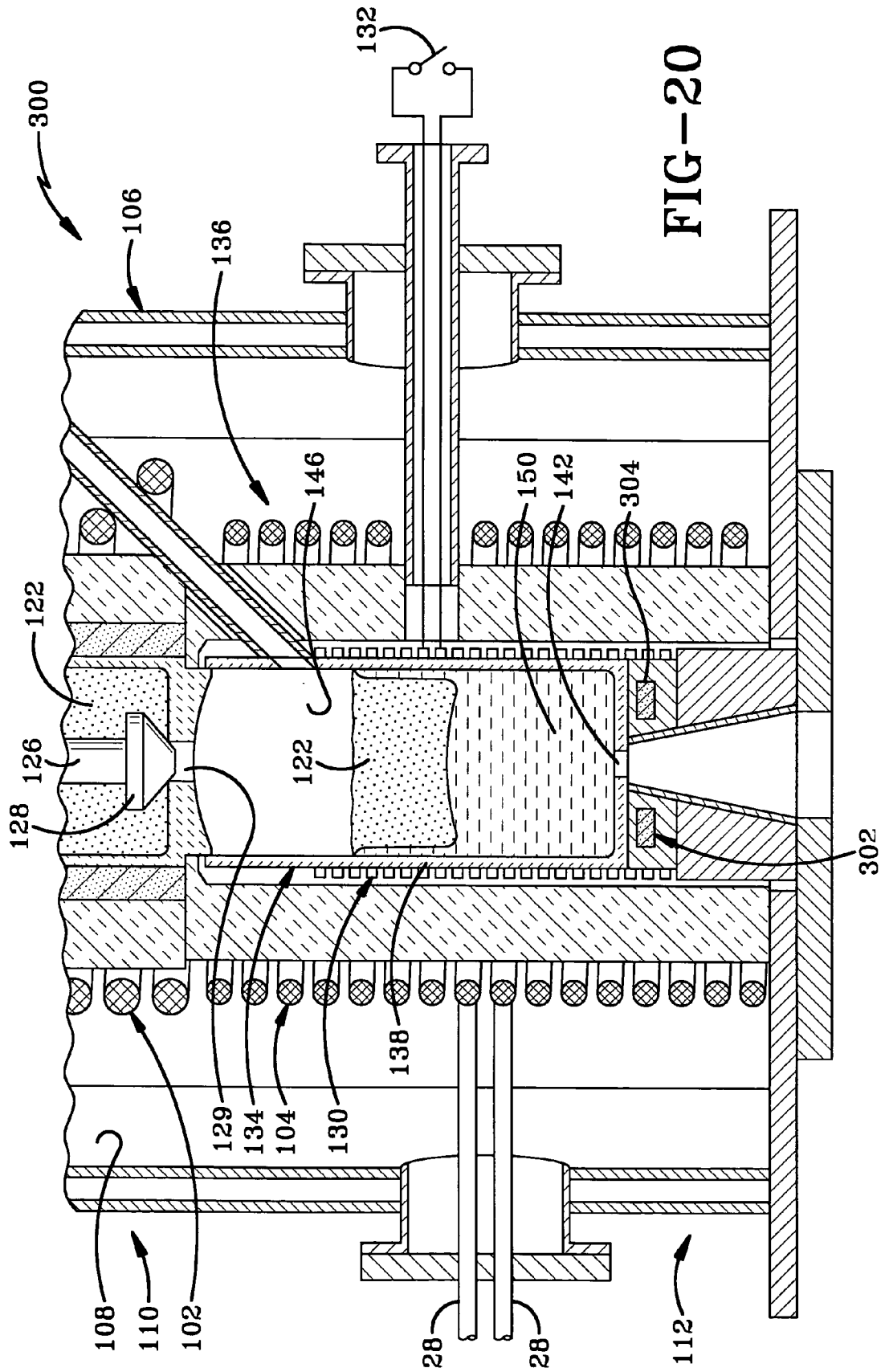

FIG-17







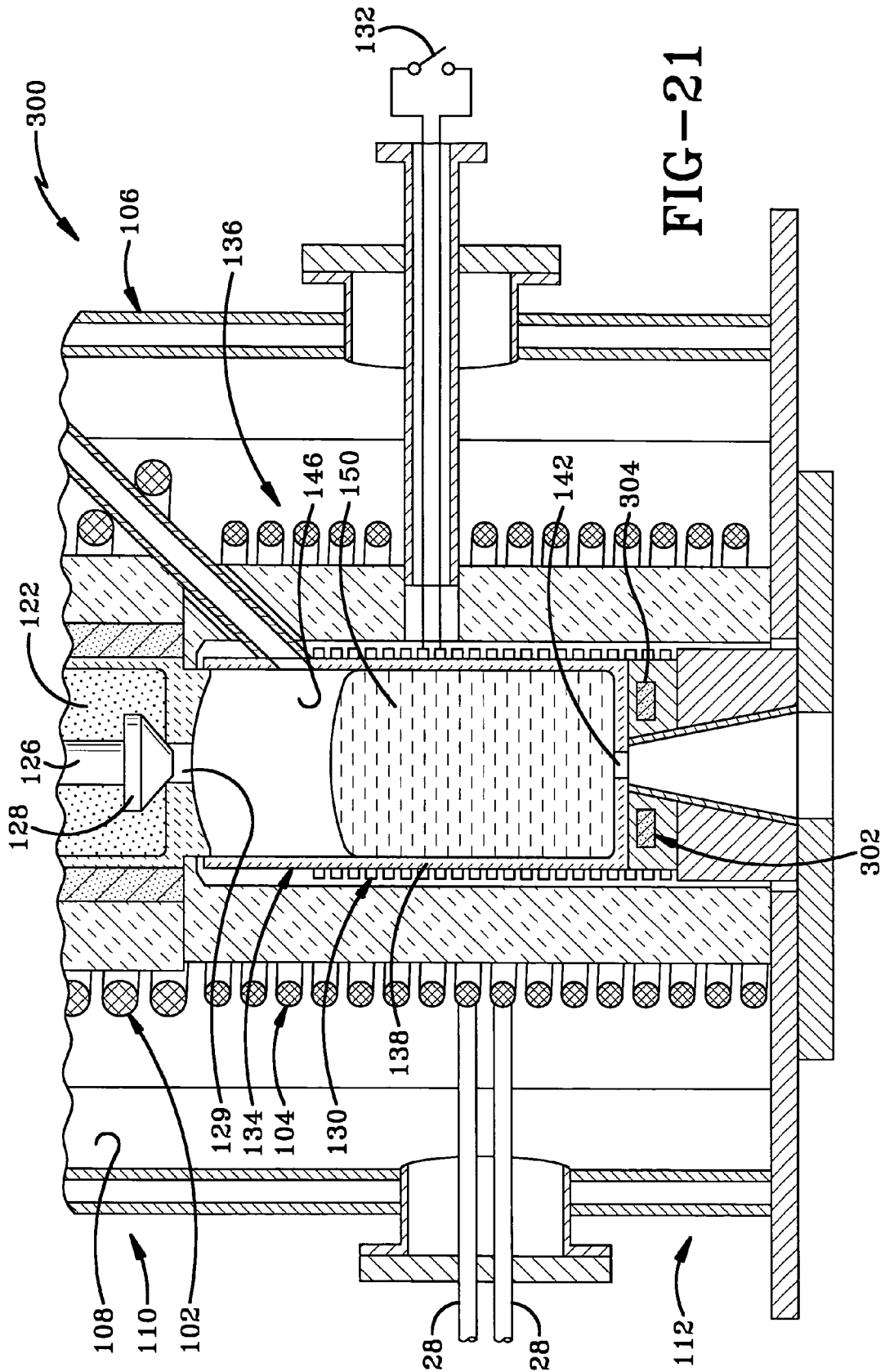

FIG-21

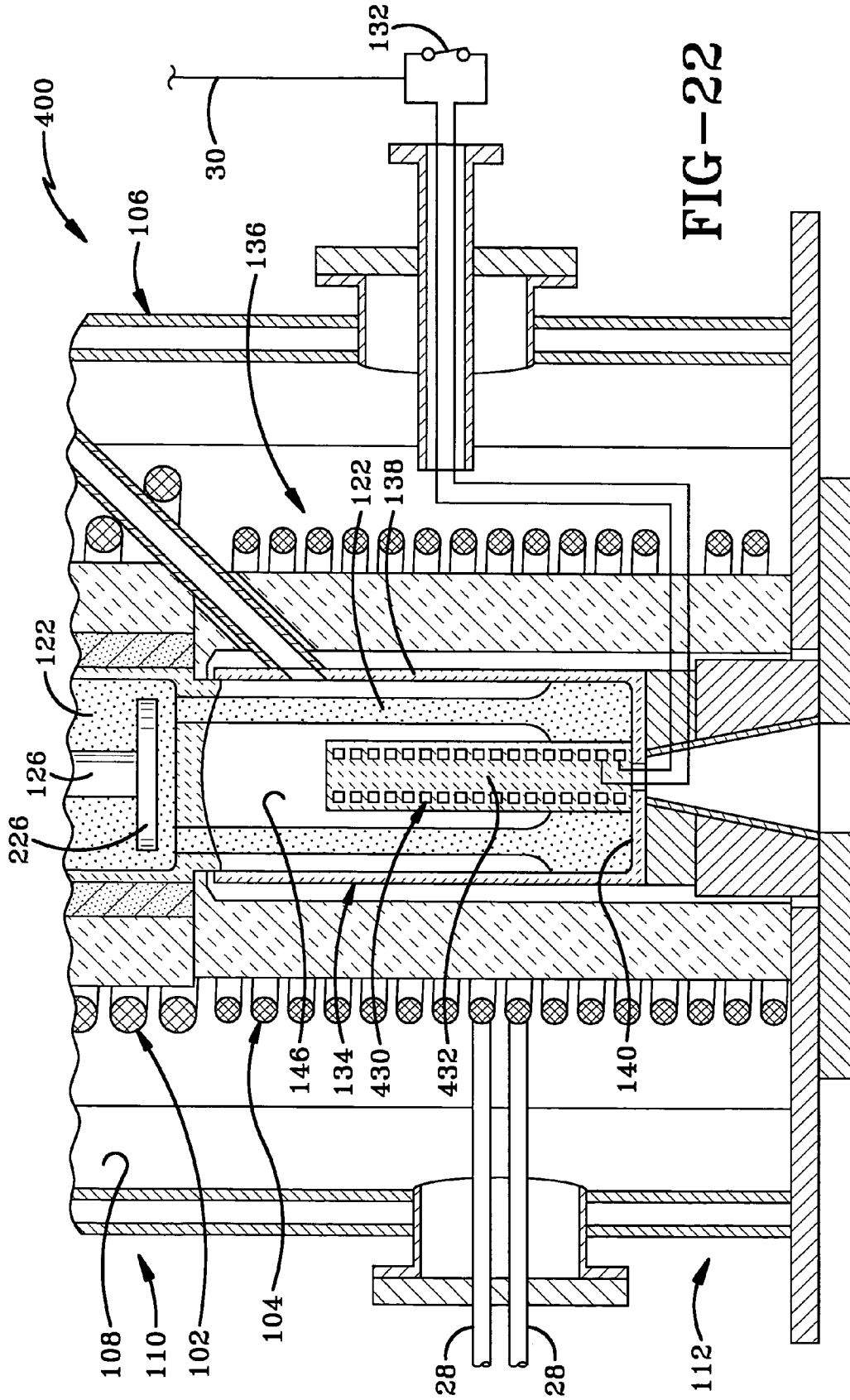

FIG-22

INDUCTION FURNACE FOR MELTING GRANULAR MATERIALS

BACKGROUND OF THE INVENTION

1. Technical Field

The invention relates to induction heating and an improved induction furnace. More particularly, the invention relates to an induction furnace for melting materials not susceptible to inductive heating at lower temperatures but which are susceptible to inductive heating at higher temperatures, especially upon melting. Specifically, the invention relates to an induction furnace capable of continuously or intermittently melting such materials.

2. Background Information

Induction furnaces are well known in the art. However, there are a variety of difficulties related to the inductive heating and melting of materials that are initially non-conductive or which have particle sizes sufficiently small so that they are not susceptible to inductive heating. Many prior art induction furnaces utilize a conductive crucible such that an induction coil couples with the crucible to transfer energy directly to the crucible to heat the crucible whereby heat is then transferred from the crucible to the material to be melted via thermal conduction. In certain cases, the induction frequency and the thickness of the crucible wall may be selected so that a portion of the electromagnetic field from the coil allows coupling with electrically conductive material inside the crucible to inductively heat the material directly. However, the direct inductive heating in such cases is quite limited. Because direct inductive heating of the material to be melted is far more effective than the method described above, a system to effect such direct inductive heating is highly desirable.

In addition, the conductive crucibles of the prior art may react with the material to be melted which causes unwanted impurities in the melt and thus requires the use of a non-reactive liner inside the crucible to prevent formation of such impurities. Typically, however, such liners are electrically non-conductive and thermally insulating. As a result, the transfer of heat from the crucible to the materials to be melted is greatly impeded and thus melting times are substantially increased. To expedite the transfer of heat from the crucible to the material to be melted, the crucible must be heated to undesirably high temperatures which can decrease the life of the crucible and liner.

In addition, there remains a need for an induction furnace capable of producing a continuous melt in an efficient manner, especially for semi-conductor materials. An efficient continuous melt induction furnace is particularly useful related to continuous formation of semi-conductor crystals, which are highly valued in the production of computer chips.

U.S. Pat. No. 6,361,597 to Takase et al. teaches three embodiments of an induction furnace especially intended for melting semi-conductor materials and adapted to supply the molten material to a main crucible for pulling of semi-conductor crystals therefrom. Unlike the prior art discussed above, Takase et al. uses a quartz crucible which is electrically non-conductive along with a susceptor which is in the form of a carbon or graphite cylinder. In each of the three embodiments of Takase et al., the carbon or graphite cylinder susceptor is initially inductively heated by a high frequency coil whereby heat is transferred from the susceptor to raw material inside the crucible in order to begin the melting process. Once the raw material is melted, it is directly inductively heated by the high frequency coil in order to speed up the melting process. While this is a

substantial improvement over the previously discussed prior art, the induction furnace of Takase et al. still leaves room for improvement.

The first two embodiments of Takase et al. involve the use of a carbon cylinder susceptor which encircles the quartz crucible and is movable in a vertical direction. This provides a mechanism whereby the susceptor may be inductively heated and then either moved out of the electromagnetic field of the induction coil altogether or moved to a position which is more advantageous for heating selected portions of the material within the crucible. One drawback of this configuration is the need for a mechanism to move the susceptor in a vertical direction. The third embodiment of Takase et al. provides a susceptor having a crucible-like configuration with a cylindrical side wall of the susceptor covering the side wall of the quartz crucible and a bottom of the susceptor covering the bottom wall of the quartz crucible. The susceptor is not vertically moveable in the third embodiment. Instead, the thickness of the susceptor sidewall and the frequency applied by the coil are selected so that the penetration depth of the induction current will extend beyond the susceptor into the quartz crucible so that it can inductively heat material inside.

The third embodiment of Takase et al. primarily suffers from the fact that the cylindrical susceptor remains in place and thus prevents inductive heating from more effectively being focused on the raw material within the crucible. Instead, the coil continues to inductively heat the carbon cylinder so that energy which might be applied to the material is absorbed by the carbon cylinder, which transfers heat to the raw material in the crucible in a far less effective manner.

BRIEF SUMMARY OF THE INVENTION

The present invention provides an apparatus for heating a material, the apparatus comprising an electromagnetic induction member; an electrically conductive member selectively switchable between a closed electrical circuit and an open electrical circuit whereby the conductive member is inductively heatable by the induction member via the closed electrical circuit and whereby when the conductive member forms the open electrical circuit, inductive heating of the conductive member by the induction member which would occur if the conductive member formed the closed electrical circuit is eliminated; and the conductive member being adapted to transfer heat to the material.

The present invention also provides a method of heating material comprising the steps of: heating an electrically conductive member inductively with an electromagnetic induction member when the conductive member is in a closed electrical circuit mode; transferring heat from the conductive member to the material; and switching the conductive member to an open circuit mode to prevent further inductive heating of the conductive member which would occur if the conductive member remained in the closed circuit mode.

The present invention further provides an apparatus for heating a material, the apparatus comprising an electrically conductive member selectively switchable between a closed electrical circuit mode and an open electrical circuit mode; the conductive member being resistively heatable when in the closed circuit mode and not being resistively heatable when in the open circuit mode; the conductive member being adapted to transfer heat to the material; and an electromagnetic induction member adapted to inductively heat the material.

3

The present invention also provides a method of heating material comprising the steps of heating an electrically conductive member resistively when the conductive member is in a closed electrical circuit mode; transferring heat from the conductive member to the material; heating the material inductively with an electromagnetic induction member; and switching the conductive member to an open circuit mode to prevent inductive heating of the conductive member which would occur if the conductive member remained in the closed circuit mode.

The present invention further provides an apparatus comprising a crucible defining a melting cavity; an electromagnetic induction member for inductively heating molten material within the melting cavity; and a flow guide disposed within the melting cavity for directing the inductively heated molten material to flow upwardly within the cavity.

The present invention also provides an apparatus comprising a crucible defining a melting cavity and an exit opening; and a trap defining a through passage having an entrance end defining an opening in communication with the melting cavity and an exit end defining an opening in communication with the exit opening of the crucible whereby the relative pressure exerted on molten material in the passage controls the flow of molten material through the exit opening.

BRIEF DESCRIPTION OF THE SEVERAL VIEWS OF THE DRAWINGS

Preferred embodiments of the invention, illustrative of the best modes in which applicant contemplates applying the principles, are set forth in the following description and are shown in the drawings and are particularly and distinctly pointed out and set forth in the appended claims.

FIG. 1 is a side elevational view of a first embodiment of the induction furnace of the present invention in use with a preheating assembly and crystal formation apparatus.

FIG. 2 is an enlarged sectional view of the furnace of FIG. 1 showing the first embodiment in use with the preheating assembly.

FIG. 3 is an enlarged fragmentary sectional view of the furnace shown in FIG. 2 showing the crucible empty.

FIG. 4 is similar to FIG. 3 but showing an initial charge of raw material in the crucible.

FIG. 5 is similar to FIG. 4 containing an initial molten portion of the raw material.

FIG. 6 is similar to FIG. 5 showing a further stage of melting.

FIG. 7 is similar to FIG. 6 showing all the material within the crucible in a molten state.

FIG. 8 is a diagrammatic view showing the electromagnetic field acting on the melting coil.

FIG. 9 is similar to FIG. 8 showing the electromagnetic field acting on the molten material within the crucible, and showing electromotive forces acting on the molten material and currents within the molten material.

FIG. 10 is similar to FIG. 2 showing a second embodiment of the induction furnace of the present invention with a generally cone-shaped member within the melting cavity and a trap passage for controlling the flow of molten material from the crucible.

FIG. 11 is an enlarged fragmentary sectional view of the furnace shown in FIG. 10 wherein the crucible is empty.

FIG. 12 is similar to FIG. 11 showing an initial charge of raw material entering the crucible.

4

FIG. 13 is similar to FIG. 12 showing an initial molten portion of the raw material.

FIG. 14 is similar to FIG. 13 showing a further stage of the melting process.

FIG. 15 is similar to FIG. 14 showing all material in the crucible is molten.

FIG. 16 is similar to FIG. 2 showing a third embodiment of the present invention which includes a susceptor disk beneath the crucible.

FIG. 17 is an enlarged fragmentary sectional view of the furnace shown in FIG. 16 wherein the crucible is empty.

FIG. 18 is similar to FIG. 17 showing an initial charge of raw material in the crucible.

FIG. 19 is similar to FIG. 18 showing an initial molten portion of the raw material.

FIG. 20 is similar to FIG. 19 showing a further stage of melting.

FIG. 21 is similar to FIG. 20 showing all of the material in the crucible in a molten state.

FIG. 22 is similar to FIG. 4 showing a fourth embodiment of the induction furnace of the present invention with the melting coil/susceptor disposed within the melting cavity and a feed mechanism like that in FIG. 12.

Similar numbers refer to similar parts throughout the specification.

DETAILED DESCRIPTION OF THE INVENTION

The improved induction furnace of the present invention is shown in four embodiments in the figures although other embodiments are contemplated as is apparent to one of skill in the art. Specifically, the first embodiment of the induction furnace is indicated generally at **100**, and is shown in FIGS. **1-3**, the second embodiment is indicated generally at **200**, and is shown in FIGS. **8-9**, the third embodiment is indicated generally at **300**, and is shown in FIGS. **16-17** and the fourth embodiment is indicated generally at **400**, and is shown in FIG. **22**.

With reference to FIG. 1, furnace **100** is mounted on a support stand **10** via a support arm **12** extending therefrom, although furnace **100** may be supported by any suitable means. Furnace **100** is disposed above and connected to a standard crystal formation apparatus **16** which contains an interior chamber **18** in which is disposed a receiving crucible or tundish **20**. A charge feeder **22** situated above furnace **100** is in communication with a feed port **24** whereby raw material may be fed into furnace **100**. As shown in FIGS. **1-2**, a power supply **26** is in electrical communication via wires **28** with a preheating induction coil **102** and a melting induction coil **104**. Power supply **26** may also be in electrical communication via wires **30** with a melting coil **130**.

With reference to FIG. 2, a double-walled heating container **106** defines an interior chamber **108** which is divided into a preheat zone **110** and a melting zone **112** there below. A preheating assembly **114** is disposed within preheat zone **110** and includes a cylindrical susceptor **116** disposed within preheating induction coil **102** and a preheat tube **118** disposed within susceptor **116** and closely adjacent or in abutment with susceptor **116**. Preheat tube **118** defines an interior chamber **120** for receiving raw material **122** from feed port **24** for preheating the raw material. A feed mechanism **124** includes a control arm **126** with a valve **128** at the terminal end thereof. Valve **128** is selectively seated in exit opening **129** formed in the lower end of preheat tube **118**. Furnace **100** further defines a quiescent zone **131** below preheat assembly **114**, as detailed further below.

In accordance with one of the main features of the present invention and with reference to FIGS. 2-3, substantially cylindrical melting coil 130, which acts as a susceptor, is disposed within melting induction coil 104 and is switchable between a closed electrical circuit mode and an open electrical circuit mode via switch 132. A melting crucible 134 is disposed within melting coil 130 and in combination with melting induction coil 104 and melting coil 130, forms a melting assembly 136. Melting coil 130 may provide lateral support for crucible 134.

Melting crucible 134 includes a substantially cylindrical side wall 138 extending upwardly from a substantially flat bottom wall 140 which defines an exit opening 142 through which the flow of molten material is controlled by any suitable mechanism known in the art. Melting crucible 134 defines a melting cavity 146 in communication with exit opening 142 of bottom wall 140 as well as exit opening 129 of tube 118. In addition, a laser sight port 148 is in visual communication with melting cavity 146.

In operation, and with reference to FIGS. 1-7, furnace 100 functions as follows. Referring to FIGS. 1-3, raw material 122 is fed via charge feeder 22 into feed port 24 and subsequently into interior chamber 120 of preheating tube 118. Valve 128 (an angle of repose valve) is initially in a closed position (FIG. 3) to prevent raw material 122 from passing through exit hole 129. Power supply 26 is then operated to provide electrical power through wires 28 to preheating induction coil 102. Induction coil 102 thus produces an electromagnetic field so that coil 102 couples with susceptor 116 to inductively heat susceptor 116. In turn, susceptor 116 transfers heat to raw material 122 through preheating tube 118 via conduction and radiation. Raw material 122 is thus heated to a point below the melting temperature of the material prior to charging crucible 134. Raw material 122 is typically granular, powdered or of another particulate form. Once material 122 is sufficiently heated, feed mechanism 124 is operated to open valve 128 whereby a portion of material 122 is released into melting cavity 146 of crucible 134, as shown in FIG. 4. Feed mechanism 124 is configured to control the rate at which material 122 falls into melting cavity 146.

In accordance with another feature of the invention and with reference to FIG. 5, power supply 26 provides electrical power to melting induction coil 104 which creates an electromagnetic field so that induction coil 104 couples with melting coil 130 to inductively heat melting coil 130. Inductive heating of melting coil 130 occurs when switch 132 is closed and melting coil 130 thereby forms a closed electrical circuit whereby melting coil 130 is thus initially operated in a closed electrical circuit mode. Once inductively heated, melting coil 130 transfers heat to raw material 122 in melting cavity 146 of crucible 134 predominantly through side wall 138 of crucible 134. As shown in FIG. 5, an initial portion of raw material 122 has melted, the molten portion indicated at 150. During this initial melting process, it has been found that having a portion 152 of melting coil 130 disposed above the charge of material 122 in melting cavity 146 (that is, the material 122 resting within crucible 134 as opposed to the material 122 in a state of falling from preheat tube 118) substantially increases the initial melting rate. This is due to the radiation heat within melting cavity 146 above the charge of material 122 coming from portion 152 of melting coil 130, which compensates for radiation heat loss from said charge of material 122, so that said charge is heated more quickly. Once a sufficient portion of material 122 has been melted by heat transferred from melting coil 130, molten portion 150 becomes susceptible to

inductive heating by induction coil 104. Because melting coil 130 is heating through side wall 138, molten material 150 will include a cylindrical portion which flows down to form a pool portion. The cylindrical portion along side wall 138 provides a greater surface area of susceptible material in comparison to the pool portion, so that direct inductive heating of material 150 is enhanced thereby (FIGS. 5-6).

Another feature of the present invention is heating melting coil 130 resistively, either in combination with the inductive heating or as the sole source of heating melting coil 130. To do this, power supply 26 provides electrical power to melting coil 130 via wires 30 while melting coil 130 forms a closed electrical circuit. Whether used alone or in combination with inductive heating of melting coil 130, the heating of material 122 thereby is continued until a portion of material 122 becomes susceptible to inductive heating.

In accordance with another feature of the present invention, once portion 150 becomes susceptible to inductive heating, switch 132 is opened so that melting coil 130 is in an open electrical circuit mode whereby inductive heating of melting coil 130 by induction coil 104 is predominantly eliminated. More particularly, when melting coil 130 is in the open electrical circuit mode or forms an open electrical circuit, inductive heating of melting coil 130 by induction coil 104 which would occur if melting coil 130 were in the closed electrical circuit mode is eliminated. If melting coil 130 is heated solely by resistance or by resistance in combination with inductive heating by induction coil 104, opening the closed circuit of melting coil 130 also terminates resistive heating. Thus, with melting coil 130 being in an open electrical circuit mode, melting coil 130 has largely "disappeared" to induction coil 104, absorbing very little further energy from the electromagnetic field produced by induction coil 104, as discussed further below. Instead, induction coil 104 couples with the susceptible molten material 150 to directly inductively heat molten portion 150. This direct inductive heating of the susceptible material 150 permits heat to be transferred from molten portion 150 to solid raw material 122 to continue to melt material whereby the additional molten material also becomes susceptible to inductive heating. The "disappearance" of melting coil 130 to inductive heating decreases the heat imparted to crucible 134, which tends to extend the life of crucible 134.

FIG. 5 also shows the continued addition of raw material 122 after melting has begun. Furnace 100 is configured to add raw material 122 as desired. It is often desirable to continuously or intermittently add raw material 122 throughout the melting process to provide continuous or intermittent melting and transfer of molten material 150 out of crucible 134. However, raw material 122 may simply be added in a batch form and melted in its entirety without further additions.

FIG. 6 shows a further stage of melting with switch 132 in the open position whereby melting coil 130 has "disappeared" to coil 104, as noted above. Melting of raw material 122 proceeds via direct inductive heating of molten material 150 until all the material within melting cavity 146 is molten, as shown in FIG. 7. Switch 132 remains in the open position, as the inductive heating of melting coil 130 is not needed or desired after initial molten portion 150 becomes directly heatable by induction. Additional raw material 122 may then be added to the fully molten material, as shown in FIG. 2. Molten material may then be released through exit opening 142 to make room for additional raw material to enter melting cavity 146 so that furnace 100, as noted above, is capable of continuous or intermittent melting. As previ-

ously noted, when induction furnace **100** is used with semiconductor materials, molten semiconductor material may be transferred intermittently or continuously into tundish **120** from which semi-conductor materials may be processed or crystals may be pulled.

Another feature of the invention is quiescent zone **131** (FIG. 2), which is disposed below preheat assembly **114** and provides sufficient space to prevent obstruction of the flow of particulate material **122** from preheat assembly **114** to molten material **150** within melting cavity **146**. Several problems may arise absent quiescent zone **131**, three of which are specified: sticking, premature melting and wicking. Each of these problems relates to the distance between the lower end of preheat assembly **114** (as at exit opening **129** of preheat tube **118**) and a source of heat there below. Typically, the source of this heat is molten material **150** within melting cavity **146** as heated by induction coil **104**. The first two of these problems, sticking and premature melting, are due to overheating of material **122** just prior to exiting from preheat assembly **114** as a result of heat created within melting zone **112** and radiating within melting cavity **146** toward preheat assembly **114**.

Sticking is when material **122** becomes sufficiently hot (at a sub-melting temperature) to cause particles of material **122** to stick to one another and to preheat assembly **114**, thus obstructing the flow of material **122** from preheat assembly **114**. Premature melting is essentially an advanced stage of sticking, whereby material **122** melts prior to exiting preheat assembly **114**. The resultant molten material then sticks to preheat assembly **114** and similarly obstructs the flow of material **122** therefrom whether the material remains molten or freezes on preheat assembly **114**. Thus, sticking and premature melting both involve particles of material **122** sticking to preheat assembly **114**. Premature melting makes correction of the problem more difficult due to molten material ultimately freezing and bonding with greater tenacity to preheat assembly **114** than in the case of “sticking”, wherein the particles do not melt.

The third problem, wicking, relates primarily to the distance between preheat assembly **114** and an upper surface **154** of molten material **150** within melting cavity **146**. Wicking is when a portion of molten material **150** within melting cavity **146** wicks upwardly within interstitial spaces between particles of material **122** via capillary action. When wicking occurs, sufficient heat from said portion of molten material **150** is absorbed by particulate material **122** so that said portion freezes and forms a bridge between molten material **150** in melting cavity **146** and preheat assembly **114**, thus obstructing the flow of material **122** from preheat assembly **114**. Quiescent zone **131** is of sufficient size to prevent obstruction of the flow of material **122** in regard to each of these three problems.

FIG. 8 shows the electromagnetic field produced by induction coil **104** and shows how the electromagnetic field focuses energy on susceptor **116** when switch **132** is closed. While FIG. 8 shows raw material falling into crucible **134**, the same electromagnetic field pattern exists regardless of whether the crucible is filled or unfilled of raw material **122** prior to the time when material **122** becomes susceptible to inductive heating. By contrast, FIG. 9 shows the electromagnetic field after raw material **122** has melted to form molten material **150** and when switch **132** is open, whereby the electromagnetic field focuses energy on molten portion **150** of the material within crucible **134**. Due to the “dis-

largely shifts to the susceptible molten material in crucible **134** when melting coil **130** is in the open circuit mode.

Thus, of the total energy being absorbed by melting coil **130** and the susceptible material within crucible **134**, the vast majority of the energy is being absorbed by melting coil **130** in the closed circuit mode and the vast majority of the energy is being absorbed by the susceptible material when melting coil **130** is in the open circuit mode. Typically, the “vast majority” of the energy being absorbed by melting coil **130** in the closed circuit mode is easily 85 percent or more and often is 90 or 95 percent or more. Similarly, the “vast majority” of the energy being absorbed by the susceptible material when melting coil **130** is in the open circuit mode is easily 85 percent or more and often is 90 or 95 percent or more. Where the melting coil or susceptor is appropriately configured, said percentage of the energy being absorbed by the melting coil in the closed circuit mode may be 99 percent or more and said percentage of the energy being absorbed by the susceptible material when the melting coil is in the open circuit mode may be 99 percent or more.

As is known in the art and with continued reference to FIG. 9, electric current flowing through induction coil **104** creates electromotive forces as indicated by Arrows A, which cause molten material **150** to flow in the direction shown by Arrows B, which show a pattern of current flow known as “quadrature” flow. This current flow within the molten material causes the molten material to have a positive meniscus and creates flow along the surface which aids in drawing raw material **122** into the melt. This is particularly helpful with small-sized particles which otherwise tend to sit atop the molten material due to the surface tension thereof. However, the ability of the quadrature flow to draw raw material **122** into the melt still has limitations and feeding powdered or other particulate material **122** too rapidly into the melting cavity can result in a dome of unmelted material known as a “bridge” sitting atop the molten material. This can cause superheating of the molten bath, leading to excessive refractory wear and potentially to melting of the crucible. As Arrows B in FIG. 9 show, in the upper quadrants, the currents flow upward in the central region and downward in the outer region along side wall **138** of crucible **134**. Currents in the lower quadrants generally flow downwardly in the central region and upwardly in the outer region adjacent side wall **138**, and thus have a pattern which is essentially the opposite of the upper quadrants.

In summary, induction furnace **100** provides a highly efficient means, via the “disappearing” melting coil, of inductively heating semiconductor materials and other materials in particulate form which are not initially susceptible to inductive heating but which become susceptible to inductive heating at higher temperatures or upon melting.

Induction furnace **200** is now described with reference to FIGS. 10–11. Furnace **200** is similar to furnace **100** except that the melting crucible has a different configuration and furnace **200** includes a generally cone-shaped member **214** within the crucible and a trap passage **218**, each of which are described further below. Cone-shaped member **214** alters the flow pattern of currents within molten material in the crucibles. Trap passage **218** serves to control the flow of molten material out of the crucible via pressure differentials on either side of molten material within passage **218**.

Induction furnace **200** includes a crucible **202** having a substantially cylindrical side wall **204** extending upwardly from a bottom wall **206**. Crucible **202** includes a melting cavity **203**, which is in communication with a pressure control source **205** (FIG. 14) for adjusting atmospheric pressure within melting cavity **203**. With reference to FIG.

11, bottom wall 206 includes a generally cone-shaped portion 208 tapering upwardly and inwardly from a substantially flat annular portion 210 to an exit opening 212 formed in cone-shaped portion 208 of bottom wall 206. Exit opening 212 is in communication with a transfer passage 213, which is in communication with a pressure control source 215 (FIG. 14) for adjusting atmospheric pressure within passage 213.

In accordance with another of the main features of the invention and with continued reference to FIGS. 10–11, a flow guide in the form of substantially cone-shaped member 214 is seated within crucible 202 and mounted on bottom wall 206 thereof. Cone-shaped member 214 tapers upwardly and inwardly from adjacent bottom wall 206 and sidewall 204 to an apex 216 (FIG. 11) centrally located within the melting cavity of crucible 202. Cone-shaped member 214 has an outer surface 209 is radially symmetrical about a vertical central axis 211 (FIG. 11). Preferably, cone-shaped member 214 extends to a height above the level to which molten material will rise within melting cavity 203 of crucible 202.

Another feature of the invention (FIG. 11) is a trap 217 which defines a passage 218 formed generally above cone-shaped portion 208 of bottom wall 206 and generally below cone-shaped member 214. Trap passage 218 may be formed between bottom wall 206 and cone-shaped member 214 when member 214 is mounted thereon. Alternately, passage 218 may be formed within bottom wall 208 or within cone-shaped member 214. Trap passage 218 has a lower entrance end 220 defining an opening 227 in communication with melting cavity 203 of crucible 202 and an upper exit end 222 defining an opening 229 in communication with exit opening 212. Passage 218 has a crest 219 and a nadir 221, each extending along the length of passage 218. Crest 219 has a lowermost point 223 at lower entrance end 220. Nadir 221 includes several points, including point 225 at exit end 222, which are higher than lowermost point 223 of crest 219. Lowermost point 223 of crest 221 is at entrance end 220. More broadly, however, the lowermost point of the crest of a trap passage which will function as later described, may be anywhere along the trap passage as long as the nadir of the passage has a point which is higher than the crest lowermost point and which is situated between the crest lowermost point and the exit end of the passage.

However, such a trap passage describes only one category of trap passages. The passage may also, for example, be vertical in its entirety so that no crest or nadir extending along the length of the passage would exist. For such a vertical passage, the exit end opening would be higher than the entrance end opening, and more particularly, the lowermost point of the exit end opening of the passage would be higher than the uppermost point of the entrance end opening. There are further variations, such as certain passages having a portion with vertical walls and another portion which is inclined, which may not fall within either of the two categories noted. Such variations are within the scope of the present invention and can easily be discerned by one skilled in the art.

In addition, with reference to FIG. 10, furnace 200 includes a feed mechanism 224 similar to feed mechanism 124 except for a valve 226 which is distinct from valve 128. Valve 226 is a substantially flat disc shape member. Furnace 200 also includes a preheat tube 228 which is similar to tube 118 of furnace 100, except it finds a plurality of exit openings 230 situated in an annular fashion for aligning raw material 122 to generally fall between cone-shaped members 214 and side wall 204 of crucible 202.

As shown in FIGS. 10–15, furnace 200 functions as follows. Similar to furnace 100, raw material 122 in granular, powdered or other small-particle form, is fed through feed port 24 into the interior chamber of preheat tube 228 and is preheated as previously discussed. The flow of raw material 122 into melting cavity 203 of crucible 202 is controlled by feeding mechanism 224 whereby valve 226 moves in a vertical fashion between an open position to allow material to flow through exit openings 230 and a closed position to close openings 230 to prevent material from flowing.

FIG. 11 shows valve 228 in the closed position to prevent raw material from flowing and crucible 202 prior to being charged with raw material 122. FIG. 12 shows valve 226 of feed mechanism 224 in a raised open position to allow raw material 122 to flow into melting cavity 203 of crucible 202 via exit openings 230. FIG. 13 shows raw material 122 continuing to flow through openings 230 and an initial stage of the melting process caused by electric power from power supply 26 flowing through induction coil 104 to inductively heat melting coil 130 in the closed circuit mode as previously described with regard to furnace 100. As previously described, molten portion 150 within melting cavity 203, has become susceptible to inductive heating by induction coil 104 so that melting coil 130 may be switched to the open circuit mode to prevent further inductive heating of melting coil 130 and to allow inductive heating of molten material 150. FIG. 13 shows some of molten material 150 within trap passage 218.

In accordance with another feature of the invention and with reference to FIGS. 10, 13 and 14, trap 217 is configured so that the portion of molten material 150 in passage 218, forms a liquid seal between entrance end 220 and exit end 222, whereby a pressure differential on the molten material within passage 218 from respective ends 220 and 222 may be controlled to either prevent molten material 150 from flowing into transfer passage 213 (FIG. 14) or allow material 150 to flow out of melting cavity 203 and through exit opening 212 into transfer passage 213 (FIG. 10). When the pressure on the molten material in passage 218 from entrance end 220 is greater than the pressure on the molten material from exit end 222, molten material will flow out of melting cavity 203 through exit opening 212 (FIG. 10). Maintaining an equal pressure on said molten material from entrance end 220 and exit end 222 creates an equilibrium which prevents molten material from flowing out of melting cavity 203 and through exit opening 212 (FIGS. 13–15).

One way of creating a pressure differential to make molten material flow from melting cavity 203 is to add sufficient material, molten and/or raw, to melting cavity 203 to overcome the pressure from exit end 222. As raw material 122 melts, a sufficient amount of molten material 150 will be produced so that it will naturally flow out through exit opening 212 absent other controls. Thus, controlling the pressure of the atmosphere exerted on molten material 150 in passage 218 from entrance end 220 and exit end 222 provides control of the flow of molten material 150. FIG. 14 shows pressure control sources 205 and 215 for controlling this atmospheric pressure. Source 205 may decrease atmospheric pressure from entrance end 220 and/or source 215 may increase atmospheric pressure from exit end 222 to counter the pressure from molten material 150 in melting cavity 203 in order to prevent the flow of molten material through exit opening 212. Alternately, source 205 may increase atmospheric pressure from entrance end 220 and/or source 215 may decrease atmospheric pressure from exit end 222 to allow molten material 150 to flow.

11

The height of the trap passage also controls flow of molten material **150** out of crucible **202**. Increasing the height allows more molten material **150** to collect in the trap passage, and consequently in melting cavity **203**, without the need to use a pressure differential to prevent flow through the exit opening. This basic concept is illustrated in FIG. **13** which shows that insufficient material **122** has been melted to raise the level of molten material **150** within passage **218** above exit opening **212**.

FIG. **14** shows an intermediate stage of melting and FIG. **15** shows all the material within crucible **202** in a molten state. In FIGS. **14** and **15**, valve **226** is in a closed position to prevent further addition of raw material **122**, and switch **132** is in the open position and molten material is being inductively heated directly by induction coil **104**.

In accordance with one another feature of the invention, cone-shaped member **214** has altered the quadrature flow pattern discussed above with reference to FIG. **9** so that the molten material within melting cavity **203** flows as indicated by Arrows C in FIG. **14** and Arrows D in FIG. **15**. In the quadrature pattern of FIG. **9**, current flow in the lower quadrant flows downward in the central region of the melting cavity and upward in the outer region. However, in the present embodiment illustrated in FIGS. **14** and **15**, as material is pushed inwardly due to the electromotive forces, the inward flow within the molten material which would have turned downwardly in the central region of the lower quadrants, is translated by the tapered shape of cone-shaped member **214** and forced upwardly instead. Thus, essentially all of the molten material along the outer surface of cone-shaped member **214** is forced in an upward direction and creates the pattern shown by Arrows C in FIG. **14** and Arrows D in FIG. **15**. The flow is more of a single revolving loop pattern on each side of cone-shaped member **214** as opposed to the pair of loops revolving in opposite directions that occurs within the right or left half of the quadrature pattern of FIG. **9**.

As a result of the molten metal flow created by cone-shaped member **214**, the molten material moves more rapidly overall and creates a higher positive meniscus between cone-shaped member **214** and side wall **204** of crucible **202**. Along with the greater velocity of molten material comes greater turbulence along the surface of the molten material. This increased velocity and turbulence creates an improved ability to draw the small-particle raw material **122** into the molten material to significantly enhance the melting process. As noted, this new current flow provides a higher meniscus and thus increases the surface area of the molten material to provide greater overall contact between the raw material and the molten material. Another benefit of this flow is the production of greater homogeneity of temperature within the molten material. This improved temperature uniformity within the melt translates to a more uniform temperature within the crucible, which is particularly helpful regarding the bottom wall, and thus increases the life of the crucible. Further, to the extent that there is a difference of temperature within the molten material, the hotter portion is at the top of the melt, which improves melting of the solid raw material and also prevents superheating at the bottom of the melt which could lead to melting the crucible.

Once all of the material is molten within melting cavity **203**, it is a relatively simple matter to maintain a continuous or intermittent melting process by simply opening valve **226** to provide additional raw material **122** to melting cavity **203** and allowing molten material to flow through exit opening **212** to provide additional room for new molten material, as shown in FIG. **10**.

12

The third embodiment of the present invention, induction furnace **300**, is now described with reference to FIGS. **16-17**. Furnace **300** is similar to furnace **100** except that furnace **300** includes a disc-shaped susceptor **302** positioned below crucible **134** closely adjacent bottom wall **140** thereof. Preferably, susceptor **302** abuts bottom wall **140**. Susceptor **302** has a substantially cylindrical outer perimeter **304** and an inner perimeter **306** defining a central hole **308**. Susceptor **302**, typically a graphite disc, is not a significant expense.

Another feature of the invention is that outer perimeter **304** of susceptor **302** is further away from induction coil **104** than is an inner surface **312** of crucible side wall **138**. More particularly, susceptor **302** and crucible **134** are configured so that a space **310** within melting cavity **146** is closer to induction coil **104** than is susceptor **302** so that a portion of molten material **150** within space **310** may be closer to coil **104** than is susceptor **302**. Space **310** lies between inner surface **312** of side wall **138** and an imaginary cylinder defined by lines E extending upwardly from outer perimeter **304** of susceptor **302**. Thus, space **310** is disposed within melting cavity **146** all the way around the cylinder defined by lines E and adjacent sidewall **138** along bottom wall **140**.

With reference to FIGS. **17-21**, furnace **300** operates as follows. FIG. **17** shows crucible **134** prior to being charged with raw material **122**. FIG. **18** shows crucible **134** being charged with raw material **122**. At this point or sometime before or shortly afterward, electrical power from power supply **26** produces an electrical current through induction coil **104** and switch **132** is in the closed position whereby susceptor or switchable coil **130** is inductively heated by the electromagnetic field produced by coil **104** as previously described. Once electrical current is flowing through induction coil **104**, it also couples electromagnetically with susceptor **302** to inductively heat susceptor **302** which in turn transfers heat to raw material **122** in order to facilitate melting a portion of material **122**. Thus, melting coil **130** and susceptor **302** are used in conjunction to melt the initial portion **150** of raw material **122**, as shown in FIG. **19**, so that molten portion **150** may then be inductively heated directly by induction coil **104**.

Once portion **150** has become inductively heatable, switch **132** is opened as discussed above, whereby inductive heating of melting coil **130** ceases. Susceptor **302** remains in place and continues to be inductively heated decreasingly as molten material **150** is increasingly inductively heated. Due to the configuration of susceptor **302** described above, the portion of molten material **150** within space **310** is closer to induction coil **104** than is susceptor **302** whereby inductive heating naturally tends towards the molten material because it is closer to induction coil **104**. During the melting process, energy absorbed by molten material **150** from the electromagnetic field produced via induction coil **104** increases and energy absorbed by susceptor **302** from the electromagnetic field decreases. Of the combined energy being absorbed by molten material **150** and susceptor **302**, at a certain time, nearly all of the combined energy is being absorbed by molten material **150** and very little is being absorbed by susceptor **302**. This usually occurs when all the material is fully molten or nearly so in melting cavity **146**. Thus, the configuration of susceptor **302** permits it to nearly "disappear" to the inductive heating effect from induction coil **104**.

FIG. **20** shows an intermediate stage of melting wherein a portion of raw material **122** is molten and a portion is still in solid form. Switch **132** is in the open position so that melting coil **130** is no longer being inductively heated. Susceptor **302** at this point is still being inductively heated

to some degree although this is decreasing as previously noted. By the time all the material within crucible **134** is molten, as shown in FIG. **21**, essentially all the inductive heating taking place is occurring directly within molten material **150** while a relatively small amount is occurring within susceptor **302**. Hole **308** in susceptor **302** allows for a central pouring mechanism so that molten material may flow through hole **308**. Additional material **122** may be added via exit opening **129** and molten material may be removed through exit opening **142**, as shown in FIG. **16**, so that furnace **300** is capable of continuous and intermittent melting.

The fourth embodiment of the present invention, induction furnace **400**, is now described with reference to FIG. **22**. Furnace **400** is similar to furnace **100** except that furnace **400** includes a melting coil **430**, which acts as a susceptor and is disposed within melting cavity **146** of crucible **134** instead of outside crucible **134**. Because melting coil **430** is situated centrally within melting cavity **146**, a feed mechanism like feed mechanism **224** used with the furnace **200** is utilized. The location of melting coil **430** within crucible **134** may vary, however, and thus other feed mechanisms may be more suitable depending on said location and the specific configuration of such an internal susceptor. Melting coil **430** is encased within a refractory material **432** such as ceramic, although this may vary in accordance with the material to be melted or heated. The basic concept of melting coil **430** is the same as that of melting coil **130** other than its location. More specifically, melting coil **430** may be switched between an open circuit mode and a closed circuit mode via switch **132** and is thus heatable as described with respect to furnace **100**. The melting pattern which occurs with the use of melting coil **430** differs in that material **122** begins to melt adjacent melting coil **430** instead of adjacent sidewall **138**. In addition, once material **122** becomes susceptible to inductive heating, induction coil **104** will tend to couple with material **122** in preference to coupling with melting coil **430** even when the circuit is closed because some susceptible material is closer to induction coil **104** than is melting coil **430**, as explained with regard to susceptor **302** of furnace **300**. Opening the circuit of melting coil **430**, however, further removes melting coil **430** from being inductively heated, as with the other "disappearing" coils.

Thus, induction furnaces **100**, **200**, **300** and **400** provide novel configurations and methods of inductively heating and melting particulate material which is initially not inductively heatable and which becomes inductively heatable when heated to a certain temperature and especially upon melting. It will be appreciated that a great number of changes may be made to each of these furnaces without departing from the spirit of the invention. It will be appreciated that each of these furnaces may function without the preheating assembly although this facilitates the melting process. In addition, the preheating assembly may be of other suitable configurations which do not use inductive heating.

Furnaces **100**, **200**, **300** and **400** utilize the "disappearing" melting coil **130** or **430** particularly for melting such materials as described herein. However, the concept of the disappearing coil may be utilized in a wide variety of circumstances. It need not be used for melting purposes, but may be used simply to inductively heat something in a selective fashion whereby the switch may be turned on and off as desired. In addition, melting coil **130** or **430** need not be in a coil form but merely needs to form a closed circuit when a switch is closed and an open circuit when the switch is open whereby it can be inductively heated when the switch is closed. Further, melting coil **130** or **430** need not

be disposed within an induction coil which is in the form of a cylinder or other shape. Instead, melting coil **130** or **430** may be positioned externally near an induction coil so that it is within the electromagnetic field produced thereby. At a broader level, the electromagnetic field which inductively heats melting coil **130** or **430** need not be produced by an induction coil but by any induction member through which an electrical current may be passed to create an electromagnetic field capable of inductively heating melting coil **130** or **430** or a similar disappearing coil. For the purposes of an induction furnace for melting highly refractory materials, the exemplary embodiments are preferred due to their levels of efficiency.

Further, the use of the disappearing coil is not limited to melting or heating only particulate material. It may also be used to melt or heat larger pieces of material. Thus, for example, the disappearing coil may be effectively used with larger pieces of materials which, like semi-conductor materials, are not inductively heatable in solid form regardless of size. In addition, the present invention may also be used with fibrous materials or other materials having geometries which are particularly difficult to melt via inductive heating.

Certain liquids are also particularly suited to heating with the present invention, for example, those liquids which are not susceptible to inductive heating at a relatively lower temperature but which are susceptible to inductive heating at relatively higher temperature. The invention is also suitable for heating liquids which are susceptible to inductive heating at relatively higher frequencies (i.e., higher frequency electrical current to the induction coil) at a relatively lower temperature and which are susceptible to inductive heating at relatively lower frequencies at a relatively higher temperature due to the corresponding lowered resistivity of the liquid at the higher temperature. This may include scenarios wherein such liquids are simply not inductively heatable at the relatively lower frequency when the liquid is at the relatively lower temperature. This may also include scenarios wherein such liquids are susceptible to inductive heating to some degree at the lower frequency and lower temperature, but only at a relatively lower efficiency, while this efficiency increases at the lower frequency when the temperature of the liquid is sufficiently raised. Thus, the invention is particularly useful in that the disappearing coil can heat such liquids to bring them into a temperature range where commercially feasible lower frequencies can be used to inductively heat the liquids, substantially increasing the efficiency of heating such liquids.

The flow guide, embodied as a cone-shaped member in induction furnace **200**, may also take a variety of shapes, although a general cone shape is preferred, particularly with a cylindrical crucible and cylindrical induction coil. Other shapes which alter the flow of the molten material so that currents in the central or interior regions of a crucible melting cavity tend to flow upwardly rather than downwardly are within the scope of the concept of the present invention. As noted previously, such a change in the current flow within the molten material prevents overheating of the crucible bottom wall, provides greater uniformity of temperature within the melt and adds to the ability to draw raw material into the melt. Some of the obvious alternatives include a cone shape that has a convex or a concave outer surface. Also pyramidal shapes may be used or cone shapes that may have ridges and recesses such as a star-shaped cone-like structure. Other possibilities include a tent-shaped member having elongated sides which taper upwardly and inwardly or an elongated mound shape having a parabolic or semicircular cross section. In addition, while the outer

15

surface of the member in issue is preferably continuous, it may also be noncontinuous and may be created by a plurality of members in combination. A host of other configurations is within the scope of the present invention.

With regard to the trap passage of induction furnace **200**, many configurations are also possible, as previously described. With regard to the forming use of the cone-shaped member, a trap passage may be created by, for example, forming slots or other openings in the lower portion of the cone-shaped member. Further, such passages do not require the use of a cone-shaped member or the like. Consequently, the crucible bottom wall need not be generally cone-shaped, but may, for example, be substantially flat with a tube extending upwardly into the melting cavity to provide a raised exit opening in communication with an upper portion of the trap passage. The trap passage may also be disposed outside of the crucible, such as may be defined by a pipe extending outwardly from the crucible side wall.

Also with regard to induction furnace **200**, the valve used in the preheating assembly may be used without a preheating assembly and may be of a variety of configurations. While it is preferable to guide the raw material directly onto the upper surface of the molten material, the raw material may also fall on to the cone-shaped member and so forth.

With respect to induction furnace **300**, susceptor **302** need not be disc-shaped or have a hole formed therein. Susceptor **302** may have a variety of shapes as long as some space within the crucible melting cavity for holding a molten portion is closer to the induction coil than is the susceptor itself, whereby the susceptible molten material is preferentially inductively heated with respect to a susceptor analogous to susceptor **302**. While susceptor **302** is typically made of graphite, it may be formed of any material capable of being inductively heated.

In the foregoing description, certain terms have been used for brevity, clearness, and understanding. No unnecessary limitations are to be implied therefrom beyond the requirement of the prior art because such terms are used for descriptive purposes and are intended to be broadly construed.

Moreover, the description and illustration of the invention is an example and the invention is not limited to the exact details shown or described.

The invention claimed is:

1. An apparatus for heating a material, the apparatus comprising:

an electromagnetic induction coil an interior space;

an electrically conductive member comprising an electrical circuit selectively switchable between a closed electrical circuit mode and an open electrical circuit mode;

wherein a portion of the conductive member is disposed within the induction coil interior space whereby the conductive member is inductively heatable by the induction coil via the electrical circuit in the closed electrical circuit mode;

wherein the induction coil is capable of being electrically powered when the conductive member is in the closed circuit mode and when the conductive member is in the open circuit mode; and

the conductive member being adapted to transfer heat to the material.

2. A method of heating a material comprising the steps of: placing the material in a melting cavity of an electrically non-conductive crucible;

16

positioning an electrically conductive susceptor adjacent the crucible so that a portion of the melting cavity is closer to the induction member than is the susceptor; heating an electrically conductive member inductively with an electromagnetic induction member when the conductive member is in a closed electrical circuit mode;

transferring heat from the conductive member to the material;

switching the conductive member to an open circuit mode to prevent further inductive heating of the conductive member which would occur if the conductive member remained in the closed circuit mode;

heating the susceptor inductively with the induction member; and

transferring heat from the susceptor to the material in the melting cavity.

3. An apparatus for heating a material, the apparatus comprising:

an electromagnetic induction coil having an interior space;

an electrically conductive member comprising an electrical circuit selectively switchable between a closed electrical circuit mode and an open electrical circuit mode;

wherein a portion of the conductive member is disposed within the induction coil interior space;

wherein the conductive member is inductively heatable by the induction coil via the electrical circuit in the closed electrical circuit mode;

wherein the conductive member in the open circuit mode prevents inductive heating of the conductive member which would occur if the conductive member were in the closed circuit mode;

the conductive member being adapted to transfer heat to the material; and

an electrically non-conductive crucible defining a melting cavity adapted to contain the material; wherein the conductive member includes a coil defining an interior space; and in which a portion of the crucible is disposed within the interior space of the conductive member coil.

4. The apparatus of claim **3** wherein continuous and intermittent melting capability is provided by a feed mechanism for adding portions of the material to the melting cavity; and in which a transfer mechanism transfers molten material from the melting cavity.

5. The apparatus of claim **4** wherein the material is a semi-conductor material; in which a receiving crucible receives said semi-conductor material in molten form from the non-conductive crucible and is adapted to form a semi-conductor crystal from the material in the receiving crucible, whereby the apparatus is capable of continuously and intermittently providing molten semi-conductor material to the receiving crucible.

6. The apparatus of claim **1** further including an electrically non-conductive crucible defining a melting cavity adapted to contain the material; and wherein the conductive member is disposed within the melting cavity.

7. The apparatus of claim **1** further including an electrically non-conductive crucible defining a melting cavity adapted to contain the material; and wherein a portion of the conductive member is disposed higher than the material in the melting cavity whereby said portion transfers heat via radiation into the melting cavity above the material.

8. An apparatus for heating a material, the apparatus comprising:

17

an electromagnetic induction member;
 an electrically conductive member comprising an electrical circuit selectively switchable between a closed electrical circuit mode and an open electrical circuit mode;
 wherein the conductive member is inductively heatable by the induction member via the electrical circuit in the closed electrical circuit mode;
 wherein the conductive member in the open circuit mode prevents inductive heating of the conductive member which would occur if the conductive member were in the closed circuit mode;
 the conductive member being adapted to transfer heat to the material; and
 an electrically non-conductive crucible defining a melting cavity and an electrically-conductive susceptor disposed adjacent the crucible; wherein the induction member is capable of inductively heating material within the melting cavity and the susceptor; and wherein a portion of the melting cavity is closer to the induction member than is the susceptor.

9. An apparatus for heating a material, the apparatus comprising:
 an electromagnetic induction member;
 an electrically conductive member comprising an electrical circuit selectively switchable between a closed electrical circuit mode and an open electrical circuit mode;
 wherein the conductive member is inductively heatable by the induction member via the electrical circuit in the closed electrical circuit mode;
 wherein the conductive member in the open circuit mode prevents inductive heating of the conductive member which would occur if the conductive member were in the closed circuit mode;
 the conductive member being adapted to transfer heat to the material; and
 an electrically non-conductive crucible defining a melting cavity adapted to contain the material and a preheat assembly for heating the material prior to entering the melting cavity; and wherein the preheat assembly bounds a quiescent zone there below through which the material falls when feeding the melting cavity; the quiescent zone being suitably sized to prevent obstruction of the flow of the material from the preheat assembly due to overheating and consequent sticking of the material to the preheat assembly or due to formation of a bridge between molten material in the melting cavity and the preheat assembly via wicking of the molten material.

10. The apparatus of claim 1 wherein the conductive member is resistively heatable in the closed circuit mode and not resistively heatable in the open circuit mode.

11. The apparatus of claim 3 further including a generally cone-shaped member which tapers upwardly and inwardly within the melting cavity for guiding molten material flow created by electromotive forces emanating from the induction member.

12. The apparatus of claim 3 wherein the crucible has an exit opening; and further including a trap defining a through passage having an entrance end defining an opening in communication with the melting cavity and an exit end defining an opening in communication with the exit opening of the crucible for transporting molten material from the melting cavity to the exit opening of the crucible whereby a

18

relative pressure exerted on molten material in the passage controls the flow of molten material through the exit opening.

13. The apparatus of claim 1 wherein an electrically non-conductive crucible defines a melting cavity containing the material, a portion of which is susceptible to inductive heating; wherein an electrical current passes through the induction member to produce an electromagnetic field; wherein the conductive member and the susceptible portion of the material absorb energy from the electromagnetic field; and wherein, of the total energy absorbed from the electromagnetic field by the conductive member and by the susceptible portion when the conductive member is switched to the open electrical circuit mode, at least 85 percent is absorbed by the susceptible portion.

14. The apparatus of claim 1 wherein an electrically non-conductive crucible defines a melting cavity containing the material, a portion of which is susceptible to inductive heating; wherein an electrical current passes through the induction member to produce an electromagnetic field; wherein the conductive member and the susceptible portion of the material absorb energy from the electromagnetic field; and wherein, of the total energy absorbed from the electromagnetic field by the conductive member and by the susceptible portion when the conductive member is switched to the open electrical circuit mode, at least 95 percent is absorbed by the susceptible portion.

15. A method of heating a material comprising the steps of:

heating an electrically conductive member inductively with an electromagnetic induction member when the conductive member is in a closed electrical circuit mode; a portion of the conductive member being disposed within an interior space of the induction member; transferring heat from the conductive member to the material; and
 switching the conductive member to an open circuit mode to prevent further inductive heating of the conductive member which would occur if the conductive member remained in the closed circuit mode; and
 heating the material inductively with the induction member while the conductive member is in the open circuit mode.

16. The method of claim 2 further including the step of heating the material inductively with the induction member.

17. The method of claim 15 further including the steps of placing the material in an electrically non-conductive crucible melting cavity; positioning a portion of the conductive member higher than an upper surface of the material; and transferring heat from the portion of the conductive member by radiation into the melting cavity above the material.

18. The method of claim 15 wherein the transferring step includes the step of heating the material sufficiently to make a portion of the material susceptible to inductive heating.

19. The method of claim 18 further including the steps of placing the material in an electrically non-conductive crucible melting cavity and heating the susceptible portion inductively with the induction member to melt solid portions of the material.

20. The method of claim 19 further including the steps of adding additional solid portions of the material via a feed mechanism to the melting cavity and melting the additional solid portions within the melting cavity by heating the susceptible portion inductively with the induction member.

21. A method of heating a material comprising the steps of:

19

placing the material in an electrically non-conductive crucible melting cavity;
 heating an electrically conductive member inductively with an electromagnetic induction member when the conductive member is in a closed electrical circuit mode;
 transferring sufficient heat from the conductive member to the material to make a portion of the material susceptible to inductive heating;
 switching the conductive member to an open circuit mode to prevent further inductive heating of the conductive member which would occur if the conductive member remained in the closed circuit mode;
 heating the susceptible portion inductively with the induction member to melt solid portions of the material;
 adding additional solid portions of the material in particulate form via a feed mechanism to the melting cavity; wherein the adding step includes allowing particles of the material to fall through a quiescent zone to prevent obstruction of the flow of the material from a preheat assembly due to overheating and consequent sticking of the particles to the feed mechanism or due to formation of a bridge between molten material in the melting cavity and the feed mechanism via wicking of the molten material; and
 melting the additional solid portions within the melting cavity by heating the susceptible portion inductively with the induction member.

22. The method of claim 20 further including the step of transferring molten material from the non-conductive crucible into a receiving crucible.

23. The method of claim 22 wherein the material is a semi-conductor material and the method further includes the step of forming a semi-conductor crystal from the molten material in the receiving crucible.

24. The method of claim 23 further including the step of continuously or intermittently providing molten material from the non-conductive crucible to the receiving crucible.

25. A method of heating a material comprising the steps of:

placing the material in an electrically non-conductive crucible melting cavity;
 heating an electrically conductive member inductively with an electromagnetic induction member when the conductive member is in a closed electrical circuit mode;
 transferring sufficient heat from the conductive member to the material to make a portion of the material susceptible to inductive heating;
 heating the susceptible portion inductively with the induction member to melt solid portions of the material;
 switching the conductive member to an open circuit mode to prevent further inductive heating of the conductive member which would occur if the conductive member remained in the closed circuit mode; and
 guiding the flow of molten material within the melting cavity with an inwardly and upwardly tapering generally cone-shaped member disposed in the melting cavity.

26. A method of heating a material comprising the steps of:

placing the material in an electrically non-conductive crucible melting cavity;
 heating an electrically conductive member inductively with an electromagnetic induction member when the conductive member is in a closed electrical circuit mode;

20

transferring sufficient heat from the conductive member to the material to make a portion of the material susceptible to inductive heating;
 heating the susceptible portion inductively with the induction member to melt solid portions of the material;
 switching the conductive member to an open circuit mode to prevent further inductive heating of the conductive member which would occur if the conductive member remained in the closed circuit mode; and
 controlling a relative pressure exerted on molten material in a trap passage from an entrance end of the trap passage in communication with the melting cavity and from an exit end of the trap passage in communication with an exit opening formed in the crucible to selectively allow and prevent the flow of molten material from the melting cavity through the exit opening.

27. The apparatus of claim 1 wherein the induction coil forms part of an electrical circuit which is different from the electrical circuit of the conductive member.

28. The method of claim 15 further including the step of heating the conductive member resistively when the conductive member forms the closed electrical circuit mode.

29. The apparatus of claim 1 in combination with an electrical power source in electrical communication with the induction coil for powering the induction coil when the conductive member is in the closed circuit mode and when the conductive member is in the open circuit mode.

30. The apparatus of claim 1 further including an electrically non-conductive crucible defining a melting cavity adapted to contain the material; and wherein the crucible has a stationary bottom wall which bounds the melting cavity.

31. The apparatus of claim 30 wherein the bottom wall of the crucible is disposed within the induction coil interior space.

32. The apparatus of claim 1 further including an electrically non-conductive crucible defining a melting cavity adapted to contain the material; wherein the conductive member includes a coil defining an interior space; and wherein a portion of the crucible is disposed within the interior space of the conductive member coil.

33. The apparatus of claim 1 further including a crucible defining a melting cavity adapted to contain molten material; wherein the induction member is configured to inductively heat molten material within the melting cavity; and wherein a flow guide is disposed within the melting cavity for directing the inductively heated molten material to flow upwardly within the cavity.

34. The apparatus of claim 33 wherein the flow guide tapers upwardly and inwardly with regard to a bottom wall of the crucible.

35. The apparatus of claim 34 wherein the flow guide has an outer surface which is substantially radially symmetrical with respect to a vertical axis.

36. The apparatus of claim 3 wherein the conductive member coil is at least partially disposed in the induction coil interior space.

37. The apparatus of claim 36 wherein the conductive member coil is entirely disposed in the induction coil interior space.

38. The apparatus of claim 6 wherein the conductive member is encased in a refractory material adapted to prevent contact between the conductive member and molten material within the melting cavity.

39. The apparatus of claim 12 wherein the passage has a crest and a nadir each extending along the length of the passage; the crest having a lowermost point and the nadir

21

having a point between the lowermost point of the crest and the exit end of the trap passage which is higher than the lowermost point of the crest.

40. The apparatus of claim 12 wherein the exit end is higher than the entrance end.

41. The apparatus of claim 12 further including at least one of a pressure control source for controlling atmospheric pressure exerted on the molten material from the entrance end of the passage and a pressure control source for controlling atmospheric pressure exerted on the molten material from the exit end of the passage.

42. The method of claim 15 further including the steps of melting the material within a melting cavity of a crucible; inductively heating molten material within the melting cavity to create flow of molten material due to electromotive forces emanating from the induction member; and guiding molten material flow upwardly within the melting cavity with a flow guide disposed therein.

22

43. The method of claim 42 wherein step of guiding includes the step of guiding molten material flow upwardly within the melting cavity with a flow guide which tapers upwardly and inwardly.

44. The apparatus of claim 3 wherein the induction coil is capable of being electrically powered when the conductive member is in the closed circuit mode and when the conductive member is in the open circuit mode.

45. The apparatus of claim 8 wherein the induction coil is capable of being electrically powered when the conductive member is in the closed circuit mode and when the conductive member is in the open circuit mode.

46. The apparatus of claim 9 wherein the induction coil is capable of being electrically powered when the conductive member is in the closed circuit mode and when the conductive member is in the open circuit mode.

* * * * *