

[54] **HYDRAULIC SYSTEM FOR WHEELED STRETCHERS**

2,837,380 6/1958 Mazzarins 305/10
 3,393,004 7/1968 Williams 296/20
 3,572,746 3/1971 Mueller 280/6 H

[75] Inventor: **Paul D. Limpach**, Napoleon, Ohio

[73] Assignee: **Gendron-Diemer, Inc.**, Archbold, Ohio

[22] Filed: **Oct. 6, 1972**

[21] Appl. No.: **295,682**

Primary Examiner—Philip Goodman
Assistant Examiner—John A. Carroll
Attorney, Agent, or Firm—Wilson & Fraser

[52] U.S. Cl. **296/20**

[51] Int. Cl. **B62b 3/02**

[58] Field of Search 296/20; 280/6 H; 305/10

[57] **ABSTRACT**

A hydraulically actuated wheeled stretcher wherein the patient supporting surface may be rapidly raised, tilted or lowered. The lowering operation is assisted by gas pressure from an accumulator into the upper portion of the lift cylinders.

[56] **References Cited**

UNITED STATES PATENTS

2,837,379 6/1958 Selyem et al. 305/10

8 Claims, 7 Drawing Figures

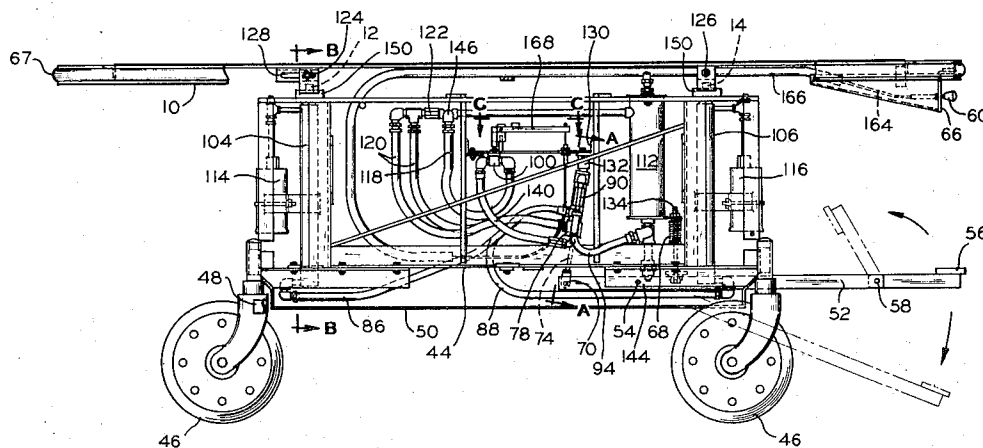

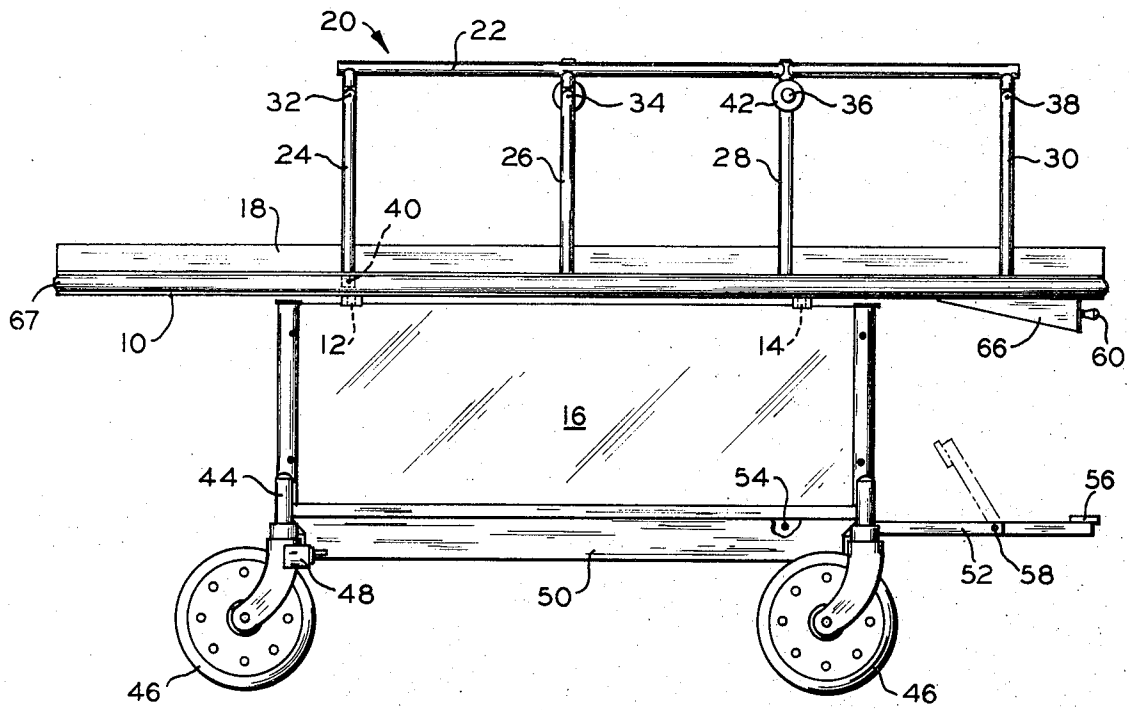

FIG. 1

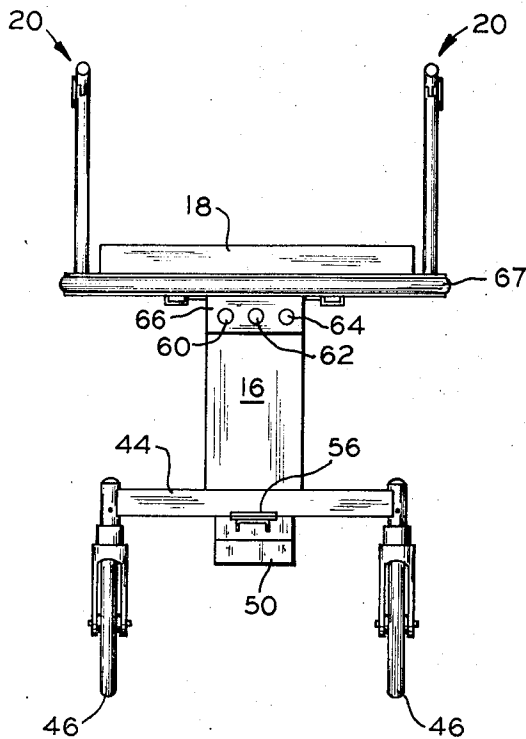

FIG. 2

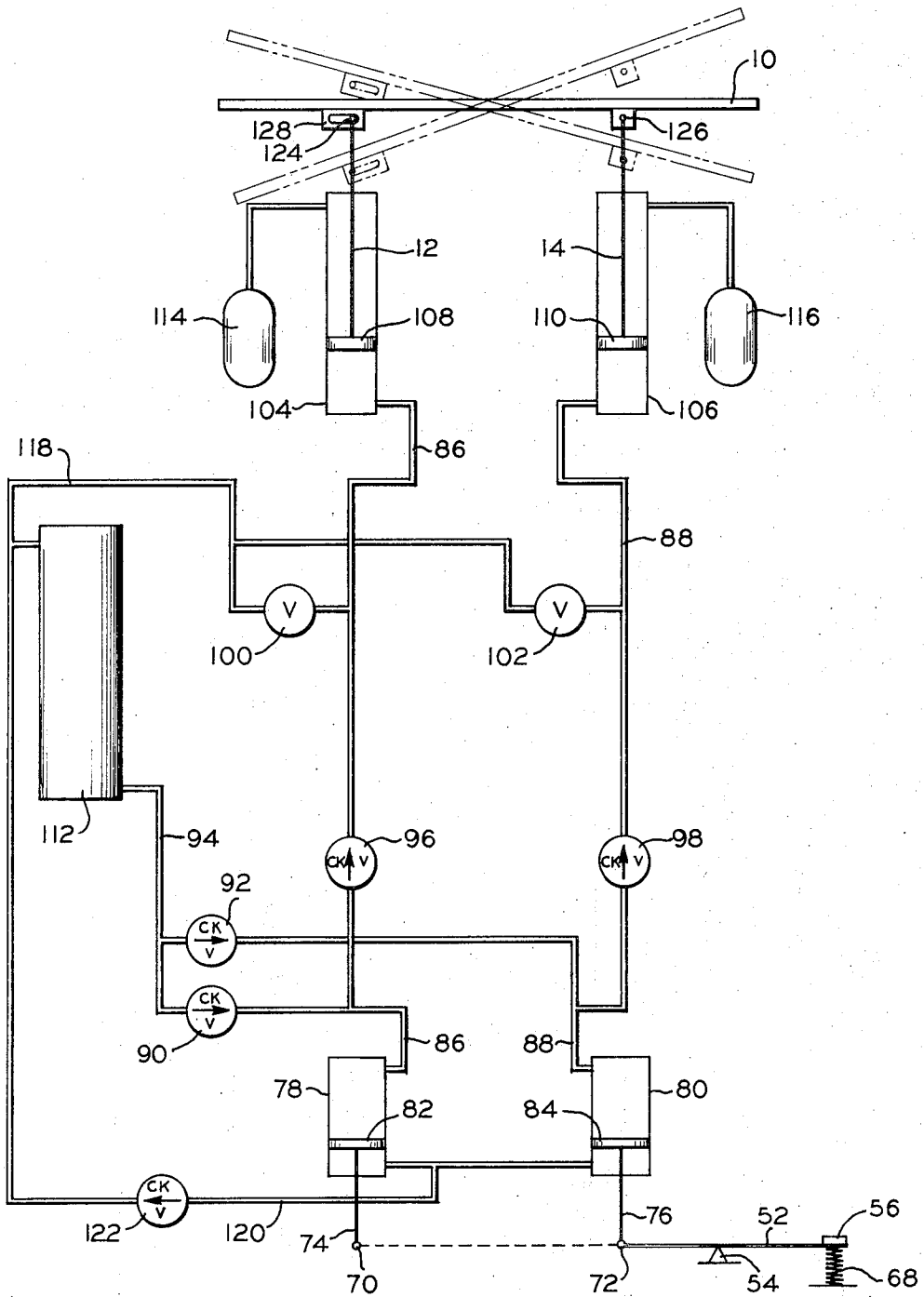

FIG. 3

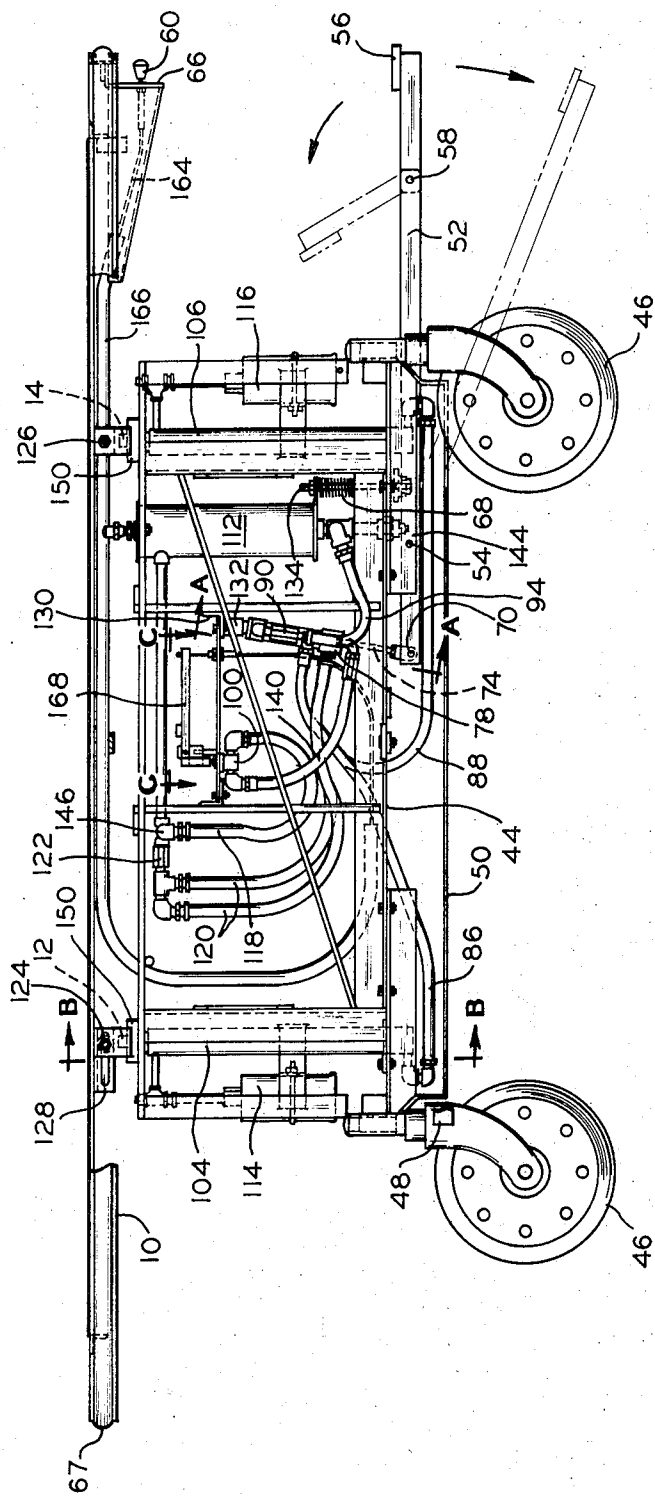

FIG. 4

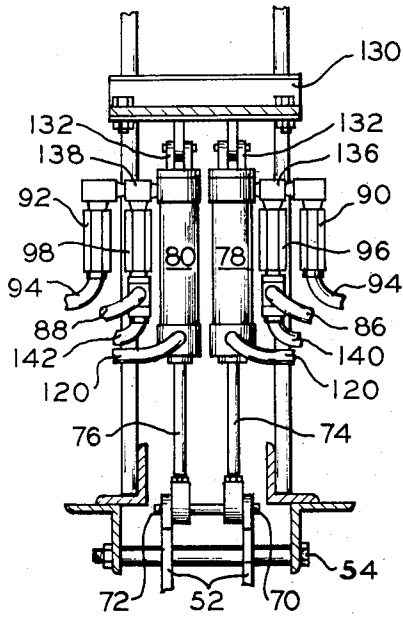

FIG. 5

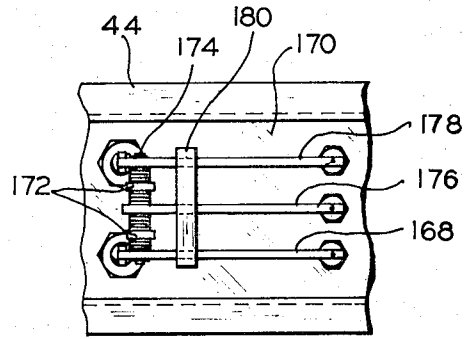

FIG. 7

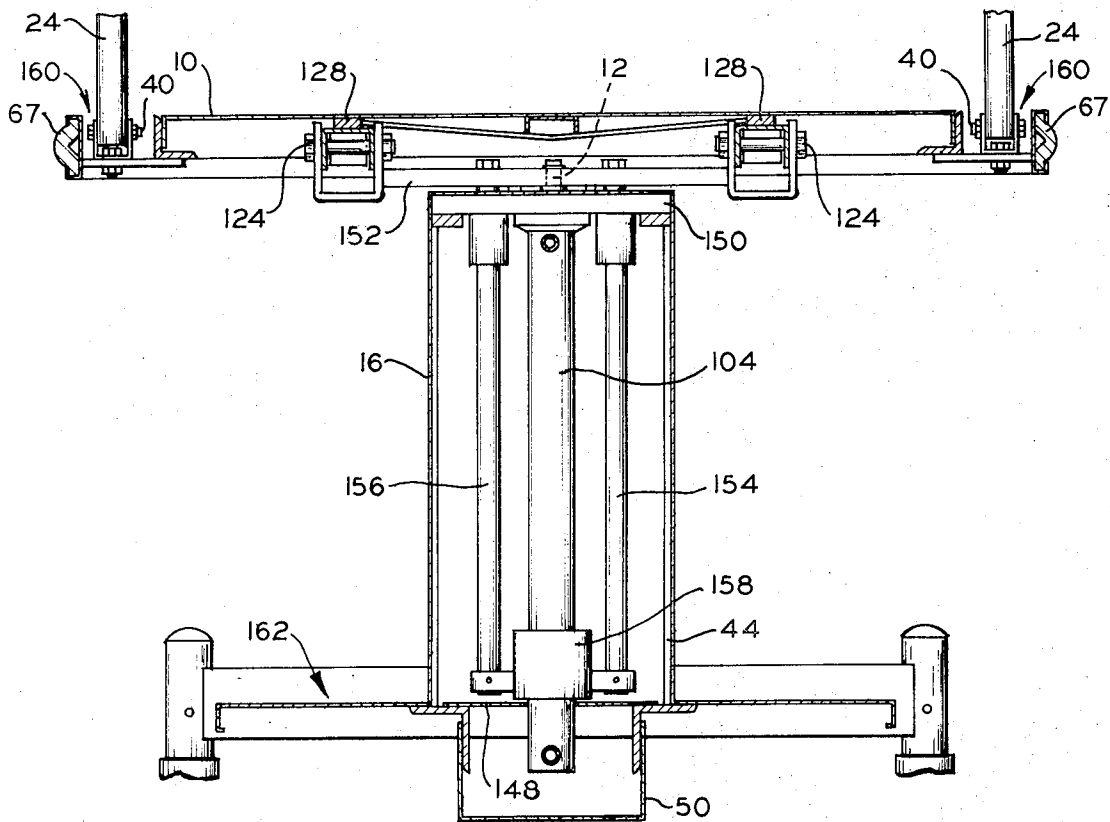

FIG. 6

HYDRAULIC SYSTEM FOR WHEELED STRETCHERS

FIELD OF THE INVENTION

The invention relates to a system for rapidly raising, tilting and lowering the patient supporting surface of a wheeled stretcher. Rapid tilting and lowering is especially important in the event that a patient suddenly goes into shock so that a trendelenburg position can be achieved almost instantaneously.

DESCRIPTION OF THE PRIOR ART

Previous to the introduction of hydraulically actuated stretchers, mechanical lift stretchers were utilized in hospitals. The operation of the mechanical stretchers was slow and the systems were difficult for the attendants to use. The hydraulically operated stretcher greatly improved the patient handling speed and increased the efficiency of the hospital. However, many hydraulic stretchers retained a mechanical or manual method of achieving the trendelenburg position. In order to improve the speed of the tilt operation some designs employed hydraulic actuation but over lubricated the hydraulic cylinder guiding system to decrease the lowering effort. The resulting operation remained relatively slow, inefficient and unclean due to the excess lubricant.

SUMMARY OF THE INVENTION

It is a principal object of this invention to provide a fully hydraulic wheeled stretcher with increased operating efficiency.

It is another object of the invention to provide a fast acting lifting and lowering mechanism for the patient supporting surface.

A further object of the invention is to provide a wheeled stretcher with a streamlined appearance and easy to clean exterior.

It is another object of this invention to provide a hydraulically actuated wheeled stretcher which is simple to operate.

DESCRIPTION OF THE DRAWINGS

FIG. 1 is a side elevation of the hydraulically operated wheeled stretcher according to the preferred embodiment.

FIG. 2 is an end elevation of the structure in FIG. 1.

FIG. 3 is a schematic of the hydraulic system for actuating the patient supporting surface.

FIG. 4 is a fragmentary side view of the stretcher.

FIG. 5 is a sectional view of the pump cylinders taken along line A—A of FIG. 4.

FIG. 6 is a sectional view of a lift cylinder taken along line B—B of FIG. 4.

FIG. 7 is a sectional view of the control linkage taken along line C—C of FIG. 4.

DESCRIPTION OF THE PREFERRED EMBODIMENT

FIG. 1 is a side view of the invention according to the preferred embodiment. The patient supporting surface 10 is attached to the upper ends of piston rods 12 and 14 of two hydraulic lift cylinders concealed by cover 16. These hydraulic cylinders are utilized to raise, lower or tilt the supporting surface to the desired posi-

tion. The cover 16 encloses the hydraulic system on four sides and the top and is constructed from a material which is easy to clean, yet light and strong, such as stainless steel. The supporting surface 10 is covered by a cushion 18 for patient comfort.

A side rail 20, one on either side of the stretcher, prevents the patient from rolling off the supporting surface 10. The side rail comprises a horizontally positioned bar 22 pivotally attached to four vertical bars 24, 26, 28 and 30 at pivot points 32, 34, 36 and 38. The opposite end of each vertical bar is pivotally attached to the supporting surface, for example at 40, so that as these vertical bars are rotated in a counter clockwise direction about the lower pivot points, horizontal bar 22 will be lowered. In the lowered position side rail 20 allows the patient to be easily transferred from the supporting surface 10. A lock 42 may be used to maintain side rail 20 in the raised position.

The supporting surface 10 and its associated hydraulic system are attached to a frame 44. The frame has four castoring wheels 46 which allow the stretcher to be steered in any direction. Two of the wheels have a foot operated brake 48 which prevents movement of the stretcher, for example, during treatment of the patient. Also attached to the frame 44 is a drip pan 50 which catches any excess oil and grease from the hydraulic system. Drip pan 50 has been cut away to show that lever 52 is pivotally attached to frame 44 at pivot point 54. The hydraulic lift cylinders are actuated by downward pressure on pedal 56. Pedal 56 is pivotally attached to lever 52 at point 58 so that it may be folded out of the way when not in use.

FIG. 2 is an end view of the invention shown in FIG. 1. Control knobs 60, 62 and 64 are mounted on control housing 66. Knob 60 controls the operation of the front hydraulic cylinder, knob 64 controls the operation of the rear hydraulic cylinder and knob 62 controls the operation of both cylinders simultaneously. The control knobs are of the "push-pull" type. When it is desired to raise the supporting surface 10 in a horizontal position all knobs are pushed in. To automatically lower the supporting surface knob 62 is pulled out. After supporting surface 10 has been raised, the trendelenburg position may be achieved in either direction by pulling out knob 60 or knob 64. The trendelenburg position is a position of the body for medical examination in which the patient is placed head down on a table inclined at about 20° from the horizontal with the knees uppermost and the legs hanging over the end of table. Either end of supporting surface 10 may be lowered to achieve a plurality of angles from the horizontal up to a predetermined maximum angle to facilitate examination or to treat shock.

The edges of supporting surface 10 are also provided with an elastic bumper strip 67. This bumper strip cushions the shock from impact with other objects and protects the patient and supporting surface 10.

FIG. 3 is a schematic representation of the hydraulic system. A pumping action on pedal 56 will cause supporting surface 10 to rise on piston rods 12 and 14 until the maximum height is reached. Manually operated two-way valves control the lowering operation so that either end or both ends of the supporting surface 10 may be lowered.

Lever 52 is pivoted about point 54 by downward pressure on pedal 56. When the pressure is released return spring 68 restores the lever 52 to its original posi-

tion. Pivotaly attached to lever 52 at points 70 and 72 are piston rods 74 and 76 of hydraulic pumps 78 and 80. Each hydraulic pump contains hydraulic fluid above the pistons 82 and 84. Downward pressure on pedal 56 causes piston rods 74 and 76 to travel in an upward direction and the hydraulic fluid is forced from the pumps 78 and 80 into lines 86 and 88. Check valves 90 and 92 allow passage of fluid only in the direction of the arrow so the fluid cannot pass into line 94. Instead the fluid passes through check valves 96 and 98. Two-way valves 100 and 102 are controlled by control knobs 60 and 64 individually and by control knob 62 collectively. If it is desired to raise the supporting surface 10, all control knobs are pushed in and fluid will not flow through the valves 100 and 102. The only path for the fluid then is into the bottom of lift cylinders 104 and 106 where it forces pistons 108 and 110 in an upward direction raising supporting surface 10. On the downward stroke of each pump piston the hydraulic fluid which has been forced into lift cylinders 104 and 106 is prevented from returning by check valves 96 and 98. However, the fluid is replaced in pumps 78 and 80 from reservoir 112 through line 94 and check valves 90 and 92. The process is repeated for each pumping stroke on pedal 56. Pumps 78 and 80, lines 86 and 88, valves 90, 92, 96, 98, 100 and 102 and lift cylinders 104 and 106 are of sufficiently strong construction that they will withstand the maximum pressure produced by continued pumping after supporting surface 10 has reached its highest position.

If it is desired to lower either end of supporting surface 10, or both ends simultaneously, the appropriate control knobs are pulled out. This will open either or both valves 100 and 102. Accumulators 114 and 116 are connected to the upper chambers of lift cylinders 104 and 106. When the pistons 108 and 110 are at the bottom of the lift cylinders, the upper chambers of the lift cylinders and the accumulators are filled with a gas, for example nitrogen, at a precharge pressure of approximately 40 psi. As the pistons 108 and 110 are forced upwardly, the gas is compressed and the pressure is increased. Now, when the two-way valves 100 and 102 are opened the gas will force pistons 108 and 110 downwardly. Since the hydraulic fluid cannot pass through check valves 96 and 98, the fluid will be returned to the reservoir 112 through line 118 where it will be available to pumps 82 and 84 for the time when supporting surface 10 is to be raised.

Although the pistons in both the pumps and the lift cylinders are sealed against the passage of the hydraulic fluid some fluid will leak between them and the cylinder or pump wall. In the lift cylinders 104 and 106, fluid which is trapped in the upper chamber will be forced into the accumulators 114 and 116 where it will remain. In the pumps 78 and 80 the trapped fluid is forced through line 120 on the downstroke to the reservoir 112. Any return of the fluid is prevented by check valve 122.

In order to achieve the trendelenburg position, the supporting surface 10 is pivotaly attached to piston rods 12 and 14 at pivot points 124 and 126. The front pivot point 124 is also slidably movable in block 128. As either end of supporting surface 10 is lowered, pivot point 124 will move from the back toward the front of block 128 so that piston rods 12 and 14 remain parallel to one another. The length of the slot in block 128 will

determine the maximum angle at which the supporting surface 10 may be tilted.

FIG. 4 is a fragmentary side view of the stretcher with cover 16 removed showing the relationship of the hydraulic system to the frame 44 and the supporting surface 10. Downward pressure on pedal 56 rotates lever 52 about pivot point 54. The opposite end of lever 52 is pivotaly attached to piston rod 74 at point 70. The downward movement of pedal 56 forces piston rod 74 into pump 78 causing hydraulic fluid to be expelled from the outlet of the pump. The upper end of pump 78 is pivotaly attached to bracket 130 at point 132 to maintain axial alignment between pump 78 and piston arm 74 as lever 52 rotates. Bracket 130 is firmly attached to frame 44. Return spring 68 has its lower end attached to frame 44 and its upper end to rod 134. The lower end of rod 134 is attached to lever 52 so that when pedal 56 is pushed down rod 134 is pulled down and spring 68 is compressed. When the pressure on pedal 56 is released spring 68 returns lever 52 to its horizontal position.

FIG. 5 is a sectional view of the pump cylinders taken along line A—A of FIG. 4. Front hydraulic pump 78 and rear hydraulic pump 80 are connected in parallel at pivot points 70 and 72 to lever 52. Pumping action of lever 52 about pivot point 54 moves piston rods 74 and 76 in unison. The upper ends of both pumps are pivotaly connected to bracket 130 at pivot point 132. As piston rods 74 and 76 are forced into the pumps hydraulic fluid is expelled into three-way fittings 136 and 138. Connected to one opening of fittings 136 and 138 are check valves 96 and 98. The fluid from the pumps proceeds through check valves 96 and 98 into lines 86 and 88 which are connected to the front and rear lift cylinders. The fluid is also available in lines 140 and 142 which are connected between check valves 96 and 98 and the two-way valves. If the supporting surface 10 is being raised the two-way valves will be closed and there will be no fluid flow through lines 140 and 142.

The other opening of three-way fittings 136 and 138 is connected to check valves 90 and 92. On the downward stroke of piston rods 74 and 76, the expelled fluid is replaced from the reservoir through lines 94. If any fluid leaks past the pump pistons into the lower portion of the pump it is returned to the reservoir by lines 120.

Returning to FIG. 4, it is shown that line 94 connects check valve 90 to the lower input of reservoir 112 which is firmly attached to frame 44 at its upper end. The lower input to reservoir 112 also has a drain 144 for releasing the hydraulic fluid. The upper input to the reservoir is connected to a four-way fitting 146. Two of the openings of fitting 146 are connected to lines 118 which in turn are connected to two-way valves. When it is desired to lower one or both ends of supporting surface 10 one or both of the two-way valves are opened and fluid from the lift cylinders can flow to the reservoir. For example, if valve 100 is opened fluid from lift cylinder 104 can flow through lines 86, 140 and 118 to reservoir 112. The other opening of fitting 146 is connected to check valve 122 which only allows fluid to flow to the reservoir from lines 120. This is the return for the fluid which may leak past the pump pistons.

Lines 86 and 88 are connected to the front lift cylinder 104 and rear lift cylinder 106. Fluid from the pumps causes piston rods 12 and 14 to rise. Accumula-

tors 114 and 116, which are precharged with nitrogen, are securely fastened to frame 44. The pressure from the nitrogen gas aids in lowering the supporting surface 10 by forcing the pistons of lift cylinders 104 and 106 downwardly. The cylinder rods 12 and 14 are pivotally attached to supporting surface 10 at points 124 and 126. In addition pivot point 124 is free to slide in the slot of block 128 when supporting surface 10 is tilted.

FIG. 6 is a sectional view of the front lift cylinder and its mounting taken along line B—B of FIG. 4. Lift cylinder 104 is secured to frame 44 by lower mounting plate 148 and upper guide bracket 150. Piston rod 12 is firmly attached to support bracket 152. Support bracket 152 is pivotally attached at pivot points 124 to blocks 128 which in turn are firmly attached to supporting surface 10. Also attached to supporting bracket 152 are the upper ends of guide rods 154 and 156. Guide rods 154 and 156 are free to pass through upper guide bracket 150. At their lower ends the guide rods are attached to lower guide bracket 158 which is free to slide axially along the exterior surface of lift cylinder 104. Therefore, as piston rod 12 extends and retracts guide rods 154 and 156 move in unison with it to prevent sideward movement of the supporting surface 10 with its undesirable side loading on lift cylinder 104.

Also shown in FIG. 6 are several features not evident in other views. Vertical bar 24 of the side rail is pivotally attached to supporting surface 10 at pivot point 40. When the side rail is lowered the bar 24 rests in a horizontal position in channel 160 so that the side rail will not interfere with the removal of a patient from the stretcher. Cover 16 is shown attached to one side of frame 44. The cover may be formed so that it provides a shelf in area 162 for use when it is required to transport equipment with the patient. Another feature is drip pan 50, with one side cut away, which traps grease and oil from the hydraulic system and prevents it from falling on the floor.

Control knob 60 of FIG. 4 is connected to one end of cable 164. Cable 164 along with the cables for knobs 62 and 64 passes through cable enclosure 166 to a control linkage for two-way valves 100 and 102. The end of each cable is attached to one end of a link arm, cable 164 being attached to link arm 168, whose other end is pivoted along a horizontal axis. The pivot ends of the control levers for knobs 60 and 64 are also attached to two-way valves 100 and 102.

FIG. 7 is a sectional view of the control linkage along line C—C of FIG. 4. Mounting plate 170 is attached to frame 44. Linkage pivot 172 is firmly fixed to mounting plate 170 and has shaft 174 which is free to rotate. Control levers 168, 176 and 178 are pivotally attached to shaft 174 and are approximately equally spaced apart thereon. The ends of the control levers opposite the pivot points are attached to cables from the control knobs. Lever 168 is attached to cable 164 from control knob 60. Lever 176 is attached to the cable from control knob 62 and lever 178 is attached to the cable from control knob 64. When a control knob is pulled out the corresponding control lever will be pulled down and when the control knob is pushed in the control lever will return to a horizontal position.

As was stated previously, when all the control knobs are pushed in the supporting surface 10 will rise maintaining a horizontal position. If it is desired to lower the front end of the stretcher, control knob 60 is pulled

out. This causes control lever 168 to be pulled down. The pivot end of control lever 168 is attached to two-way valve 100 in such a manner that when control lever 168 is horizontal valve 100 is closed and when control lever 168 is pulled down valve 100 is open. Thus, when control knob 60 is pulled out, lift cylinder 104 lowers the front of supporting surface 10. If it had been desired to lower the rear instead, control knob 64 would have been pulled out. Then control lever 178, which is attached to two-way valve 102, would have been pulled down and lift cylinder 106 would lower the rear of supporting surface 10. In order to lower the supporting surface 10 in a horizontal position control knob 62 must be pulled out. This lowers control lever 176. Control lever 176 has a cross-bar 180 which extends over levers 168 and 178. When control lever 176 is lowered the cross-bar 180 also lowers control arms 168 and 178 causing both lift cylinders to lower simultaneously. Thus, simply by pulling out one control knob the patient may be tilted in either direction or lowered smoothly yet rapidly.

In accordance with the provisions of the patent statutes, I have explained the principle and mode of operation of my invention and have illustrated and described what I now consider to represent its best embodiment. However, I desire to have it understood that the invention may be practiced otherwise than as specifically illustrated and described without departing from its spirit and scope.

What I claim is:

1. In a wheeled stretcher having a patient supporting platform, a load-supporting wheeled frame, and two vertically adjustable supports fixedly attached to and longitudinally spaced on said frame and pivotally attached to said platform, a hydraulic lift system comprising:

- two hydraulic lift cylinders, one for adjusting the height of each of said supports;
- two hydraulic pumps, one connected to each of said lift cylinders;
- means for operating said pumps in unison;
- a fluid reservoir connected to said pumps;
- two manually actuated normally closed valves, one connected between each of said cylinders and said reservoir for venting said cylinders to said reservoir;
- means to actuate said valves separately and in unison; and
- storage means connected to each of said lift cylinders to store a compressible fluid for assisting said lift cylinders during the lowering mode of operation when at least one of said normally closed valves is opened.

2. A system according to claim 1 wherein said means for operating said pumps includes a pedal-operated lever with a return spring.

3. A system according to claim 1 wherein said means to actuate said valves includes three push-pull control knobs, cables attached to each of said knobs, and levers attached to each of said cables whereby one each of said levers actuates one of said valves and the third of said levers actuates the other two levers in unison.

4. A system according to claim 3 wherein said valves are closed when said levers are pushed in and are open when said levers are pulled out.

5. A system according to claim 1 wherein said storage means is an accumulator.

6. A system according to claim 5 wherein said compressible fluid is a liquid.

7. A system according to claim 5 wherein said compressible fluid is a gas.

8. A system according to claim 7 wherein said gas is nitrogen.