

(19) World Intellectual Property Organization  
International Bureau



(43) International Publication Date  
8 May 2003 (08.05.2003)

PCT

(10) International Publication Number  
WO 03/038367 A1

- (51) International Patent Classification<sup>7</sup>: **F41B 11/06**, F42B 6/00, 30/04, 30/10, B64G 1/10, F41A 21/02
- (21) International Application Number: PCT/AU02/01492
- (22) International Filing Date:  
1 November 2002 (01.11.2002)
- (25) Filing Language: English
- (26) Publication Language: English
- (30) Priority Data:  
PR 8659 2 November 2001 (02.11.2001) AU
- (71) Applicant (for all designated States except US): **POLY SYSTEMS PTY LIMITED** [AU/AU]; Main Road, George Town, TAS 7253 (AU).
- (72) Inventor; and
- (75) Inventor/Applicant (for US only): **WEBB, Roger, Clyde** [AU/AU]; 20 St Helen Street, Lindisfarne, TAS 7015 (AU).
- (74) Agent: **HODGKINSON OLD McINNES**; Level 3, 20 Alfred Street, Milsons Point, NSW 2061 (AU).
- (81) Designated States (national): AE, AG, AL, AM, AT, AU, AZ, BA, BB, BG, BR, BY, BZ, CA, CH, CN, CO, CR, CU, CZ, DE, DK, DM, DZ, EC, EE, ES, FI, GB, GD, GE, GH, GM, HR, HU, ID, IL, IN, IS, JP, KE, KG, KP, KR, KZ, LC, LK, LR, LS, LT, LU, LV, MA, MD, MG, MK, MN, MW, MX, MZ, NO, NZ, OM, PH, PL, PT, RO, RU, SD, SE, SG, SI, SK, SL, TJ, TM, TN, TR, TT, TZ, UA, UG, US, UZ, VC, VN, YU, ZA, ZM, ZW.
- (84) Designated States (regional): ARIPO patent (GH, GM, KE, LS, MW, MZ, SD, SL, SZ, TZ, UG, ZM, ZW), Eurasian patent (AM, AZ, BY, KG, KZ, MD, RU, TJ, TM), European patent (AT, BE, BG, CH, CY, CZ, DE, DK, EE, ES, FI, FR, GB, GR, IE, IT, LU, MC, NL, PT, SE, SK, TR), OAPI patent (BF, BJ, CF, CG, CI, CM, GA, GN, GQ, GW, ML, MR, NE, SN, TD, TG).
- Published:**  
— with international search report
- For two-letter codes and other abbreviations, refer to the "Guidance Notes on Codes and Abbreviations" appearing at the beginning of each regular issue of the PCT Gazette.

(54) Title: PROJECTILE FIRING DEVICE USING LIQUIFIED GAS PROPELLANT

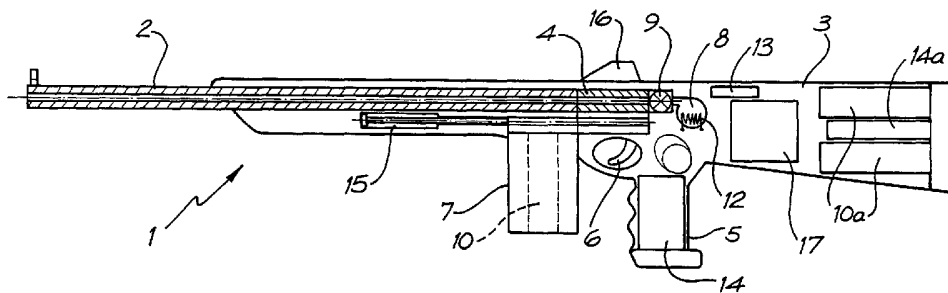

(57) Abstract: Rifle (1) comprises barrel (2) and loading means (15) for introducing a projectile from magazine (7) into breech (4). The projectile is propelled by a compressed gas propellant initially stored as a liquid in canister (10). The liquid is heated to a super critical state in chamber (8) by heating element (12) to induce a phase change such that the liquid becomes a highly dense gas. The phase change from liquid to gas provides the energy required to expel the projectile at high velocity from rifle (1), regardless of the ambient temperature. The propellant is preferably CO<sub>2</sub> which is heated to 31.06 °C. Rifle (1) produces minimal noise and no heat signature, making it suitable for military and stealth purposes. A pistol and launchers for grenades or mortar bombs are also disclosed. Another version can launch low earth orbit satellites or payloads.



WO 03/038367 A1

## PROJECTILE FIRING DEVICE USING LIQUIFIED GAS PROPELLANT

### TECHNICAL FIELD

The present invention relates to a projectile firing device, and more particularly to such  
5 a device that uses a propellant that is initially stored in a liquid phase and undergoes a  
phase change to a "highly dense" gas to effect propulsion of the projectile. The  
projectile firing device may in number of embodiments relate to a weapon such as a  
gun, rifle, pistol, grenade or mortar launcher. In another embodiment the projectile  
firing device may be used as a low earth orbit satellite-launch device.

10

### BACKGROUND

Conventional weapons such as rifles and guns use gunpowder or cordite as the  
explosive material to propel ammunition. Such explosive materials provide a violent  
expansion of gases and the liberation of relatively large amounts of thermal energy to  
15 achieve propulsion of the ammunition. There are a number of disadvantages associated  
with such conventional weapons. Firstly, they are highly inefficient in energy transferral  
from the explosive material to the projectile velocity of the ammunition. In many  
instances only 20-40% of the energy released by the exploding material is transferred to  
the projectile velocity.

20 A number of other disadvantages associated with conventional guns and rifles are the  
emission of large amounts of thermal energy (heat) and noise that can be easily detected  
with and without the aid of conventional detection equipment. Also, due to the large  
amounts of thermal energy being released the barrel and breech of a conventional gun or  
rifle must be able to withstand high temperatures and therefore are typically made of  
25 steel.

There are known guns that utilise a compressed gas, such as carbon dioxide (CO<sub>2</sub>) to  
effect propulsion of a projectile. Such arrangements use CO<sub>2</sub> in a gaseous state stored in  
a canister that is removably attached to the gun. Known guns that use such an

arrangement are spear guns and paintball guns. However, such arrangements are not suitable for high velocity weapons of the type used for military purposes.

Attempts have been made in the past to heat the gas propellant of gas powered projectile firing devices. US Patent No. 5,462,042 (Greenwell) describes a CO<sub>2</sub> powered paint ball gun in which CO<sub>2</sub> is initially stored in a conventional CO<sub>2</sub> cartridge. The initial expansion of the chilled CO<sub>2</sub> occurs in an expansion chamber in the form of a passage which passes through the hand grip 16 and may be warmed by the heat of a user's hand. This arrangement is to speed up the heating of the CO<sub>2</sub> prior to firing of the gun.

German Patent Application DE 3733-240 (Steyr-Daimler-Punch AG) describes a gun using a liquefied gas propellant. The gun has a heater for heating gas as it passes through a tube towards the propellant chamber. The gas is heated on its way to the propellant chamber to enhance precision of the gun by compensating for temperature changes which affect the liquid-gas propellant.

The above described prior art guns utilise heating arrangements that provide heat to the propellant gas prior to it reaching the propellant chamber, in an attempt to overcome firing problems that may occur at colder ambient temperatures. However, these heating arrangements suffer from the disadvantage that they do not ensure reliable repeated firing of a gun over a wide range of cold ambient temperatures.

The present invention seeks to provide a projectile firing device that overcomes the disadvantages associated with conventional weapons and with known gas powered projectile firing devices as described above. It also seeks to provide a means for other projectile firing applications such as launching low earth orbit satellites and payloads.

## **SUMMARY OF THE INVENTION**

According to a first aspect the present invention is a projectile firing device comprising:

an elongate barrel through which a projectile is fired;

loading means for introducing said projectile into said barrel;

said projectile being adapted to be propelled by a compressed gas propellant,  
characterised in that said compressed gas propellant is initially stored as liquid  
and adapted to be heated by a heating means which induces a phase change such  
that said propellant becomes a highly dense gas.

5 Preferably in one embodiment said device comprises at least one chamber for holding  
said compressed gas propellant, said chamber being in fluid communication with said  
barrel via a valve means adapted to release said compressed gas propellant to fire said  
projectile held in said barrel, and a reservoir located remote from said chamber for  
storing said propellant in its initial liquid state, and a means for introducing said  
10 propellant in its liquid state from said reservoir into said chamber.

Preferably said device is a weapon, such as a rifle, gun or pistol. Preferably said barrel  
of said weapon is made of a composite material such as kevlar/aluminium laminate and  
metals such as steel, and said barrel has a teflon coated bore. Preferably where said  
device is a rifle it has a body, stock and pistol grip made of plastic, such glass filled  
15 nylon.

Alternatively, said device is a satellite-launch device and said projectile is a low earth  
orbit satellite. Preferably said satellite-launch device comprises a plurality of modular  
units and a plurality of chambers. Preferably each chamber is associated with at least  
one modular unit.

20 A projectile firing device as described in any of the abovementioned embodiments  
wherein said device further comprises an electronic control unit, which controls the  
ingress of the propellant in its liquid state from the reservoir to said chamber and  
controls the heating means used to heat said propellant. Preferably where said projectile  
firing device is a weapon or satellite launching device it further comprises targeting  
25 means for targeting said projectile and said electronic control unit is operably connected  
to said targeting means to control ingress of said propellant to said chamber and to  
control the heating means used to heat said propellant in response to varying targeting  
parameters.

In another embodiment of said projectile firing device, said projectile is housed within  
30 a cartridge, said cartridge containing a reservoir of propellant in its initial liquid state

and a thermal detonator adjacent thereto, said heating means adapted to heat said thermal detonator which in turn heats propellant. Preferably said device is a weapon, such as a grenade launcher.

In a further embodiment of said device, said projectile is housed within a cartridge, said  
5 cartridge containing a reservoir of propellant in its initial liquid state and at least a portion of said heating means adapted to heat said propellant is integral with said cartridge. Preferably said cartridge uses a portion of the explosive energy of the propellant to continue acceleration of the projectile for a period of time after the projectile has left said device. Preferably said device is a weapon, such as a mortar  
10 launcher.

A projectile firing device as defined in any of the abovementioned embodiments wherein said device further comprises an electronic control unit, which controls the ingress of the propellant in its liquid state from the reservoir to said chamber and controls the heating means used to heat said propellant.

15 According to a second aspect the present invention comprises a projectile firing device comprising:

an elongate barrel through which a projectile is fired;

loading means for introducing said projectile into said barrel;

20 at least one chamber for holding a compressed gas propellant, said chamber being in fluid communication with said barrel via a valve means being adapted to release said compressed gas propellant to fire a projectile held in said barrel;

characterised in that said compressed gas propellant is initially a liquid stored in a reservoir remote from said chamber, said propellant in its liquid form being adapted to be introduced into said chamber and heated therein by a heating  
25 means that induces a phase change in the propellant from a liquid to a highly dense gas.

Preferably in any of the abovementioned embodiments said propellant is carbon dioxide.

**BRIEF DESCRIPTION OF THE DRAWINGS**

The invention will now be described with reference to drawings in which:

5 Fig. 1 is a schematic elevational view of a rifle according to a first embodiment of the present invention.

Fig. 2 is a plan view of the rifle shown in Fig.1.

Fig. 3 is an end view of the rifle shown in Fig. 1.

Fig. 4 is a plan schematic of magazine and CO<sub>2</sub> cannister of the rifle shown in Fig. 1.

10 Figs. 5 to 8 are enlarged partial elevational schematics detailing various stages of loading and firing a projectile in the rifle shown in Fig. 1.

Fig. 9. is a schematic elevational view of a pistol according to a second aspect of the present invention.

Fig. 10 is an end view of the pistol shown in Fig. 9.

15 Fig. 11 is a schematic elevational view of a gun according to a third embodiment of the present invention.

Fig. 12 is a schematic elevational view of a grenade launcher according to a fourth embodiment of the present invention.

Fig. 13 is a plan view of the grenade launcher shown in Fig.12.

Fig. 14 is an end view of the grenade launcher shown in Fig. 12.

20 Fig. 15 is an enlarged schematic view of a cartridge used in the grenade launcher of Fig 12.

Fig. 16 is a schematic elevational view of a mortar launcher according to a fifth embodiment of the present invention which can be used both by stand and hand held.

Fig. 17 is a schematic elevational view of a mortar launcher of the mortar of launcher shown in Fig.16 when in a folded orientation for shoulder use by an infantryman.

Fig. 18 is a simplified front view the mortar launcher shown in Fig. 16.

Fig. 19 is a simplified front view the mortar launcher shown in Fig. 18.

5 Fig.20 is a sectional view of the mortar launcher body shown in Fig.18.

Fig.21 is a planview of the mortar launcher base shown in Fig.18.

Fig.22 is an enlarged cross-sectional view of a mortar projectile for the mortar launcher of Fig.18.

Fig.23 is an aft end view of the mortar projectile shown in Fig.22.

10 Fig.24 is a schematic elevational view of a satellite-launch device according to a sixth embodiment of the present invention.

Fig 25 is a schematic enlarged elevational view of a modular unit of the satellite-launch device shown in Fig 24.

15 Fig 26. is an enlarged plan view of a burst disc component of the modular unit shown in Fig 25.

Fig.27 is an enlarged cross-sectional view of a satellite and carrier to be launched for the satellite-launch device of Fig.24.

## **MODE OF CARRYING OUT INVENTION**

20 Figures 1 to 4 depicts a rifle 1 and its ammunition in accordance with a first embodiment of a projectile firing device of the present invention. In a similar manner to conventional rifles, rifle 1 has a rifled barrel 2, stock 3, breech 4, pistol grip 5, trigger mechanism 6 and removable ammunition magazine 7.

Rifle 1 also has a high-pressure chamber 8 in fluid communication with barrel 2, via a gas lock off-valve 9. A canister 10 containing liquid carbon dioxide (CO<sub>2</sub>) is integrally housed within magazine 7.

The rifle 1 fires an ammunition projectile 11 loaded into breech 4 in the following manner. The liquid CO<sub>2</sub> contained in canister 10 is the propellant used to fire projectile 11. Liquid CO<sub>2</sub> is introduced into chamber 8 from canister 10. The fluid communication means between canister 10 and chamber 8 has been omitted from the figures for the purpose of clarity. The liquid CO<sub>2</sub> in chamber 8 is heated by a heating element 12 that is powered by an electrical battery power supply 14 housed within pistol grip 5.

When CO<sub>2</sub> is heated to 31.06°C, it changes to a “super critical state” which is a “highly dense” gas at high pressure. In this embodiment the critical state of CO<sub>2</sub> as it changes phase from liquid to a gas, provides the explosive energy required to expel projectile 11 at high velocity from rifle 1, regardless of the ambient temperature. This explosive process which fires projectile 11, occurs with minimal noise and no heat signature emitting from rifle 1, thereby making rifle 1 advantageous when used for military and stealth purposes.

The following table depicts the temperature/pressure relationship of Liquid/gas CO<sub>2</sub>.

| Temperature (°C) | Pressure (bar) |                |
|------------------|----------------|----------------|
| 21               | 54             |                |
| 31               | 74             | Critical point |
| 100              | 250            |                |
| 500              | 1250           |                |
| 1000             | 2500           |                |

The suitability of CO<sub>2</sub> as a preferred propellant can be appreciated by the following:

- 1 gram of liquid CO<sub>2</sub> will liberate to 500cc of gas at 25°C
- 1 gram of CO<sub>2</sub> = 0.759cc at 25°C



- 1cc of liquid CO<sub>2</sub> will liberate to 660cc at 25°C

In use rifle 1, operates as follows with reference to Figures 5-8. A pneumatic loading mechanism 15 is used to load a projectile 11 contained in magazine 7 into breech 4. When breech 4 is lowered into the loading position as shown in figure 6, the targeting system sight module 16 and of a laser sight generator 13 is activated and reflected up  
5 barrel 2.

An electronic module or electronic control unit (ECU) 17 is operably connected to sight module 16 and a Global Positioning System (GPS) as well as operably connected to the CO<sub>2</sub> supply and chamber 8. ECU 17 adjusts and monitors targeting, CO<sub>2</sub> supply and  
10 pressures to match the CO<sub>2</sub> requirements to that of the distance of the target. In addition the ECU 17 is operably connected to other components within rifle 1 and may control and monitor electric power supply, projectiles and possible communication systems integrated within the rifle.

When a target is acquired by the user of rifle 1, through sight module 16, GPS and  
15 targeting information is in view to the user of the rifle 1 via a heads up display within sight module 16. Adjustment of laser positioning and prism angles for target acquisition occurs instantaneously, and target information may preferably be electronically processed via processing devices used for focussing and triangulation of known electronic video or still cameras.

20 As the targeting system is operational, a metered amount of liquid CO<sub>2</sub>, say for example 5cc, is allowed to enter chamber 8. A small current is passed through heating element 12. The heating of the liquid CO<sub>2</sub> results in its pressure building up in a fraction of a second.

When trigger mechanism 6 is pulled, breech 4 returns to the firing position as shown in  
25 Figure 7. Gas lock-off valve 9 activates the CO<sub>2</sub> at the critical state at which it is a highly dense gas and projectile 8 is dispatched at high velocity as shown in Figure 8.

Preferably as projectile 11 is forced up the bore of barrel 2, the rear of projectile is adapted to flare, to promote a good gas seal. The flaring action promotes a rotational motion from the rifling of barrel 2. Preferably both the barrel 2 and projectile 11 are

coated with Teflon to minimize bore wear. Driving bands may also be incorporated to assist spin on projectile 11.

As projectile 11 leaves rifle 1, residual pressure is used to reposition breech 4 to the reload position. The loading mechanism is reactivated and rifle 1 will then regain the target acquisition mode.

Preferably the rifle 1, can be used in a single shot mode, or an automatic mode when the trigger mechanism 6 is left in the fire position.

It should be understood that the various components of rifle 1 can be manufactured from lighter materials than those of conventional rifles, as the explosive release of energy of the CO<sub>2</sub> propellant in rifle 1 is more efficient, and therefore a number of the various components of rifle 1 do not have to be of the same material and heat resistant properties as that required in conventional high velocity rifles. For instance the chamber 8 may preferably be manufactured in titanium, stainless steel or aluminium to reduce bulk and to contend with extreme pressures, whilst the major part of the body including stock 3 and pistol grip 5 may preferably be manufactured from injection moulded glass filled nylon. Preferably the barrel 2 is made from an aluminium/kevlar laminate material with the bore of barrel 2 being coated with teflon and/or chrome-steel.

In addition to the CO<sub>2</sub> canister 10 and the battery pack power supply 14, rifle 1 is also equipped with auxiliary CO<sub>2</sub> charges 10a and a backup battery pack power supply 14a contained within stock 3, as shown in Figure 1.

Preferably breech 4 is an electromagnetic/pneumatic arrangement, with a mechanical override. The breech 4 may be manufactured from aluminium/kevlar laminate with a teflon coated bore.

The projectiles 11 which are fired from rifle 1 are preferably manufactured with a tip and central core of tungsten. The rear and outer body is made of kevlar, which is coated with teflon or teflon impregnated with carbon. The rear of the projectile is designed to flare and expand under high pressure to ensure a good gas seal, which also promotes projectile rotational motion, from the internal rifling of the bore of barrel 2.

It should be understood that rifle 1 as disclosed above may also be provided with conventional attachment points for a bayonet and hand grenade launcher and sling.

Figures 9 and 10 depict a pistol 21 in accordance with a second embodiment of a projectile firing device of the present invention. The pistol 21 like the rifle 1 fires an ammunition projectile 11 loaded into breech 4. In particular, pistol 21 also contains a liquid CO<sub>2</sub> canister 10 that is loaded into the pistol grip 25 along with magazine 7 containing projectiles 11. In a like manner to that of rifle 1, liquid CO<sub>2</sub> contained within canister 10 is introduced into chamber 8 and may be heated by a heating element 12 that is powered by an electrical battery power supply 14 housed within the body of pistol 21. The dispatch of projectiles 11 occurs in a similar manner to that in rifle 1 in that the liquid CO<sub>2</sub> is induced to change its state from a liquid to a "highly dense" gas.

Figure 11 depicts an artillery/naval gun 31 in accordance with a third embodiment of a projectile firing device of the present invention. The gun 31, like that of rifle 1 of the first embodiment utilises liquid CO<sub>2</sub> which is introduced into a chamber 8 and then heated to ensure a phase change to a "highly dense" gas. In addition to the primary chamber 8, the gun 31 may also be provided with secondary chambers 8a and 8b that are also loaded with liquid CO<sub>2</sub>. As a projectile dispatched by the explosive charge of CO<sub>2</sub> from the primary chamber 8 passes sensors 17A and 17B associated respectively with secondary chambers 8a and 8b, gas within those chambers is also released assisting in the dispatch of the projectile. Gun 31 may preferably have a barrel of approximately two metres in length. The firing of the primary chamber 8 followed by assistance to the projectile 11 via secondary chambers 8a and 8b is able to provide a higher velocity to the projectile 11 than would be achieved with a single chamber 8. As with rifle 1 of the first embodiment it is envisaged that a kevlar/aluminium composite could be used, thereby making the gun 31 up to five times the strength of steel for a given weight.

Figures 12-15 depict a grenade launcher 41 and ammunition fitted to rifle 1 of the first embodiment in accordance with a fourth embodiment of a projectile firing device of the present invention. In this embodiment the grenade launcher 41 is for launching grenade cartridges 11a each of which comprise a fore compartment 42, and aft compartment 43 and a central compartment 44 therebetween. The fore compartment 42 contains a detonator 45 and high explosive 46, the central compartment 44 contains a charge of

liquid CO<sub>2</sub>, and aft compartment 43 comprises of a magnesium compound thermal detonator. The fore compartment 42 is adapted to readily separate from central compartment 44.

5 In this embodiment the grenade launcher 41 utilises a heating element (not shown) operably connected to electrical battery power supply 14 or 14a of rifle 1, which is activated by trigger mechanism 6. The heating element is used to heat the aft compartment (magnesium compound thermal detonator) 43 of a grenade cartridge 11a in the loaded position. The heat generated by the magnesium compound thermal detonator is sufficient to ensure that the liquid CO<sub>2</sub> undergoes a phase change to a  
10 “highly dense” gas, thereby providing explosive energy that destructs central compartment 44 and separates fore compartment 42 therefrom, and expelling the fore compartment 42 containing detonator 45 and high explosive 46 as a projectile from grenade launcher 41 via its barrel 2a. The grenades cartridges 11a are carried by a carousel-magazine 47.

15 Figure 16 to 23, depict a mortar launcher 51 and mortar projectiles 11c in accordance with a fifth embodiment of a projectile firing device of the present invention. The mortar launcher 51 may typically be constructed of an aluminium/kevlar composite and comprise a high energy output battery pack 14b, electronic inclinometer, GPS and compass display 16b for accurate targeting, and a lightweight adjustable stand 52. Up to  
20 70% weight saving can be achieved by using the aluminium/kevlar composite materials to provide infantry with a more mobile mortar support facility. The tubular body of launcher 51 has an aluminium honeycomb central section 63 “sandwiched” between an inner Kevlar section 64 and an outer Kevlar section 62.

The mortar projectile 11c is a high explosive pre-shrapnel projectile comprising a front  
25 section 53 and a rear section 54. The front section 53 may be manufactured from steel containing high explosive 55 surrounded by pre-fragmented steel particles 56 (which can be replaced by magnesium composite to produce an incendiary device) and a detonator 57. The detonator 57 can be adjusted with a pre-set timer to detonate in-flight or upon impact.

30 The rear section 54, which may also be manufactured from steel, contains liquid CO<sub>2</sub>. This rear section also houses a magnesium-oxide composite with a soft metal failure

diaphragm 58 and four stability fins 59 with copper tipped electrodes. Surrounding the front and rear sections 53 and 54 are two nylon collar bands, coated with teflon or teflon impregnated with carbon.

5 The mortar launcher 51 typically set up and levelled by the use of adjustable support legs of stand 52. Angle of incline and positioning, adjusted by use of front support 52a, by the user referring to electronic inclinometer, GPS and compass display 16b mounted on the barrel. A laptop or hand-held computer could be used in conjunction with GPS and a Terrain Mapping program to calculate and pinpoint accuracy, and would be advantageous for "Terrain Impaired" hidden targets.

10 The projectile 11c is dropped into the top of the barrel 2c of launcher 52 and falls to its base. The fins 59 of projectile 11c, equipped with copper tipped electrodes 60, strike the electrode segments 61 situated at the base of launcher 51, making an electrical circuit as the electrode segments are operably connected to battery pack 14b. This ignites the magnesium-oxide composite (magnesium burns at 650°C), superheating the  
15 liquid CO<sub>2</sub> making a supercritical substance (highly dense gas) at very high pressure. At a pre-determined pressure, e.g. about 1350 bar, the soft metal diaphragm 58 fails. So as not to contaminate the base of launcher 51, the diaphragm 58 has a steel cable connected to it so it stays with the projectile.

A rapid rise in pressure takes place flaring the nylon collar bands to promote a good gas  
20 seal and to prevent a metal-to-bore contact. The projectile 11c is expelled. As projectile 11c leaves the bore of launcher 51, approximately 50% of the supercritical CO<sub>2</sub> has been utilised. The remainder now acts as the propellant, further accelerating the projectile.

The estimated projectile cycle time for launcher 51 is 4 seconds.

25 An ammunition box of approximately twenty projectiles 11c would also hold a spare high output battery pack 14b. One fully charged battery 14b would preferably be sufficient to expel 100 projectiles.

The projectile firing device of the present invention can also be used to launch commercial and military satellites or payloads at low cost into low earth orbit (LEO).  
30 Prior technologies have previously produced a launching system to put satellites into

LEO. One system has launched a probe to an altitude of 180km and another system has not bettered this result.

When a satellite circles close to the earth it is known as low earth orbit (LEO). Satellites in LEO are 320-800km (200-500 miles) high and circle the earth in approximately 90  
5 minutes at a speed of 24, 360kph (17,000mph).

To launch a LEO satellite the projectile needs to attain a velocity of 7920 metres per second (5 miles per second) when leaving the barrel or launch tube. The projectile firing device of the present invention can achieve this by accelerating a projectile in a rapid sequence by employing a number of independent liquid to gas CO<sub>2</sub> chambers in a  
10 chain reaction.

Figures 24-27 depict a satellite-launch device 70 for launching a LEO projectile 79 into a low earth orbit in a sixth embodiment of a projectile firing device of the present invention. Launcher 70 comprises a plurality of modular units 71, typically eight or more such units. In this preferred embodiment, eight modular units each of about eight  
15 metres in length are used. Each unit 71 comprises a CO<sub>2</sub> vessel 72, heating element 73, explosive activated burst disc 74, a smooth barrel bore 75, an electronic projectile location sensor 76 and an electronic control unit (ECU) 77.

Each high pressure CO<sub>2</sub> vessel 72 contains a metered amount of liquid CO<sub>2</sub>. A heating element 73 is incorporated to heat the liquid CO<sub>2</sub> to a pressure in excess of 4000 bar. Its  
20 associated burst disc 74 is attached, sealing the pressure vessel from the bore 75. The burst disc 74 has a fault machined into it; the fault is filled with a shaped high explosive charge to enable an extremely rapid release of the highly dense gasified and super-heated CO<sub>2</sub>.

A bore 75 of each modular unit 71 is smooth to reduce friction. Electronic sensors 76  
25 are located within the launcher bore 75 to detect and monitor a projectile 79 within the launcher 70. The ECU 77 is used monitor and control the launch of a projectile 79.

In use a LEO projectile 79, which in this embodiment is about four metres in length and about one metre in diameter, is placed into breech 80 at one end of launcher 70, and then breech 80 is then sealed. Projectile 79 is carried by a carrier 82, having a plurality  
30 of low friction bands 83. All pressure vessels 72 are then charged with liquid CO<sub>2</sub> with

burst discs 74 in place. The liquid CO<sub>2</sub> is heated until the required pressure is obtained to induce a phase change to “highly dense” gas . The pressure vessel 72 closest to breech 80 is then released which pushes the projectile 79 up the bore at high velocity. The projectile 79 is sensed by sensor(s) 76 in the second adjacent modular unit 71 and  
5 then the second stage is activated releasing CO<sub>2</sub> in the next stage. As projectile 79 is moving through the bore 75 so fast, a very quick response mechanism is required to release the high pressure CO<sub>2</sub>. A C-shaped explosive charge 81 is required to fracture the burst disc 74 and release the CO<sub>2</sub> gas at high volume and high speed. The process is a very rapid deployment of projectile 79 from launcher 70.

10 It should be understood that whilst CO<sub>2</sub> has been selected as the preferable propellant due to its properties and commercial availability, other liquid/gaseous propellants could be used in alternative embodiments.

The term “comprising” as used herein is used in the inclusive sense of “including” or “having” and not in the exclusive sense of “consisting only of”.

## CLAIMS:

1. A projectile firing device comprising:  
an elongate barrel through which a projectile is fired;  
loading means for introducing said projectile into said barrel;  
5 said projectile being adapted to be propelled by a compressed gas propellant,  
characterised in that said compressed gas propellant is initially stored as liquid  
and adapted to be heated by a heating means which induces a phase change such  
that said propellant becomes a highly dense gas.
2. A projectile firing device as claimed in claim 1, wherein said device comprises  
10 at least one chamber for holding said compressed gas propellant, said chamber  
being in fluid communication with said barrel via a valve means adapted to  
release said compressed gas propellant to fire said projectile held in said barrel,  
and a reservoir located remote from said chamber for storing said propellant in  
its initial liquid state, and a means for introducing said propellant in its liquid  
15 state from said reservoir into said chamber.
3. A projectile firing device as claimed in claim 1 or 2, wherein said device is a  
weapon, such as a rifle, gun or pistol.
4. A projectile firing device as claimed in claim 1, wherein said projectile is  
20 housed within a cartridge, said cartridge containing a reservoir of propellant in  
its initial liquid state and a thermal detonator adjacent thereto, said heating  
means adapted to heat said thermal detonator which in turn heats said propellant.
5. A projectile firing device as claimed in claim 4, wherein said device is a  
weapon, such as a grenade launcher.
6. A projectile firing device as claimed in claim 1, wherein said projectile is  
25 housed within a cartridge, said cartridge containing a reservoir of said propellant  
in its initial liquid state and said heating means adapted to heat said propellant is  
integral with said cartridge.



7. A projectile firing device as claimed in claim 6, wherein said cartridge uses a portion of the explosive energy of said propellant to continue acceleration of the projectile for a period of time after the projectile has left said device.
8. A projectile firing device as claimed in claim 7, wherein said device is a  
5 weapon, such as a mortar launcher.
9. A projectile firing device as claimed in claim 1 or 2, wherein said device is a satellite launching device and said projectile is a low earth orbit satellite.
10. A projectile firing device as claimed in claim 9, wherein said device comprises a plurality of modular units and a plurality of chambers.
- 10 11. A projectile firing device as claimed in claim 10, where in each chamber is associated with a respective modular unit.
12. A projectile firing device as claimed in claim 3, wherein said barrel of said device is made of a composite material.
13. A projectile firing device as claimed in claim 12, wherein said composite  
15 material is a kevlar/aluminate laminate.
14. A projectile firing device as claimed in claim 12, wherein said barrel has a teflon coated bore.
15. A projectile firing device as claimed in claim 3, wherein said device is a rifle and it has a body, stock and pistol grip made of plastic.
- 20 16. A projectile firing device as claimed in claim 15, wherein said plastic is glass filled nylon.
17. A projectile firing device as claimed in claim 1, wherein said device further comprises an electronic control unit, which controls the ingress of said propellant in its liquid state from the reservoir to said chamber and controls the  
25 heating means used to heat said propellant.
18. A projectile firing device as claimed in claim 17, further comprising targeting means for targeting said projectile and said electronic control unit is operably

connected to said targeting means to control ingress of said propellant to said chamber and to control the heating means used to heat said propellant in response to varying targeting parameters, such as distance and attitude of the device.

5 19. A projectile firing device comprising:

an elongate barrel through which a projectile is fired;

loading means for introducing said projectile into said barrel;

at least one chamber for holding a compressed gas propellant, said chamber  
being in fluid communication with said barrel via a valve means being adapted  
10 to release said compressed gas propellant to fire a projectile held in said barrel;

characterised in that said compressed gas propellant is initially a liquid stored in  
a reservoir remote from said chamber, said propellant in its liquid form being  
adapted to be introduced into said chamber and heated therein by a heating  
means that induces a phase change in the propellant from a liquid to a highly  
15 dense gas.

20. A projectile firing device as defined in any one of claims 1 to 19, wherein said propellant is carbon dioxide.

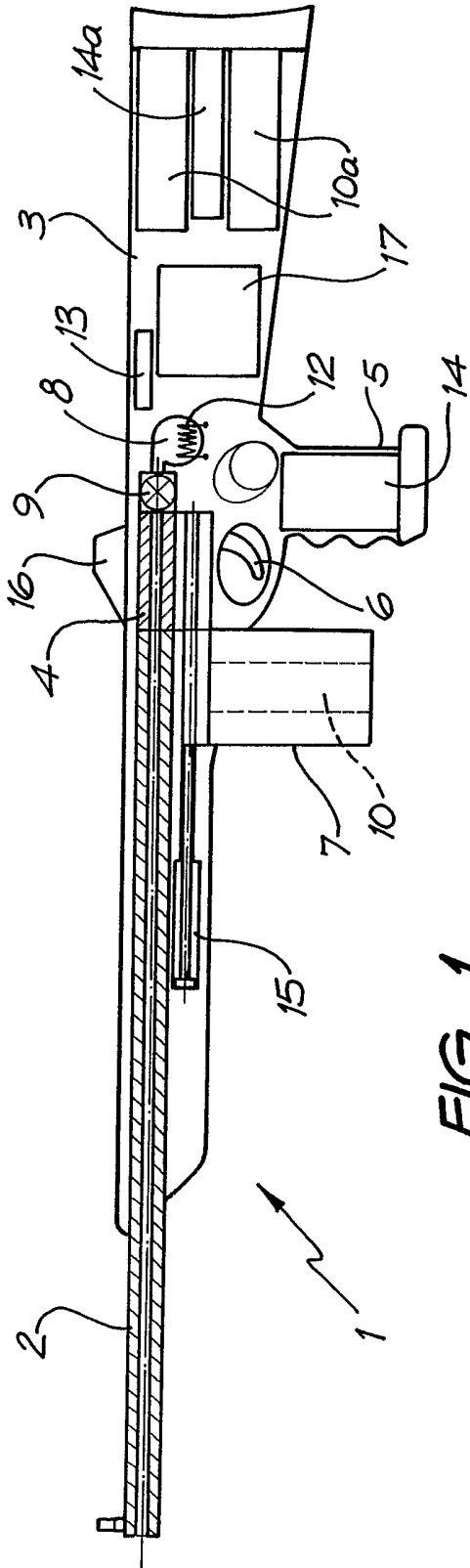

FIG. 1

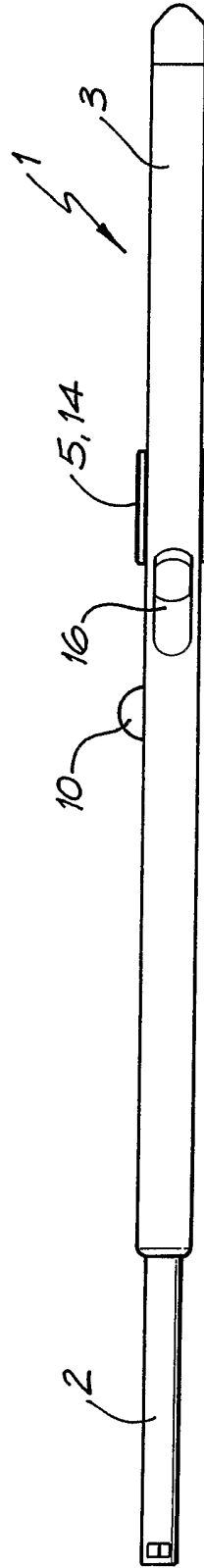

FIG. 2

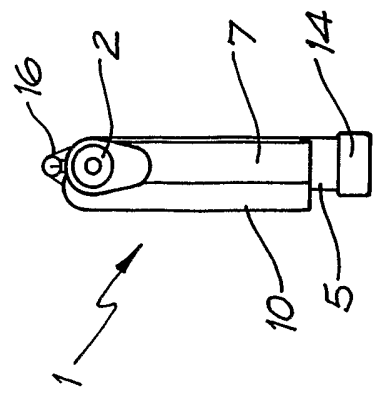

FIG. 3

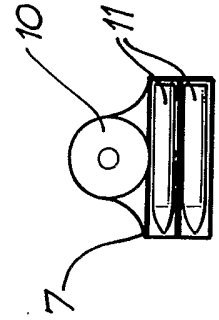

FIG. 4

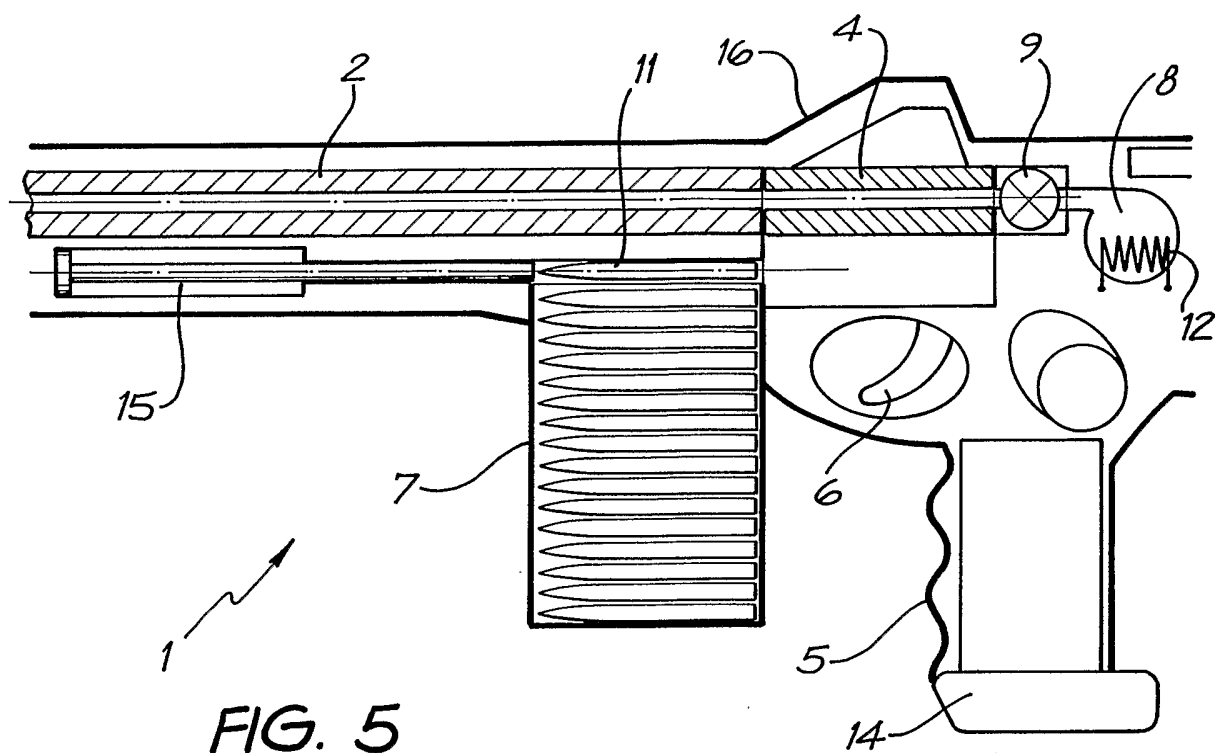

FIG. 5

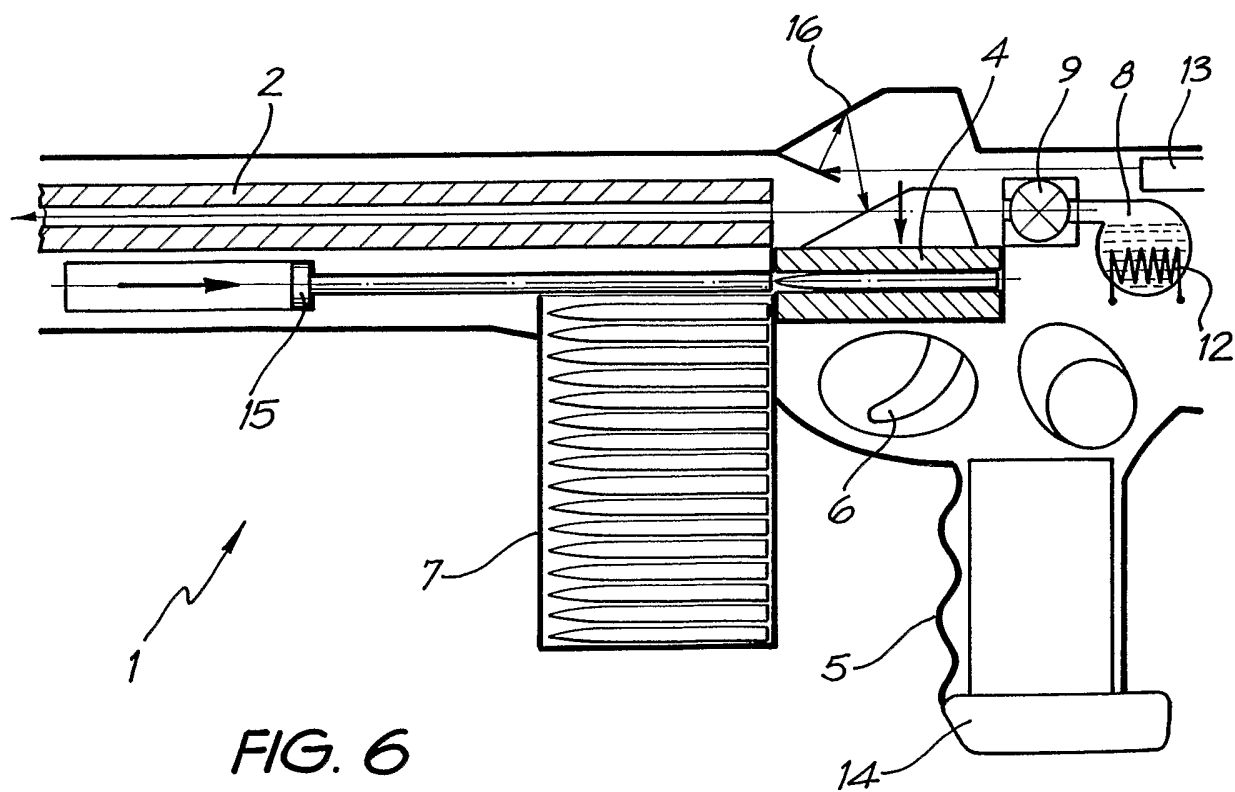

FIG. 6

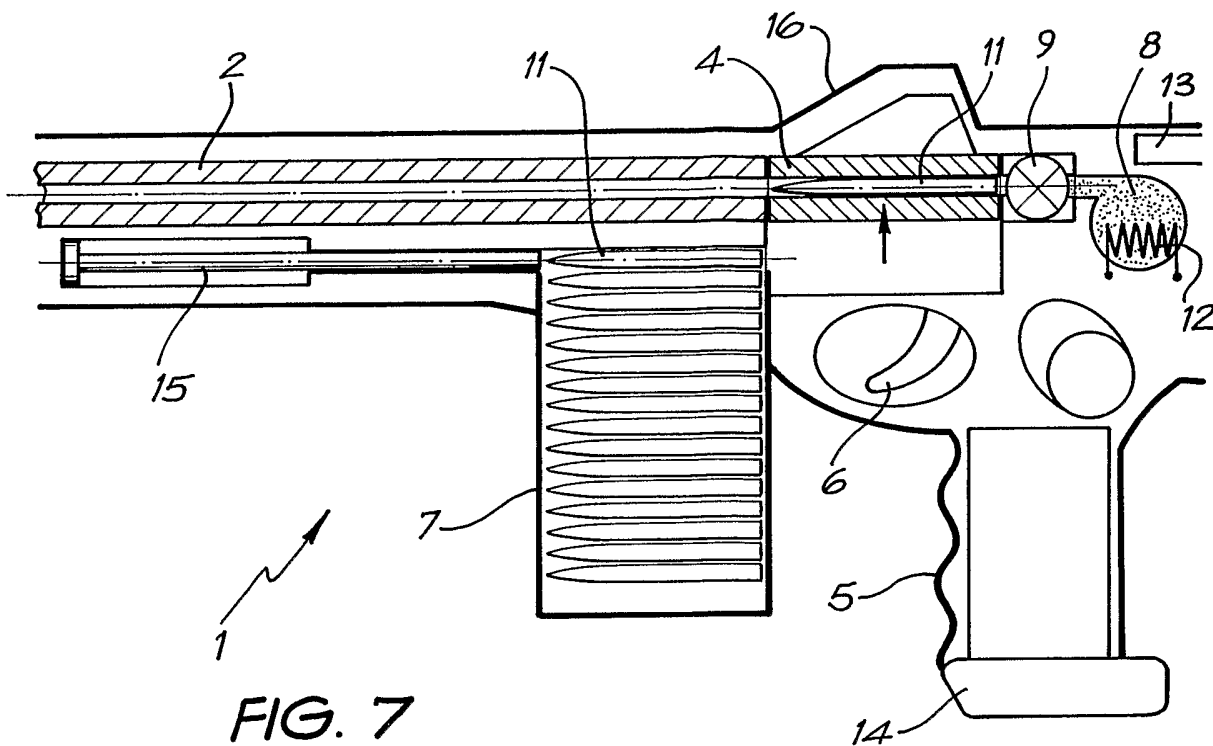

FIG. 7

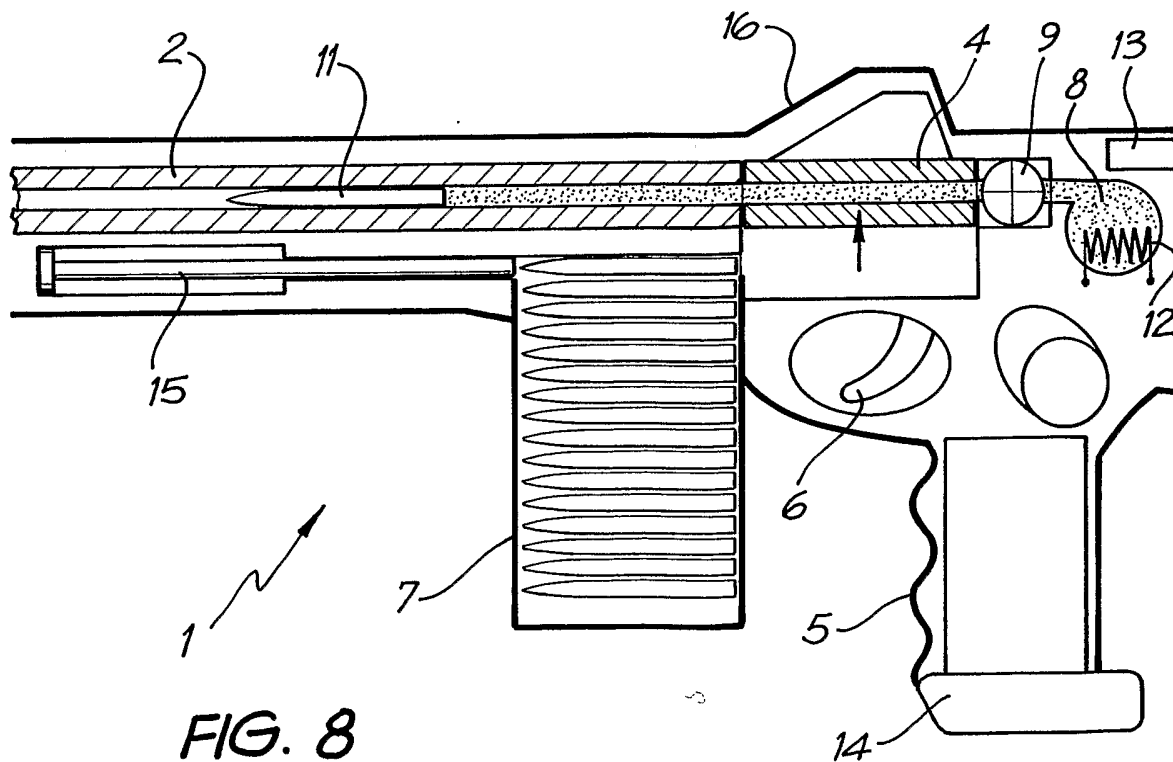
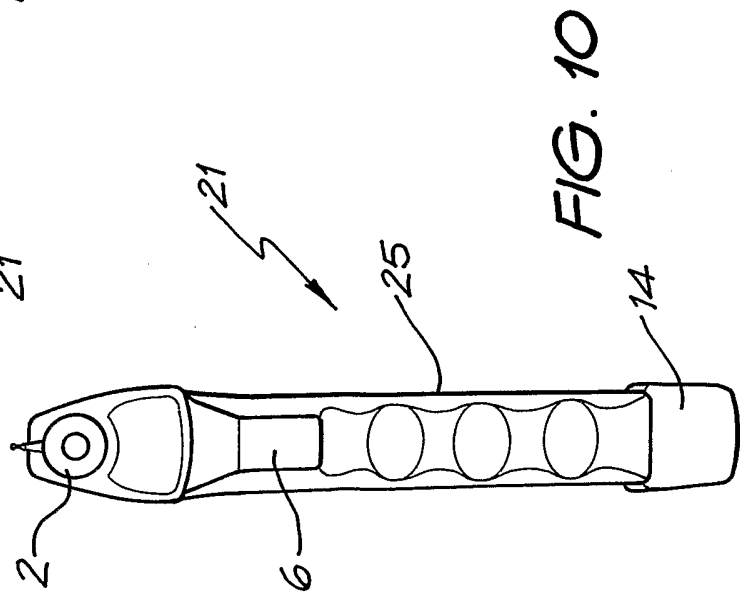
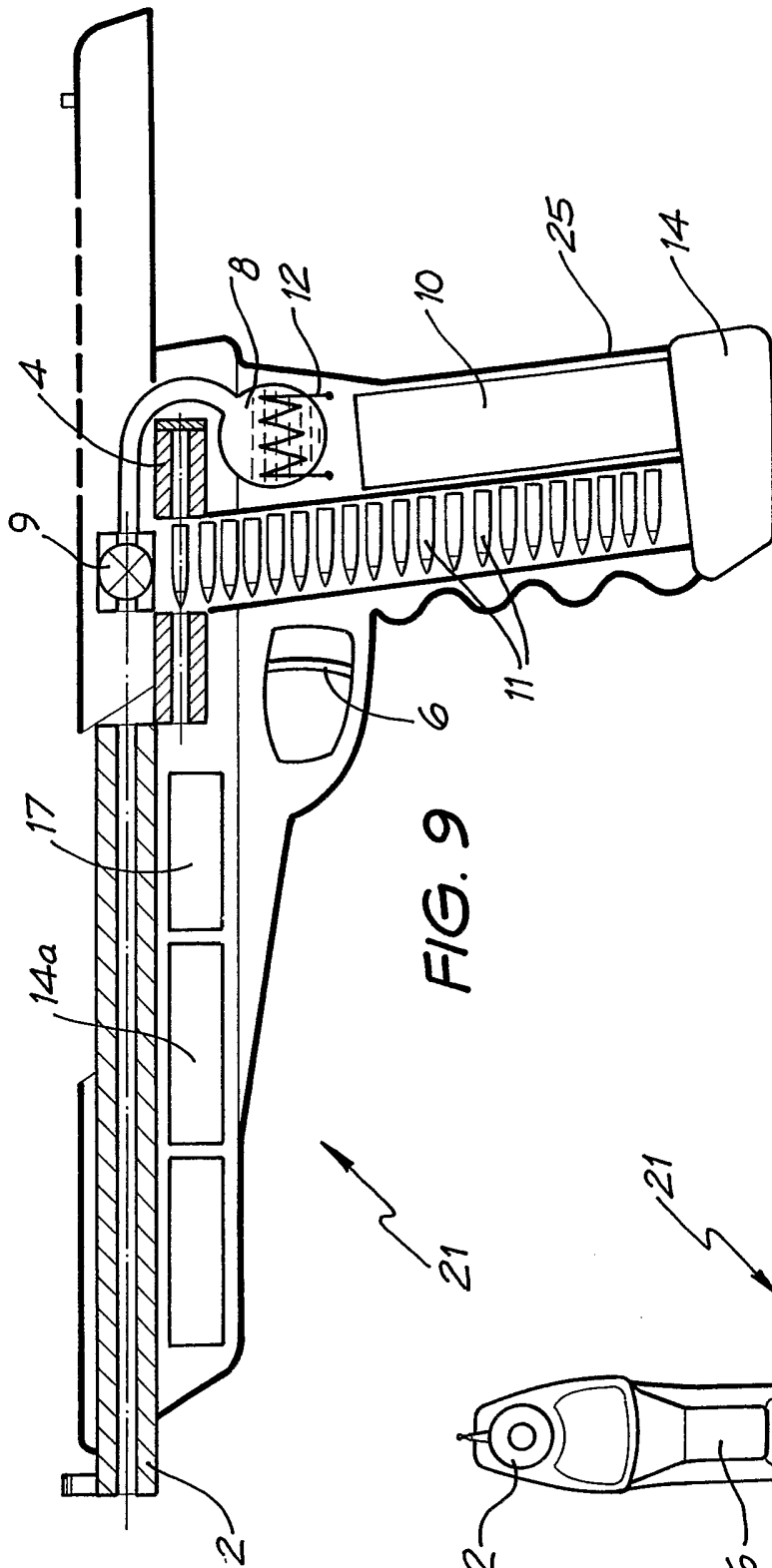

FIG. 8



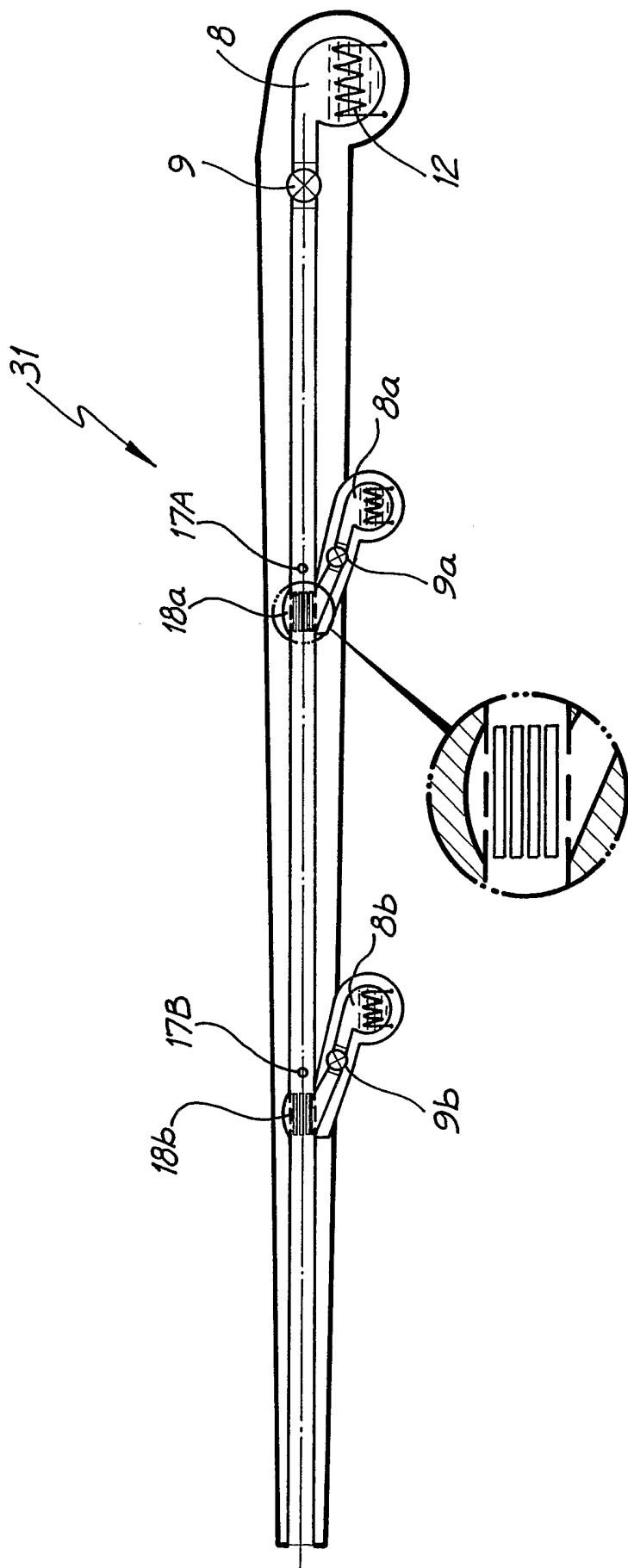
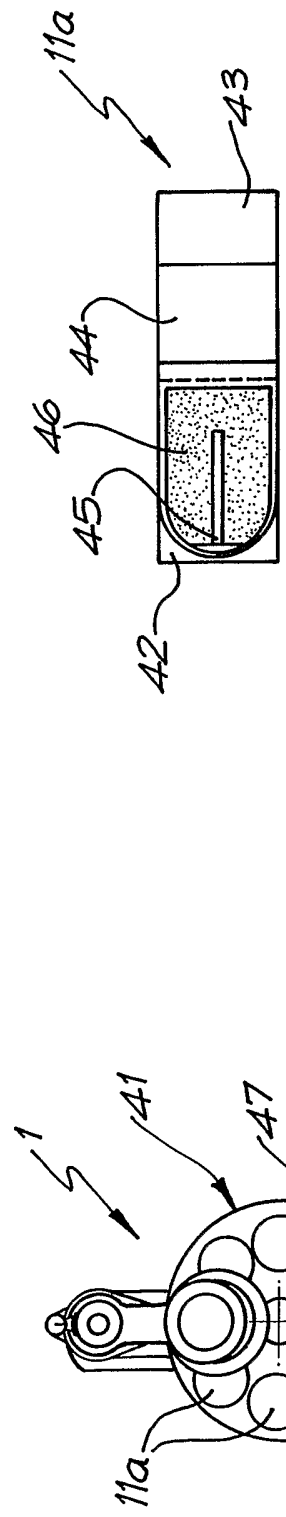
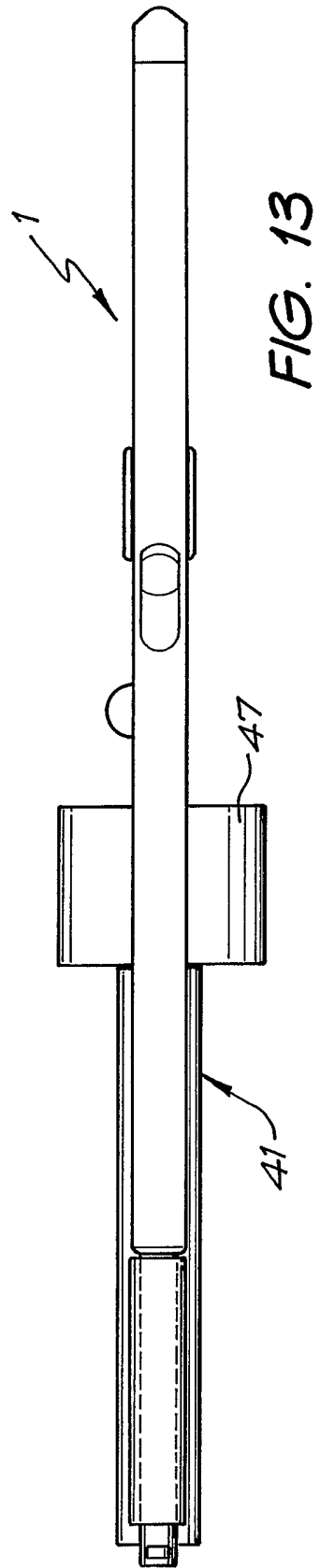
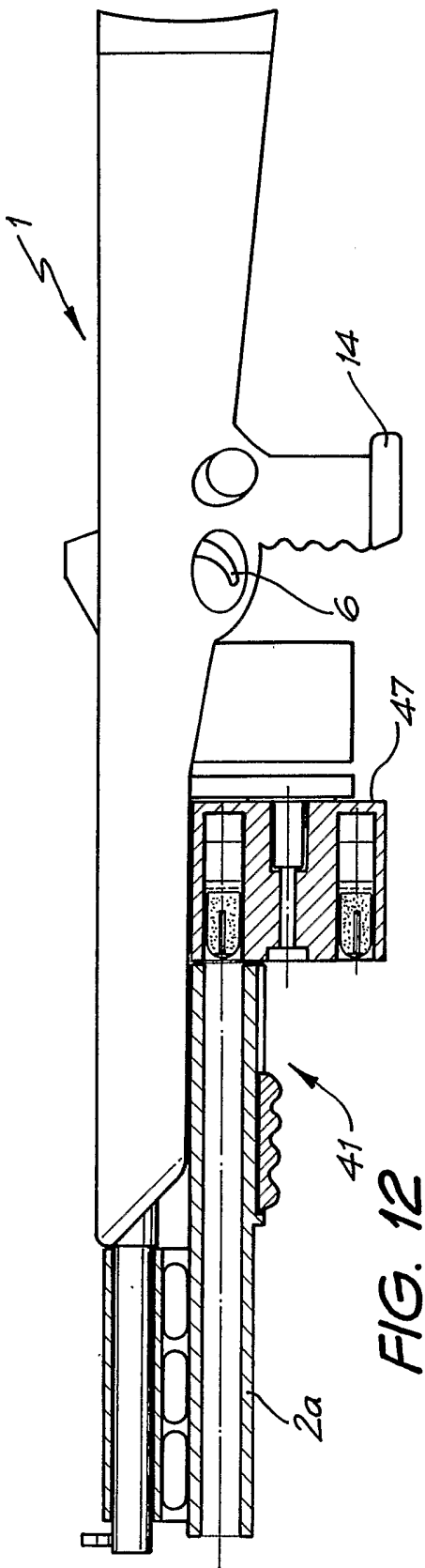

FIG. 11





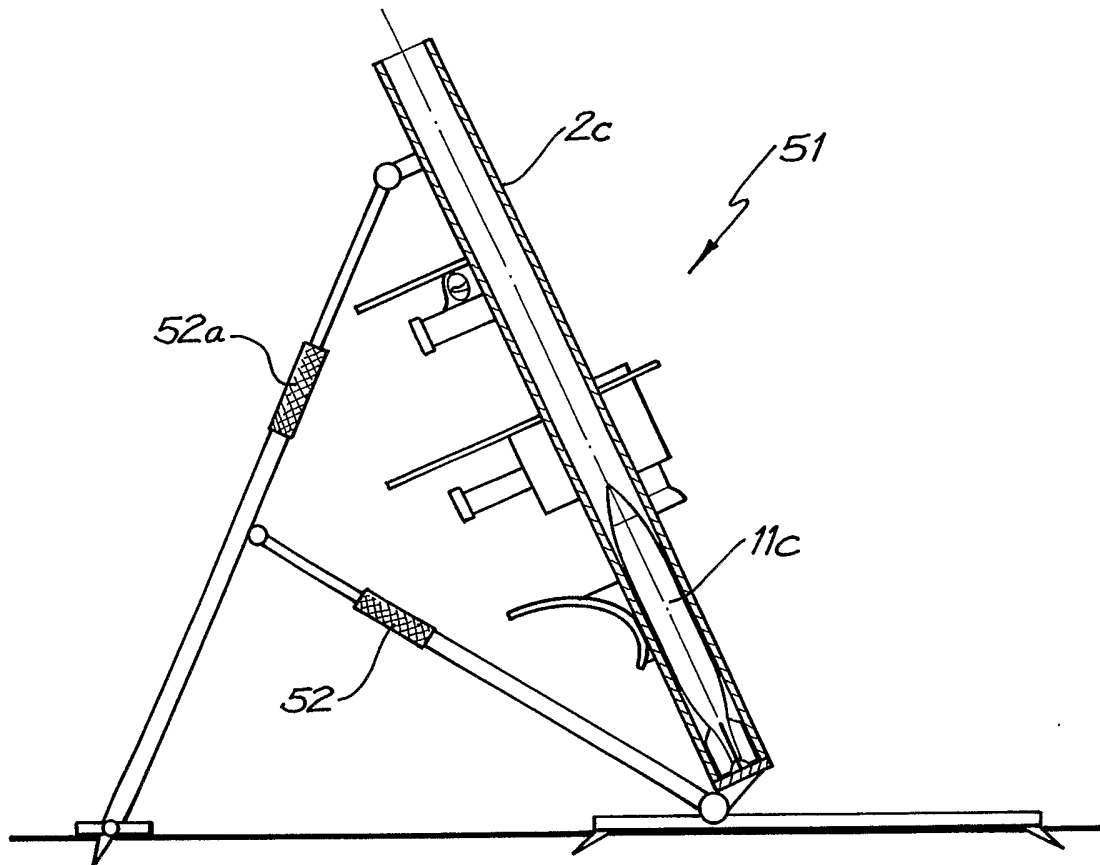

FIG. 16

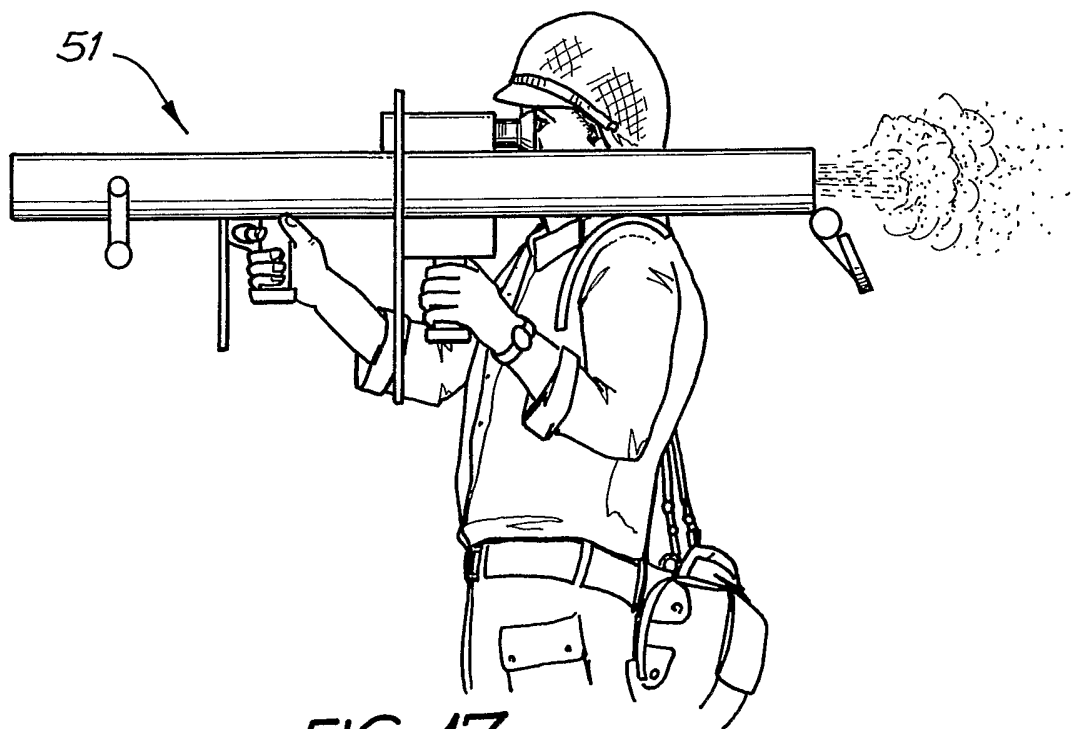

FIG. 17

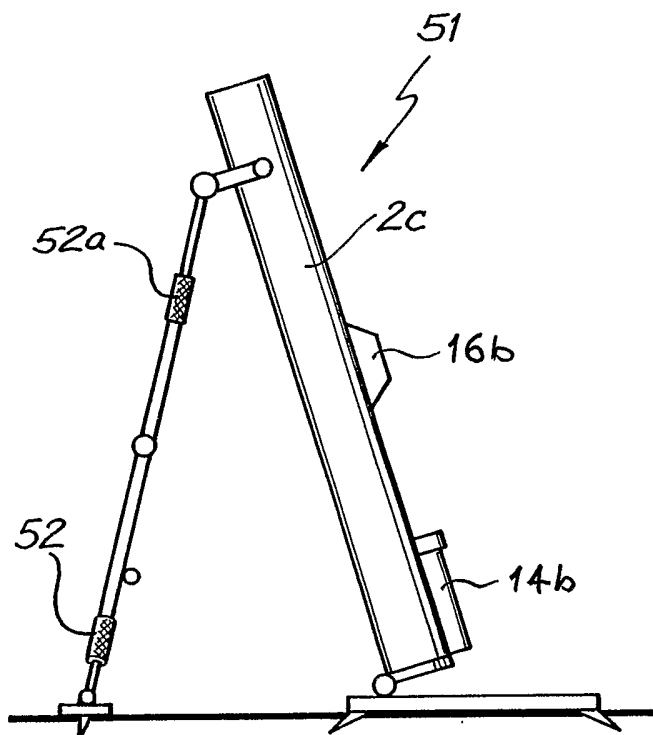

FIG. 18

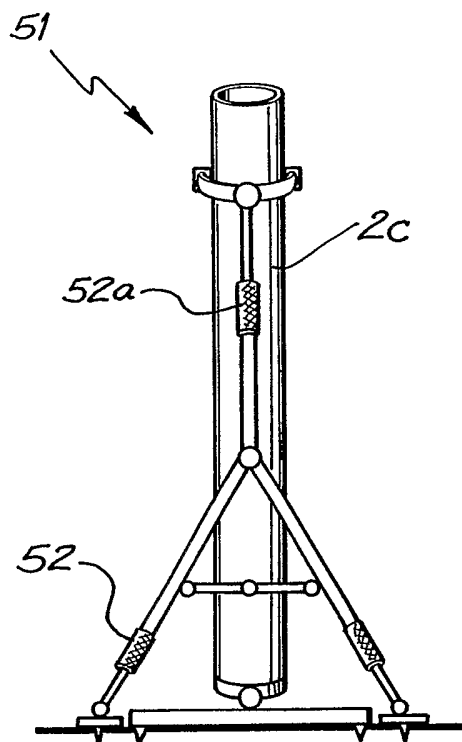

FIG. 19

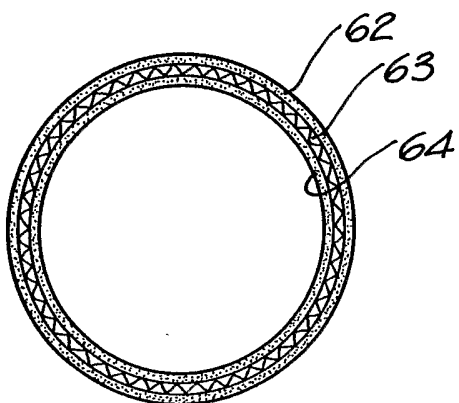

FIG. 20

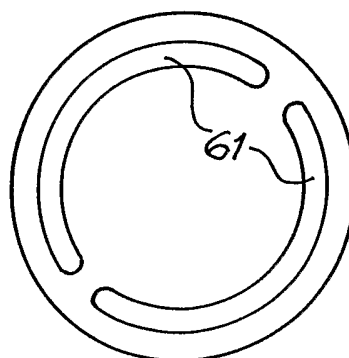

FIG. 21

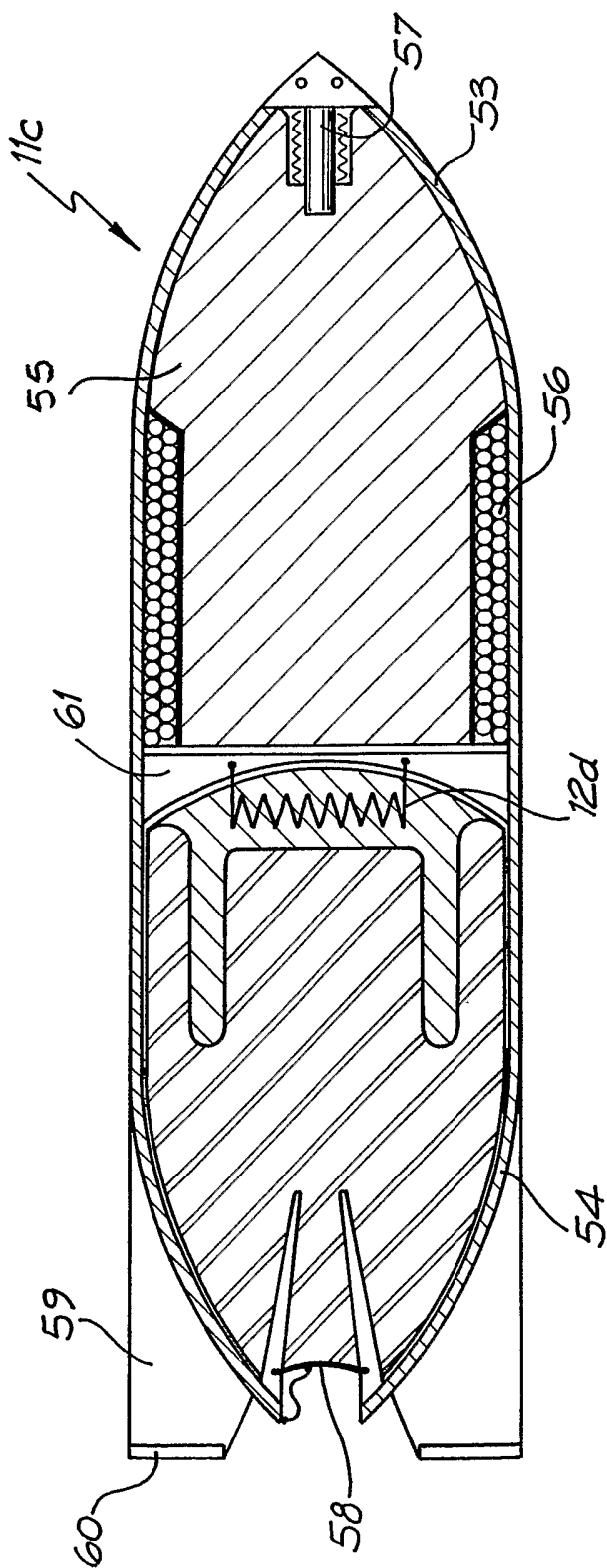

FIG. 22

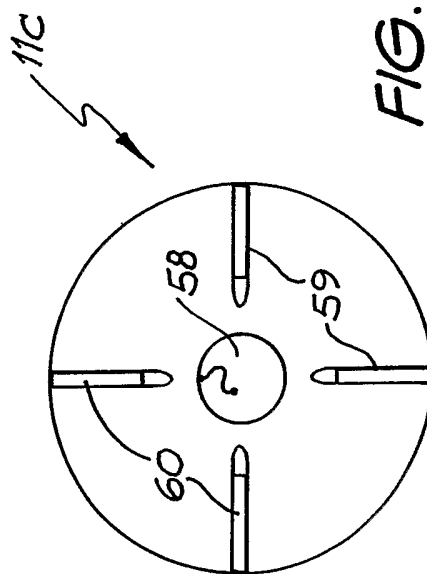

FIG. 23

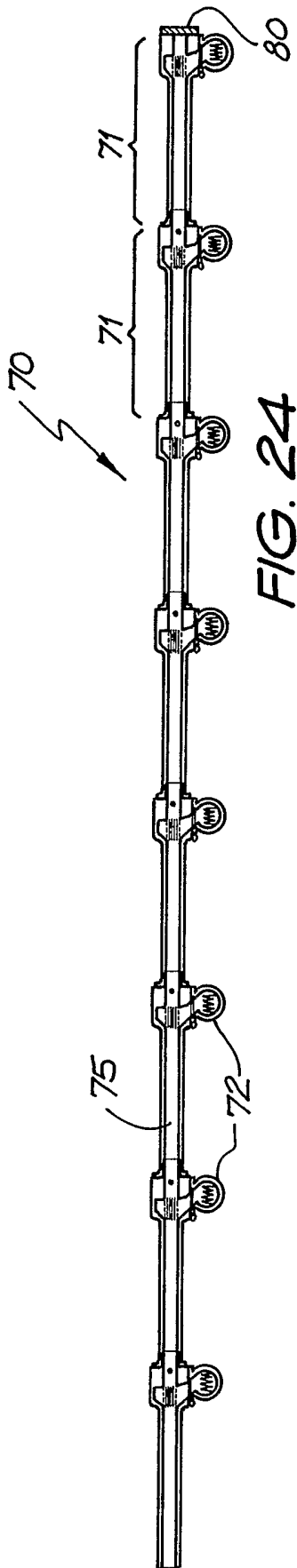

FIG. 24

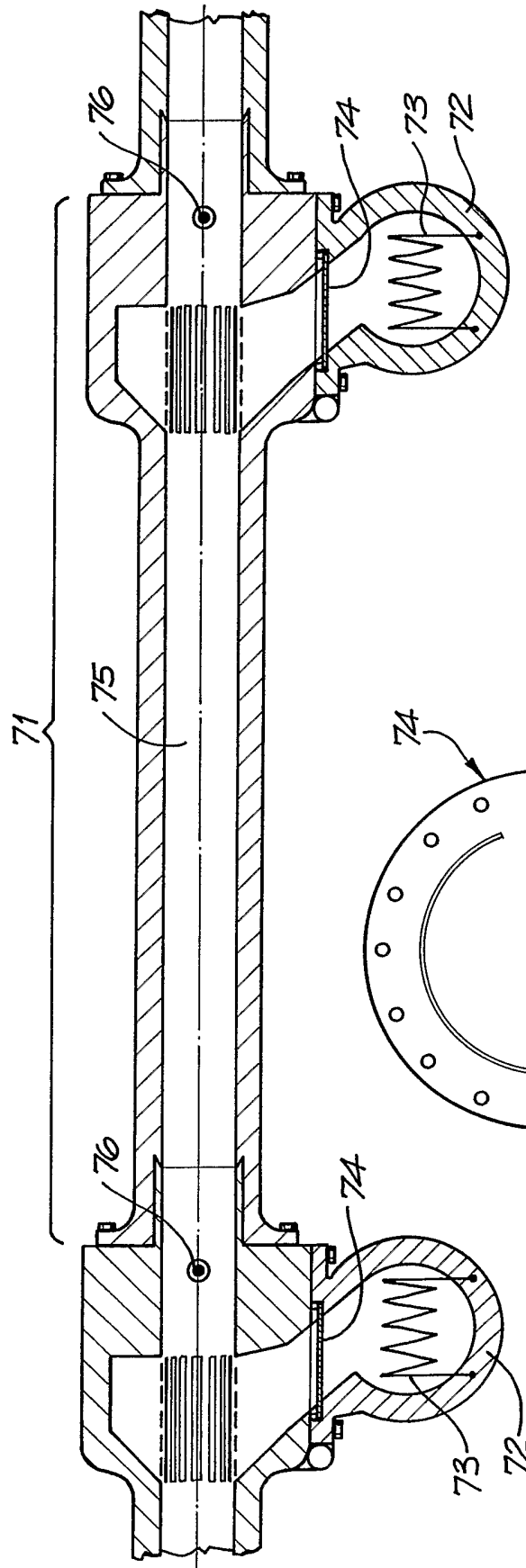

FIG. 25

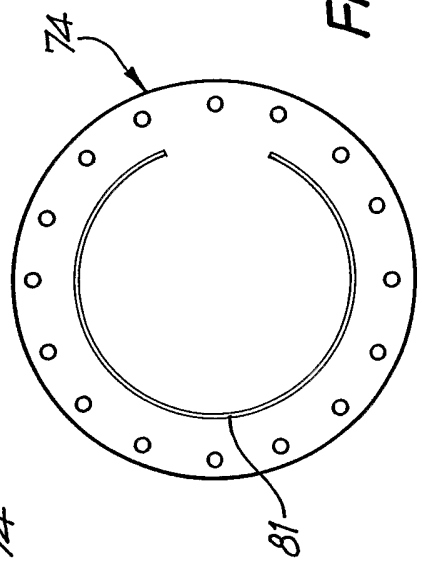

FIG. 26

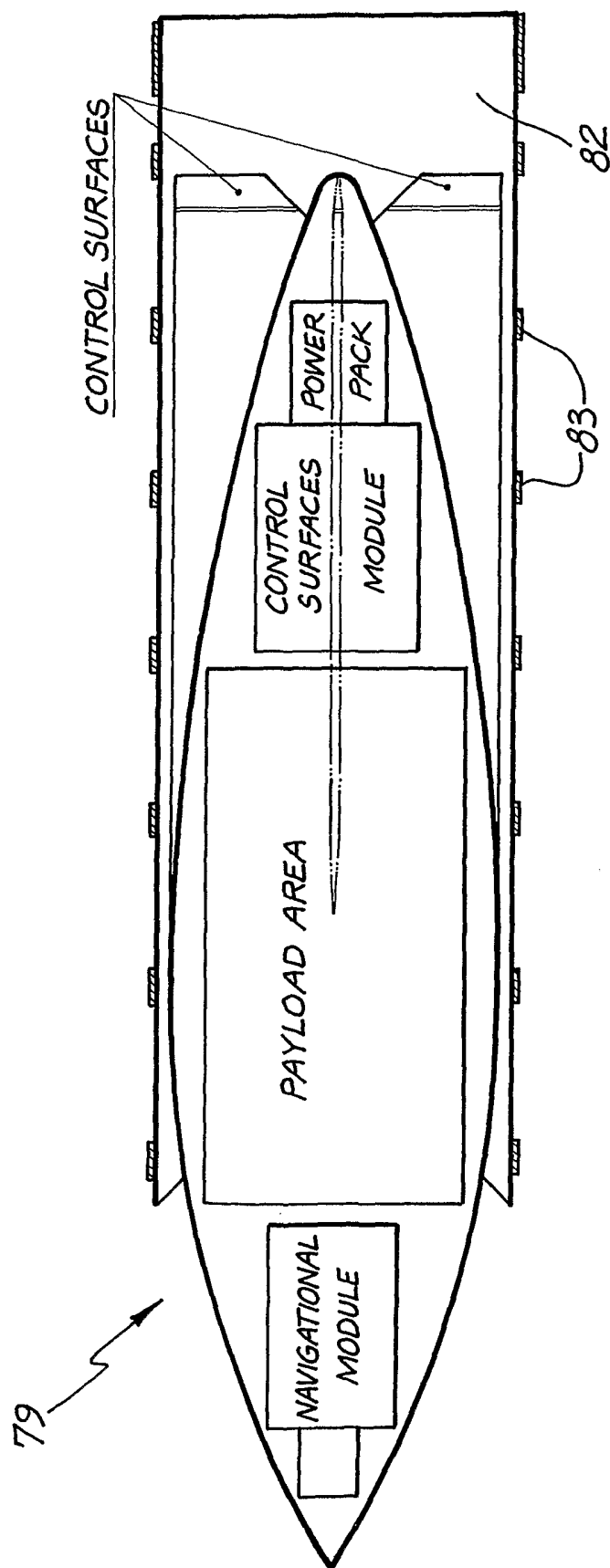

FIG. 27

## INTERNATIONAL SEARCH REPORT

International application No.  
PCT/AU02/01492

|  |  |                       |  |   |   |  |   |  |  |   |  |  |
|--|--|-----------------------|--|---|---|--|---|--|--|---|--|--|
| <b>A. CLASSIFICATION OF SUBJECT MATTER</b>   |  |                       |  |   |   |  |   |  |  |   |  |  |
| Int. Cl. <sup>7</sup> : F41B 11/06; F42B 6/00, 30/04, 30/10; B64G 1/10; F41A 21/02   |  |                       |  |   |   |  |   |  |  |   |  |  |
| According to International Patent Classification (IPC) or to both national classification and IPC  |  |                       |  |   |   |  |   |  |  |   |  |  |
| <b>B. FIELDS SEARCHED</b>  |  |                       |  |   |   |  |   |  |  |   |  |  |
| Minimum documentation searched (classification system followed by classification symbols)  |  |                       |  |   |   |  |   |  |  |   |  |  |
| Documentation searched other than minimum documentation to the extent that such documents are included in the fields searched  |  |                       |  |   |   |  |   |  |  |   |  |  |
| AU: IPC F41B 11/00, 11/06; F42B 6/00, 30/04, 30/10; B64G 1/10; F41A 21/02  |  |                       |  |   |   |  |   |  |  |   |  |  |
| Electronic data base consulted during the international search (name of data base and, where practicable, search terms used)   |  |                       |  |   |   |  |   |  |  |   |  |  |
| DWPI: Q79/DC with keywords such as compressed, liquid, gas and similar terms.  |  |                       |  |   |   |  |   |  |  |   |  |  |
| <b>C. DOCUMENTS CONSIDERED TO BE RELEVANT</b>  |  |                       |  |   |   |  |   |  |  |   |  |  |
| Category*  | Citation of document, with indication, where appropriate, of the relevant passages   | Relevant to claim No. |  |   |   |  |   |  |  |   |  |  |
| A  | US 5462042 A (GREENWELL) 31 October 1995   |                       |  |   |   |  |   |  |  |   |  |  |
| A  | DE 3733240 A (STEYR-DAIMLER-PUCH AG) 14 April 1988   |                       |  |   |   |  |   |  |  |   |  |  |
| A  | US 5497758 A (DOBBINS et al) 12 March 1996   |                       |  |   |   |  |   |  |  |   |  |  |
| A  | WO 87/07940 A (COMMISSARIAT A L'ENERGIE ATOMIQUE) 30 December 1987   |                       |  |   |   |  |   |  |  |   |  |  |
| <input type="checkbox"/> Further documents are listed in the continuation of Box C <input checked="" type="checkbox"/> See patent family annex   |  |                       |  |   |   |  |   |  |  |   |  |  |
| <p>* Special categories of cited documents:</p> <table border="0"> <tr> <td>"A" document defining the general state of the art which is not considered to be of particular relevance</td> <td>"T" later document published after the international filing date or priority date and not in conflict with the application but cited to understand the principle or theory underlying the invention</td> </tr> <tr> <td>"E" earlier application or patent but published on or after the international filing date</td> <td>"X" document of particular relevance; the claimed invention cannot be considered novel or cannot be considered to involve an inventive step when the document is taken alone</td> </tr> <tr> <td>"L" document which may throw doubts on priority claim(s) or which is cited to establish the publication date of another citation or other special reason (as specified)</td> <td>"Y" document of particular relevance; the claimed invention cannot be considered to involve an inventive step when the document is combined with one or more other such documents, such combination being obvious to a person skilled in the art</td> </tr> <tr> <td>"O" document referring to an oral disclosure, use, exhibition or other means</td> <td>"&amp;" document member of the same patent family</td> </tr> <tr> <td>"P" document published prior to the international filing date but later than the priority date claimed</td> <td></td> </tr> </table> |  |                       | "A" document defining the general state of the art which is not considered to be of particular relevance | "T" later document published after the international filing date or priority date and not in conflict with the application but cited to understand the principle or theory underlying the invention | "E" earlier application or patent but published on or after the international filing date | "X" document of particular relevance; the claimed invention cannot be considered novel or cannot be considered to involve an inventive step when the document is taken alone | "L" document which may throw doubts on priority claim(s) or which is cited to establish the publication date of another citation or other special reason (as specified) | "Y" document of particular relevance; the claimed invention cannot be considered to involve an inventive step when the document is combined with one or more other such documents, such combination being obvious to a person skilled in the art | "O" document referring to an oral disclosure, use, exhibition or other means | "&" document member of the same patent family | "P" document published prior to the international filing date but later than the priority date claimed |  |
| "A" document defining the general state of the art which is not considered to be of particular relevance   | "T" later document published after the international filing date or priority date and not in conflict with the application but cited to understand the principle or theory underlying the invention  |                       |  |   |   |  |   |  |  |   |  |  |
| "E" earlier application or patent but published on or after the international filing date  | "X" document of particular relevance; the claimed invention cannot be considered novel or cannot be considered to involve an inventive step when the document is taken alone   |                       |  |   |   |  |   |  |  |   |  |  |
| "L" document which may throw doubts on priority claim(s) or which is cited to establish the publication date of another citation or other special reason (as specified)  | "Y" document of particular relevance; the claimed invention cannot be considered to involve an inventive step when the document is combined with one or more other such documents, such combination being obvious to a person skilled in the art |                       |  |   |   |  |   |  |  |   |  |  |
| "O" document referring to an oral disclosure, use, exhibition or other means   | "&" document member of the same patent family  |                       |  |   |   |  |   |  |  |   |  |  |
| "P" document published prior to the international filing date but later than the priority date claimed   |  |                       |  |   |   |  |   |  |  |   |  |  |
| Date of the actual completion of the international search<br>22 November 2002  | Date of mailing of the international search report<br>27 NOV 2002  |                       |  |   |   |  |   |  |  |   |  |  |
| Name and mailing address of the ISA/AU<br>AUSTRALIAN PATENT OFFICE<br>PO BOX 200, WODEN ACT 2606, AUSTRALIA<br>E-mail address: pct@ipaustalia.gov.au<br>Facsimile No. (02) 6285 3929   | Authorized officer<br><br><b>JEFFREY CARL</b><br>Telephone No : (02) 6283 2543   |                       |  |   |   |  |   |  |  |   |  |  |

# INTERNATIONAL SEARCH REPORT

Information on patent family members

International application No.

**PCT/AU02/01492**

This Annex lists the known "A" publication level patent family members relating to the patent documents cited in the above-mentioned international search report. The Australian Patent Office is in no way liable for these particulars which are merely given for the purpose of information.

| Patent Document Cited in Search Report |          | Patent Family Member |         |    |        |    |         |
|--|----------|----------------------|---------|----|--------|----|---------|
| US                                     | 5462042  | NONE                 |         |    |        |    |         |
| DE                                     | 3733240  | AT                   | 2611/86 |    |        |    |         |
| US                                     | 5497758  | NONE                 |         |    |        |    |         |
| WO                                     | 87/07940 | CA                   | 1316422 | EP | 251864 | FR | 2600344 |
| END OF ANNEX                           |          |                      |         |    |        |    |         |