

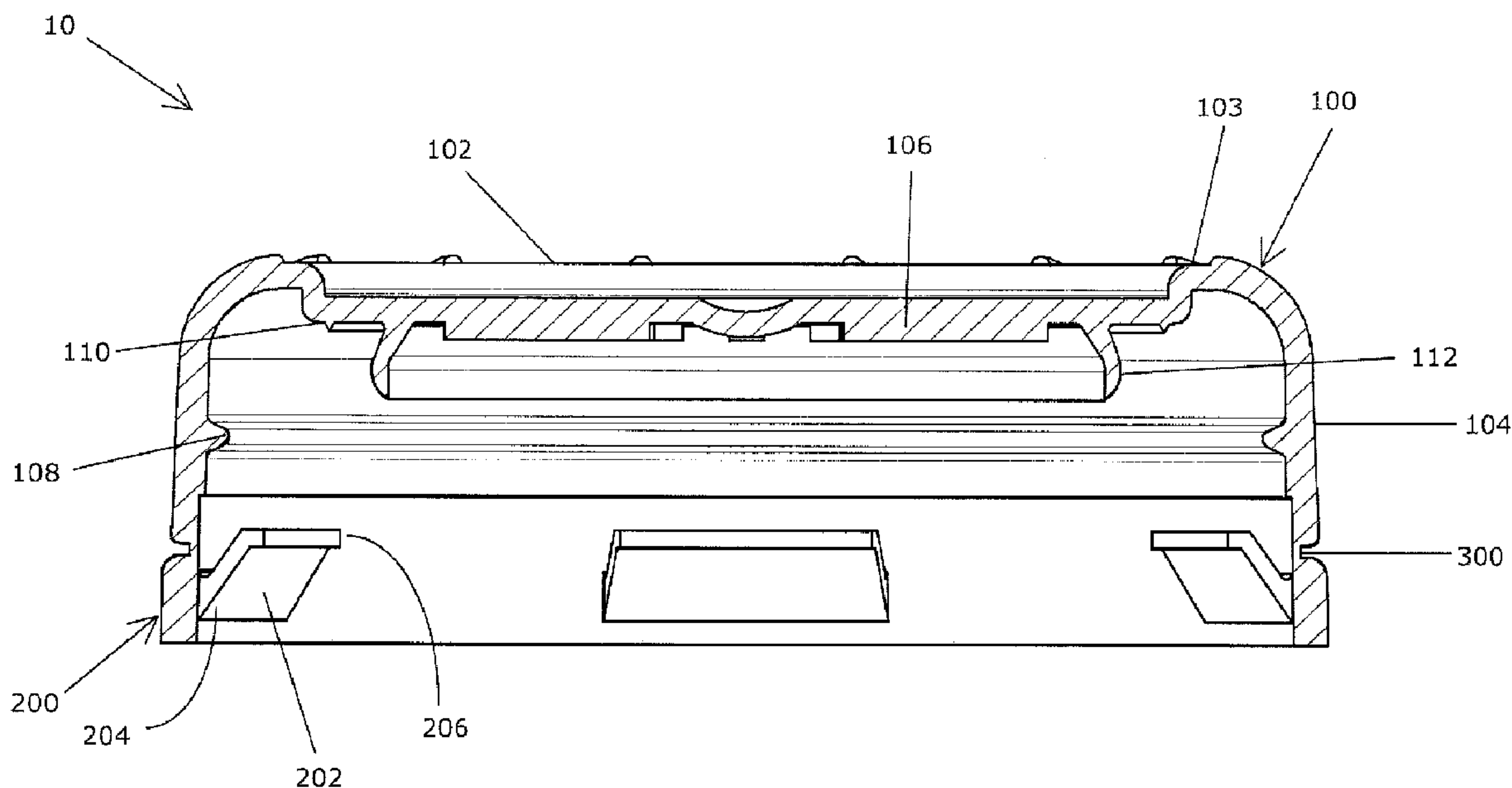

(86) Date de dépôt PCT/PCT Filing Date: 2014/12/12
 (87) Date publication PCT/PCT Publication Date: 2015/07/07
 (45) Date de délivrance/Issue Date: 2016/11/15
 (85) Entrée phase nationale/National Entry: 2015/04/24
 (86) N° demande PCT/PCT Application No.: CA 2014/051208
 (87) N° publication PCT/PCT Publication No.: 2016/041053
 (30) Priorité/Priority: 2014/09/19 (US62/052,616)

(51) Cl.Int./Int.Cl. *B65D 55/02* (2006.01)
 (72) Inventeur/Inventor:
 WITT, STEVEN HUGH, CA
 (73) Propriétaire/Owner:
 STANPAC INC., CA
 (74) Agent: RIDOUT & MAYBEE LLP

(54) Titre : DISPOSITIF DE FERMETURE INVOLABLE ET SA METHODE DE FABRICATION
 (54) Title: TAMPER EVIDENT CLOSURE AND METHOD OF MAKING SAME



(57) **Abrégé/Abstract:**

A one piece molded tamper evident push-on closure suitable for closing an opening of a bottle, and method for manufacture thereof. The closure includes a cap portion, a latch ring portion and a frangible connector connecting the cap portion and the latch ring portion. The closure includes a plurality of resiliently deformable teeth extending inwardly from the latch ring portion and towards the cap portion for engaging the latch ring portion onto the neck of the bottle. The closure includes a manually engageable tab projecting from the latch ring portion to permit application of a manual force to rupture the frangible connector and permit the cap portion to be at least partially disconnected from the latch ring portion.

ABSTRACT

A one piece molded tamper evident push-on closure suitable for closing an opening of a bottle, and method for manufacture thereof. The closure includes a cap portion, a latch ring portion and a frangible connector
5 connecting the cap portion and the latch ring portion. The closure includes a plurality of resiliently deformable teeth extending inwardly from the latch ring portion and towards the cap portion for engaging the latch ring portion onto the neck of the bottle. The closure includes a manually engageable tab
10 projecting from the latch ring portion to permit application of a manual force to rupture the frangible connector and permit the cap portion to be at least partially disconnected from the latch ring portion.

TAMPER EVIDENT CLOSURE AND METHOD OF MAKING SAME**FIELD**

[0001] The present disclosure relates to tamper evident closures and
5 methods of making such closures. In particular, the present disclosure may be
relevant to snap-on closures suitable for use with re-usable containers, such as
glass milk bottles.

BACKGROUND

[0002] Tamper evident closures are typically fitted over container openings by
10 the manufacturer, and provide visual indication to the consumer if the closure has
been opened or otherwise tampered with. Typically, tamper evident closures have a
feature that must be dislocated or ruptured in order to open the closure (e.g., a
seal that must be broken), and once dislocated or ruptured cannot be returned to
its initial state, thus clearly indicating the closure has been opened. Examples of
15 such lids include U.S. Patent No. 5,875,908 and U.S. Patent No. 6,341,707.

[0003] Such closures often have teeth that engage with the container and
prevents opening of the closure unless the tamper evident feature is dislocated or
ruptured. The teeth should be able to sufficiently engage with the container and
should be sufficiently robust to prevent opening of the closure without dislocating or
20 rupturing the tamper evident feature. However, limitations in the manufacturing
process and/or the process of fitting the closure over the container opening may
result in the teeth being insufficiently engaged with the container and/or
insufficiently robust.

- 2 -

[0004] In the case of snap-on closures, it may also be desirable to ensure that the closure can provide a liquid-tight seal similar to that provided by screw-on closures.

SUMMARY

5 **[0005]** In some example embodiments, the present disclosure provides a one piece molded tamper evident push-on closure suitable for closing an opening of a bottle, comprising: a cap portion comprising a sidewall and an top wall; a plurality of engageable protrusions on an inner surface of the top wall of the cap portion for enabling rotation of the closure during molding; a latch ring portion; a plurality of
10 resiliently deformable teeth extending inwardly from the latch ring portion and towards the cap portion for engaging the latch ring portion onto the neck of the bottle, each tooth being connected to the latch ring portion at a proximal end and having a reinforced distal end; a frangible connector connecting the cap portion and the latch ring portion; and a manually engageable tab projecting from the latch ring
15 portion to permit application of a manual force to rupture the frangible connector and permit the cap portion to be at least partially disconnected from the latch ring portion.

[0006] In some example embodiments, the present disclosure provides a method for manufacturing a one piece molded tamper evident push-on closure, the
20 method comprising: injecting a polymer into a mold to mold the closure, the mold including mold cavities to mold protruding teeth of the closure; engaging protrusions on the molded closure and rotating the closure within the mold, the closure being rotated to a release position in which the protruding teeth of the closure are freed from the corresponding mold cavities; and releasing the molded
25 closure from the mold.

[0007] In some example embodiments, the present disclosure provides a one piece molded tamper evident push-on closure suitable for closing an opening of a bottle, comprising: a cap portion comprising a sidewall and an top wall; a first continuous annular ridge protruding inwardly from the top wall of the cap portion
30 for engaging the opening of the bottle; a second continuous ridge protruding

- 3 -

inwardly from the sidewall of the cap portion for engaging a neck of the bottle; a latch ring portion; a plurality of resiliently deformable teeth extending inwardly from the latch ring portion and towards the cap portion for engaging the latch ring portion onto the neck of the bottle; a frangible connector connecting the cap portion and the latch ring portion; and a manually engageable tab projecting from the latch ring portion to permit application of a manual force to rupture the frangible connector and permit the cap portion to be at least partially disconnected from the latch ring portion.

10 **BRIEF DESCRIPTION OF THE DRAWINGS**

[0008] Reference will now be made, by way of example, to the accompanying drawings which show example embodiments of the present application, and in which:

15 **[0009]** FIG. 1 is a perspective view of an example closure in accordance with the present disclosure;

[0010] FIG. 2 is a plan view of the top of the example closure of FIG. 1;

[0011] FIG. 3 is a plan view of the bottom of the example closure of FIG. 1;

[0012] FIG. 4 is a cross-sectional view of the example closure of FIG. 1, across line A-A of FIG. 2;

20 **[0013]** FIG. 5 is a plan view of a side of the example closure of FIG. 1;

[0014] FIG. 6 is a plan view of another side of the example closure of FIG. 1; and

[0015] FIG. 7 is a flowchart illustrating an example method for manufacturing a closure in accordance with the present disclosure.

25 **[0016]** Similar reference numerals may have been used in different figures to denote similar components.

DESCRIPTION OF EXAMPLE EMBODIMENTS

[0017] Reference is made to FIGS. 1-6, showing an example closure 10 in accordance with the present disclosure. The closure 10 may be a snap-on closure such as a snap-on cap, and may be suitable for use to close an opening of a bottle such as a glass or plastic bottle (e.g., a glass milk bottle). The closure 10 may be manufactured using a one-piece molding process, as described further below.

[0018] The closure 10 may include a cap portion 100 and a latch ring portion 200. The cap portion 100 and the latch ring portion 200 may be interconnected by way of a frangible connector 300. The frangible connector 300 may be configured to be easily tearable using manual force, to separate the cap portion and the latch ring portion 200. The frangible connector 300 may comprise a plurality of frangible tabs with spacing therebetween, or may comprise a section of tearable material (e.g., a thinner section of material compared to the cap portion 100 and the latch ring portion 200), for example.

[0019] The cap portion 100 may include an top wall 102 and a side wall 104 extending about the periphery 103 of the top wall 102. The top wall 102 may be substantially planar, as shown in the example drawings, or may be domed, for example. The side wall 104 may be textured on its outer surface (e.g., with evenly-spaced raised ridges 105, as in the example drawings) to facilitate manual gripping and removal of the cap portion 100. The closure 10 may be dimensioned to fit over the opening of a standard glass milk bottle. For example, the closure 10 may be approximately circular or cylindrical in shape, with a diameter in the range of about 1.5"-2.5", preferably about 2", and a height in the range of about 0.50"-0.75", preferably about 0.65"-0.70". Other geometries and dimensions may be suitable, depending on the opening to be closed.

- 5 -

[0020] The top wall 102 may be provided with a plurality of engageable protrusions 106 protruding from the inner surface of the top wall 102. The protrusions 106 may be arranged in a spoke-like formation, and may be designed to facilitate rotation of the closure 10 in a mold during manufacture, as described further below. Although FIG. 3 shows eight protrusions 106 arranged evenly in a spoke-like formation, it should be understood that other numbers and/or arrangements of protrusions 106 may be suitable.

[0021] The top wall 102 may include a first continuous annular ridge 110, also referred to as a first bead, in the vicinity of and offset from the periphery 103 of the top wall 102. The first annular ridge 110 may protrude inwardly from the top wall 102 and be designed to fit with the opening of the bottle, when the cap portion 100 is closed over the opening, to help inhibit leakage of liquid from the bottle. The top wall 102 may have a stopper 112 extending inwardly therefrom. The stopper 112 may be designed to fit snugly within the opening of the bottle, when the cap portion 100 is closed over the opening, to help inhibit leakage of liquid from the bottle. The stopper 112 may be substantially tubular in shape (e.g., where the opening in the bottle is circular in shape), and may flare out and/or thicken as it extends from the top wall 102, in order to more snugly fit within the opening of the bottle and to help provide a liquid-tight seal against the bottle.

[0022] The side wall 104 may be provided with a second continuous annular ridge 108, also referred to as a second bead, protruding inwardly from the side wall 104. The second annular ridge 108 may be designed to fit with the outside surface of the neck of the bottle, to help inhibit leakage of liquid from the bottle.

[0023] The presence of the first and/or second continuous annular ridge 110, 108, together with the stopper 112, may help to ensure a liquid-tight seal between the cap portion 100 and the bottle opening, while accommodating acceptable or expected dimensional tolerances. This arrangement may help to ensure a liquid-tight seal in a snap-on closure, without requiring the use of threads (as in a screw-

- 6 -

on closure). By providing the closure 10 as a snap-on closure, rather than a screw-on closure, the closure 10 may be used to close openings in bottles, such as milk bottles, which conventionally do not have threads. Although the drawings show an example closure 10 having both first and second annular ridges 110, 108, in some
5 example there may be only one annular ridge 110, 108, while still providing a suitable seal.

[0024] A cap tab 114 may be provided on the outside surface of the cap portion 100, for example on the outside surface of the side wall 104. The cap tab 114 may facilitate manual removal of the cap portion 100 from the opening of the
10 bottle.

[0025] The latch ring portion 200 may include a plurality of resiliently deformable teeth 202 extending from the inner surface of the latch ring portion 200. The teeth 202 may extend inwardly and towards the cap portion 100. The teeth 202 may be connected to the latch ring portion 200 at a proximal end 204
15 and may be reinforced (e.g., thicker and/or having an inwardly-extending ridge) at the distal end 206. The teeth 202 may be designed to engage the latch ring portion 200 onto the neck of the bottle, when the closure 10 is fitted onto the opening of the bottle. The reinforcement of the teeth 202 at the distal end 206 may help the
20 teeth 202 to more effectively engage with the neck of the bottle, and prevent removal of the latch ring portion 200 from the bottle by brute force (i.e., without using rupturing the frangible connector 300). The teeth 202 may extend from the inner surface of the latch ring portion 200 in a non-perpendicular angle that facilitates fitting the latch ring portion 200 down over the neck of the bottle but that resists removal of the latch ring portion 200, once it has been fitted over the bottle.
25 The resiliency of the teeth 202 may be such that they can be bent back against the inner surface of the latch ring portion 200 to enable the closure 10 to be fitted over the neck of the bottle, and they can resiliently return to the unbent position to prevent removal of the closure 10 from the bottle unless the latch ring portion 200 is removed, as described below.

- 7 -

[0026] In the example shown, there are five teeth 202 extending from the latch ring portion 200, however there may be more or less teeth 202, as suitable. The dimensions of the teeth 202 may be adjusted to ensure that the teeth 202 sufficiently engage with the neck of the bottle, to prevent removal of the closure 10 from the bottle by brute force. For example, where there are fewer teeth 202, the width of each tooth 202 may be wider, so that each tooth 202 extends along a greater portion of the latch ring portion 200. In another example, where there are more teeth 202, the width of each tooth 202 may be narrower, so that each tooth 202 extends along a lesser portion of the latch ring portion 200.

10 **[0027]** The latch ring portion 200 may include a latch tab 208 projecting from the outer surface of the latch ring portion 200. The latch tab 208 may facilitate application of a manual force to rupture the frangible connector 300 and disconnect the cap portion 100 from the latch ring portion 200. For example, the latch tab 208 may be bent back by a manual force and gripped to rip open the frangible
15 connector 300.

[0028] The latch ring portion 200 may not be a continuous ring, but instead may include a gap 210 at or near the location of the latch tab 208. This gap may be bridged by a thin, frangible bar 212. The presence of the gap 210 may facilitate rupture of the frangible connector 300 by allowing the latch tab 208 to be more
20 easily bent back. The frangible bar 212 may help keep the latch tab 208 from being unintentionally bent back, and the frangible bar 212 may be broken when manual force is applied to the latch tab 208.

[0029] When the closure 10 is fitted over the neck of the bottle and prior to rupture of the frangible connector 300, the presence of the teeth 202 and the
25 connection of the cap portion 100 to the latch ring portion 200 (via the frangible connector 300) may prevent the cap portion 100 from being removed from the bottle opening. When force is applied to the latch tab 208, the frangible connector 300 may be ruptured and the latch ring portion 200 may be removed (e.g., torn off

- 8 -

laterally) from the cap portion 100. Disconnection of the cap portion 100 from the latch ring portion 200 may allow the cap portion 100 to be removed from the opening of the bottle. In some examples, the latch ring portion 200 may not be fully disconnected from the cap portion 100, but may be only partially disconnected from the cap portion 100, sufficient to disengage the teeth 202 from the neck of the bottle and permit removal of the cap portion 100 from the opening. Regardless, rupture of the frangible connector 300 may provide visible evidence that the bottle has been opened or tampered with. As explained above, the teeth 202 may be sufficiently robust to prevent removal of the closure 10 from the bottle unless the frangible connector 300 is ruptured. After the cap portion 100 is removed from the opening of the bottle, the cap portion 100 may be fitted back (e.g., snapped on) over the opening, to reclose the opening with a liquid-tight seal. The now disconnected latch ring portion 200 may be discarded.

[0030] The closure 10 may be manufactured in a one-piece molding process, using a single mold. All the components of the closure 10 may be molded integrally. This one-step process may help to simplify manufacturing and/or reduce manufacturing costs. This one-piece molding process may also be useful to control the dimensions of the closure 10 to within a relatively tight dimensional tolerance (e.g., within $\pm 0.005''$), to help ensure that the cap portion 100 forms a liquid-tight seal when fitted on the opening. The closure 10 may be molded using any suitable polymer, for example any suitable food-grade plastic when used as a closure for a food container (e.g., used as a cap on a milk bottle). Suitable polymers may include polypropylene, for example. In some examples, a combination of two or more polymers may be used. Additives such as colorants and/or UV inhibitors, for example, may be added.

[0031] FIG. 7 is a flowchart illustrating an example method 400 for manufacturing a tamper evident closure, such as the closure 10 described above.

- 9 -

[0032] At 402, a suitable polymer is injected into a mold, and the closure 10 is formed in the mold using suitable one-piece molding techniques. Conventionally, release of the molded closure 10 from the mold may involve simply pushing the molded closure 10 out of the mold. However, because the teeth 202 protrude inwardly at an angle, they may be caught in the corresponding mold cavities that were used to mold the teeth 202. Conventionally, the teeth 202 may thus need to be bent back in order to be released from the mold. This may require that the teeth 202 be relatively bendable (e.g., formed to be relatively thin) and/or may damage the integrity of the teeth 202. The result is that the robustness of the teeth 202 may be compromised, decreasing the ability of the teeth 202 to resist removal of the latch ring portion 200 by brute force (i.e., without rupturing the frangible connector 300).

[0033] In the present disclosure, the presence of engageable protrusions 106 allow the molded closure 10 to be engaged, at 404, by a release apparatus (e.g., an apparatus having protrusions or depressions complementary to the protrusions 106 on the closure 10) and rotated, at 406, to a release position. When the closure 10 is rotated to the release position, the closure 10 may be still within the mold but be rotated such that the teeth 202 are freed from their corresponding mold cavities, without having to sacrifice the robustness of the teeth 202.

[0034] At 408, the molded closure 10 may be released from the mold. Since the teeth 202 have been rotated out from their corresponding mold cavities, the release of the molded closure 10 may be accomplished without having to bend back or risk damage to the teeth 202.

[0035] Because the teeth 202 are freed from the mold cavities by this rotating operation and do not need to be bent back against the mold to be released, the teeth 202 may be designed to be thicker, more robust and may include a reinforced section at the distal end 206. The reinforced section at the distal end 206 can be made perpendicular to the sidewall, for more robust gripping of the neck of the

- 10 -

bottle, enhancing the tamper-evident qualities of the closure. Thus, the method 400 may facilitate manufacture of a closure 10 that is more resistant to brute force removal from the bottle.

[0036] Once the closure 10 has been molded, it may be cleaned, labeled and
5 fitted over the opening of the bottle using suitable techniques.

[0037] The embodiments of the present disclosure described above are intended to be examples only. The present disclosure may be embodied in other specific forms. Alterations, modifications and variations to the disclosure may be made without departing from the intended scope of the present disclosure. While
10 the systems, devices and processes disclosed and shown herein may comprise a specific number of elements/components, the systems, devices and assemblies could be modified to include additional or fewer of such elements/components. For example, while any of the elements/components disclosed may be referenced as being singular, the embodiments disclosed herein could be modified to include a
15 plurality of such elements/components.

All values and sub-ranges within disclosed ranges are also disclosed. The subject matter described herein intends to cover and embrace all suitable changes in technology.

20

WE CLAIM:

1. A one piece molded tamper evident push-on closure suitable for closing an opening of a bottle, comprising:

a cap portion comprising a sidewall and a top wall;

a plurality of engageable protrusions on an inner surface of the top wall of the cap portion for engaging with a rotator means for rotation of the closure to a release position for removal from a mold;

a latch ring portion;

a plurality of resiliently deformable teeth extending inwardly from the latch ring portion and towards the cap portion for engaging the latch ring portion onto a neck of the bottle, each of said teeth being connected to the latch ring portion at a proximal end and having a distal end; and

a frangible connector connecting the cap portion and the latch ring portion.

2. The closure of claim 1, further comprising a manually engageable tab projecting from the latch ring portion to permit application of a manual force to rupture the frangible connector and permit the cap portion to be at least partially disconnected from the latch ring portion.

3. The closure of claim 1 or 2, further comprising a first continuous annular ridge protruding inwardly from the top wall of the cap portion for engaging an outer edge of a lip around the opening of the bottle.

4. The closure of any one of claims 1 to 3, further comprising a second continuous ridge protruding inwardly from the sidewall of the cap portion for engaging the neck of the bottle.

5. The closure of any one of claims 1 to 4, further comprising a stopper extending from the inner surface of the top wall of the cap portion for fitting inside the opening of the bottle to provide a liquid-tight seal against an inner edge of the lip around the opening.

6. The closure of claim 5, wherein the stopper has a substantially tubular cross-section that flares outwardly as it extends from the inner surface of the top wall.
7. The closure of any one of claims 1 to 6, wherein the frangible connector comprises a section of material that has a thickness less than a thickness of the latch ring portion.
8. The closure of any one of claims 1 to 7, wherein the distal end of each of said teeth comprises a reinforced inwardly extending ridge.
9. The closure of any one of claims 1 to 7, wherein the engageable protrusions are arranged in a radial spoke-like formation on the inner surface of the top wall.
10. A method for manufacturing a one piece molded tamper evident push-on closure, the method comprising:
 - injecting a polymer into a mold to mold the closure, the mold including mold cavities to mold protruding teeth, said protruding teeth protruding from an inner side of a side wall of the closure, to form a molded closure;
 - engaging protrusions on a top wall of the molded closure and rotating the molded closure within the mold, the closure being rotated on one plane to a release position in which the protruding teeth of the closure are free from the corresponding mold cavities; and
 - releasing the molded closure from the mold.
11. The method of claim 10 wherein engaging the protrusions comprises engaging the protrusions on an inner surface of the top wall of the molded closure.
12. The method of claim 10 or 11 wherein the protrusions are arranged in a radial spoke-like formation.
13. The method of any one of claims 10 to 12 for manufacturing the closure of claim 1.

14. A one piece molded push-on closure suitable for closing an opening of a bottle, comprising:

a cap portion comprising a sidewall and a top wall;

a stopper extending from an inner surface of the top wall of the cap portion for fitting inside the opening of the bottle to provide a liquid-tight seal against an inner edge of a lip around the opening;

a first continuous annular ridge protruding inwardly from the top wall of the cap portion for engaging an outer edge of the lip around the opening of the bottle to provide a further liquid-tight seal against the outer edge of the lip around the opening; and

a second continuous ridge protruding inwardly from the sidewall of the cap portion for engaging a neck of the bottle.

15. The closure of claim 14, further comprising

a latch ring portion;

a plurality of resiliently deformable teeth extending inwardly from the latch ring portion and towards the cap portion for engaging the latch ring portion onto the neck of the bottle; and

a frangible connector connecting the cap portion and the latch ring portion.

16. The closure of claim 15, further comprising a manually engageable tab projecting from the latch ring portion to permit application of a manual force to rupture the frangible connector and permit the cap portion to be at least partially disconnected from the latch ring portion.

17. The closure of any one of claims 14 to 16, wherein the stopper has a substantially tubular cross-section that flares outwardly as it extends from the inner surface of the top wall.

18. The closure of any one of claims 15 to 17, wherein the frangible connector comprises a section of material that has a thickness less than a thickness of the latch ring portion.

19. The closure of any one of claims 15 to 18, wherein a reinforced distal end of each of said teeth comprises an inwardly extending ridge.

20. A molded tamper evident push-on closure suitable for closing an opening of a bottle, comprising:

a cap portion comprising a sidewall and a top wall;

a latch ring portion;

a plurality of resiliently deformable teeth extending at an angle inwardly from the latch ring portion and upwardly towards the cap portion to an apex, for engaging the latch ring portion onto a neck of the bottle, each of said teeth being connected to the latch ring portion at a proximal end and having a distal end; and

a frangible connector connecting the cap portion and the latch ring portion;

wherein each of said teeth has a ridge extending inwardly from said apex, perpendicular to said sidewall.

21. The closure of claim 20, further comprising a manually engageable tab projecting from the latch ring portion to permit application of a manual force to rupture the frangible connector and permit the cap portion to be at least partially disconnected from the latch ring portion.

22. The closure of claim 20 or 21, further comprising a first continuous annular ridge protruding inwardly from the top wall of the cap portion for engaging an outer edge of a lip around the opening of the bottle.

23. The closure of any one of claims 20 to 22, further comprising a second continuous ridge protruding inwardly from the sidewall of the cap portion for engaging the neck of the bottle.

24. The closure of any one of claims 20 to 23, further comprising a stopper extending from an inner surface of the top wall of the cap portion for fitting inside the opening of the bottle to provide a liquid-tight seal against an inner edge of a lip around the opening.

25. The closure of claim 24, wherein the stopper has a substantially tubular cross-section that flares outwardly as it extends from the inner surface of the top wall.

26. The closure of any one of claims 20 to 25, wherein the frangible connector comprises a section of material that has a thickness less than a thickness of the latch ring portion.

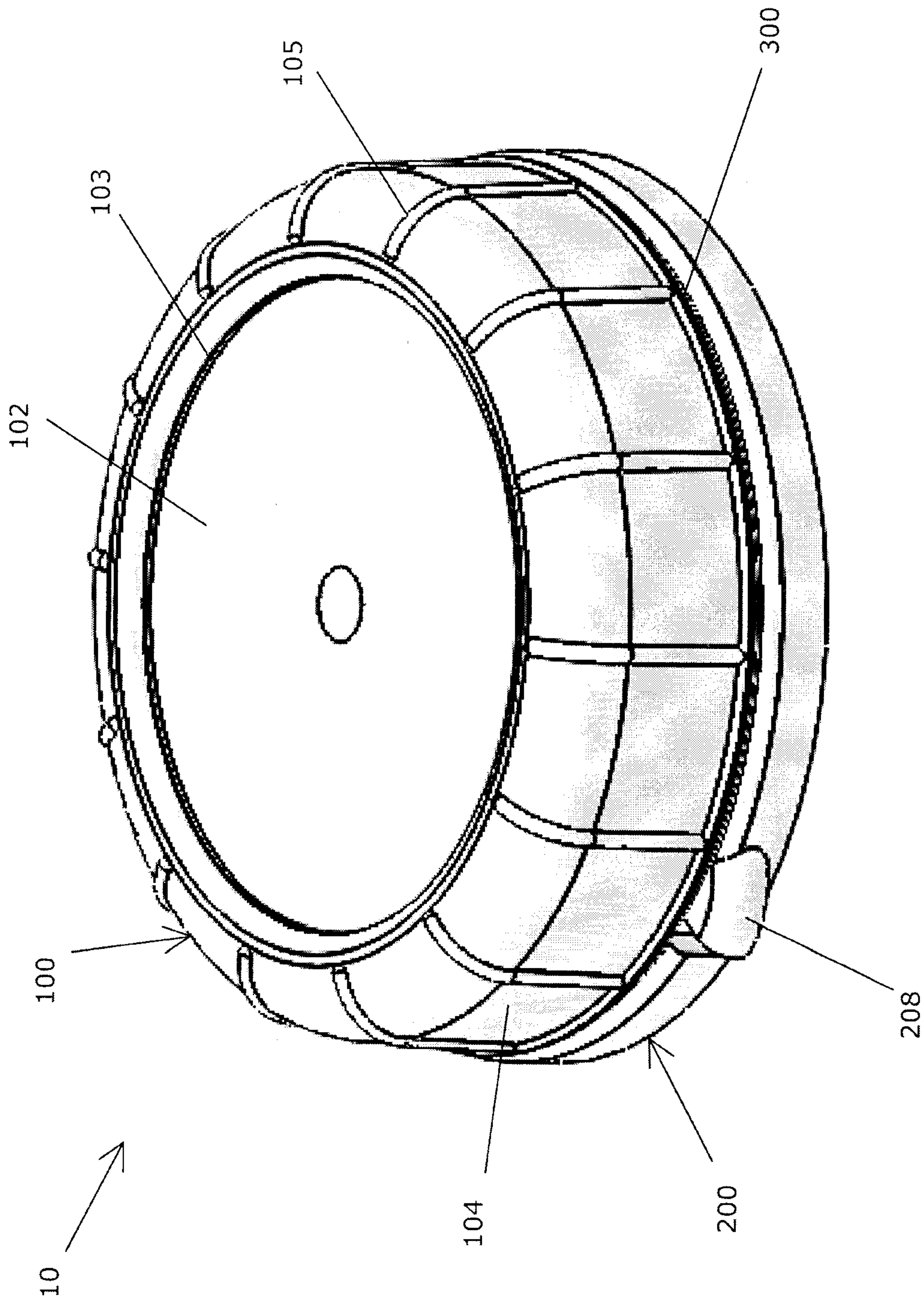

FIG.1

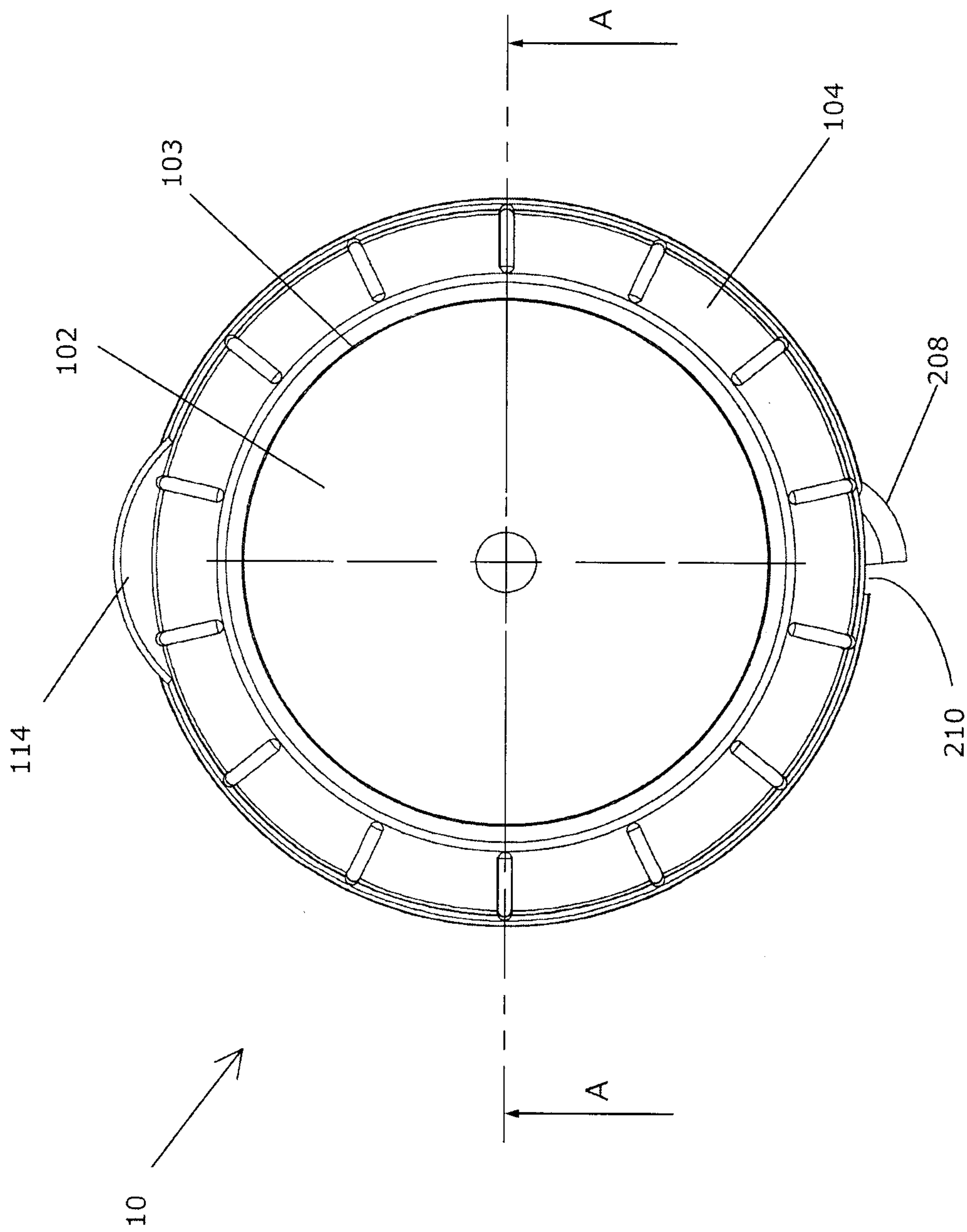

FIG.2

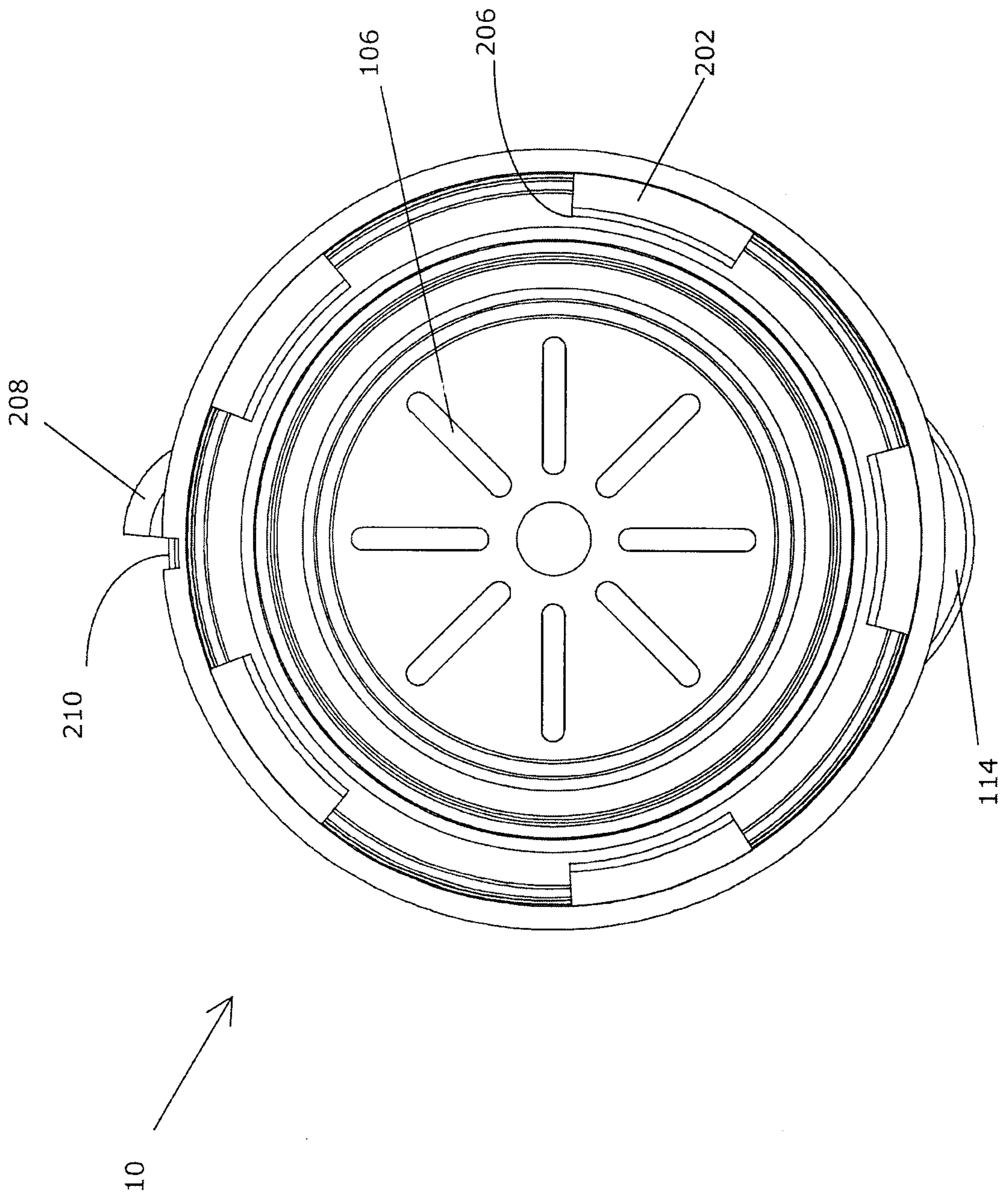

FIG.3

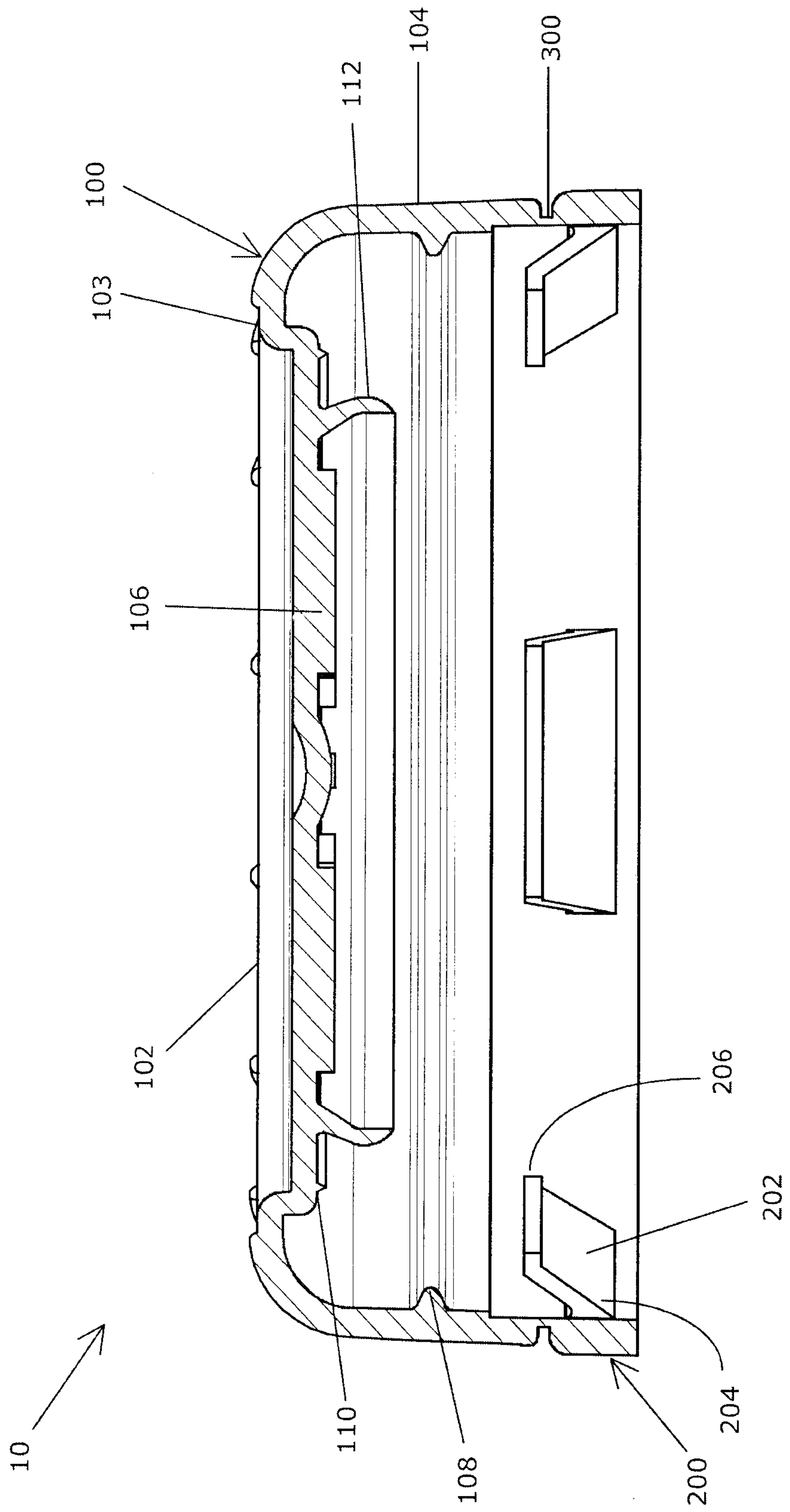

FIG. 4

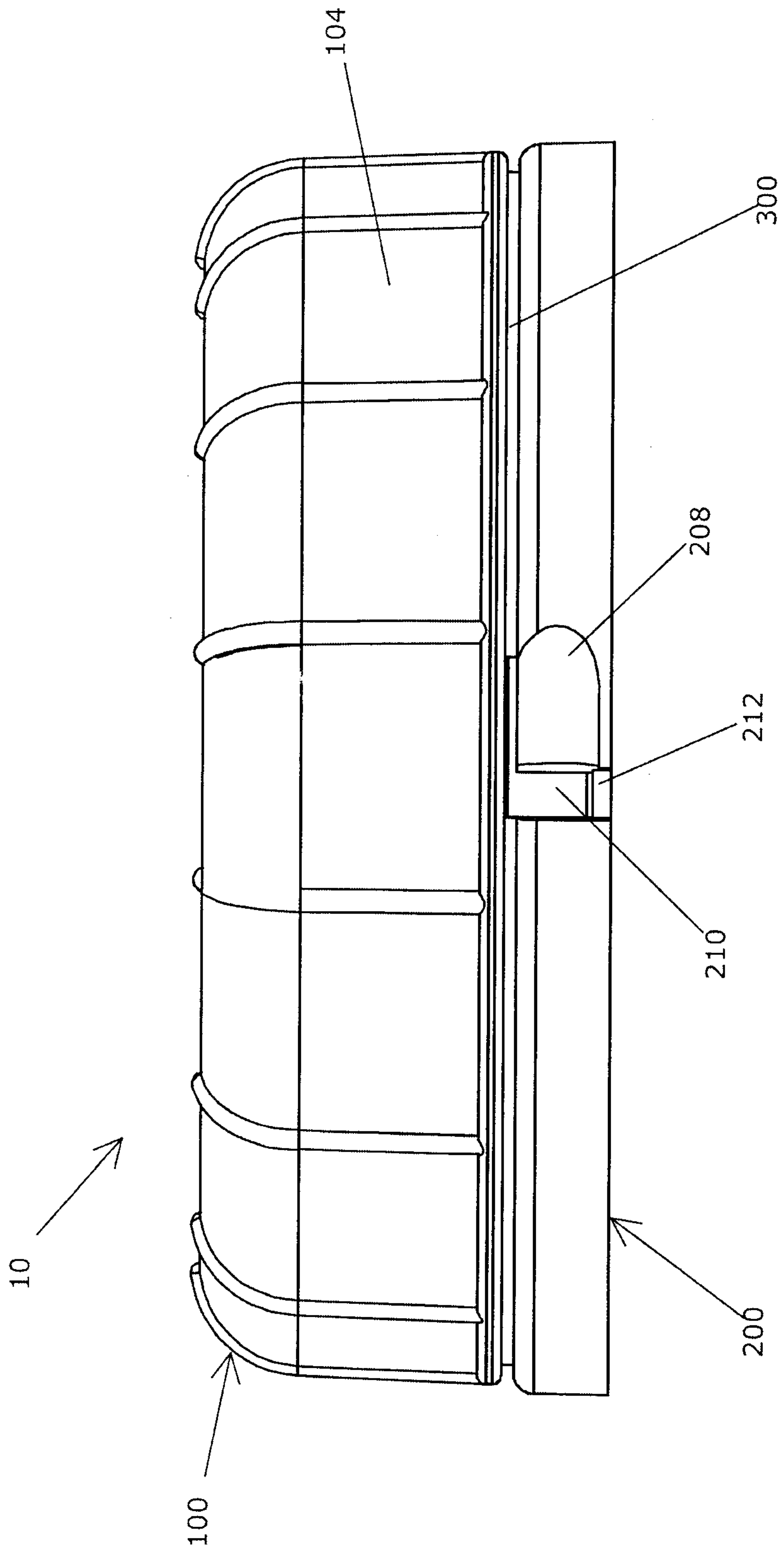

FIG.5

6/7

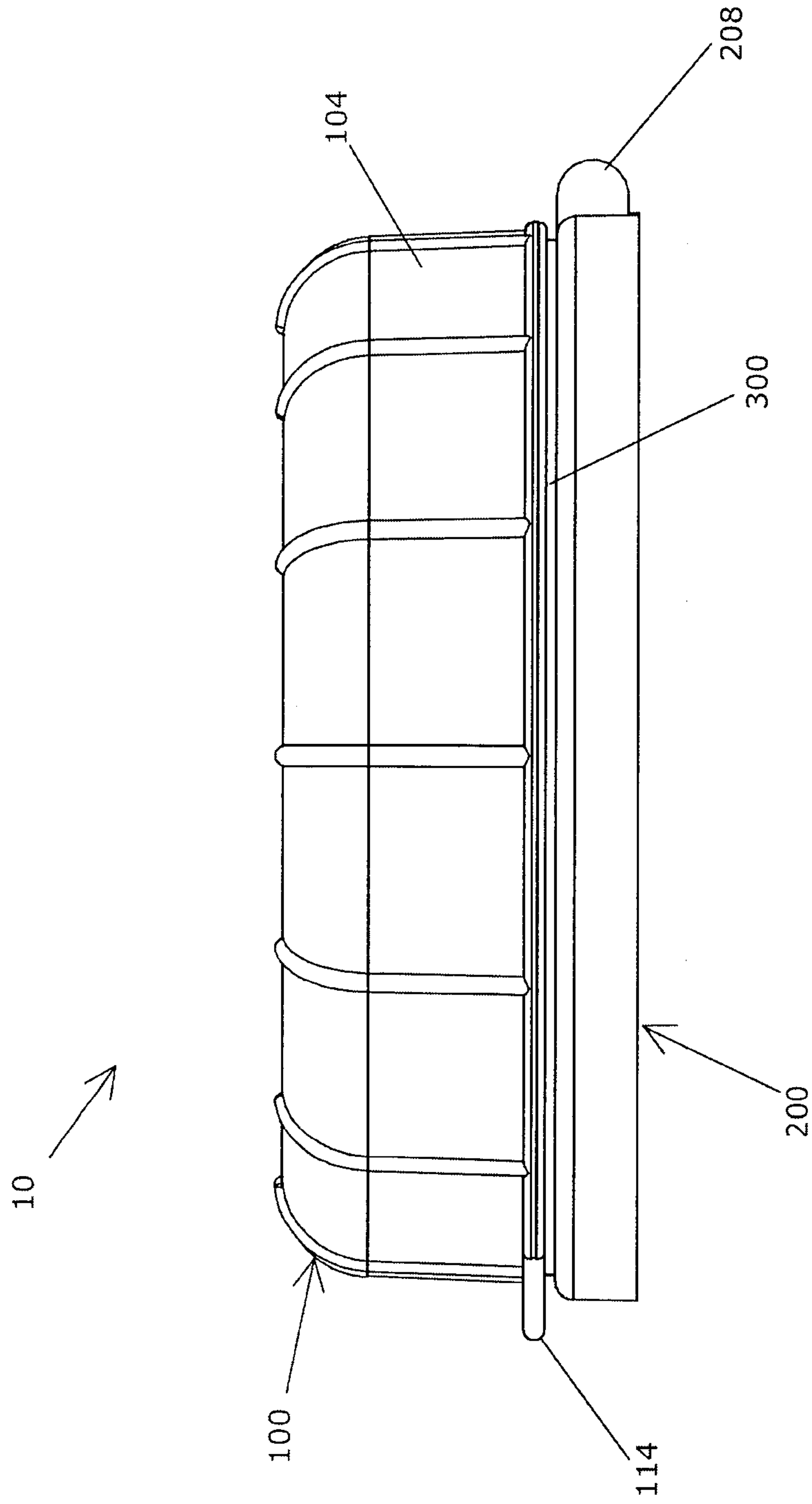

FIG.6

7/7

400

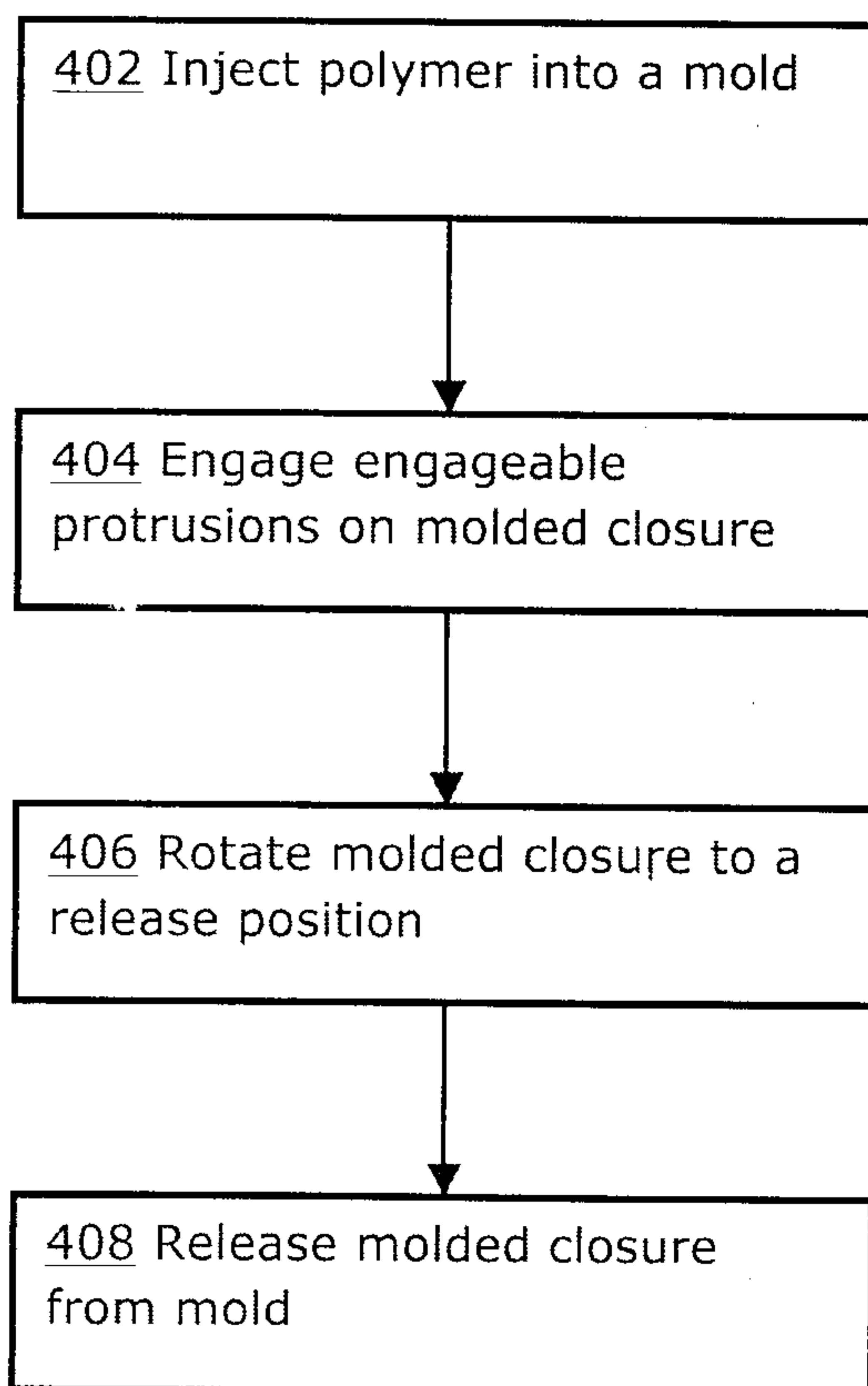



FIG.7

