

(19) World Intellectual Property Organization  
International Bureau



(43) International Publication Date  
16 April 2009 (16.04.2009)

PCT

(10) International Publication Number  
WO 2009/048375 A1

- (51) International Patent Classification:  
A61F 2/04 (2006.01) A61N 1/36 (2006.01)  
A61B 17/12 (2006.01)
- (21) International Application Number:  
PCT/SE2008/000564
- (22) International Filing Date: 10 October 2008 (10.10.2008)
- (25) Filing Language: English
- (26) Publication Language: English
- (30) Priority Data:  
60/960,715 11 October 2007 (11.10.2007) US
- (71) Applicant (for all designated States except US): MILUX HOLDING SA [LU/LU]; 6 rue Guillaume Schneider, L-2522 Luxembourg (LU).
- (72) Inventor; and
- (75) Inventor/Applicant (for US only): FORSELL, Peter [SE/CH]; Aegeristrasse 66, CH-6300 Zug (CH).
- (74) Agent: BERGENSTRÅHLE & LINDVALL AB; Box 17704, S-118 93 Stockholm (SE).
- (81) Designated States (unless otherwise indicated, for every kind of national protection available): AE, AG, AL, AM, AO, AT, AU, AZ, BA, BB, BG, BH, BR, BW, BY, BZ, CA, CH, CN, CO, CR, CU, CZ, DE, DK, DM, DO, DZ, EC, EE, EG, ES, FI, GB, GD, GE, GH, GM, GT, HN, HR, HU, ID, IL, IN, IS, JP, KE, KG, KM, KN, KP, KR, KZ, LA, LC, LK, LR, LS, LT, LU, LY, MA, MD, ME, MG, MK, MN, MW, MX, MY, MZ, NA, NG, NI, NO, NZ, OM, PG, PH, PL, PT, RO, RS, RU, SC, SD, SE, SG, SK, SL, SM, ST, SV, SY, TJ, TM, TN, TR, TT, TZ, UA, UG, US, UZ, VC, VN, ZA, ZM, ZW.
- (84) Designated States (unless otherwise indicated, for every kind of regional protection available): ARIPO (BW, GH, GM, KE, LS, MW, MZ, NA, SD, SL, SZ, TZ, UG, ZM, ZW), Eurasian (AM, AZ, BY, KG, KZ, MD, RU, TJ, TM), European (AT, BE, BG, CH, CY, CZ, DE, DK, EE, ES, FI, FR, GB, GR, HR, HU, IE, IS, IT, LT, LU, LV, MC, MT, NL,

[Continued on next page]

(54) Title: APPARATUS FOR CONTROLLING FLOW OF URINE IN BLADDER OR URETHRA

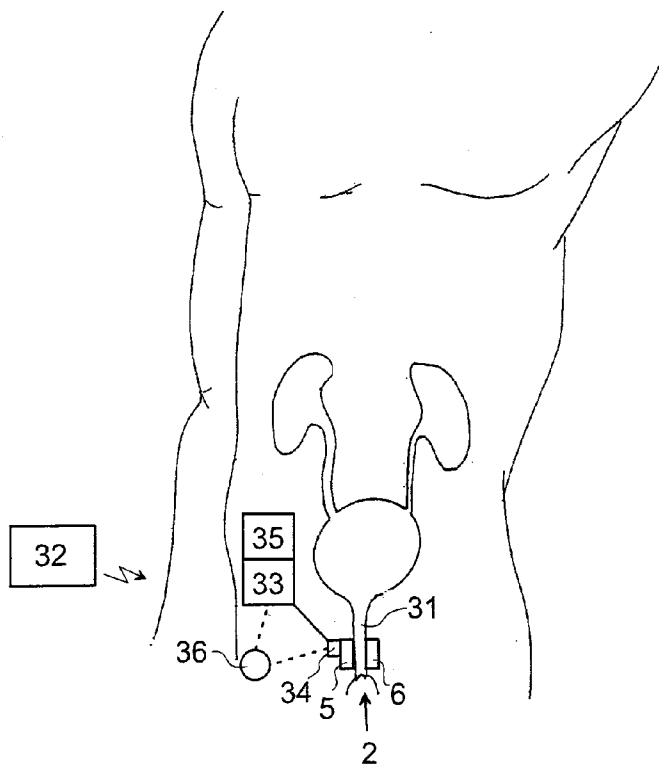

Fig. 14A

(57) Abstract: An apparatus for controlling flow of urine in a patient suffering from urinary incontinence comprises an implantable constriction device for gently constricting (i.e. without substantially hampering the blood circulation in the tissue wall of the urethra, ureter, renal pelvis or bladder) at least one portion of the tissue wall of the urethra, ureter, renal pelvis or bladder to influence the flow of urine, and a stimulation device for stimulating the wall portion of the tissue wall. A control device controls the stimulation device to stimulate the wall portion, as the constriction device constricts the wall portion, to cause contraction of the wall portion constricted by the constriction device to further influence the flow of urine. The apparatus can be used for restricting or stopping the flow of urine, or for actively moving the urine in the urinary passageway, with a low risk of injuring the urethra, ureter, renal pelvis or bladder.

WO 2009/048375 A1



NO, PL, PT, RO, SE, SI, SK, TR), OAPI (BF, BJ, CF, CG,  
CI, CM, GA, GN, GQ, GW, ML, MR, NE, SN, TD, TG).

— *before the expiration of the time limit for amending the  
claims and to be republished in the event of receipt of  
amendments*

**Published:**

— *with international search report*

## TITLE OF THE INVENTION

APPARATUS FOR CONTROLLING FLOW OF URINE IN BLADDER OR URETHRA

## FIELD OF THE INVENTION

**[0001]** The present invention relates to controlling the flow of urine in the urethra, ureter, renal pelvis or urine bladder, and in particular, to an apparatus for controlling the flow of flow urine of a patient suffering from urinary dysfunction.

## BACKGROUND OF THE INVENTION

There are different kinds of urinary dysfunction that prevent a patient from maintaining normal control of the flow of urine in the patient's urethra, ureter, renal pelvis or bladder. For example, overflow incontinence, stress incontinence and urge incontinence. (The term "patient" generally includes human beings, but may also include animals.)

Overflow incontinence involves disability of controlling the muscle that contracts the urine bladder. In particular partially paralysed patients may suffer from this condition. Stress incontinence involves disability to keep the urethral sphincter completely closed. In a urinary stress incontinent patient the urethral sphincter is unable to prevent urine from being expelled from the bladder during transient increase in intra-abdominal pressure, which can be caused by sneezing, coughing or laughing, or by lifting heavy goods. Urge incontinence involves spontaneous activity of the bladder causing a compelling feeling of the patient that the bladder needs to be emptied, although the bladder maybe contains little urine.

Urinary stress and urge incontinences are widespread diseases. Although some people suffering from these diseases are helped through training of the muscles in the pelvic floor, too many have severe problems with urine leakage. Many different implant devices have been tried to remedy this kind of urinary incontinence. For example, there is a prior manually operated urinary incontinence treatment apparatus having an artificial hydraulic sphincter device engaging the urethra and

connected to an elastic reservoir implanted in the scrotum or in the region of the labia majora. A disadvantage of this prior apparatus is that over time hard fibrosis is developed around the reservoir, which may cause malfunction of pumping components. Furthermore, it is a rather complicated task to manually squeeze the elastic implanted reservoir to pump hydraulic fluid to open the sphincter device when the patient needs to urinate. In particular women can get their fingers wet. The created fibrosis will sooner or later become a hard fibrotic layer, which may make it even more difficult to pump the reservoir. Yet a further disadvantage is that the use of hydraulic fluid always entails a risk of fluid leaking from implanted hydraulic components.

A prior hydraulic apparatus designed to compress the urethra is disclosed in U.S. Pat. No. 5520606. A prosthetic sphincter with an inflatable cuff, which surrounds the urethra or encloses it on two sides, is disclosed in for example U.S. Pat. Nos. 4,571,749 and 4,222,377. U.S. Pat. No. 4969474 discloses a hydraulic method for treating both men and women having urinary stress incontinence in the same way. The apparatus of U.S. Pat. No. 4,969,474 includes a reservoir containing fluid and an inflatable compression means designed to compress the urethra without risking tissue loss or necrosis to occur. An artificial hydraulically operated urethral sphincter employing an external magnet to achieve closure of the urethral cuff is disclosed in U.S. Pat. No. 5,562,598.

A prior mechanical prosthetic sphincter disclosed in U.S. Pat. No. 4,619,245 comprises a manually controllable actuating component for implanting at a convenient location in the patient's body.

U.S. Pat. No. 4,739,764 discloses a method for treating urinary stress incontinence by electric stimulation of an inferior somatic nerve connected to the urethral sphincter. The function of the urethral sphincter is affected by applying electric pulse trains on the somatic nerve.

U.S. Pat. No. 6,061,596 discloses a system for regularly conditioning and training the pelvic muscles of a urinary stress or urge incontinent patient with electric stimulation so as to restore voluntary control to the patient. The pelvic muscles are stimulated, i.e. conditioned, for 15-60 minutes each day using intermittent trains of electrical pulses. Accordingly, during the rest of each day, i.e. at least 23 hours, the pelvic muscles are not stimulated.

**[0002]** U.S. Pat. Appl. Publication No. 2002/0062060 A1 discloses a urinary stress or urge incontinence treatment device, which is sensor controlled and is normally not in operation unless signals from the sensors indicate a condition that is likely to cause involuntary urine flow. The sensors generate signals responsive to motion or to intravesical or abdominal pressure, or to urine volume in the bladder. The signals from the sensors are indicative of possible incontinence that may occur due to coughing, laughing, or other strain or motion of abdominal muscles.

**[0003]** One general prior solution to the problem of malfunctioning sphincters of a human body has been to implant an artificial sphincter that replaces a malfunctioning sphincter. A variety of artificial sphincters have been used in the past. These artificial sphincters have included cuffs, clamping elements or inflatable bands that are applied externally around the bodily organ that is connected to the malfunctioning sphincter.

**[0004]** For example, U.S. Patent No. 3,750,194 discloses a hydraulic cuff applied around the urethra of a patient suffering from urinary incontinence. Hydraulic fluid flowing to the hydraulic cuff causes the cuff to squeeze the urethra and restrict fluid flow through it.

**[0005]** U.S. Patent No. 6,074,341 discloses a mechanical device in the form of a loop member that is applied around a bodily organ to replace the organ's missing or damaged sphincter. The loop member includes a wire which is used to constrict the organ in question to close the lumen therein.

**[0006]** A disadvantage common to all prior artificial sphincters is that hard fibrosis may form around the artificial sphincter over time and may cause malfunction of the artificial sphincter. Thus, the formed fibrosis may sooner or later become a hard fibrotic layer which may make it difficult for the artificial sphincter to work.

**[0007]** Another more serious disadvantage of the prior artificial sphincters if used for replacing malfunctioning urethral sphincters is that the element that constricts, clamps or restricts the urethra may injure the tissue wall of the urethra. Thus, a consequence of the element's constricting action on the urethra is that the element might erode into the urethra over time, and in a worst case, penetrate the constricted wall portion of the urethra. In addition, blood circulation in the constricted tissue wall portion of the urethra is eventually hampered by the pressure exerted by the element, so that poor blood circulation, or worse, no blood circulation results in deterioration of the constricted tissue.

**[0008]** One solution to prevent tissue deterioration due to poor blood circulation could be to apply two or more separately operating constricting elements along respective tissue wall portions of the urethra and operate the elements sequentially, whereby each tissue wall portion would have time to recover, *i.e.*, restore normal blood circulation while one of the other tissue wall portions is constricted. However, an apparatus devised in accordance with this solution would have several disadvantages. First, the apparatus would require a large amount of space, making it impractical to implant. Second, the operation of the apparatus in moving the constricting elements between constricting and non-constricting positions day and night would require a large power supply. Such a large power supply would necessitate the implantation of a very large, high capacity battery and/or a sophisticated system for continuous wireless transmission of energy from outside the patient's body for frequent charging of an implanted rechargeable battery. Thus, because of its large size and high power consumption, the apparatus would be impractical or even unrealistic. Third, a sophisticated control system would be necessary to control the moving elements. Finally, such a complicated apparatus of the type described above would significantly add to the costs of treating a malfunctioning sphincter.

**[0009]** Another solution to the problem of malfunctioning sphincters that has been previously used has been the electric stimulation of the sphincter, to restore its normal function, *i.e.*, the contraction and closing of its associated lumen. This solution would work where the normal sphincteric function is somewhat reduced and has not completely ceased. European patent application 1004330 A1 discloses an example of such a solution, in which electric pulses are delivered to the lower esophageal sphincter of a patient suffering from reflux disease to minimize reflux. However, the esophageal sphincter has to be continuously stimulated with electric pulses to keep it closed, except when the patient eats, which may result in a decreased stimulation effect over time. An even more serious drawback to this solution is that the continuous stimulation over time might cause tissue deterioration due to poor blood circulation.

**[0010]** The use of electric stimula to restore the sphincteric function of a malfunctioning urethral sphincter is only possible if the sphincter responds sufficiently to the stimula, *i.e.*, closes the urethra. In cases where the sphincteric

function of a urethral sphincter has completely ceased, or the urethral sphincter has been removed from the patient's body, electric stimulation cannot be employed.

**[0011]** Electric stimulation of urinary organs other than urethral sphincters can only insignificantly affect the flow of urine. For example, it is true that electric stimulation of the urethra affects flow of urine, but could not possibly fully close the relatively stiff urethra, at least not by employing the necessary low stimulation intensities that are harmless to the human body.

### BRIEF SUMMARY OF THE INVENTION

**[0012]** The object of the present invention is to provide an apparatus for controlling the flow of urine in urinary passageways formed by tissue walls of the urethra, ureter, renal pelvis or bladder, so as to at least substantially or even completely eliminate the injured tissue wall problems that have resulted from implanted prior art devices that constrict such bodily organs.

**[0013]** In accordance with this object of the present invention, there is provided an apparatus for controlling the flow of urine in a urinary passageway formed by the tissue wall of the urethra, ureter, renal pelvis or bladder, the apparatus comprising an implantable constriction device for gently constricting a portion of the tissue wall to influence the flow of urine, a stimulation device for stimulating the wall portion of the tissue wall, and a control device for controlling the stimulation device to stimulate the wall portion as the constriction device constricts the wall portion to cause contraction of the wall portion to further influence the flow of urine.

**[0014]** The present invention provides an advantageous combination of constriction and stimulation devices, which results in a two-stage influence on the flow of urine. Thus, the constriction device may gently constrict the tissue wall of the urethra, ureter, renal pelvis or bladder by applying a relatively weak force against the wall portion, and the stimulation device may stimulate the constricted wall portion to achieve the desired final influence on the flow of urine. The phrase "gently constricting a portion of the tissue wall" is to be understood as constricting the wall portion without substantially hampering the blood circulation in the tissue wall of the urethra, ureter, renal pelvis or bladder.

**[0015]** Preferably, the stimulation device is adapted to stimulate different areas of the wall portion as the constriction device constricts the wall portion, and the control

device controls the stimulation device to intermittently and individually stimulate the areas of the wall portion. This intermittent and individual stimulation of different areas of the wall portion of the urethra, ureter, renal pelvis or bladder allows tissue of the wall portion to maintain substantially normal blood circulation during the operation of the apparatus of the invention.

**[0016]** The combination of the constriction and stimulation devices enables application of the apparatus of the invention at any place on the urethra, ureter, renal pelvis or bladder, which is a significant advance in the art, as compared with prior stimulation devices that are confined to electric stimulation of malfunctioning urethral sphincters.

**[0017]** In most applications using the present invention, there will be daily adjustments of the implanted constriction device. Therefore, in a preferred embodiment of the invention, the constriction device is adjustable to enable adjustment of the constriction of the wall portion as desired, wherein the control device controls the constriction device to adjust the constriction of the wall portion. The control device may control the constriction and stimulation devices independently of each other, and simultaneously. Optionally, the control device may control the stimulation device to stimulate, or to not stimulate the wall portion while the control device controls the constriction device to change the constriction of the wall portion.

**[0018]** Initially, the constriction device may be calibrated by using the control device to control the stimulation device to stimulate the wall portion, while controlling the constriction device to adjust the constriction of the wall portion until the desired restriction of the flow of urine is obtained.

#### Flow restriction

**[0019]** The apparatus of the present invention is well suited for restricting the flow of urine in the urinary passageway. Thus, in a principal embodiment of the invention, the constriction device is adapted to constrict the wall portion to at least restrict the flow of urine, and the control device controls the stimulation device to cause contraction of the constricted wall portion, so that the flow of urine is at least further restricted. Specifically, the constriction device is adapted to constrict the wall portion to a constricted state in which the blood circulation in the constricted wall portion is



substantially unrestricted and the flow of urine is at least restricted, and the control device controls the stimulation device to cause contraction of the wall portion, so that the flow of urine is at least further restricted when the wall portion is kept by the constriction device in the constricted state.

**[0020]** The constriction and stimulation devices may be controlled to constrict and stimulate, respectively, to an extent that depends on the flow restriction that is desired to be achieved in a specific application of the apparatus of the invention. Thus, in accordance with a first flow restriction option, the control device controls the constriction device to constrict the wall portion, such that flow of urine is restricted but not stopped, and controls the stimulation device to stimulate the constricted wall portion to cause contraction thereof, such that flow of urine is further restricted but not stopped. More precisely, the control device may control the stimulation device in a first mode to stimulate the constricted wall portion to further restrict but not stop the flow of urine and to:

a) control the stimulation device in a second mode to cease the stimulation of the wall portion to increase the flow of urine; or

b) control the stimulation and constriction devices in the second mode to cease the stimulation of the wall portion and release the wall portion to restore the flow of urine.

**[0021]** In accordance with a second flow restriction option, the control device controls the constriction device to constrict the wall portion, such that flow of urine is restricted but not stopped, and controls the stimulation device to stimulate the constricted wall portion to cause contraction thereof, such that flow of urine is stopped. More precisely, the control device may control the stimulation device in a first mode to stimulate the constricted wall portion to further restrict but not stop the flow of urine and to:

a) control the stimulation device in a second mode to cease the stimulation of the wall portion to allow flow of urine; or

b) control the stimulation and constriction devices in the second mode to cease the stimulation of the wall portion and release the wall portion to restore the flow of urine.

**[0022]** In accordance with a third flow restriction option, the control device controls the constriction device to constrict the wall portion, such that the flow of urine is substantially stopped, and controls the stimulation device to stimulate the constricted

wall portion to cause contraction thereof, such that the flow of urine is completely stopped. More precisely, the control device may control the stimulation device in a first mode to stimulate the constricted wall portion to completely stop the flow of urine and to:

a) control the stimulation device in a second mode to cease the stimulation of the wall portion to allow flow of urine; or

b) control the stimulation and constriction devices in the second mode to cease the stimulation of the wall portion and release the wall portion to restore the flow of urine.

**[0023]** The third flow restriction option is well suited for treating a urinary stress incontinent patient. Thus, the restriction and stimulation devices may be implanted on the stress incontinent patient's urethra, ureter, renal pelvis or lower part of the bladder to serve as an artificial urethral sphincter. Between urinations, the control device controls the constriction device to gently flatten a portion of the urethra, ureter, renal pelvis or bladder to at least almost completely stop the flow of urine in the urethra, and controls the stimulation device to stimulate the flattened portion to insure that the flow of urine is completely stopped. Since the control device controls the stimulation device to intermittently and individually stimulate the areas of the wall portion, as stated above in paragraph **0015**, the risk of the implanted constriction device injuring the urethra, ureter, renal pelvis or bladder over time is significantly reduced or even eliminated, and it is insured that the effect of the stimulation is maintained over time. When the patient wants to urinate, the control device controls the constriction and stimulation devices to release the portion of the urethra, ureter, renal pelvis or bladder and cease the stimulation, whereby urine may pass through the urethra. However, it should be noted that in some cases it may suffice to just cease the stimulation to achieve flow of urine through the urethra.

**[0024]** Where the stimulation device stimulates the constricted wall portion to contract, such that the flow of urine is stopped, the control device suitably controls the stimulation device to simultaneously and cyclically stimulate a first length of the constricted wall portion and a second length of the constricted wall portion, which is located downstream of the first length, wherein the control device controls the stimulation device to progressively stimulate the first length in the upstream direction of the urinary passageway and to progressively stimulate the second length in the downstream direction of the urinary passageway.

**[0025]** The control device may control the stimulation device to change the stimulation of the wall portion in response to a sensed physical parameter of the patient or functional parameter of the apparatus. For example, the control device may control the stimulation device to increase the intensity of the stimulation of the wall portion in response to a sensed pressure increase in the urinary passageway, such that the flow of urine remains stopped. Any sensor for sensing a physical parameter of the patient, such as a pressure in the patient's body that relates to the pressure in the urinary passageway may be provided, wherein the control device controls the stimulation device in response to signals from the sensor. Such a sensor may for example sense the pressure in the patient's abdomen, the pressure against the implanted constriction device or the pressure on the tissue wall of the urethra, ureter, renal pelvis or bladder.

**[0026]** Where a pressure sensor is provided, the constriction device constricts the urethra, ureter, renal pelvis or urine bladder, such that the urine flow is substantially stopped, and the stimulation device stimulates the constricted urethra, ureter, renal pelvis or urine bladder to cause contraction thereof to completely stop the urine flow. The control device controls the stimulation device to increase the stimulation intensity in response to signals from the pressure sensor sensing a sudden increase in the pressure in the patient's bladder or abdominal cavity, whereby the urine flow remains stopped and the patient maintains continence. In this manner, the present invention insures that the patient even is continent when he or she sneezes or coughs, or performs other physical activity that causes a sudden pressure increase in the patient's bladder/urinary tract.

**[0027]** In accordance with a fourth flow restriction option, the control device controls the constriction device to constrict the wall portion, such that the flow of urine is stopped. More precisely, the control device may control the constriction device in a first mode to constrict the constricted wall portion to stop the flow of urine and in a second mode to cease the constriction of the wall portion to restore flow of urine. In this case, the control device only controls the stimulation device to stimulate the wall portion when needed. A sensor for sensing a physical parameter of the patient's body that relates to the pressure in the urinary passageway may be provided, wherein the control device controls the stimulation device in response to signals from the sensor. Such a physical parameter may be a pressure in the patient's abdomen and the sensor may be a pressure sensor.

**[0028]** For example, the fourth flow restriction option may be applied where the present invention is used for controlling urine flow of a urinary stress or urge incontinent patient in a manner similar to the situation described in the foregoing paragraph **0026**. However, in this example stimulation is only applied when necessary to maintain continence. Thus, the control device controls the stimulation device to stimulate the urethra, ureter, renal pelvis or urine bladder to cause contraction thereof in response to signals from the pressure sensor sensing a sudden increase in the pressure in the patient's bladder or abdominal cavity, when the patient sneezes or coughs, or performs other physical activity. As a result, the urine flow remains stopped and the patient maintains continence.

**[0029]** In some applications of the invention, the implanted constriction device may be designed to normally keep the patient's wall portion of the urethra, ureter, renal pelvis or bladder in the constricted state. In this case, the control device may be used when needed, conveniently by the patient, to control the stimulation device to stimulate the constricted tissue wall portion, preferably while adjusting the stimulation intensity, to cause contraction of the wall portion, such that the flow of urine is at least further restricted or stopped, and to control the stimulation device to cease the stimulation. More precisely, the control device may:

a) control the stimulation device in a first mode to stimulate the constricted wall portion to further restrict the flow of urine, and control the stimulation device in a second mode to cease the stimulation of the wall portion to increase the flow of urine; or

b) control the stimulation device in a first mode to stimulate the constricted wall portion to stop the flow of urine, and control the stimulation device in a second mode to cease the stimulation of the wall portion to allow flow of urine.

**[0030]** Either the first mode or the second mode may be temporary.

**[0031]** The constriction device may include a plurality of separate constriction elements adapted to constrict any wall portions of a series of wall portions, respectively, of the tissue wall of the urethra, ureter, renal pelvis or bladder. The control device may control the constriction device to activate the constriction elements in random or in accordance with a predetermined sequence. In this case, the stimulation device includes stimulation elements positioned on the constriction elements, wherein the control device controls the stimulation device to activate the stimulation elements to stimulate any wall portions of the series of wall portions

constricted by said constriction elements to contract the urethra, ureter, renal pelvis or bladder to close the urinary passageway.

**[0032]** Alternatively, the control device controls the constriction device to activate the constriction elements to constrict all of the wall portions of the series of wall portions, and controls the stimulation device to activate the stimulation elements to stimulate any constricted wall portions in random or in accordance with a predetermined sequence to close the urinary passageway. The design of the constriction device in the form of a plurality of separate constriction elements makes possible to counteract growth of hard fibrosis where the constriction device is implanted.

#### Movement of urine in the urinary passageway

**[0033]** The apparatus of the invention can be used for actively moving the urine in the urinary passageway of a urinary overflow incontinent patient, as described in the embodiments of the invention listed below.

**[0034]** 1) The control device controls the constriction device to close the urinary passageway, either at an upstream end or a downstream end of the wall portion, and then controls the constriction device to constrict the remaining part of the wall portion to move the urine in the urinary passageway.

**[0035]** 1a) In accordance with a first alternative of the above noted embodiment (1), the control device controls the stimulation device to stimulate the wall portion as the constriction device constricts the remaining part of the wall portion.

**[0036]** 1b) In accordance with a second alternative, the constriction device is adapted to constrict the wall portion to restrict but not stop the flow of urine. The control device controls the stimulation device to stimulate the wall portion constricted by the constriction device to close the urinary passageway, either at an upstream end or a downstream end of the wall portion, and simultaneously controls the constriction device to increase the constriction of the wall portion to move the urine in the urinary passageway.

**[0037]** 2) The constriction device is adapted to constrict the wall portion to restrict or vary the flow of urine, and the control device controls the stimulation device to progressively stimulate the constricted wall portion, in the downstream or upstream direction of the urinary passageway, to cause progressive contraction of the wall portion to move the urine in the urinary passageway.

**[0038]** 3) The control device controls the constriction device to vary the constriction of the different areas of the wall portion, such that the wall portion is progressively constricted in the downstream or upstream direction of the urinary passageway to move the urine in the urinary passageway. The constriction device may include at least one elongated constriction element that extends along the wall portion, wherein the control device controls the elongated constriction element to progressively constrict the wall portion in the downstream or upstream direction of the lumen.

**[0039]** 3a) In accordance with a preferred alternative of the above noted embodiment (3), the control device controls the stimulation device to progressively stimulate the constricted wall portion to cause progressive contraction thereof in harmony with the progressive constriction of the wall portion performed by the constriction device. Where the constriction device includes at least one elongated constriction element the control device controls the elongated constriction element to progressively constrict the wall portion in the downstream or upstream direction of the urinary passageway. Suitably, the elongated constriction element comprises contact surfaces dimensioned to contact a length of the wall portion, when the constriction device constricts the wall portion, and the stimulation device comprises a plurality of stimulation elements distributed along the contact surfaces, such that the stimulation elements stimulate the different areas of the wall portion along the length of the wall portion, when the control device controls the stimulation device to stimulate the wall portion.

**[0040]** 4) The constriction device is adapted to constrict any one of a series of wall portions of the tissue wall to at least restrict the flow of urine. The control device controls the constriction device to successively constrict the wall portions of the series of wall portions to move the urine in the urinary passageway in a peristaltic manner.

**[0041]** 4a) In accordance with a first alternative of embodiment (4), the constriction device includes a plurality of constriction elements adapted to constrict the wall portions of the tissue wall, respectively. The control device controls the constriction device to activate the constriction elements one after the other, so that the wall portions of the series of wall portions are successively constricted along the urethra, ureter, renal pelvis or bladder, whereby the urine in the urinary passageway is moved.

**[0042]** 4b) In accordance with a second alternative of embodiment (4), the constriction device includes at least one constriction element that is moveable along the wall of the urethra, ureter, renal pelvis or bladder to successively constrict the wall portions of the series of wall portions, wherein the control device controls the constriction device to cyclically move the constriction element along the wall portions of the series of wall portions. Preferably, the constriction device comprises a plurality of constriction elements, each of which is moveable along the wall of the urethra, ureter, renal pelvis or bladder to successively constrict the wall portions of the series of wall portions, wherein the control device controls the constriction device to cyclically move the constriction elements one after the other along the wall portions of the series of wall portions. Specifically, the constriction device includes a rotor carrying the constriction elements, and the control device controls the rotor to rotate, such that each constriction element cyclically constricts the wall portions of the series of wall portions. Each constriction element suitably comprises a roller for rolling on the wall of the urethra, ureter, renal pelvis or bladder to constrict the latter.

**[0043]** 4c) In accordance with a preferred alternative of the above noted embodiment (4), the stimulation device stimulates any of the wall portions of the series of wall portions constricted by the constriction device, to close the urinary passageway. Where the constriction device includes at least one constriction element, the stimulation device suitably includes at least one stimulation element positioned on the constriction element for stimulating the wall portion constricted by the constriction element to close the urinary passageway.

**[0044]** Where the constriction device includes a plurality of constriction elements, the stimulation device suitably includes stimulation elements positioned on the constriction elements for stimulating the wall portions constricted by the constriction elements to close the urinary passageway.

**[0045]** 5) The constriction device is adapted to constrict any one of a series of wall portions of the tissue wall to restrict the flow of urine, wherein the constriction device includes a plurality of constriction elements adapted to constrict the wall portions of the tissue wall, respectively, and the stimulation device includes stimulation elements positioned on the constriction elements for stimulating the wall portions constricted by the constriction elements to close the urinary passageway. The control device controls the constriction device to activate the constriction elements to constrict the wall portions of the series of wall portions without completely closing the urinary

passageway, and controls the stimulation device to activate the stimulation elements to stimulate the wall portions one after the other, so that the wall portions of the series of wall portions are successively contracted along the urethra, ureter, renal pelvis or bladder to move the urine in the urinary passageway.

**[0046]** 6) The constriction device comprises a first constriction element for constricting the wall portion at an upstream end thereof, a second constriction element for constricting the wall portion at a downstream end thereof, and a third constriction element for constricting the wall portion between the upstream and downstream ends thereof. The control device controls the first, second and third constriction elements to constrict and release the wall portion independently of one another. More specifically, the control device controls the first or second constriction element to constrict the wall portion at the upstream or downstream end thereof to close the urinary passageway, and controls the third constriction element to constrict the wall portion between the upstream and downstream ends thereof, whereby the urine contained in the wall portion between the upstream and downstream ends thereof is moved downstream or upstream in the urinary passageway. Optionally, the control device controls the stimulation device to stimulate the wall portion between the upstream and downstream ends thereof, when the third constriction element constricts the wall portion.

**[0047]** 6a) In accordance with a first alternative, the control device controls the first constriction element to constrict the wall portion at the upstream end thereof to restrict the flow of urine and controls the stimulation device to stimulate the constricted wall portion at the upstream end to close the urinary passageway. With the urinary passageway closed at the upstream end of the constricted wall portion, the control device controls the third constriction element to constrict the wall portion between the upstream and downstream ends thereof, and optionally controls the stimulation device to simultaneously stimulate the wall portion as the latter is constricted by the third constriction element. As a result, the urine contained in the wall portion between the upstream and downstream ends thereof is moved downstream in the urinary passageway.

**[0048]** 6b) In accordance with a second alternative, the control device controls the second constriction element to constrict the wall portion at the downstream end thereof to restrict the flow of urine and controls the stimulation device to stimulate the constricted wall portion at the downstream end to close the urinary passageway.



With the urinary passageway closed at the downstream end of the constricted wall portion, the control device controls the third constriction element to constrict the wall portion between the upstream and downstream ends thereof, and optionally controls the stimulation device to simultaneously stimulate the wall portion as the latter is constricted by the third constriction element. As a result, the urine contained in the wall portion between the upstream and downstream ends thereof is moved upstream in the urinary passageway.

**[0049]** In any of the above noted embodiments (1) to (6b), the stimulation device may stimulate the wall portion with electric pulses.

**[0050]** The various solutions described above under the headline: "Flow restriction" to stop the flow of urine of the organ may also be used in any of the above noted embodiments (1a), (1b), (4a), (5), (6), (6a) and (6b).

#### Stimulation

**[0051]** When stimulating neural or muscular tissue there is a risk of injuring or deteriorating the tissue over time, if the stimulation is not properly performed. The apparatus of the present invention is designed to reduce or even eliminate that risk. Thus, in accordance with the present invention, the control device controls the stimulation device to intermittently stimulate different areas of the wall portion of the urethra, ureter, renal pelvis or bladder, such that at least two of the areas are stimulated at different points of time that is, the stimulation is shifted from one area to another area over time. In addition, the control device controls the stimulation device, such that an area of the different areas that currently is not stimulated has time to restore substantially normal blood circulation before the stimulation device stimulates the area again. Furthermore, the control device controls the stimulation device to stimulate each area during successive time periods, wherein each time period is short enough to maintain satisfactory blood circulation in the area until the lapse of the time period. This gives the advantage that the apparatus of the present invention enables continuous stimulation of the wall portion of the urethra, ureter, renal pelvis or bladder to achieve the desired flow control, while essentially maintaining over time the natural physical properties of the urethra, ureter, renal pelvis or bladder without risking injuring the urethra, ureter, renal pelvis or bladder.

**[0052]** Also, by physically changing the places of stimulation on the urethra, ureter, renal pelvis or bladder over time as described above it is possible to create an advantageous changing stimulation pattern on the urethra, ureter, renal pelvis or bladder, in order to achieve a desired flow control.

**[0053]** The control device may control the stimulation device to stimulate one or more of the areas of the wall portion at a time, for example by sequentially stimulating the different areas. Furthermore, the control device may control the stimulation device to cyclically propagate the stimulation of the areas along the wall portion, preferably in accordance with a determined stimulation pattern. To achieve the desired reaction of the tissue wall during the stimulation thereof, the control device may control the stimulation device to, preferably cyclically, vary the intensity of the stimulation of the wall portion.

**[0054]** In a preferred embodiment of the invention, the control device controls the stimulation device to intermittently stimulate the areas of the wall portion with pulses that preferably form pulse trains. At least a first area and a second area of the areas of the wall portion may be repeatedly stimulated with a first pulse train and a second pulse train, respectively, such that the first and second pulse trains over time are shifted relative to each other. For example, the first area may be stimulated with the first pulse train, while the second area is not stimulated with said second pulse train, and vice versa. Alternatively, the first and second pulse trains may be shifted relative to each other, such that the first and second pulse trains at least partially overlap each other.

**[0055]** The pulse trains can be configured in many different ways. Thus, the control device may control the stimulation device to vary the amplitudes of the pulses of the pulse trains, the duty cycle of the individual pulses of each pulse train, the width of each pulse of the pulse trains, the length of each pulse train, the repetition frequency of the pulses of the pulse trains, the repetition frequency of the pulse trains, the number of pulses of each pulse train, and/or the off time periods between the pulse trains. Several pulse trains of different configurations may be employed to achieve the desired effect.

**[0056]** In case the control device controls the stimulation device to vary the off time periods between pulse trains that stimulate the respective area of the wall portion, it is also possible to control each off time period between pulse trains to last long

enough to restore substantially normal blood circulation in the area when the latter is not stimulated during the off time periods.

### Electric Stimulation

**[0057]** In accordance with a preferred embodiment of the invention, the stimulation device is an electrically powered stimulation device that electrically stimulates the tissue wall portion of the patient's urethra, ureter, renal pelvis or bladder, preferably with electric pulses. This embodiment is particularly suited for applications in which the wall portion includes muscle fibers that react to electrical stimuli. In this embodiment, the control device controls the stimulation device to stimulate the wall portion with electric pulses preferably in the form of electric pulse trains, when the wall portion is in the constricted state, to cause contraction of the wall portion. Of course, the configuration of the electric pulse trains may be similar to the above described pulse trains and the control device may control the stimulation device to electrically stimulate the different areas of the wall of the urethra, ureter, renal pelvis or bladder in the same manner as described above.

**[0058]** The electric stimulation device suitably comprises at least one, preferably a plurality of electrical elements, such as electrodes, for engaging and stimulating the wall portion with electric pulses. Optionally, the electrical elements may be placed in a fixed orientation relative to one another. The control device controls the electric stimulation device to electrically energize the electrical elements, one at a time, or groups of electrical elements at a time. Preferably, the control device controls the electric stimulation device to cyclically energize each element with electric pulses. Optionally, the control device may control the stimulation device to energize the electrical elements, such that the electrical elements are energized one at a time in sequence, or such that a number or groups of the electrical elements are energized at the same time. Also, groups of electrical elements may be sequentially energized, either randomly or in accordance with a predetermined pattern.

**[0059]** The electrical elements may form any pattern of electrical elements. Preferably, the electrical elements form an elongate pattern of electrical elements, wherein the electrical elements are applicable on the patient's wall of the urethra, ureter, renal pelvis or bladder, such that the elongate pattern of electrical elements extends lengthwise along the wall of the urethra, ureter, renal pelvis or bladder, and

the elements about the respective areas of the wall portion. The elongate pattern of electrical elements may include one or more rows of electrical elements extending lengthwise along the wall of the urethra, ureter, renal pelvis or bladder. Each row of electrical elements may form a straight, helical or zig-zag path of electrical elements, or any form of path. The control device may control the stimulation device to successively energize the electrical elements longitudinally along the elongate pattern of electrical elements in a direction opposite to, or in the same direction as that of the flow of urine.

**[0060]** Optionally, the control device may control the stimulation device to successively energize the electrical elements from a position substantially at the center of the constricted wall portion towards both ends of the elongate pattern of electrical elements. When the urinary passageway is to be kept closed for a relatively long time, for example during the night, the control device may control the stimulation device to energize the electrical elements, such that energized electrical elements form two waves of energized electrical elements that simultaneously advance from the center of the constricted wall portion in two opposite directions towards both ends of the elongate pattern of electrical elements. Such waves of energized electrical elements can be repeated over and over again without harming the urethra, ureter, renal pelvis or bladder and without moving urine in any direction in the urinary passageway.

**[0061]** The control device suitably controls the stimulation device to energize the electrical elements, such that the electrical elements currently energized form at least one group of adjacent energized electrical elements. In accordance with a first alternative, the elements in the group of energized electrical elements form one path of energized electrical elements. The path of energized electrical elements may extend at least in part around the patient's urethra, ureter, renal pelvis or bladder. In a second alternative, the elements of the group of energized electrical elements may form two paths of energized electrical elements extending on mutual sides of the patient's urethra, ureter, renal pelvis or bladder, preferably substantially transverse to the flow direction in the urinary passageway. In a third alternative, the elements of the group of energized electrical elements may form more than two paths of energized electrical elements extending on different sides of the patient's urethra, ureter, renal pelvis or bladder, preferably substantially transverse to the flow direction in the patient's urinary passageway.

**[0062]** In accordance with a preferred embodiment of the invention, the electrical elements form a plurality of groups of elements, wherein the groups form a series of groups extending along the patient's urethra, ureter, renal pelvis or bladder in the flow direction in the urinary passageway. The electrical elements of each group of electrical elements may form a path of elements extending at least in part around the patient's urethra, ureter, renal pelvis or bladder. In a first alternative, the electrical elements of each group of electrical elements may form more than two paths of elements extending on different sides of the patient's urethra, ureter, renal pelvis or bladder, preferably substantially transverse to the flow direction in the patient's urinary passageway. The control device may control the stimulation device to energize the groups of electrical elements in the series of groups in random, or in accordance with a predetermined pattern. Alternatively, the control device may control the stimulation device to successively energize the groups of electrical elements in the series of groups in a direction opposite to, or in the same direction as that of, the flow in the patient's urinary passageway, or in both said directions starting from a position substantially at the center of the constricted wall portion. For example, groups of energized electrical elements may form advancing waves of energized electrical elements, as described above; that is, the control device may control the stimulation device to energize the groups of electrical elements, such that energized electrical elements form two waves of energized electrical elements that simultaneously advance from the center of the constricted wall portion in two opposite directions towards both ends of the elongate pattern of electrical elements.

**[0063]** A structure may be provided for holding the electrical elements in a fixed orientation. Although the structure may be separate from the constriction device, it is preferable that the structure is integrated in the constriction device, which is a practical design and facilitates implantation of the constriction and stimulation devices. Where the electrical elements form an elongate pattern of electrical elements, the structure may be applicable on the patient's urethra, ureter, renal pelvis or bladder such that the elongate pattern of electrical elements extends along the urethra, ureter, renal pelvis or bladder in the same direction as that of the flow in the patient's urinary passageway and the elements abut the respective areas of the wall portion of the urethra, ureter, renal pelvis or bladder.

### Thermal stimulation

**[0064]** In another embodiment of the invention, the stimulation device thermally stimulates the wall portion of the urethra, ureter, renal pelvis or bladder. Thus, the control device may control the stimulation device to cool the wall portion, when the wall portion is constricted, to cause contraction of the wall portion. For example, the constriction device may constrict the wall portion to at least restrict the flow of urine, and the control device may control the stimulation device to cool the constricted wall portion to cause contraction thereof, such that the flow of urine is at least further restricted, or further restricted but not stopped, or stopped. Alternatively, the control device may control the stimulation device to heat the wall portion, when the wall portion is constricted and contracted, to cause expansion of the wall portion. Where applicable, thermal stimulation may be practised in any of the embodiments of the present invention, and the thermal stimulation may be controlled in response to various sensors, for example strain, motion or pressure sensors.

### Sensor Controlled Constriction and/or Stimulation Device

**[0065]** As mentioned above, the apparatus may comprise at least one implantable sensor, wherein the control device controls the constriction device and/or the stimulation device in response to signals from the sensor. Generally, the sensor directly or indirectly senses at least one physical parameter of the patient, or at least one functional parameter of the apparatus, or at least one functional parameter of a medical implant in the patient.

**[0066]** Many different kinds of sensor for sensing physical parameters may be used. For example motion sensors for sensing motion, *i.e.* natural contractions, such as bladder contractions, pressure sensors for sensing pressure in the urethra, ureter, renal pelvis or bladder, strain sensors for sensing strain of the urethra, ureter, renal pelvis or bladder, flow sensors for sensing flow of urine, spectro-photometrical sensors, Ph-sensors for sensing acidity or alkalinity of the urine in the urinary passageway, oxygen-sensors sensors for sensing the oxygen content of the urine in the urinary passageway, or sensors for sensing the distribution of the stimulation on the stimulated urethra, ureter, renal pelvis or bladder. Any conceivable sensors for sensing any other kind of useful physical parameter may be used.

**[0067]** Many different kinds of sensors that sense functional parameters of the apparatus may also be used for the control of the constriction device and/or the stimulation device. For example sensors for sensing electric parameters of implanted electric components of the apparatus, or sensors for sensing the performance of implanted motors of the apparatus.

**[0068]** The sensor may comprise a pressure sensor for sensing as the physical parameter a pressure in the patient's body that relates to the pressure in the urinary passageway, wherein the control device controls the constriction device and/or stimulation device to change the constriction of the patient's wall portion of the urethra, ureter, renal pelvis or bladder in response to the pressure sensor sensing a predetermined value of measured pressure.

**[0069]** Alternatively, or in combination with the pressure sensor, a position sensor may be provided for sensing as the physical parameter the orientation of the patient with respect to the horizontal. The position sensor may be a biocompatible version of what is shown in U.S. patents 4 942 668 and 5 900 909. For example, the control device may control the constriction device and/or stimulation device to change the constriction of the patient's wall portion in response to the position sensor sensing that the patient has assumed a substantially horizontal orientation, *i.e.* that the patient is lying down.

**[0070]** The above described sensors may be used in any of the embodiments of the invention, where applicable.

**[0071]** The control device may control the constriction device and/or stimulation device to change the constriction of the patient's wall portion of the urethra, ureter, renal pelvis or bladder in response to the time of day. For that purpose the control device may include a clock mechanism for controlling the constriction device and/or stimulation device to change the constriction of the patient's wall portion to increase or decrease the influence on the flow of urine during different time periods of the day. In case a sensor of any of the above-described types for sensing a physical or functional parameter is provided, either the clock mechanism is used for controlling the constriction device and/or stimulation device provided that the parameter sensed by the sensor does not override the clock mechanism, or the sensor is used for controlling the constriction device and/or stimulation device provided that the clock mechanism does not override the sensor. Suitably, the control device produces an

indication, such as a sound signal or displayed information, in response to signals from the sensor.

**[0072]** The control device may comprise an implantable internal control unit that directly controls the constriction device and/or stimulation device in response to signals from the sensor. The control device may further comprise a wireless remote control adapted to set control parameters of the internal control unit from outside the patient without mechanically penetrating the patient. At least one of the control parameters, which is settable by the wireless remote control, is the physical or functional parameter. Suitably, the internal control unit includes the above mentioned clock mechanism, wherein the wireless remote control also is adapted to set the clock mechanism.

**[0073]** Alternatively, the control device may comprise an external control unit outside the patient's body for controlling the constriction device and/or stimulation device in response to signals from the sensor.

#### Adjustable Constriction Device

**[0074]** In several alternative embodiments of the invention, the constriction device is adjustable. In these embodiments, there is an operation device for operating the adjustable constriction device to change the constriction of the patient's tissue wall portion of the urethra, ureter, renal pelvis or bladder, and the constriction and stimulation devices form a constriction/stimulation unit. Preferably, the constriction and stimulation devices of the constriction/stimulation unit are integrated in a single piece suitable for implantation. The constriction device of the unit comprises contact surfaces dimensioned to contact a length of a tissue wall portion of the urethra, ureter, renal pelvis or bladder, and the stimulation device of the unit comprises a plurality of stimulation elements provided on and distributed along the contact surfaces. When the control device controls the stimulation device to stimulate the wall portion, the stimulation elements stimulate different areas of the wall portion along the length of the wall portion. The stimulation elements preferably comprise electric elements, as described above, for stimulating the wall portion with electric pulses. However, in most of the embodiments of the present invention, other kinds of stimulations could be suitable to employ.



**[0075]** The operation device operates the adjustable constriction device of the constriction/stimulation unit in a manner that depends on the design of the constriction device, as will be explained by the following examples of embodiments.

1) The constriction device comprises at least two elongated clamping elements having the contact surfaces and extending along the wall portion on different sides of the urethra, ureter, renal pelvis or bladder, and the operation device operates the clamping elements to clamp the wall portion between the clamping elements to constrict the wall portion of the urethra, ureter, renal pelvis or bladder.

**[0076]** 2) The constriction device comprises one elongate clamping element having the contact surfaces and extending along the wall portion on one side of the urethra, ureter, renal pelvis or bladder, and the operation device operates the clamping element to clamp the wall portion between the clamping element and the bone or tissue of the patient to constrict the wall portion.

**[0077]** 3) The constriction device comprises at least two engagement elements having the contact surfaces and positioned on different sides of the urethra, ureter, renal pelvis or bladder, and the operation device rotates the engagement elements, such that the engagement elements engage and constrict the wall portion of the urethra, ureter, renal pelvis or bladder.

**[0078]** 4) The constriction device comprises at least two articulated clamping elements having the contact surfaces and positioned on different sides of the urethra, ureter, renal pelvis or bladder, and the operation device moves the clamping elements towards each other to clamp the wall portion of the urethra, ureter, renal pelvis or bladder between the clamping elements, to constrict the wall portion.

**[0079]** 5) The constriction device comprises at least two separate clamping elements having the contact surfaces, at least one of the clamping elements being pivoted, such that it may turn in a plane in which the loop of the constriction member extends, and the operation device turns the pivoted clamping element to change the size of the constriction opening.

**[0080]** 6) The constriction device comprises at least one elongated constriction member having the contact surfaces, and forming means for forming the constriction member into at least a substantially closed loop around the urethra, ureter, renal pelvis or bladder, wherein the loop defines a constriction opening. The operation device operates the constriction member in the loop to change the size of the constriction opening.

**[0081]** 6a) The elongated constriction member comprises a belt having the contact surfaces, and the operation device operates the belt to change the longitudinal extension of the belt in the loop to change the size of the constriction opening. The forming means may form the constriction member or belt into a loop having at least one predetermined size.

**[0082]** 6b) The elongated constriction member is operable to change the size of the constriction opening, such that the outer circumferential confinement surface of the constriction device is changed, or, alternatively, is unchanged.

**[0083]** 6c) The elongated constriction member is elastic and varies in thickness as seen in a cross-section there through, and is operable to turn around the longitudinal extension of the constriction member.

**[0084]** 6d) The elongated constriction member comprises two substantially or partly semi-circular frame elements having the contact surfaces and hinged together, such that the semi-circular elements are swingable relative to each other from a fully open state in which they substantially or partly form a circle to a fully folded state in which they substantially form a semi-circle.

**[0085]** 7) The constriction device is adapted to bend the wall portion of the urethra, ureter, renal pelvis or bladder to constrict the latter.

**[0086]** In the above noted embodiments (1) to (7), it is important that the constriction device is designed to constrict said length of the tissue wall portion of the patient's urethra, ureter, renal pelvis or bladder. For this purpose, the constriction device may include two or more of the described constriction elements/members to be applied in a row along said length of the wall portion, wherein said row extends in the direction of flow of urine of the organ. Preferably, such constriction elements/members are non-inflatable and mechanically operable or adjustable.

**[0087]** In the above noted embodiments (1) to (7), the operation device may either mechanically or hydraulically adjust the constriction device of the constriction/stimulation unit. Also, the operation device may comprise an electrically powered operation device for operating the constriction device. For many applications of the present invention, the operation device suitably operates the constriction device, such that the through-flow area of the lumen assumes a size in the constricted state that enables the stimulation device to contract the wall portion such that the flow of urine is stopped.

### Mechanical operation

**[0088]** Where the operation device mechanically operates the constriction device of the constriction/stimulation unit, it may be non-inflatable. Furthermore, the operation device may comprise a servo system, which may include a gearbox. The term “servo system” encompasses the normal definition of a servo mechanism, *i.e.*, an automatic device that controls large amounts of power by means of very small amounts of power, but may alternatively or additionally encompass the definition of a mechanism that transfers a weak force acting on a moving element having a long stroke into a strong force acting on another moving element having a short stroke. Preferably, the operation device operates the constriction device in a non-magnetic and/or non-manual manner. A motor may be operatively connected to the operation device. The operation device may be operable to perform at least one reversible function and the motor may be capable of reversing the function.

### Hydraulic Operation

**[0089]** Where the operation device hydraulically operates the constriction device of the constriction/stimulation unit, it includes hydraulic means for adjusting the constriction device.

**[0090]** In an embodiment of the invention, the hydraulic means comprises a reservoir and an expandable/contractible cavity in the constriction device, wherein the operation device distributes hydraulic fluid from the reservoir to expand the cavity, and distributes hydraulic fluid from the cavity to the reservoir to contract the cavity. The cavity may be defined by a balloon of the constriction device that abuts the tissue wall portion of the patient's urethra, ureter, renal pelvis or bladder, so that the patient's wall portion is constricted upon expansion of the cavity and released upon contraction of the cavity.

**[0091]** Alternatively, the cavity may be defined by a bellows that displaces a relatively large contraction element of the constriction device, for example a large balloon that abuts the wall portion of the urethra, ureter, renal pelvis or bladder, so that the patient's wall portion is constricted upon contraction of the bellows and released upon expansion of the bellows. Thus, a relatively small addition of hydraulic fluid to the bellows causes a relatively large increase in the constriction of the wall portion.

Such a bellows may also be replaced by a suitably designed piston/cylinder mechanism.

**[0092]** Where the hydraulic means comprises a cavity in the constriction device, the apparatus of the invention can be designed in accordance with the options listed below.

**[0093]** 1) The reservoir comprises first and second wall portions, and the operation device displaces the first and second wall portions relative to each other to change the volume of the reservoir, such that fluid is distributed from the reservoir to the cavity, or from the cavity to the reservoir.

1a) The first and second wall portions of the reservoir are displaceable relative to each other by at least one of a magnetic device, a hydraulic device or an electric control device.

2) The operation device comprises a pump for pumping fluid between the reservoir and the cavity.

2a) The pump comprises a first activation member for activating the pump to pump fluid from the reservoir to the cavity and a second activation member for activating the pump to pump fluid from the cavity to the reservoir.

2a1) The first and second activation members are operable by manual manipulation thereof.

2a2) At least one of the activation members operates when subjected to an external predetermined pressure.

2a3) At least one of the first and second activating members is operable by magnetic means, hydraulic means, or electric control means.

2b) The apparatus comprises a fluid conduit between the pump and the cavity, wherein the reservoir forms part of the conduit. The conduit and pump are devoid of any non-return valve. The reservoir forms a fluid chamber with a variable volume, and the pump distributes fluid from the chamber to the cavity by a reduction in the volume of the chamber and withdraws fluid from the cavity by an expansion of the volume of the chamber. The apparatus further comprises a motor for driving the pump, wherein the pump comprises a movable wall of the reservoir for changing the volume of the chamber.

**[0094]** In all of the above noted embodiments 1 to 2b where the hydraulic means comprises an expandable cavity in the constriction device, the cavity can be exchanged by a cylinder/piston mechanism for adjusting the constriction device. In

this case, the operation device distributes hydraulic fluid between the reservoir and the cylinder/piston mechanism to adjust the constriction device.

**[0095]** In a special embodiment of the invention, the operation device comprises a reverse servo operatively connected to the hydraulic means. The term "reverse servo" is to be understood as a mechanism that transfers a strong force acting on a moving element having a short stroke into a weak force acting on another moving element having a long stroke; *i.e.*, the reverse function of a normal servo mechanism. Thus, minor changes in the amount of fluid in a smaller reservoir could be transferred by the reverse servo into major changes in the amount of fluid in a larger reservoir. The reverse servo is particularly suited for manual operation thereof.

**[0096]** Preferably, the reverse servo comprises an expandable servo reservoir containing servo fluid and a fluid supply reservoir hydraulically connected to the servo reservoir to form a closed conduit system for the servo fluid. The expandable servo reservoir has first and second wall portions, which are displaceable relative to each other in response to a change in the volume of the expandable servo reservoir.

**[0097]** In accordance with a first alternative, the first and second wall portions of the servo reservoir are operatively connected to the hydraulic means. The reverse servo distributes fluid between the fluid supply reservoir and the expandable servo reservoir to change the volume of the servo reservoir, whereby the hydraulic means is operated to adjust the constriction device.

**[0098]** In accordance with a second alternative, there is provided an implantable main reservoir containing a predetermined amount of hydraulic fluid, wherein the reverse servo is operable to distribute hydraulic fluid between the main reservoir and the hydraulic means to adjust the constriction device. More specifically, the main reservoir is provided with first and second wall portions operatively connected to the first and second wall portions of the expandable servo reservoir, such that the volume of the main reservoir is changed when the volume of the expandable servo reservoir is changed. Thus, when the reverse servo distributes servo fluid between the fluid supply reservoir and the expandable servo reservoir to change the volume of the main reservoir, hydraulic fluid is distributed from the main reservoir to the hydraulic means, or from the hydraulic means to the main reservoir. Advantageously, the servo and main reservoirs are dimensioned, such that when the volume of the servo reservoir is changed by a relatively small amount of servo fluid, the volume of the main reservoir is changed by a relatively large amount of hydraulic fluid.

**[0099]** In both of the above-described alternatives, the fluid supply reservoir may have first and second wall portions, which are displaceable relative to each other to change the volume of the fluid supply reservoir to distribute servo fluid between the fluid supply reservoir and the expandable servo reservoir. The first and second wall portions of the fluid supply reservoir may be displaceable relative to each other by manual manipulation, a magnetic device, a hydraulic device, or an electric control device to change the volume of the fluid supply reservoir to distribute servo fluid between the fluid supply reservoir and the expandable servo reservoir.

**[00100]** In all of the above noted embodiments 1 to 2b where the hydraulic means comprises an expandable cavity in the constriction device, or in embodiments where the hydraulic means comprises a hydraulically operable mechanical construction, the operation device may include the reverse servo described above. In a further embodiment of the invention, the hydraulic means include first and second hydraulically interconnected expandable/contractible reservoirs. The first reservoir is operatively connected to the constriction device, such that the constriction device changes the constriction of the patient's wall portion upon expansion or contraction of the first reservoir. By changing the volume of the second reservoir hydraulic fluid is distributed between the two reservoirs, so that the first reservoir is either expanded or contracted. This embodiment requires no non-return valve in the fluid communication conduits between the two reservoirs, which is beneficial to long-term operation of the hydraulic means.

**[00101]** Alternatively, the hydraulic means may include first and second hydraulically interconnected piston/cylinder mechanisms instead of the first and second reservoirs described above. The first piston/cylinder mechanism is operatively connected to the constriction device, such that the constriction device changes the constriction of the patient's wall portion upon operation of the first piston/cylinder mechanism. By operating the second piston/cylinder mechanism hydraulic fluid is distributed between the two piston/cylinder mechanisms, so that the first piston/cylinder mechanism adjusts the constriction device.

**[00102]** Where the constriction device does not include an expandable/contractible cavity, the constriction device may comprise at least two elongated clamping elements having the above-mentioned contact surfaces and extending along the wall portion on different sides of the urethra, ureter, renal pelvis or bladder. The hydraulic means, which may include the reverse servo described

above, hydraulically moves the elongated clamping elements towards the wall portion to constrict the wall portion. For example, the constriction device may have hydraulic chambers in which the clamping elements slide back and forth, and the hydraulic means may also include a pump and an implantable reservoir containing hydraulic fluid. The pump distributes hydraulic fluid from the reservoir to the chambers to move the clamping elements against the wall portion, and distributes hydraulic fluid from the chambers to the reservoir to move the clamping elements away from the wall portion.

#### Design of control device

**[00103]** The control device suitably controls the constriction/stimulation unit from outside the patient's body. Preferably, the control device is operable by the patient. For example, the control device may comprise a manually operable switch for switching on and off the constriction/stimulation unit, wherein the switch is adapted for subcutaneous implantation in the patient to be manually or magnetically operated from outside the patient's body. Alternatively, the control device may comprise a hand-held wireless remote control, which is conveniently operable by the patient to switch on and off the constriction/stimulation unit. The wireless remote control may also be designed for application on the patient's body like a wristwatch. Such a wristwatch type of remote control may emit a control signal that follows the patient's body to implanted signal responsive means of the apparatus.

**[00104]** Where the control device wirelessly controls the constriction/stimulation unit from outside the patient's body, the wireless control function is preferably performed in a non-magnetic manner, *i.e.*, the control device controls the constriction device of the constriction/stimulation unit in a non-magnetic manner. The patient may use the remote control to control the constriction/stimulation unit to adjust the stimulation intensity and/or adjust the constriction of the wall portion of the urethra, ureter, renal pelvis or bladder. The wireless remote control may comprise at least one external signal transmitter or transceiver and at least one internal signal receiver or transceiver implantable in the patient.

**[00105]** The wireless remote control preferably transmits at least one wireless control signal for controlling the constriction/stimulation unit. The control signal may comprise a frequency, amplitude, phase modulated signal or a combination thereof,

and may be an analogue or a digital signal, or a combination of an analogue and digital signal. The remote control may transmit an electromagnetic carrier wave signal for carrying the digital or analogue control signal. Also the carrier signal may comprise digital, analogue or a combination of digital and analogue signals.

**[00106]** Any of the above control signals may comprise wave signals, for example a sound wave signal, an ultrasound wave signal, an electromagnetic wave signal, an infrared light signal, a visible light signal, an ultra violet light signal, a laser light signal, a microwave signal, a radio wave signal, an x-ray radiation signal or a gamma radiation signal. Alternatively, the control signal may comprise an electric or magnetic field, or a combined electric and magnetic field.

**[00107]** As mentioned above, the control signal may follow the patient's body to implanted signal responsive means of the apparatus.

**[00108]** The control device may include a programmable internal control unit, such as a microprocessor, implantable in the patient for controlling the constriction/stimulation unit. The control device may further include an external control unit intended to be outside the patient's body, wherein the internal control unit is programmable by the external control unit. For example, the internal control unit may be programmable for controlling the constriction/stimulation unit over time, suitably in accordance with an activity schedule program. The apparatus of the invention may comprise an external data communicator and an implantable internal data communicator communicating with the external data communicator, wherein the internal communicator feeds data related to the constriction/stimulation unit back to the external data communicator or the external data communicator feeds data to the internal data communicator.

#### Source of Energy

**[00109]** The present invention also presents a solution for supplying energy for use in connection with the operation of the constriction/stimulation unit. Thus, in a broad sense, the present invention provides an apparatus for controlling the flow of urine in the urinary passageway formed by the tissue wall of the patient's urethra, ureter, renal pelvis or bladder, wherein the apparatus comprises an implantable constriction device for gently constricting a portion of the tissue wall to influence the flow of urine, a stimulation device for intermittently and individually stimulating



different areas of the wall portion, as the constriction device constricts the wall portion, to cause contraction of the wall portion to further influence the flow of urine, wherein the constriction and stimulation devices form an operable constriction/stimulation unit, a source of energy, and a control device operable from outside the patient's body to control the source of energy to release energy for use in connection with the operation of the constriction/stimulation unit. In a simple form of the invention, the source of energy, such as a battery or accumulator, is implantable in the patient's body.

### Transmission of Wireless Energy

**[00110]** In a more sophisticated form of the invention, which is preferable, the source of energy is external to the patient's body and the control device controls the external source of energy to release wireless energy. In this sophisticated form of the invention, the apparatus comprises an energy-transmission device that transmits the released wireless energy from outside the patient's body to inside the patient's body. Among many things the wireless energy may comprise electromagnetic energy, an electric field, an electromagnetic field or a magnetic field, or a combination thereof, or electromagnetic waves. The energy-transmission device may transmit wireless energy for direct use in connection with the operation of the constriction/stimulation unit, as the wireless energy is being transmitted. For example, where an electric motor or pump operates the constriction device, wireless energy in the form of a magnetic or an electromagnetic field may be used for direct power of the motor or pump.

**[00111]** Thus, the motor or pump is running directly during transmission of the wireless energy. This may be achieved in two different ways: a) using a transforming device implanted in the patient to transform the wireless energy into energy of a different form, preferably electric energy, and powering the motor or pump with the transformed energy, or b) using the wirelessly transmitted energy to directly power the motor or pump. Preferably wireless energy in the form of an electromagnetic or magnetic field is used to directly influence specific components of the motor or pump to create kinetic energy for driving the motor or pump. Such components may include coils integrated in the motor or pump, or materials influenced by magnetic fields, or permanent magnets, wherein the magnetic or electromagnetic field

influences the coils to generate a current for driving the motor or pump, or influences the material or permanent magnets to create kinetic energy for driving the motor or pump.

**[00112]** Preferably, the energy-transmission device transmits energy by at least one wireless signal, suitably a wave signal. The wave signal may comprise an electromagnetic wave signal including one of an infrared light signal, a visible light signal, an ultra violet light signal, a laser signal, a microwave signal, a radio wave signal, an x-ray radiation signal, and a gamma radiation signal. Alternatively, the wave signal may comprise a sound or ultrasound wave signal. The wireless signal may be a digital or analogue signal, or a combination of a digital and analogue signal.

### Transforming Wireless Energy

**[00113]** In accordance with a particular embodiment of the invention, an implantable energy-transforming device is provided for transforming wireless energy of a first form transmitted by the energy-transmission device into energy of a second form, which typically is different from the energy of the first form. The constriction/stimulation unit is operable in response to the energy of the second form. For example, the wireless energy of the first form may comprise sound waves, whereas the energy of the second form may comprise electric energy. In this case, the energy-transforming device may include a piezo-electric element for transforming the sound waves into electric energy. Optionally, one of the energy of the first form and the energy of the second form may comprise magnetic energy, kinetic energy, sound energy, chemical energy, radiant energy, electromagnetic energy, photo energy, nuclear energy or thermal energy. Preferably, one of the energy of the first form and the energy of the second form is non-magnetic, non-kinetic, non-chemical, non-sonic, non-nuclear or non-thermal.

**[00114]** The energy-transforming device may function differently from or similar to the energy-transmission device. In a special embodiment, the energy-transforming device comprises at least one element, such as at least one semiconductor, having a positive region and a negative region, when exposed to the energy of the first form transmitted by the energy-transmission device, wherein the element is capable of creating an energy field between the positive and negative regions, and the energy

field produces the energy of the second form. More specifically, the element may comprise an electrical junction element, which is capable of inducing an electric field between the positive and negative regions when exposed to the energy of the first form transmitted by the energy-transmission device, whereby the energy of the second form comprises electric energy.

**[00115]** The energy-transforming device may transform the energy of the first form directly or indirectly into the energy of the second form. An implantable motor or pump for operating the constriction device of the constriction/stimulation unit may be provided, wherein the motor or pump is powered by the energy of the second form. The constriction device may be operable to perform at least one reversible function and the motor may be capable of reversing the function. For example, the control device may shift polarity of the energy of the second form to reverse the motor.

**[00116]** The energy-transforming device may directly power the motor or pump with the transformed energy, as the energy of the second form is being transformed from the energy of the first form. Preferably, the energy-transforming device directly operates the constriction/stimulation unit with the energy of the second form in a non-magnetic, non-thermal or non-mechanical manner.

**[00117]** Normally, the constriction/stimulation unit comprises electric components that are energized with electrical energy. Other implantable electric components of the apparatus may be at least one voltage level guard or at least one constant current guard. Therefore, the energy-transforming device may transform the energy of the first form into a direct current or pulsating direct current, or a combination of a direct current and pulsating direct current. Alternatively, the energy-transforming device may transform the energy of the first form into an alternating current or a combination of a direct and alternating current.

**[00118]** The apparatus of the invention may comprise an internal source of energy implantable in the patient for supplying energy for the operation of the constriction/stimulation unit. The apparatus may further comprise an implantable switch operable to switch from an "off" mode, in which the internal source of energy is not in use, to an "on" mode, in which the internal source of energy supplies energy for the operation of the constriction/stimulation unit, and/or for energizing implanted electronic components of the apparatus. The switch may be operable by the energy of the first form transmitted by the energy-transmission device or by the energy of

the second form supplied by the energy-transforming device. The described switch arrangement reduces power consumption of the apparatus between operations.

**[00119]** The internal source of energy may store the energy of the second form supplied by the energy-transforming device. In this case, the internal source of energy suitably comprises an accumulator, such as at least one capacitor or at least one rechargeable battery, or a combination of at least one capacitor and at least one rechargeable battery. Where the internal source of energy is a rechargeable battery it may be charged only at times convenient for the patient, for example when the patient is sleeping. Alternatively, the internal source of energy may supply energy for the operation of the constriction/stimulation unit but not be used for storing the energy of the second form. In this alternative, the internal source of energy may be a battery and the switch described above may or may not be provided.

**[00120]** Suitably, the apparatus of the invention comprises an implantable stabilizer for stabilizing the energy of the second form. Where the energy of the second form is electric energy the stabilizer suitably comprises at least one capacitor.

**[00121]** The energy-transforming device may be designed for implantation subcutaneously in the abdomen, thorax or cephalic region of the patient. Alternatively, it may be designed for implantation in an orifice of the patient's body and under the mucosa or intramuscularly outside the mucosa of the orifice.

**[00122]** Although the constriction/stimulation unit in the embodiments described above is designed as a single piece, which is most practical for implantation, it should be noted that as an alternative the constriction device and stimulation device could be designed as separate pieces. Any one of the constriction and stimulation units described above may alternatively be replaced by two or more separate constriction/stimulation elements, which are controlled independently of one another.

**[00123]** In accordance with another aspect of the present invention, there is provided an apparatus for controlling the flow of urine in the urethra, ureter, renal pelvis or urine bladder of a patient, the apparatus comprising an implantable stimulation device for stimulating at least one portion of the tissue wall of the patient's urethra, ureter, renal pelvis or urine bladder, and a control device for controlling the stimulation device to stimulate the wall portion to cause contraction of the wall portion to influence the flow of urine in the urethra, ureter, renal pelvis or urine bladder. Thus, for some individuals it may suffice to stimulate the urethra,

ureter, renal pelvis or urine bladder to achieve continence or to restore bladder function, whereby there is no need for applying the constriction device. Where applicable, any of the embodiments outlined in the appended claims could be applied in this apparatus that only includes the stimulation device.

**[00124]** The present invention also provides a method for using an apparatus as described above to control the flow of urine in the urinary passageway formed by the tissue wall of a patient's urethra, ureter, renal pelvis or bladder, the method comprising:

- providing a wireless remote control adapted to control the constriction device and/or stimulation device from outside the patient's body, and
- operating the wireless remote control by the patient, when the patient wants to influence the flow of urine in the lumen.

#### BRIEF DESCRIPTION OF THE DRAWINGS

**[00125]** FIGURES 1A, 1B, 1C, 1D and 1E schematically illustrate different states of operation of a general embodiment of an apparatus according to the present invention.

**[00126]** FIGURES 1F, 1G and 1H illustrate different states of operation of a modification of the general embodiment.

**[00127]** FIGURES 1I, 1K and 1L illustrate an alternative mode of operation of the modification of the general embodiment.

**[00128]** FIGURE 2 is a longitudinal cross-section of a preferred embodiment of the apparatus according to the invention including a constriction device and an electric stimulation device.

**[00129]** FIGURE 3 is a cross-section along line III-III in FIGURE 2.

**[00130]** FIGURE 4 is the same cross-section shown in FIGURE 3, but with the apparatus in a different state of operation.

**[00131]** FIGURES 5A, 5B and 5C are cross-sections of the embodiment of FIGURE 2 showing different states of operations with the apparatus applied on a tissue wall of a patient's urethra, ureter, renal pelvis or bladder.

**[00132]** FIGURES 6A, 6B and 6C are cross-sections of a modification of the embodiment of FIGURE 2 showing different states of operations with the apparatus applied on a tissue wall of a patient's urethra, ureter, renal pelvis or bladder.

**[00133]** FIGURES 7A and 7B show different steps of an electric stimulation mode performed by the apparatus of FIGURE 2, while the apparatus is constricting a tissue wall of a patient's urethra, ureter, renal pelvis or bladder.

**[00134]** FIGURE 8A is a pulse/time diagram showing electric stimulation pulses generated by the apparatus of the invention for stimulating a tissue wall of a patient's urethra, ureter, renal pelvis or bladder.

**[00135]** FIGURE 8B is pulse/time diagram showing a modification of the electric stimulation shown in FIGURE 8A, in which pulses of mixed frequencies and/or amplitudes are employed.

**[00136]** FIGURES 9A and 9B show two pulse/time diagrams, respectively, representing electric stimulation of two different areas of the tissue wall with pulses forming pulse trains.

**[00137]** FIGURES 10A and 10B show the pulse/time diagrams of FIGURES 9A and 9B with modified pulse trains.

**[00138]** FIGURE 11A is a longitudinal cross-section of an embodiment of the apparatus of the invention including a thermal stimulation device, wherein the apparatus is constricting a tissue wall of a patient's urethra, ureter, renal pelvis or bladder.

**[00139]** FIGURE 11B is the same embodiment of FIGURE 11A with the thermal stimulation device activated.

**[00140]** FIGURE 12A is a schematic view of hydraulic operation means suited for operating the constriction device of the embodiments of FIGURES 2-11.

**[00141]** FIGURE 12B shows the embodiment of FIGURE 12A with the constriction device constricting a tissue wall of a patient's urethra, ureter, renal pelvis or bladder.

**[00142]** FIGURE 13A is a schematic view of mechanical operation means suited for operating the constriction device of the embodiments of FIGURES 2-11.

**[00143]** FIGURE 13B shows the embodiment of FIGURE 13A with the constriction device constricting a tissue wall of a patient's urethra, ureter, renal pelvis or bladder.

**[00144]** FIGURE 13C shows a modification of the embodiment of FIGURE 13B.

**[00145]** FIGURE 14A illustrates the apparatus of the invention applied on the urethra of a urinary incontinent patient.

**[00146]** FIGURE 14B illustrates the apparatus of the invention applied on the ureter of a urinary incontinent patient.

**[00147]** FIGURE 14C illustrates the apparatus of the invention applied on the urinary bladder.

**[00148]** FIGURE 14D illustrates the embodiment of FIGURE 14C combined with the embodiment shown in FIGURE 14A.

**[00149]** FIGURE 15 is a schematic sectional view of a mechanically operable non-inflatable constriction device for use in accordance with the invention.

**[00150]** FIGURES 16 and 17 are cross-sectional views taken along the lines XVI-XVI and XVII-XVII, respectively, of FIGURE 15.

**[00151]** FIGURE 18 schematically shows an alternative design of the embodiment of FIGURE 15;

**[00152]** FIGURE 19 schematically illustrates a motor arrangement for the design according to FIGURE 18;

**[00153]** FIGURES 20 and 21 are schematic sectional views of two alternative designs of non-inflatable constriction devices of the invention.

**[00154]** FIGURES 22 and 23 illustrate a fully open and a reduced constriction opening, respectively, of the embodiment of FIGURE 21;

**[00155]** FIGURE 24 is a schematic view of a further alternative design of a non-inflatable constriction device of the invention.

**[00156]** FIGURES 25 and 26 illustrate a fully open and a reduced constriction opening, respectively, of the embodiment of FIGURE 24;

**[00157]** FIGURE 27 is a schematic view of another alternative design of a non-inflatable constriction device of the invention.

**[00158]** FIGURES 28 and 29 are schematic sectional views, respectively, of yet another alternative design of a non-inflatable constriction device of the invention.

**[00159]** FIGURE 30A is a schematic view of a hydraulically operable inflatable constriction device for use in accordance with the invention.

**[00160]** FIGURE 30B is the same embodiment shown in FIGURE 30A with the constriction device inflated.

**[00161]** FIGURES 31A, 31B, 31C and 31D are block diagrams illustrating four different principles for hydraulic operation of the constriction device shown in FIGURE 30A.

**[00162]** FIGURE 32 is a cross-sectional view of a reservoir having a variable volume controlled by a remote control motor.

**[00163]** FIGURES 33A and 33B are perspective views of a reverse servo in accordance with a particular embodiment of the hydraulic operation principle shown in FIGURE 31C.

**[00164]** FIGURE 34 is a schematic view of another hydraulically operable constriction device for use in accordance with the invention.

**[00165]** FIGURE 35A illustrates the constriction device of FIGURE 34 in a constricted state.

**[00166]** FIGURE 35B illustrates the constriction device of FIGURE 34 in a released state.

**[00167]** FIGURES 36A – 36E schematically illustrate different operation stages of an embodiment of the invention, in which a constriction device and a stimulation device co-operate to move the urine in the urinary passageway of a patient's urethra, ureter, renal pelvis or bladder.

**[00168]** FIGURE 37 is a schematic block diagram illustrating a general embodiment of the apparatus of the invention, in which energy is transferred to energy consuming components of the apparatus implanted in the patient.

**[00169]** FIGURES 38 to 49 are schematic block diagrams illustrating twelve embodiments, respectively, based on the general embodiment shown in FIGURE 37, wherein wireless energy is transmitted from outside a patient's body to energy consuming components of the apparatus implanted in the patient.

**[00170]** FIGURE 50 illustrates an energy-transforming device in the form of an electrical junction element for use in the apparatus of the present invention.

**[00171]** FIGURE 51 is a block diagram illustrating control components of an embodiment of the invention.

**[00172]** FIGURE 52 is a schematic view of exemplary circuitry of an embodiment of the invention, in which wireless energy is transformed into a current.

**[00173]** FIGURES 53A – 53C schematically illustrate different operation stages of another embodiment of the invention of the type shown in FIGURE 2, in which a constriction device and a stimulation device co-operate to move the urine in the urinary passageway of a patient's urethra, ureter, renal pelvis or bladder.

**[00174]** FIGURES 54A – 54B schematically illustrate different operation stages of another embodiment of the invention of the type shown in FIGURES 36A – 36E, in



which a constriction device and a stimulation device co-operate to move the urine in the lumen of a patient's urethra, ureter, renal pelvis or bladder.

**[00175]** FIGURE 55A is a schematic view of another mechanically operable non-inflatable constriction device for use in accordance with the invention.

**[00176]** FIGURE 55B shows the constriction device of FIGURE 55A in a constricted state.

**[00177]** FIGURE 55C is an end view of the embodiment of FIGURE 55B.

**[00178]** FIGURE 56 is a schematic block diagram illustrating an arrangement for supplying an accurate amount of wireless energy used for the operation of the constriction/stimulation unit as described above.

**[00179]** FIGURE 57 schematically shows an embodiment of the system, in which the apparatus is operated with wire bound energy.

**[00180]** FIGURE 58 is a more detailed block diagram of an arrangement for controlling the transmission of wireless energy used for the operation of the constriction/stimulation unit as described above.

**[00181]** FIGURE 59 is a circuit for the arrangement shown in Fig. 19, according to a possible implementation example.

## DETAILED DESCRIPTION OF THE INVENTION

**[00182]** Referring to the drawing figures, like reference numerals designate identical or corresponding elements throughout the several figures.

**[00183]** FIGURES 1A, 1B and 1C schematically illustrate different states of operation of a generally designed apparatus according to the present invention, when the apparatus is applied on a wall portion of the urethra, ureter, renal pelvis or bladder designated BO. The apparatus includes a constriction device and a stimulation device, which are designated CSD, and a control device designated CD for controlling the constriction and stimulation devices CSD. FIGURE 1A shows the apparatus in an inactivation state, in which the constriction device does not constrict the urethra, ureter, renal pelvis or bladder BO and the stimulation device does not stimulate the urethra, ureter, renal pelvis or bladder BO. FIGURE 1B shows the apparatus in a constriction state, in which the control device CD controls the constriction device to gently constrict the wall portion of the urethra, ureter, renal pelvis or bladder BO to a constricted state, in which the blood circulation in the

constricted wall portion is substantially unrestricted and the flow of urine in the urinary passageway of the wall portion is restricted. FIGURE 1C shows the apparatus in a stimulation state, in which the control device CD controls the stimulation device to stimulate different areas of the constricted wall portion, so that almost the entire wall portion of the urethra, ureter, renal pelvis or bladder BO contracts (thickens) and closes the urinary passageway.

**[00184]** FIGURES 1D and 1E show how the stimulation of the constricted wall portion can be cyclically varied between a first stimulation mode, in which the left area of the wall portion (see FIGURE 1D) is stimulated, while the right area of the wall portion is not stimulated, and a second stimulation mode, in which the right area of the wall portion (see FIGURE 1E) is stimulated, while the left area of the wall portion is not stimulated, in order to maintain over time satisfactory blood circulation in the constricted wall portion.

**[00185]** It should be noted that the stimulation modes shown in FIGURES 1D and 1E only constitute a principle example of how the constricted wall portion of the urethra, ureter, renal pelvis or bladder BO may be stimulated. Thus, more than two different areas of the constricted wall portion may be simultaneously stimulated in cycles or successively stimulated. Also, groups of different areas of the constricted wall portion may be successively stimulated.

**[00186]** FIGURES 1F, 1G and 1H illustrate different states of operation of a modification of the general embodiment shown in FIGURES 1A-1E, wherein the constriction and stimulation devices CSD include several separate constriction/stimulation elements, here three elements CSDE1, CSDE2 and CSDE3. FIGURE 1F shows how the element CSDE1 in a first state of operation is activated to both constrict and stimulate the urethra, ureter, renal pelvis or bladder BO, so that the lumen of the urethra, ureter, renal pelvis or bladder BO is closed, whereas the other two elements CSDE2 and CSDE3 are inactivated. FIGURE 1G shows how the element CSDE2 in a second following state of operation is activated, so that the urinary passageway of the urethra, ureter, renal pelvis or bladder BO is closed, whereas the other two elements CSDE1 and CSDE3 are inactivated. FIGURE 1H shows how the element CSDE3 in a following third state of operation is activated, so that the urinary passageway of the urethra, ureter, renal pelvis or bladder BO is closed, whereas the other two elements CSDE1 and CSDE2 are inactivated. By shifting between the first, second and third states of operation, either randomly or in

accordance with a predetermined sequence, different portions of the urethra, ureter, renal pelvis or bladder can by temporarily constricted and stimulated while maintaining the urinary passageway of the urethra, ureter, renal pelvis or bladder closed, whereby the risk of injuring the urethra, ureter, renal pelvis or bladder is minimized. It is also possible to activate the elements CSDE1-CSDE3 successively along the urinary passageway of the urethra, ureter, renal pelvis or bladder to move urine in the urinary passageway.

**[00187]** FIGURES 1I, 1K and 1L illustrate an alternative mode of operation of the modification of the general embodiment. Thus, FIGURE 1I shows how the element CSDE1 in a first state of operation is activated to both constrict and stimulate the urethra, ureter, renal pelvis or bladder BO, so that the urinary passageway of the urethra, ureter, renal pelvis or bladder BO is closed, whereas the other two elements CSDE2 and CSDE3 are activated to constrict but not stimulate the urethra, ureter, renal pelvis or bladder BO, so that the urinary passageway of the urethra, ureter, renal pelvis or bladder BO is not completely closed where the elements CSDE2 and CSDE3 engage the urethra, ureter, renal pelvis or bladder BO. FIGURE 1K shows how the element CSDE2 in a second following state of operation is activated to both constrict and stimulate the urethra, ureter, renal pelvis or bladder BO, so that the urinary passageway of the urethra, ureter, renal pelvis or bladder BO is closed, whereas the other two elements CSDE1 and CSDE3 are activated to constrict but not stimulate the urethra, ureter, renal pelvis or bladder BO, so that the urinary passageway of the urethra, ureter, renal pelvis or bladder BO is not completely closed where the elements CSDE1 and CSDE3 engage the urethra, ureter, renal pelvis or bladder BO. FIGURE 1L shows how the element CSDE3 in a following third state of operation is activated to both constrict and stimulate the urethra, ureter, renal pelvis or bladder BO, so that the urinary passageway of the urethra, ureter, renal pelvis or bladder BO is closed, whereas the other two elements CSDE1 and CSDE2 are activated to constrict but not stimulate the urethra, ureter, renal pelvis or bladder BO, so that the urinary passageway of the urethra, ureter, renal pelvis or bladder BO is not completely closed where the elements CSDE1 and CSDE2 engage the urethra, ureter, renal pelvis or bladder BO. By shifting between the first, second and third states of operation, either randomly or in accordance with a predetermined sequence, different portions of the urethra, ureter, renal pelvis or bladder can by temporarily stimulated while maintaining the urinary passageway of

the urethra, ureter, renal pelvis or bladder closed, whereby the risk of injuring the urethra, ureter, renal pelvis or bladder is reduced. It is also possible to activate the stimulation of the elements CSDE1-CSDE3 successively along the urinary passageway of the urethra, ureter, renal pelvis or bladder BO to move urine in the urinary passageway.

**[00188]** FIGURES 2-4 show basic components of an embodiment of the apparatus according to the invention for controlling the flow of urine in the urinary passageway formed by the tissue wall of a patient's urethra, ureter, renal pelvis or bladder. The apparatus comprises a tubular housing 1 with open ends, a constriction device 2 arranged in the housing 1, a stimulation device 3 integrated in the constriction device 2, and a control device 4 (indicated in FIGURE 4) for controlling the constriction and stimulation devices 2 and 3. The constriction device 2 has two elongate clamping elements 5, 6, which are radially movable in the tubular housing 1 towards and away from each other between retracted positions, see FIGURE 3, and clamping positions, see FIGURE 4. The stimulation device 3 includes a multiplicity of electrical elements 7 positioned on the clamping elements 5, 6, so that the electrical elements 7 on one of the clamping elements 5, 6 face the electrical elements 7 on the other clamping element. Thus, in this embodiment the constriction and stimulation devices form a constriction/stimulation unit, in which the constriction and stimulation devices are integrated in a single piece.

**[00189]** The constriction and stimulation devices may also be separate from each other. In this case, a structure may be provided for holding the electrical elements 7 in a fixed orientation relative to one another. Alternatively, the electrical elements 7 may include electrodes that are separately attached to the wall portion of the patient's urethra, ureter, renal pelvis or bladder.

**[00190]** FIGURES 5A - 5C illustrate in principle the function of the apparatus of FIGURE 2 when the apparatus is applied on a portion 8 of a tissue wall of a patient's urethra, ureter, renal pelvis or bladder. Thus, FIGURE 5A shows the apparatus in a non-clamping state, in which the clamping elements 5, 6 are in their retracted positions and the wall portion 8 extends through the open ends of the housing 1 without being constricted by the clamping elements 5, 6. FIGURE 5B shows the apparatus in a clamping state, in which the clamping elements 5, 6 have been moved from their retracted positions to their clamping positions, in which the clamping elements 5, 6 gently constrict the wall portion 8 to a constricted state, in

which the blood circulation in the constricted wall portion 8 is substantially unrestricted and the flow of urine of the wall portion 8 is restricted. FIGURE 5C shows the apparatus in a stimulation state, in which the clamping elements 5, 6 constrict the wall portion 8 and the electrical elements 7 of the stimulation device 3 electrically stimulate different areas of the wall portion 8, so that the wall portion 8 contracts (thickens) and closes the urinary passageway.

**[00191]** When the apparatus is in its stimulation state, it is important to stimulate the different areas of the wall portion 8 in a manner so that they essentially maintains their natural physical properties over time to prevent the areas from being injured. Consequently, the control device 4 controls the stimulation device 3 to intermittently stimulate each area of the wall portion 8 during successive time periods, wherein each time period is short enough to maintain over time satisfactory blood circulation in the area. Furthermore, the control device 4 controls the stimulation of the areas of the wall portion 8, so that each area that currently is not stimulated restores substantially normal blood circulation before it is stimulated again. To maintain over time the effect of stimulation, *i.e.*, to keep the urinary passageway closed by maintaining the wall portion 8 contracted, the control device 4 controls the stimulation device 3 to stimulate one or more of the areas at a time and to shift the stimulation from one area to another over time. The control device 4 may control the stimulation device 3 to cyclically propagate the stimulation of the areas along the wall portion 8, for example, in accordance with a determined stimulation pattern. To achieve the desired reaction of the tissue wall during the stimulation thereof, the control device may control the stimulation device to, preferably cyclically, vary the intensity of the stimulation of the wall portion 8.

**[00192]** In the embodiment of FIGURES 2 - 4, the electrical elements 7 form a series of fourteen groups of electrical elements 7 extending longitudinally along each elongate clamping element 5 and 6, respectively, see FIGURE 2. The electrical elements 7 of each group of electrical elements 7 form a first path of four electrical elements 7 positioned in a row on clamping element 5 and extending transverse thereto, and a second path of four electrical elements 7 positioned in a row on clamping element 6 and extending transverse thereto. Thus, the two paths of electrical elements 7 extend on mutual sides of the patient's urethra, ureter, renal pelvis or bladder. The control device 4 controls the stimulation device 3 to successively energize the groups of electrical elements 7 in the series of groups in a

direction opposite to or, alternatively, in the same direction as that of the flow of urine of the patient's urethra, ureter, renal pelvis or bladder. Of course, the number of electrical elements 7 of each path of electrical elements 7 can be greater or smaller than four, and several parallel rows electrical elements 7 can form each path of electrical elements 7.

**[00193]** FIGURES 6A - 6C show another embodiment of the invention which includes a tubular housing 9 and three elongate clamping elements 10a, 10b, 10c, which are radially movable in the tubular housing 9 towards and away from a central axis thereof between retracted positions, see FIGURE 6A, and clamping positions, see FIGURE 6B. The three clamping elements 10a-10c are symmetrically disposed around the central axis of the housing 9. The stimulation device of this embodiment includes electrical elements 11a, 11 b, 11c that form a series of groups of elements extending longitudinally along the elongate clamping elements 10a-10c, wherein the electrical elements 11a – 11c of each group of electrical elements form a path of three electrical elements 11a, 11b and 11c extending circumferentially around the central axis of the housing 9. The three electrical elements 11a – 11c of each group are positioned on the three clamping elements 10a-10c, respectively. Thus, the path of three electrical elements 11a-11c extends around the patient's urethra, ureter, renal pelvis or bladder. Of course, the number of electrical elements 11a-11c of each path of electrical elements can be greater than three, and several parallel rows electrical elements 11a-11c can form each path of electrical elements.

**[00194]** FIGURES 7A and 7B show different steps of an electric stimulation mode performed by the apparatus of FIGURE 2 while the clamping elements 5, 6 of the apparatus are constricting a portion of a tissue wall of a patient's urethra, ureter, renal pelvis or bladder 12 to restrict the flow of urine 13 of the urethra, ureter, renal pelvis or bladder 12. For the sake of clarity only the clamping elements 5, 6 of the constriction device 2 are shown in FIGURES 7A, 7B. Thus, FIGURE 7A illustrates how energized electrical elements 7 of groups of electrical elements electrically stimulate a first portion 14 and a second portion 15 of the wall to contract and close the lumen 13. FIGURE 7B illustrates how energized electrical elements 7 of other groups of electrical elements electrically stimulate a third portion 16 of the tubular wall different from the first and second portions to contract and close the lumen 13, while the electrical stimulation of the first and second portions 14, 15 has been ceased, so that substantially normal blood circulation in the first and second portions

is restored. In this manner, the electric stimulation of the constricted urethra, ureter, renal pelvis or bladder is shifted over time from one portion of the urethra, ureter, renal pelvis or bladder to another to insure recurrent restoration of blood circulation in the constricted urethra, ureter, renal pelvis or bladder.

**[00195]** The control device 4 controls the stimulation device 3 to energize the electrical elements 7 with electric biphasic pulses, *i.e.*, combined positive and negative pulses. The desired stimulation effect is achieved by varying different pulse parameters. Thus, the control device 4 controls the stimulation device 3 to vary the pulse amplitude (voltage), the off time period between successive pulses, the pulse duration and the pulse repetition frequency. The pulse current should be between 1 to 30mA. For neural stimulation, a pulse current of about 5mA and a pulse duration of about 300 $\mu$ s are suitable, whereas a pulse current of about 20mA and a pulse duration of about 30 $\mu$ s are suitable for muscular stimulation. The pulse repetition frequency suitably is about 10Hz. For example, as illustrated in the Pulse/time diagram P/t of FIGURE 8A, a pulse combination including a negative pulse PS of short duration and high amplitude (voltage), and a positive pulse PL of long duration and low amplitude following the negative pulse may be cyclically repeated to form a pulse train of such pulse combinations. The energy content of the negative pulse PS should be substantially equal to the energy content of the positive pulse PL.

**[00196]** FIGURE 8B is a pulse/time diagram showing a modification of the electric stimulation shown in FIGURE 8A. Thus, the pulse combination of FIGURE 8A is mixed with a pulse train combination having a first relatively long pulse train PTL of high frequency/low amplitude pulses, appearing simultaneously with the positive pulse PL of the pulse combination of FIGURE 8A, and a second relatively short pulse train PTS of high frequency/low amplitude appearing simultaneously with the negative pulse PS of the pulse combination shown in FIGURE 8A. As a result, the high frequency/low amplitudes pulse trains PTL and PTS are superimposed on the positive and negative pulses PL and PS of FIGURE 8A, as illustrated in FIGURE 8B. The pulse configuration of FIGURE 8B, and variations thereof, is beneficial to use in connection with the stimulation of the urethra, ureter, renal pelvis or bladder, in order to achieve the desired stimulation effect.

**[00197]** Preferably, the electric pulses form pulse trains, as illustrated in the Pulse/time diagrams P/t of FIGURES 9A, 9B, 9C and 9D. The Pulse/time diagram

P/t of FIGURE 9A represents an individual area of the wall portion of the patient's urethra, ureter, renal pelvis or bladder which is stimulated with a pulse train 18A. The pulse train 18A includes three initial negative pulses, each of which is of short duration and high amplitude (voltage), and one positive pulse of long duration and low amplitude following the negative pulses. After a delay to enable the area of the urethra, ureter, renal pelvis or bladder to restore substantially normal blood circulation, the pulse train 18A is repeated.

**[00198]** The Pulse/time diagram P/t of FIGURE 9B represents another individual area of the wall portion, which is stimulated with a pulse train 18B having the same configuration as the pulse train 18A. The pulse trains 18A and 18B are shifted relative to each other, so that they partially overlap one another to ensure that the constricted wall portion always is stimulated to contract as desired.

**[00199]** The pulse/time diagrams P/t of FIGURES 10A and 10B represent two different areas of the wall portion, which are stimulated with cyclically repeated pulse trains 18C and 18D, respectively, having the same configuration. Each pulse train 18C, 18D includes two initial negative pulses, each of which is of short duration and high amplitude (voltage), and one positive pulse of long duration and low amplitude following the two negative pulses. In this case, the pulse trains 18C and 18D are shifted relative to each other, so that they do not overlap each other. Thus, the off time period between adjacent pulse trains 18C is longer than the duration of pulse train 18D and the off time period between adjacent pulse trains 18D is longer than the duration of pulse train 18C.

**[00200]** The pulse trains 18A, 18B, 18C and 18D can be configured in many different ways. Thus, the control device 4 can control the stimulation device 2 to vary the length of each pulse train, the repetition frequency of the pulse trains, the number of pulses of each pulse train, and/or the off time periods between the pulse trains. Typically, the control device 4 controls each off time period between the pulse trains to last long enough to restore substantially normal blood circulation in the area that just has been stimulated before that area again is stimulated with electric pulses.

**[00201]** FIGURES 11A and 11B show another embodiment of the invention that controls flow of urine in the urethra, ureter, renal pelvis or bladder 19, comprising a constriction device with two clamping elements 20a and 20b, a stimulation device in the form of two thermal stimulation elements 21a and 21b integrated in the clamping elements 20a, 20b, respectively, and a control device 4 for controlling the clamping



elements 20a, 20b and stimulation elements 21a, 21b. The clamping elements 20a and 20b are movable towards and away from each other in the same manner as described above in connection with the embodiment according to FIGURES 5A-5C. The thermal stimulation elements 21a and 21b, which may include Peltier elements, are positioned on the clamping elements 20a, 20b, so that the thermal elements 21a are facing the thermal elements 21b. FIGURE 11A shows how the clamping elements 20a, 20b constrict the urethra, ureter, renal pelvis or bladder 19, so that the flow of urine is restricted. FIGURE 11B shows how the control device 4 controls the thermal stimulation elements 21a, 21b to cool the wall of the urethra, ureter, renal pelvis or bladder 19, so that the wall contracts and closes the urethra, ureter, renal pelvis or bladder 19. To release the urethra, ureter, renal pelvis or bladder 19, the control device 4 controls the thermal stimulation elements 21a, 21b to heat the wall of the urethra, ureter, renal pelvis or bladder 19, so that the wall expands.

**[00202]** FIGURES 12A and 12B show hydraulic operation means suited for operating the constriction device of the embodiments described above. Specifically, FIGURES 12A and 12B show the apparatus of FIGURE 2 provided with such means for hydraulic operation of the constriction device 2. (The stimulation device is not shown.) Thus, the housing 1 forms two hydraulic chambers 22a and 22b, in which the two clamping elements 5, 6 are slidable back and forth relative to the tissue wall portion 8 of a patient's urethra, ureter, renal pelvis or bladder. The hydraulic operation means include an expandable reservoir 23, such as an elastic balloon, containing hydraulic fluid, conduits 24a and 24b between the reservoir 23 and the hydraulic chambers 22a, 22b, and a two-way pump 25 for pumping the hydraulic fluid in the conduits 24a, 24b. The control device 4 controls the pump 25 to pump hydraulic fluid from the reservoir 23 to the chambers 22a, 22b to move the clamping elements 5, 6 against the wall portion 8, whereby the wall portion 8 is constricted, see FIGURE 12B, and to pump hydraulic fluid from the chambers 22a, 22b to the reservoir 23 to move the clamping elements 5, 6 away from the wall portion 8, whereby the wall portion 8 is released, see FIGURE 12A.

**[00203]** Alternatively, the embodiment of FIGURES 12A and 12B may be manually operated by applying suitable manually operable hydraulic means for distributing the hydraulic fluid between the expandable reservoir 23 and the hydraulic chambers 22a, 22b. In this case the pump 25 is omitted.

**[00204]** FIGURES 13A and 13B schematically show a mechanically operable embodiment of the invention, comprising an open ended tubular housing 26 applied on the tissue wall portion 8 of a patient's urethra, ureter, renal pelvis or bladder, a constriction device 27 arranged in the housing 26 and a control device 4 for controlling the constriction device 27. A stimulation device (not shown) as described above is also provided in the housing 26. The constriction device 27 includes a clamping element 28, which is radially movable in the tubular housing 26 towards and away from the wall portion 8 between a retracted position, see FIGURE 13A, and a clamping position, see FIGURE 13B, in which the clamping element 28 gently constricts the wall portion 8. Mechanical operation means for mechanically operating the clamping element 28 includes an electric motor 29 attached to the housing 26 and a telescopic device 30, which is driven by the motor 29 and operatively connected to the clamping element 28. The control device 4 controls the electric motor 29 to expand the telescopic device 30 to move the clamping element 28 against the wall portion 8, whereby the wall portion 8 is constricted, see FIGURE 13B, and controls the motor 29 to retract the telescopic device 30 to move the clamping element 28 away from the wall portion 8, whereby the wall portion 8 is released, see FIGURE 13A.

**[00205]** Alternatively, the motor 29 may be omitted and the telescopic device 30 be modified for manual operation, as shown in FIGURE 13C. Thus, a spring 30a may be provided acting to keep the telescopic device 30 expanded to force the clamping element 28 against the wall portion 8. The mechanical operation means may include a subcutaneously implanted lever mechanism 29a that is operatively connected to the telescopic device 30. The patient may push the lever mechanism 29a through the patient's skin 29b to pull the telescopic device 30 against the action of the spring 30a to the retracted position of the telescopic device 30, as indicated in phantom lines. When the patient releases the lever mechanism 29a, the spring 30a expands the telescopic device 30, whereby clamping element 28 is forced against the wall portion 8.

**[00206]** The mechanical operation means as described above in connection with FIGURES 13A, 13B and 13C may also be implemented in the embodiments according to FIGURES 1-11.

**[00207]** FIGURE 14A illustrates the embodiment of FIGURE 2 applied on the urethra 31 of a urinary stress and overflow incontinent patient with the clamping

elements 5, 6 of the constriction device 2 constricting the urethra 31 and the stimulation device 3 energized to close the urinary passageway. (For the sake of clarity, the housing is not shown and the clamping elements 5, 6 are exaggerated.) In this embodiment, a control device includes an external control unit in the form of a hand-held wireless remote control 32, and an implanted internal control unit 33, which may include a microprocessor, for controlling the constriction and stimulation devices. The remote control 32 is operable by the patient to control the internal control unit 33 to switch on and off the constriction device and/or the stimulation device. Alternatively, however, the remote control 32 may be replaced by a subcutaneously implanted push button that is manually switched by the patient between "on" and "off". Such a manually operable push button may also be provided in combination with the remote control 32 as an emergency button to allow the patient to stop the operation of the apparatus in case of emergency or malfunction.

**[00208]** The internal control unit 33 controls an implanted operation device 34 to move the clamping elements 5, 6. An implanted source of energy 35, such as a rechargeable battery, powers the operation device 34. The internal control unit 33, which may be implanted subcutaneously or in the abdomen, also works as an energy receiver, *i.e.*, for transforming wireless energy into electric energy and charging the implanted source of energy 35 (rechargeable battery) with the electric energy.

**[00209]** An implanted sensor 36 senses a physical parameter of the patient, such as the pressure in the bladder, or a parameter that relates to the pressure in the bladder, wherein the internal control unit 33 controls the constriction device 2 and/or the stimulation device 3 in response to signals from the sensor 36. In this embodiment the sensor 36 is a pressure sensor, wherein the internal control unit 33 controls the constriction device and/or stimulation device to change the constriction of the patient's urethra 31 in response to the pressure sensor 36 sensing a predetermined value of measured pressure. For example, the control unit 33 may control the constriction device and/or stimulation device to increase the constriction of the patient's urethra 31 in response to the pressure sensor sensing an increased pressure. Alternatively or in combination, the remote control 32 controls the constriction device and/or stimulation device in response to signals from the sensor 36, in the same manner as the internal control unit 33.

**[00210]** The remote control 32 may be equipped with means for producing an indication, such as a sound signal or displayed information, in response to signals from the sensor 36. When the patient's attention is taken by such an indication indicating an increased pressure exceeding a threshold value, or when the patient desires to urinate, he or she may use the remote control to control the constriction device and stimulation device to pump urine through the urethra.

**[00211]** The embodiment of FIGURE 14B is similar to that of FIGURE 14A, except that the constriction device is applied to an urether 37 instead of the urethra. This embodiment is in other aspects similar or identical to the embodiment described above with reference to FIGURE 14A. It will be appreciated that more than one constriction device can be used, e.g., one constriction device on each of the two ureters.

**[00212]** FIGURE 14C illustrates a constriction device 68 similar to the embodiment of FIGURE 27 applied on the urinary bladder of a patient suffering from urinary dysfunction, i.e., disability to empty the bladder. The clamping elements 69 of the constriction device 68 are positioned on different sides of the bladder. In this embodiment, the control device includes an external control unit in the form of a hand-held wireless remote control 32A and an implanted internal control unit 33, which may include a microprocessor 33A, for controlling the constriction and stimulation devices. There is an external energy transmitter 32A that transmits wireless energy. The remote control 32A and the energy transmitter 32B may be separate devices, as shown in FIGURE 14C, or may be integrated in a single hand-held device. The remote control 32A is operable by the patient to control the internal control unit 33 to switch on and off the constriction device and/or the stimulation device. The internal control unit 33 also includes a push button 33B that can be used by the patient to manually switch "on" and "off" the operation of the constriction and/or stimulation devices. The button also serves as an emergency button to allow the patient to stop the operation of the apparatus in case of emergency or malfunction.

**[00213]** The internal control unit 33 controls a hydraulic operation device 34 to move the clamping elements 69. An injection port 33F integrated in the push button 33B is provided to calibrate the amount of hydraulic fluid in hydraulic components of the hydraulic operation device. The internal control unit 33 also includes a source of energy 33C, such as a rechargeable battery, for powering the operation device 34,

and an energy receiver 33D for transforming wireless energy transmitted by the external energy transmitter 32B into electric energy and charging the implanted source of energy 33C (rechargeable battery) with the electric energy.

**[00214]** An implanted sensor 36 applied on the constriction device (here on the clamping element 69) senses a physical parameter of the patient, such as the pressure in the bladder, or a parameter that relates to the pressure in the bladder. the internal control unit 33 includes a signal transmitter 33E that sends an alarm signal to the external remote control 32A in response to signals from the sensor 36 indicating a predetermined value of measured pressure.

**[00215]** The remote control 32 may be equipped with means for producing an indication, such as a sound signal or displayed information, in response to received signals such as alarm signals. When the patient's attention is taken by such an indication indicating an increased pressure exceeding a threshold value, or when the patient desires to urinate, he or she may conveniently use the remote control 32A or the push button 33B to activate the operation device 34 to empty the bladder.

**[00216]** The embodiment of FIGURE 14D is similar to that of FIGURE 14C, except that the clamping elements 5, 6 of the constriction device 2 shown in FIGURE 14A is applied on the urethra 31. The embodiment of FIGURE 14D is suited to treat patients who are incontinent as well as disabled to empty the bladder.

**[00217]** The skilled person understands that the embodiments of FIGURES 14A-14D could be combined in many different ways as desired. For example, as shown in FIGURE 14B, another constriction device may be applied on the patient's urethra 37 in the embodiment of FIGURE 14C.

**[00218]** FIGURES 15-17 show a mechanically operable constriction device having an elongated constriction member in the form of a circular resilient core 37 with two overlapping end portions 38, 39. The core 37 defines a substantially circular restriction opening and is enclosed in an elastic soft hose 40 except at a releasable and lockable joint 41 of the core 37, which when released enables application of the core 37 with its hose 40 around a portion of the tissue wall of a patient's urethra, ureter, renal pelvis or bladder. The materials of all of these elements are bio-compatible so that the patient's body will not reject them. An operation device 42 for mechanically operating the longitudinal extension of the core 37 to change the size of the restriction opening comprises a drive wheel 43 in frictional engagement with the overlapping end portions 38, 39 of the core 37. The drive wheel 43 is journalled

on a holder 44 placed in the hose 40 and provided with two counter pressure rollers 45, 46 pressing the respective end portions 38, 39 of the core 37 against the drive wheel 43 to increase the frictional engagement there between. An electric motor 47 of the operation device is connected to the drive wheel 43 via a long flexible drive shaft 48, and is moulded together with a remote controlled power supply unit 49 in a body 50 of silicone rubber. The length of the flexible drive shaft 48 is selected so that the body 50 can be placed in a desired position in the patient's body, suitably in the abdomen.

**[00219]** The power supply unit 49 can be controlled to power the electric motor 47 to turn the drive wheel 43 in one direction to reduce the diameter of the core 37, so that the wall portion is constricted, or to turn the drive wheel 43 in the opposite direction to increase the diameter of the core 37, so that the wall portion is released.

**[00220]** In accordance with a first alternative, a rack gear may be formed on one of the end portions 38, 39 of the core 37 and the drive wheel 43 may be replaced by a drive gear wheel connected to the other end portion of the core 37 and in mesh with the rack gear.

**[00221]** In accordance with a second alternative, the operation device 42 may be designed as a worm-driven hose clamp, *i. e.*, one of the end portions 38, 39 of the core 37 may be provided with threads and the other end portion of the core 37 may be provided with a worm, the threads of which interacts with the threads of said one end portion of the core 37. The threads of such a worm may also interact with threads provided on both end portions 38, 39 of the core 37. In this alternative, the electric motor 47 turns the worm in one direction to reduce the diameter of the core 37, so that the wall portion is constricted, or turn the worm in the opposite direction to increase the diameter of the core 37, so that the wall portion is released in one direction to reduce the diameter of the core 37, so that the wall portion is constricted, or turns the clamping screw in the opposite direction to increase the diameter of the core 37, so that the wall portion is released.

**[00222]** FIGURE 18 shows a constriction device which is identical to the embodiment of FIGURES 15-17, except that the motor 47 is encapsulated in the hose 40 so that it is fixed to the core 37 and has a short drive shaft 51, and that the motor 47 is positioned relative to the core 37, such that the drive shaft 51 extends substantially tangentially to the circular core 37. There is an angular gearing 52 connecting the drive shaft 51 to the drive wheel 43.

**[00223]** FIGURE 19 shows a suitable alternative arrangement for the motor 47 in the embodiment of FIGURE 18, comprising a first clamping member 53 secured to one end portion of the core 37 and a second clamping member 54 secured to the other end portion 39 of the core 37. The motor 47 is secured to the first clamping member 53 and is operatively connected to a worm gear 55 via a gear transmission 56. The worm gear 55 is journaled at its opposite ends on holders 57 and 58, which are rigidly secured to the clamping member 53 and the motor 47, respectively. The second clamping member 54 has a pinion in mesh with the worm gear 55. When the motor 47 is powered, the worm gear 55 rotates, and will thereby pull the end portion 39 of the core 37 in one or the opposite longitudinal direction, so that the diameter of the substantially circular core 37 is either increased or decreased. The motor 47, worm gear 55, gear transmission 56 and second clamping member 54 constitute a servo system of the type that transfers a weak force acting on a moving element having a long stroke into a strong force acting on another moving element having a short stroke.

**[00224]** FIGURE 20 shows a constriction device including a plurality of arcuate lamellae 59 arranged like the conventional adjustable aperture mechanism of a camera. A motor 60 operates the lamellae 59 to change the size of a restriction opening defined by the lamellae 59.

**[00225]** FIGURES 21-23 show a constriction device including two semi-circular elements 61 and 62, which are hinged together such that the semi-circular elements 61, 62 are swingable relative to each other between a fully open state in which they substantially form a circle, as illustrated in FIGURE 22, and an angular state, in which the size of the restriction opening defined by the semi-circular elements 61, 62 is reduced, as illustrated in FIGURE 23. A motor 63 operates the semi-circular elements 61, 62 to swing them relative to each other.

**[00226]** FIGURES 24-26 show a constriction device including an elastic belt 64 forming a circle and having a substantially oval cross-section. A motor 67 operates the belt 64 to turn around the longitudinal extension thereof between a fully open state, in which the inner broader side of the belt 64 forms a substantially cylindrical surface, as illustrated in FIGURE 25, and a reduced open state, in which the inner broader side of the belt 64 forms a substantially conical surface, as illustrated in FIGURE 26.

**[00227]** FIGURE 27 shows a constriction device 68 having two rigid articulated clamping elements 69 positioned on opposite sides of a portion of a tubular tissue wall 70 of a patient's urethra, ureter, renal pelvis or bladder. An operation device 71 turns the clamping elements 69 toward each other to clamp the wall portion 70 between the clamping elements 69 to thereby contract the wall portion, and turns the clamping elements 69 away from each other to release the wall portion from the clamping elements 69.

**[00228]** FIGURES 28 and 29 show an embodiment of the apparatus of the invention comprising a constriction device 300 having three bending members 301, 302 and 303 displaced relative to one another in a row along a portion of the tissue wall 304 of a patient's urethra, ureter, renal pelvis or bladder and positioned alternately on opposite sides of the wall portion 304. (Alternatively, each member 301, 302 and 303 may take the shape of an hour-glass.) An operation device (not shown) moves the two outer members 301, 303 laterally against the wall portion 304 in one direction and the intermediate member 302 against the wall portion 304 in the opposite direction to bend the wall portion 304, to thereby constrict the wall portion 304, as illustrated in FIGURE 29. To release the wall portion 304 the operation device moves the members 301-303 away from the wall portion 304 to the position shown in FIGURE 28.

**[00229]** FIGURES 30A and 30B show a hydraulically operable elongated constriction device in the form of a band 72 having an expandable/contractible cavity 73, which is in fluid communication with an adjustable reservoir 74 containing hydraulic fluid. FIGURE 30A illustrates when the band is in a non-constriction state, whereas FIGURE 30B illustrates when the band is in a constriction state, in which the cavity 73 is expanded by hydraulic fluid supplied by the reservoir 74.

**[00230]** FIGURES 31A, 31B, 31C and 31D are block diagrams of four differently operated hydraulic constriction devices. FIGURE 31A shows the band 72 of FIGURE 30A, the cavity 73 of which is in fluid communication with a reservoir 75. FIGURE 31B shows the embodiment of FIGURE 30A, in which the cavity 73 of the band 72 is in fluid communication with the reservoir 74 via an operation device in the form of a two-way pump 76. FIGURE 31C shows an operation device in the form of a reverse servo system with a first closed system controlling a second system. The reverse servo system comprises an adjustable fluid supply reservoir 77 and an adjustable servo reservoir 78. The servo reservoir 78 controls a larger adjustable



reservoir 79 which in connection with the band 72 applied around a portion of the tissue wall of a patient's urethra, ureter, renal pelvis or bladder varies the volume of the cavity 73 of the band 72, which in turn varies the constriction of the wall portion. FIGURE 31D shows an embodiment identical to the embodiment of FIGURE 31C, except that the larger reservoir 79 is omitted. Instead, the servo reservoir 78 is in fluid communication with the cavity of the band 72.

**[00231]** In all of the above embodiments according to FIGURES 12A through 30B, stimulation devices may be provided to form constriction/stimulation units, in which the stimulation devices include a multiplicity of electrical elements 7 (indicated in FIGURES 12A – 15, 18, 20 – 23, 26 – 31B) positioned on the constriction devices.

**[00232]** FIGURE 32 is a cross-sectional view of a fluid supply device including a bellows reservoir 80 defining a chamber 81, the size of which is variable by an operation device comprising a remote controlled electric motor 82. The reservoir 80 and the motor 82 are placed in a housing 83. Moving a large wall 84 varies the chamber 81. The wall 84 is secured to a nut 85, which is threaded on a rotatable spindle 86. The spindle 86 is rotated by the motor 82. A battery 89 placed in the housing 83 powers the motor 82. A signal receiver 90 for controlling the motor 82 is also placed in the housing 83. Alternatively, the battery 89 and the signal receiver 90 may be mounted in a separate place. The motor 82 may also be powered with energy transferred from transmitted signals.

**[00233]** Where applicable, the fluid supply device of FIGURE 32 may be used for supplying hydraulic fluid for the operation of the constriction devices described in this specification. For example, the fluid supply device of FIGURE 32 may be substituted for the reservoir 74 in the embodiment according to FIGURE 30A.

**[00234]** FIGURES 33A and 33B show a reverse servo including a rectangular housing 91 and an intermediate wall 92, which is movable in the housing 91. A relatively large, substantially cylindrical bellows reservoir 93 is arranged in the housing 91 and is joined to the movable intermediate wall 92. Another cylindrical bellows reservoir 94, which is substantially smaller than reservoir 93, is arranged in the housing 91 at the other side of the intermediate wall 92 and is also joined to the wall 92. The small bellows reservoir 94 has a fluid supply pipe 95 and the large bellows reservoir 93 has a fluid supply pipe 96.

**[00235]** Referring to FIGURE 33A, when a small amount of hydraulic fluid is conducted through the supply pipe 95 into the small bellows reservoir 94, the small

bellows reservoir 94 expands and pushes the movable intermediate wall 92 towards the large bellows reservoir 93. As a result, the large bellows reservoir 93 is contracted by the intermediate wall 92, whereby a large amount of hydraulic fluid is forced out of the large bellows reservoir 93 through the supply pipe 96, as shown in FIGURE 33B.

**[00236]** For example, the reverse servo of FIGURES 33A and 33B may be used in the embodiment of FIGURE 31C, wherein the small bellows reservoir 94 corresponds to the small servo reservoir 78 and the large bellows reservoir 93 corresponds to the large reservoir 79. Also, the reverse servo of FIGURES 33A and 33B may be used in the embodiment of FIGURE 30A and 30B, wherein the small bellows reservoir 94 is connected to the adjustable reservoir 74, and the large bellows reservoir 93 is connected to the cavity 73 of the band 72.

**[00237]** FIGURE 34 schematically shows a hydraulically operable constriction device 97 of the apparatus of the invention, which is similar to the embodiment shown in FIGURE 30A, except that the hydraulic system is designed differently. Thus, the constriction device 97 includes a relatively small inflatable cavity 98, which is in fluid communication with a reservoir 99 containing hydraulic fluid, and a relatively large cavity 100, which is displaceable by small cavity 98. Small cavity 98 is adapted to displace large cavity 100 to constrict the patient's wall portion when small cavity 98 is inflated and to displace large cavity 100 to release the wall portion when small cavity 98 is deflated. Thus, a relatively small addition of hydraulic fluid from reservoir 99 to small cavity 98 causes a relatively large increase in the constriction of the wall portion.

**[00238]** Large cavity 100 is defined by a contraction element in the form of a big balloon 101, which may be connected to an injection port (not shown) for calibration of the volume of large cavity 100. Adding fluid to or withdrawing fluid from the injection port with the aid of a syringe calibrates the volume of balloon 101. Small cavity 98 is defined by a small bellows 102 attached to an annular frame 103 of constriction device 97 and at the opposite end is attached to balloon 101.

**[00239]** FIGURES 35A and 35B schematically illustrate the operation of constriction device 97, when annular frame 103 is applied around the wall portion of the patient's urethra, ureter, renal pelvis or bladder. Referring to FIGURE 35A, when small cavity 98 is deflated bellows 102 pulls balloon 101 inwardly into annular frame 103, so that constriction device 97 constricts the wall portion. Referring to FIGURE

35B, when small cavity 98 is inflated bellows 102 pulls balloon 101 out of annular frame 103, so that constriction device 97 releases the wall portion.

**[00240]** As mentioned above, the constriction device and stimulation device can co-operate to actively move the urine in the urinary passageway of a patient's urethra, ureter, renal pelvis or bladder. This can be achieved using the constriction/stimulation unit shown in FIGURE 2. Thus, in accordance with a first cooperation option, the clamping elements 5, 6 of the constriction device constricts the wall portion 8 without completely closing the urinary passageway, whereby the flow of urine is restricted, and the control device 4 controls the electrical elements 7 to progressively stimulate the constricted wall portion in the downstream or upstream direction of the urinary passageway to cause progressive contraction of the wall portion 8 to move the urine in the urinary passageway.

**[00241]** In accordance with a second cooperation option, the constriction device constricts the wall portion so that the flow of urine is restricted, and the control device 4 controls a few electrical elements 7 at one end of the elongate clamping elements 5, 6 to stimulate the constricted wall portion 8 to close the urinary passageway either at an upstream end or a downstream end of the wall portion 8. With the urinary passageway closed in this manner, the control device 4 controls the constriction device to increase the constriction of the wall portion, whereby the urine in the urinary passageway is moved downstream or upstream of the wall portion 8.

**[00242]** In another embodiment of the invention for performing the second cooperation option, the constriction device constricts the wall portion so that the flow of urine is restricted, and the control device 4 controls the stimulation device to stimulate the constricted wall portion while the constriction device varies the constriction of the different areas of the wall portion, such that the wall portion is progressively constricted in the downstream or upstream direction of the urinary passageway. FIGURES 36A – 36E show different operation stages of such an alternative embodiment, which comprises a constriction device 104 including two elongate constriction elements 105, 106 having convex surfaces 107, 108 that abut a length of the wall portion 8 on mutual sides of the urethra, ureter, renal pelvis or bladder, and a multiplicity of electrical elements 7 (such as electrodes) that are positioned on the convex surfaces 107, 108. The control device 4 controls the electrical elements 7 during operation of the constriction device 104 and controls the elongate constriction elements 105, 106 to move relative to the wall portion 8 so that

the constriction elements 105, 106 progressively constrict the wall portion 8, as appears from FIGURES 36A to 36D.

**[00243]** Thus, in an initial position of the constriction elements 105, 106 shown in FIGURE 36A, the wall portion is not constricted by the constriction elements 105, 106 and the electrical elements 7 are not energized. Starting from this initial position, the control device 4 controls the constriction elements 105, 106 to swing the left ends of the constriction elements 105, 106 toward the wall portion (indicated by arrows) to constrict the wall portion 8, see FIGURE 36B, while energizing the electrical elements 7, so that the electrical elements 7 that contact the wall portion 8 contract the latter. FIGURE 36 C shows how the urinary passageway of the wall portion 8 is completely closed by the thickened wall portion 8. Then, as shown in FIGURE 36C, the control device 4 controls the constriction elements 105, 106 to move so that their right ends are moving towards each other (indicated by arrows), while the convex surfaces 107, 108 of the constriction elements 105, 106 are rolling on each other with the contracted wall portion 8 between them, see FIGURE 36D. As a result, the urine in the urinary passageway of the urethra, ureter, renal pelvis or bladder is forced to the right (indicated by a white arrow). When the constriction elements 105, 106 have rolled on each other to the position shown in FIGURE 36E, the control device 4 controls the right ends of the constriction elements 105, 106 to move away from each other (indicated by arrows in FIGURE 36E) to the initial position shown in FIGURE 36A. The operation stages described according to FIGURES 36A to 36E can be cyclically repeated a number of times until the desired amount of urine has been moved in the urinary passageway of the urethra, ureter, renal pelvis or bladder in a peristaltic manner.

**[00244]** Alternatively, only one of the constriction elements 105, 106 can be provided with a convex surface, whereas the other constriction element has a plane surface that abuts the wall portion. It is also possible to use a single constriction element with a convex surface that presses the wall portion 8 of the urethra, ureter, renal pelvis or bladder against a bone of the patient.

**[00245]** In the embodiment according to FIGURES 36A to 36E, the control device 4 may control the electrical elements 7 to progressively stimulate the constricted wall portion 8 to cause progressive contraction thereof in harmony with the movement of the elongate constriction elements 105, 106, as the convex surfaces 107, 108 of the constriction elements 105, 106 are rolling on each other.

.FIGURE 37 schematically shows a general embodiment of the apparatus of the invention, in which energy is transferred to energy consuming components of the apparatus implanted in the patient. The apparatus of FIGURE 37 comprises an implanted constriction/stimulation unit 110, which is operable to gently constrict a portion of the tissue wall of a patient's urethra and to stimulate different areas of the constricted portion to cause contraction of the wall portion. The constriction device of the constriction/stimulation unit 110 is capable of performing a reversible function, *i.e.*, to constrict and release the wall portion, so that the constriction/stimulation unit 110 works as an artificial urethral sphincter.

A source of energy 111 is adapted to supply energy consuming components of the constriction/stimulation unit 110 with energy via a power supply line 112. A wireless remote control or a subcutaneously implanted switch operable by the patient to switch on or off the supply of energy from the source of energy may be provided. The source of energy may be an implantable permanent or rechargeable battery, or be included in an external energy-transmission device, which may be operable directly by the patient or be controlled by a remote control operable by the patient to transmit wireless energy to the energy consuming components of the constriction/stimulation unit. Alternatively, the source of energy may comprise a combination of an implantable rechargeable battery, an external energy-transmission device and an implantable energy-transforming device for transforming wireless energy transmitted by the external energy-transmission device into electric energy for the charge of the implantable rechargeable battery.

FIGURE 38 shows a special embodiment of the general embodiment of FIGURE 37 having some parts implanted in a patient and other parts located outside the patient's body. Thus, in FIGURE 38 all parts placed to the right of the patient's skin 109 are implanted and all parts placed to the left of the skin 109 are located outside the patient's body. An implanted energy-transforming device 111A of the apparatus is adapted to supply energy consuming components of the constriction/stimulation unit 110 with energy via the power supply line 112. An external energy-transmission device 113 of the apparatus includes a wireless remote control transmitting a wireless signal, which is received by a signal receiver incorporated in the implanted energy-transforming device 111A. The implanted energy-transforming device 111A transforms energy from the signal into electric energy, which is supplied via the power supply line 112 to the constriction/stimulation unit 110.

**[00246]** The apparatus of FIGURE 38 may also include an implanted rechargeable battery for energizing energy consuming implanted components of the apparatus. In this case, the implanted energy-transforming device 111A also charges the battery with electric energy, as the energy-transforming device transforms energy from the signal into the electric energy.

**[00247]** A reversing device in the form of an electric switch 114, such as a microprocessor, is implanted in the patient for reversing the constriction device of the constriction/stimulation unit 110. The wireless remote control of the external energy-transmission device 113 transmits a wireless signal that carries energy and the implanted energy-transforming device 111A transforms the wireless energy into a current for operating the switch 114. When the polarity of the current is shifted by the energy-transforming-device 111A the switch 114 reverses the function performed by the constriction device of the constriction/stimulation unit 110.

**[00248]** FIGURE 39 shows an embodiment of the invention including the energy-transforming device 111A, the constriction/stimulation unit 110 and an implanted operation device in the form of a motor 115 for operating the constriction device of the constriction/stimulation unit 110. The motor 115 is powered with energy from the energy-transforming device 111A, as the remote control of the external energy-transmission device 113 transmits a wireless signal to the receiver of the energy-transforming device 111A.

**[00249]** FIGURE 40 shows an embodiment of the invention including the energy-transforming device 111A, the constriction/stimulation unit 110 and an implanted assembly 116 including a motor/pump unit 117 and a fluid reservoir 118. In this case the constriction device of the constriction/stimulation unit 110 is hydraulically operated, *i.e.*, hydraulic fluid is pumped by the motor/pump unit 117 from the reservoir 118 to the constriction/stimulation unit 110 to constrict the wall portion, and hydraulic fluid is pumped by the motor/pump unit 117 back from the constriction/stimulation unit 110 to the reservoir 118 to release the wall portion. The implanted energy-transforming device 111A transforms wireless energy into a current, for powering the motor/pump unit 117.

**[00250]** FIGURE 41 shows an embodiment of the invention comprising the external energy-transmission device 113 that controls the control unit 122 to reverse the motor 115 when needed, the constriction/stimulation unit 110, the constriction device of which is hydraulically operated, and the implanted energy-transforming

device 111A, and further comprising an implanted hydraulic fluid reservoir 119, an implanted motor/pump unit 120, an implanted reversing device in the form of a hydraulic valve shifting device 121 and a separate external wireless remote control 111B. The motor of the motor/pump unit 120 is an electric motor. In response to a control signal from the wireless remote control of the external energy-transmission device 113, the implanted energy-transforming device 111A powers the motor/pump unit 120 with energy from the energy carried by the control signal, whereby the motor/pump unit 120 distributes hydraulic fluid between the reservoir 119 and the constriction device of the constriction/stimulation unit 110. The remote control 111B controls the shifting device 121 to shift the hydraulic fluid flow direction between one direction in which the fluid is pumped by the motor/pump unit 120 from the reservoir 119 to the constriction device of the constriction/stimulation unit 110 to constrict the wall portion, and another opposite direction in which the fluid is pumped by the motor/pump unit 120 back from the constriction device of the constriction/stimulation unit 110 to the reservoir 119 to release the wall portion.

**[00251]** FIGURE 42 shows an embodiment of the invention including the energy-transforming device 111A and the constriction/stimulation unit 110. A control unit 122, an accumulator 123 and a capacitor 124 are also implanted in the patient. A separate external wireless remote control 111B controls the control unit 122. The control unit 122 controls the energy-transforming device 111A to store electric energy in the accumulator 123, which supplies energy to the constriction/stimulation unit 110. In response to a control signal from the wireless remote control 111B, the control unit 122 either releases electric energy from the accumulator 123 and transfers the released energy via power lines, or directly transfers electric energy from the energy-transforming device 111A via the capacitor 124, which stabilises the electric current, for the operation of the constriction/stimulation unit 110.

**[00252]** In accordance with one alternative, the capacitor 124 in the embodiment of FIGURE 42 may be omitted. In accordance with another alternative, the accumulator 123 in this embodiment may be omitted.

**[00253]** FIGURE 43 shows an embodiment of the invention including the energy-transforming device 111A, the constriction/stimulation unit 110. A battery 125 for supplying energy for the operation of the constriction/stimulation unit 110 and an electric switch 126 for switching the operation of the constriction/stimulation unit 110 are also implanted in the patient. The switch 126 is operated by the energy supplied

by the energy-transforming device 111A to switch from an off mode, in which the battery 125 is not in use, to an on mode, in which the battery 125 supplies energy for the operation of the constriction/stimulation unit 110.

**[00254]** FIGURE 44 shows an embodiment of the invention identical to that of FIGURE 43, except that a control unit 122 also is implanted in the patient. A separate external wireless remote control 111B controls the control unit 122. In this case, the switch 126 is operated by the energy supplied by the energy-transforming device 111A to switch from an off mode, in which the wireless remote control 111B is prevented from controlling the control unit 122 and the battery 125 is not in use, to a standby mode, in which the remote control 111B is permitted to control the control unit 122 to release electric energy from the battery 125 for the operation of the constriction/stimulation unit 110.

**[00255]** FIGURE 45 shows an embodiment of the invention identical to that of FIGURE 44, except that the accumulator 123 is substituted for the battery 125 and the implanted components are interconnected differently. In this case, the accumulator 123 stores energy from the energy-transforming device 111A. In response to a control signal from the wireless remote control 111B, the implanted control unit 122 controls the switch 126 to switch from an off mode, in which the accumulator 123 is not in use, to an on mode, in which the accumulator 123 supplies energy for the operation of the constriction/stimulation unit 110.

**[00256]** FIGURE 46 shows an embodiment of the invention identical to that of FIGURE 45, except that the battery 125 also is implanted in the patient, and the implanted components are interconnected differently. In response to a control signal from the wireless remote control 111B, the implanted control unit 122 controls the accumulator 123, which may be a capacitor, to deliver energy for operating the switch 126 to switch from an off mode, in which the battery 125 is not in use, to an on mode, in which the battery 125 supplies electric energy for the operation of the constriction/stimulation unit 110.

**[00257]** Alternatively, the switch 126 may be operated by energy supplied by the accumulator 123 to switch from an off mode, in which the wireless remote control 111B is prevented from controlling the battery 125 to supply electric energy and the battery 125 is not in use, to a standby mode, in which the wireless remote control 111B is permitted to control the battery 125 to supply electric energy for the operation of the constriction/stimulation unit 110.



**[00258]** FIGURE 47 shows an embodiment of the invention identical to that of FIGURE 43, except that a motor 115, a mechanical reversing device in the form of a gearbox 127 and a control unit 122 for controlling the gearbox 127 also are implanted in the patient. A separate external wireless remote control 111B controls the implanted control unit 122 to control the gearbox 127 to reverse the function performed by the constriction device (mechanically operated) of the constriction/stimulation unit 110.

**[00259]** FIGURE 48 shows an embodiment of the invention identical to that of FIGURE 46, except that the implanted components are interconnected differently. Thus, in this case, the battery 125 powers the control unit 122 when the accumulator 123, suitably a capacitor, activates the switch 126 to switch to an on mode. When the switch 126 is in its on mode the control unit 122 is permitted to control the battery 125 to supply, or not supply, energy for the operation of the constriction/stimulation unit 110.

**[00260]** FIGURE 49 shows an embodiment of the invention identical to that of FIGURE 39, except that a gearbox 127 that connects the motor 115 to the constriction/stimulation unit 110, and a control unit 122 that controls the energy-transforming device 111A to power the motor 115 also are implanted in the patient. There is a separate external wireless remote control 111B that controls the control unit 122 to reverse the motor 115 when needed.

**[00261]** Optionally, the accumulator 123 shown in FIGURE 42 may be provided in the embodiment of FIGURE 49, wherein the implanted control unit 122 controls the energy-transforming device 111A to store the transformed energy in the accumulator 123. In response to a control signal from the wireless remote control 111B, the control unit 122 controls the accumulator 123 to supply energy for the operation of the constriction/stimulation unit 110.

**[00262]** Those skilled in the art will realise that the above various embodiments according to FIGURES 38-49 could be combined in many different ways. For example, the energy operated switch 114 could be incorporated in any of the embodiments of FIGURES 39, 42-49, the hydraulic shifting device 121 could be incorporated in the embodiment of FIGURE 40, and the gearbox 127 could be incorporated in the embodiment of FIGURE 39. The switch 114 may be of a type that includes electronic components, for example a microprocessor, or a FGPA (Field Programmable Gate Array) designed for switching. Alternatively, however, the

energy operated switch 114 may be replaced by a subcutaneously implanted push button that is manually switched by the patient between "on" and "off".

**[00263]** Alternatively, a permanent or rechargeable battery may be substituted for the energy-transforming devices 111A of the embodiments shown in FIGURES 38-49.

**[00264]** FIGURE 50 shows the energy-transforming device in the form of an electrical junction element 128 for use in any of the above embodiments according to FIGURES 37-49. The element 128 is a flat p-n junction element comprising a p-type semiconductor layer 129 and an n-type semiconductor layer 130 sandwiched together. A light bulb 131 is electrically connected to opposite sides of the element 128 to illustrate how the generated current is obtained. The output of current from such a p-n junction element 128 is correlated to the temperature. See the formula below.

$$I = I_0 (\exp(qV/kT)-1)$$

Where

I is the external current flow,

$I_0$  is the reverse saturation current,

q is the fundamental electronic charge of  $1.602 \times 10^{-19}$  coulombs,

V is the applied voltage,

k is the Boltzmann constant, and

T is the absolute temperature.

**[00265]** Under large negative applied voltage (reverse bias), the exponential term becomes negligible compared to 1.0, and I is approximately  $-I_0$ .  $I_0$  is strongly dependent on the temperature of the junction and hence on the intrinsic-carrier concentration.  $I_0$  is larger for materials with smaller bandgaps than for those with larger bandgaps. The rectifier action of the diode, that is, its restriction of current flow to only one direction, is in this particular embodiment the key to the operation of the p-n junction element 128.

**[00266]** The alternative way to design a p-n junction element is to deposit a thin layer of semiconductor onto a supporting material which does not absorb the kind of energy utilised in the respective embodiments. For use with wirelessly transmitted energy in terms of light waves, glass could be a suitable material. Various materials may be used in the semiconductor layers, such as, but not limited to, cadmium

telluride, copper-indium-diselenide and silicon. It is also possible to use a multilayer structure with several layers of p and n-type materials to improve efficiency.

**[00267]** The electric energy generated by the p-n junction element 128 could be of the same type as generated by solar cells, in which the negative and positive fields create a direct current. Alternatively, the negative and positive semiconductor layers may change polarity following the transmitted waves, thereby generating the alternating current.

**[00268]** The p-n junction element 128 is designed to make it suited for implantation. Thus, all the external surfaces of the element 128 in contact with the human body are made of a biocompatible material. The p-n junction semiconductors are designed to operate optimally at a body temperature of 37°C because the current output, which should be more than 1  $\mu\text{A}$ , is significantly dependent upon such temperature, as shown above. Since both the skin and subcutis absorb energy, the relation between the sensitivity or working area of the element 128 and the intensity or strength of the wireless energy-transmission is considered. The p-n junction element 128 preferably is designed flat and small. Alternatively, if the element 128 is made in larger sizes it should be flexible, in order to adapt to the patient's body movements. The volume of the element 128 should be kept less than 2000  $\text{cm}^3$ .

**[00269]** FIGURE 51 shows basic parts of a remote control of the apparatus of the invention for controlling the constriction/stimulation unit 110. In this case, the stimulation device of the constriction/stimulation unit stimulates the wall portion with electric pulses. The remote control is based on wireless transmission of electromagnetic wave signals, often of high frequencies in the order of 100 kHz - 1 GHz, through the skin 132 of the patient. In FIGURE 51, all parts placed to the left of the skin 132 are located outside the patient's body and all parts placed to the right of the skin 132 are implanted.

**[00270]** An external signal-transmission device 133 is to be positioned close to a signal-receiving device 134 implanted close to the skin 132. As an alternative, the signal-receiving device 134 may be placed for example inside the abdomen of the patient. The signal-receiving device 134 comprises a coil, approximately 1-100 mm, preferably 25 mm in diameter, wound with a very thin wire and tuned with a capacitor to a specific high frequency. A small coil is chosen if it is to be implanted under the skin of the patient and a large coil is chosen if it is to be implanted in the abdomen of

the patient. The signal transmission device 133 comprises a coil having about the same size as the coil of the signal-receiving device 134 but wound with a thick wire that can handle the larger currents that is necessary. The coil of the signal transmission device 133 is tuned to the same specific high frequency as the coil of the signal-receiving device 134.

**[00271]** The signal-transmission device 133 is adapted to send digital information via the power amplifier and signal-receiving device 134 to an implanted control unit 135. To avoid that accidental random high frequency fields trigger control commands, digital signal codes are used. A conventional keypad placed on the signal transmission device 133 is used to order the signal transmission device 133 to send digital signals for the control of the constriction/stimulation unit. The signal transmission device 133 starts a command by generating a high frequency signal. After a short time, when the signal has energized the implanted parts of the control system, commands are sent to operate the constriction device of the constriction/stimulation unit 110 in predefined steps. The commands are sent as digital packets in the form illustrated below.

Start pattern, 8 bits	Command, 8 bits	Count, 8 bits	Checksum, 8 bits
--------------------------	--------------------	------------------	---------------------

**[00272]** The commands are sent continuously during a rather long time period (e.g., about 30 seconds or more). When a new constriction or release step is desired, the Count byte is increased by one to allow the implanted control unit 135 to decode and understand that another step is demanded by the signal transmission device 133. If any part of the digital packet is erroneous, its content is simply ignored.

**[00273]** Through a line 136, an implanted energizer unit 137 draws energy from the high frequency electromagnetic wave signals received by the signal-receiving device 134. The energizer unit 137 stores the energy in a source of energy, such as a large capacitor, powers the control unit 135 and powers the constriction/stimulation unit 110 via a line 138.

**[00274]** The control unit 135 comprises a demodulator and a microprocessor. The demodulator demodulates digital signals sent from the signal transmission device 133. The microprocessor receives the digital packet, decodes it and sends a control signal via a signal line 139 to control the constriction device of the constriction/stimulation unit 110 to either constrict or release the wall portion of the patient's urethra, ureter, renal pelvis or bladder depending on the received command code.

**[00275]** FIGURE 52 shows a circuitry of an embodiment of the invention, in which wireless energy is transformed into a current. External components of the circuitry include a microprocessor 140, a signal generator 141 and a power amplifier 142 connected thereto. The microprocessor 140 is adapted to switch the signal generator 141 on/off and to modulate signals generated by the signal generator 141 with digital commands. The power amplifier 142 amplifies the signals and sends them to an external signal-transmitting antenna coil 143. The antenna coil 143 is connected in parallel with a capacitor 144 to form a resonant circuit tuned to the frequency generated by the signal generator 141.

**[00276]** Implanted components of the circuitry include a signal receiving antenna coil 145 and a capacitor 146 forming together a resonant circuit that is tuned to the same frequency as the transmitting antenna coil 143. The signal receiving antenna coil 145 induces a current from the received high frequency electromagnetic waves and a rectifying diode 147 rectifies the induced current, which charges a storage capacitor 148. The storage capacitor 148 powers a motor 149 for driving the constriction device of the constriction/stimulation unit 110. A coil 150 connected between the antenna coil 145 and the diode 147 prevents the capacitor 148 and the diode 147 from loading the circuit of the signal-receiving antenna 145 at higher frequencies. Thus, the coil 150 makes it possible to charge the capacitor 148 and to transmit digital information using amplitude modulation.

**[00277]** A capacitor 151 and a resistor 152 connected in parallel and a diode 153 form a detector used to detect amplitude modulated digital information. A filter circuit is formed by a resistor 154 connected in series with a resistor 155 connected in series with a capacitor 156 connected in series with the resistor 154 via ground, and a capacitor 157, one terminal of which is connected between the resistors 154,155 and the other terminal of which is connected between the diode 153 and the circuit formed by the capacitor 151 and resistor 152. The filter circuit is used to filter

out undesired low and high frequencies. The detected and filtered signals are fed to an implanted microprocessor 158 that decodes the digital information and controls the motor 149 via an H-bridge 159 comprising transistors 160, 161, 162 and 163. The motor 149 can be driven in two opposite directions by the H-bridge 159.

**[00278]** The microprocessor 158 also monitors the amount of stored energy in the storage capacitor 148. Before sending signals to activate the motor 149, the microprocessor 158 checks whether the energy stored in the storage capacitor 148 is enough. If the stored energy is not enough to perform the requested operation, the microprocessor 158 waits for the received signals to charge the storage capacitor 148 before activating the motor 149.

**[00279]** Alternatively, the energy stored in the storage capacitor 148 may only be used for powering a switch, and the energy for powering the motor 149 may be obtained from another implanted energy source of relatively high capacity, for example a battery. In this case the switch is adapted to connect the battery to the motor 149 in an on mode when the switch is powered by the storage capacitor 148 and to keep the battery disconnected from the motor 149 in a standby mode when the switch is not powered.

**[00280]** FIGURES 53A – 53C show an embodiment of the invention, which is similar to the embodiment of FIGURE 2, except that the constriction/stimulation unit, here denoted by reference numeral 200, is provided with additional clamping elements. The embodiment of FIGURES 53A – 53C is suited for actively moving the urine in the urinary passageway of a patient's urethra, ureter, renal pelvis or bladder. Thus, the constriction/stimulation unit 200 also includes a first pair of short clamping elements 201 and 202, and a second pair of short clamping elements 203 and 204, wherein the first and second pairs of clamping elements are positioned at mutual sides of the elongate clamping elements 5, 6. The two short clamping elements 201, 202 of the first pair are radially movable towards and away from each other between retracted positions (FIGURE 53A) and clamping positions (FIGURES 53B and 53C), and the two short clamping elements 203, 204 of the second pair are radially movable towards and away from each other between retracted positions (FIGURE 53C) and clamping positions (FIGURES 53A and 53B). The stimulation device 3 also includes electrical elements 7 positioned on the short clamping elements 201 - 204, so that the electrical elements 7 on one of the short clamping elements 201 and 203, respectively, of each pair of short elements face the electrical elements 7 on the

other short clamping element 202 and 204, respectively, of each pair of short elements.

**[00281]** The constriction/stimulation unit 200 is applied on a portion 8 of the tissue wall of a patient's urethra, ureter, renal pelvis or bladder, so that the short clamping elements 201, 202 are positioned at an upstream end of the wall portion 8, whereas the short clamping elements 203, 204 202 are positioned at a downstream end of the wall portion 8. In FIGURES 53A to 53C the upstream end of the wall portion 8 is to the left and the downstream end of the wall portion 8 is to the right.

**[00282]** The control device 4 controls the pair of short clamping elements 201, 202, the pair of elongate clamping elements 5, 6 and the pair of short elements 203, 204 to constrict and release the wall portion 8 independently of one another. The control device also controls the electrical elements 7 on a clamping element that is constricting the wall portion to stimulate the constricted wall portion 8 with electric pulses to cause contraction of the wall portion 8, so that the urinary passageway of the wall portion 8 is closed.

**[00283]** FIGURES 53A – 53C illustrate how the control device 4 controls the operation of the constriction/stimulation unit 200 to cyclically move urine downstream in the urinary passageway of the wall portion 8. Thus, in FIGURE 53A the short clamping elements 201, 202 and the elongate clamping elements 5, 6 are in their retracted positions, whereas the short clamping elements 203, 204 are in their clamping positions while the electrical elements 7 on elements 203, 204 electrically stimulate the wall portion 8. The electrical stimulation causes the wall portion 8 at the elements 203, 204 to thicken, whereby the urinary passageway is closed. FIGURE 53B illustrates how also the short clamping elements 201, 202 have been moved radially inwardly to their clamping positions, while the electrical elements 7 on elements 201, 202 electrically stimulate the wall portion 8, whereby a volume of urine is trapped in the urinary passageway between the upstream and downstream ends of the wall portion 8. FIGURE 53C illustrates how initially the short clamping elements 203, 204 have been moved radially outwardly to their retracted positions, and then the elongate clamping elements 5, 6 have been moved radially inwardly to their clamping positions while the electrical elements 7 on elements 5, 6 electrically stimulate the wall portion 8. As a result, the urine in the urinary passageway between the upstream and downstream ends of the wall portion 8 has been moved downstream in the urinary passageway Then, the control device 4 controls the

constriction/stimulation unit 200 to assume the state shown in FIGURE 53A, whereby urine may flow into and fill the urinary passageway between the upstream and downstream ends of the wall portion 8, so that the cycle of the operation is completed.

**[00284]** Alternatively, the operation cycle of the constriction/stimulation unit 200 described above may be reversed, in order to move urine upstream in the urinary passageway. In this case, the control device 4 controls the short clamping elements 203, 204 to constrict the wall portion 8 at the downstream end thereof to restrict the flow of urine and controls the electric elements 7 to stimulate the constricted wall portion 8 with electric pulses at the downstream end to close the urinary passageway. With the urinary passageway closed at the downstream end of the constricted wall portion 8 and the short clamping elements 201, 202 in their retracted positions, as shown in FIGURE 53A, the control device 4 controls the elongate clamping elements 5, 6 to constrict the wall portion 8 between the upstream and downstream ends thereof. As a result, the urine contained in the wall portion 8 between the upstream and downstream ends thereof is moved upstream in the urinary passageway.

**[00285]** Although FIGURES 53A – 53C disclose pairs of clamping elements, it should be noted that it is conceivable to design the constriction/stimulation unit 200 with only a single short clamping element 201, a single elongate clamping element 5 and a single short clamping element 203. In this case the bottom of the tubular wall portion 8 is supported by stationary elements of the constriction/stimulation unit 200 opposite to the clamping elements 201, 5, and 203.

**[00286]** FIGURES 54A and 54B schematically show another embodiment of the invention, in which a constriction/stimulation unit 205 is designed for actively moving the urine in the urinary passageway of a patient's urethra, ureter, renal pelvis or bladder. The constriction device 206 of the constriction/stimulation unit 205 includes a rotor 207, which carries three cylindrical constriction elements 208A, 208B and 208C positioned equidistantly from the axis 209 of the rotor 207. The constriction elements 208A-208C may be designed as rollers. Each cylindrical element 208A–208C is provided with electrical elements 7. A stationary elongate support element 210 is positioned spaced from but close to the rotor 207 and has a part cylindrical surface 211 concentric with the axis 209 of the rotor 207. The constriction/stimulation unit 205 is applied on a patient's urethra, ureter, renal pelvis



or bladder 212, so that the urethra, ureter, renal pelvis or bladder 212 extends between the support element 210 and the rotor 207.

**[00287]** The control device 4 controls the rotor 207 of the constriction device to rotate, such that the constriction elements 208A-208C successively constrict wall portions of a series of wall portions of the urethra, ureter, renal pelvis or bladder 212 against the elongate support element 210. The electrical elements 7 of the constriction elements 208A-208C stimulate the constricted wall portions with electric pulses so that the wall portions thicken and close the urinary passageway of the urethra, ureter, renal pelvis or bladder 212. FIGURE 54A illustrates how the constriction element 208A has started to constrict the wall of the urethra, ureter, renal pelvis or bladder 212 and how the urinary passageway of the urethra, ureter, renal pelvis or bladder 212 is closed with the aid of the electrical elements 7 on the constriction element 208A, whereas the constriction element 208B is about to release the urethra, ureter, renal pelvis or bladder 212. FIGURE 54B illustrates how the constriction element 208A has advanced about halfway along the elongate support element 210 and moved the urine in the urinary passageway in a direction indicated by an arrow. The constriction element 208B has released the urethra, ureter, renal pelvis or bladder 212, whereas the constriction element 208C is about to engage the urethra, ureter, renal pelvis or bladder 212. Thus, the control device 4 controls the rotor 207 to cyclically move the constriction elements 208A-208C, one after the other, along the elongate support element 210, while constricting the wall portions of the urethra, ureter, renal pelvis or bladder 212, so that the urine in the urethra, ureter, renal pelvis or bladder 212 is moved in a peristaltic manner.

**[00288]** FIGURES 55A, 55B and 55C show another mechanically operable constriction device 213 for use in the apparatus of the invention. Referring to FIGURE 55A, the constriction device 213 includes a first ring-shaped holder 214 applied on the urethra, ureter, renal pelvis or bladder 8 of a patient and a second ring-shaped holder 215 also applied on the urethra, ureter, renal pelvis or bladder 8 spaced apart from holder 214. There are elastic strings 216 (here twelve strings) that extend in parallel along the urethra, ureter, renal pelvis or bladder 8 and interconnect the two holders 213, 214 without contacting the urethra, ureter, renal pelvis or bladder 8. FIGURE 55A illustrate an inactivated state of the constriction device 213 in which the urethra, ureter, renal pelvis or bladder 8 is not constricted.

**[00289]** Referring to FIGURES 55B and 55C, when the urethra, ureter, renal pelvis or bladder 8 is to be constricted the ring-shaped holders 213 and 214 are rotated by an operation means (not shown) in opposite directions, whereby the elastic strings 216 constrict the urethra, ureter, renal pelvis or bladder 8 in a manner that appears from FIGURES 55B and 55C. For the sake of clarity, only five strings 216 are shown in FIGURE 55B.

**[00290]** In accordance with the present invention, electrodes for electrically stimulating the urethra, ureter, renal pelvis or bladder 8 to cause contraction of the wall of the urethra, ureter, renal pelvis or bladder 8 are attached to the strings 216 (not shown in FIGURES 55A-55C).

**[00291]** FIGURE 56 schematically illustrates an arrangement of the apparatus that is capable of sending information from inside the patient's body to the outside thereof to give information related to at least one functional parameter of the apparatus, and/or related to a physical parameter of the patient, in order to supply an accurate amount of energy to an implanted internal energy receiver 302 connected to energy consuming components of an implanted constriction/stimulation unit 301 of the apparatus of the invention. Such an energy receiver 302 may include a source of energy and/or an energy-transforming device. Briefly described, wireless energy is transmitted from an external source of energy 304a located outside the patient and is received by the internal energy receiver 302 located inside the patient. The internal energy receiver is adapted to directly or indirectly supply received energy to the energy consuming components of the constriction/stimulation unit 301 via a switch 326. An energy balance is determined between the energy received by the internal energy receiver 302 and the energy used for the constriction/stimulation unit 301, and the transmission of wireless energy is then controlled based on the determined energy balance. The energy balance thus provides an accurate indication of the correct amount of energy needed, which is sufficient to operate the constriction/stimulation unit 301 properly, but without causing undue temperature rise.

**[00292]** In FIGURE 56 the patient's skin is indicated by a vertical line 305. Here, the energy receiver comprises an energy-transforming device 302 located inside the patient, preferably just beneath the patient's skin 305. Generally speaking, the implanted energy-transforming device 302 may be placed in the abdomen, thorax, muscle fascia (e.g. in the abdominal wall), subcutaneously, or at any other

suitable location. The implanted energy-transforming device 302 is adapted to receive wireless energy E transmitted from the external source of energy 304a provided in an external energy-transmission device 304 located outside the patient's skin 305 in the vicinity of the implanted energy-transforming device 302.

**[00293]** As is well known in the art, the wireless energy E may generally be transferred by means of any suitable Transcutaneous Energy Transfer (TET) device, such as a device including a primary coil arranged in the external source of energy 304a and an adjacent secondary coil arranged in the implanted energy-transforming device 302. When an electric current is fed through the primary coil, energy in the form of a voltage is induced in the secondary coil which can be used to power the implanted energy consuming components of the apparatus, e.g. after storing the incoming energy in an implanted source of energy, such as a rechargeable battery or a capacitor. However, the present invention is generally not limited to any particular energy transfer technique, TET devices or energy sources, and any kind of wireless energy may be used.

**[00294]** The amount of energy received by the implanted energy receiver may be compared with the energy used by the implanted components of the apparatus. The term "energy used" is then understood to include also energy stored by implanted components of the apparatus. A control device includes an external control unit 304b that controls the external source of energy 304a based on the determined energy balance to regulate the amount of transferred energy. In order to transfer the correct amount of energy, the energy balance and the required amount of energy is determined by means of a determination device including an implanted internal control unit 315 connected between the switch 326 and the constriction/stimulation unit 301. The internal control unit 315 may thus be arranged to receive various measurements obtained by suitable sensors or the like, not shown, measuring certain characteristics of the constriction/stimulation unit 301, somehow reflecting the required amount of energy needed for proper operation of the constriction/stimulation unit 301. Moreover, the current condition of the patient may also be detected by means of suitable measuring devices or sensors, in order to provide parameters reflecting the patient's condition. Hence, such characteristics and/or parameters may be related to the current state of the constriction/stimulation unit 301, such as power consumption, operational mode and temperature, as well as the patient's condition reflected by parameters such as: body temperature, blood

pressure, heartbeats and breathing. Other kinds of physical parameters of the patient and functional parameters of the device are described elsewhere.

**[00295]** Furthermore, a source of energy in the form of an accumulator 316 may optionally be connected to the implanted energy-transforming device 302 via the control unit 315 for accumulating received energy for later use by the constriction/stimulation unit 301. Alternatively or additionally, characteristics of such an accumulator, also reflecting the required amount of energy, may be measured as well. The accumulator may be replaced by a rechargeable battery, and the measured characteristics may be related to the current state of the battery, any electrical parameter such as energy consumption voltage, temperature, etc. In order to provide sufficient voltage and current to the constriction/stimulation unit 301, and also to avoid excessive heating, it is clearly understood that the battery should be charged optimally by receiving a correct amount of energy from the implanted energy-transforming device 302, i.e. not too little or too much. The accumulator may also be a capacitor with corresponding characteristics.

**[00296]** For example, battery characteristics may be measured on a regular basis to determine the current state of the battery, which then may be stored as state information in a suitable storage means in the internal control unit 315. Thus, whenever new measurements are made, the stored battery state information can be updated accordingly. In this way, the state of the battery can be "calibrated" by transferring a correct amount of energy, so as to maintain the battery in an optimal condition.

**[00297]** Thus, the internal control unit 315 of the determination device is adapted to determine the energy balance and/or the currently required amount of energy, (either energy per time unit or accumulated energy) based on measurements made by the above-mentioned sensors or measuring devices of the apparatus, or the patient, or an implanted source of energy if used, or any combination thereof. The internal control unit 315 is further connected to an internal signal transmitter 327, arranged to transmit a control signal reflecting the determined required amount of energy, to an external signal receiver 304c connected to the external control unit 304b. The amount of energy transmitted from the external source of energy 304a may then be regulated in response to the received control signal.

**[00298]** Alternatively, the determination device may include the external control unit 304b. In this alternative, sensor measurements can be transmitted directly to the external control unit 304b wherein the energy balance and/or the currently required amount of energy can be determined by the external control unit 304b, thus integrating the above-described function of the internal control unit 315 in the external control unit 304b. In that case, the internal control unit 315 can be omitted and the sensor measurements are supplied directly to the internal signal transmitter 327 which sends the measurements over to the external signal receiver 304c and the external control unit 304b. The energy balance and the currently required amount of energy can then be determined by the external control unit 304b based on those sensor measurements.

**[00299]** Hence, the present solution according to the arrangement of FIGURE 56 employs the feed back of information indicating the required energy, which is more efficient than previous solutions because it is based on the actual use of energy that is compared to the received energy, e.g. with respect to the amount of energy, the energy difference, or the energy receiving rate as compared to the energy rate used by implanted energy consuming components of the apparatus. The apparatus may use the received energy either for consuming or for storing the energy in an implanted source of energy or the like. The different parameters discussed above would thus be used if relevant and needed and then as a tool for determining the actual energy balance. However, such parameters may also be needed per se for any actions taken internally to specifically operate the apparatus.

**[00300]** The internal signal transmitter 327 and the external signal receiver 304c may be implemented as separate units using suitable signal transfer means, such as radio, IR (Infrared) or ultrasonic signals. Alternatively, the internal signal transmitter 327 and the external signal receiver 304c may be integrated in the implanted energy-transforming device 302 and the external source of energy 304a, respectively, so as to convey control signals in a reverse direction relative to the energy transfer, basically using the same transmission technique. The control signals may be modulated with respect to frequency, phase or amplitude.

**[00301]** Thus, the feedback information may be transferred either by a separate communication system including receivers and transmitters or may be integrated in the energy system. In accordance with the present invention, such an integrated information feedback and energy system comprises an implantable internal energy

receiver for receiving wireless energy, the energy receiver having an internal first coil and a first electronic circuit connected to the first coil, and an external energy transmitter for transmitting wireless energy, the energy transmitter having an external second coil and a second electronic circuit connected to the second coil. The external second coil of the energy transmitter transmits wireless energy which is received by the first coil of the energy receiver. This system further comprises a power switch for switching the connection of the internal first coil to the first electronic circuit on and off, such that feedback information related to the charging of the first coil is received by the external energy transmitter in the form of an impedance variation in the load of the external second coil, when the power switch switches the connection of the internal first coil to the first electronic circuit on and off. In implementing this system in the arrangement of Fig. 17, the switch 326 is either separate and controlled by the internal control unit 315, or integrated in the internal control unit 315. It should be understood that the switch 326 should be interpreted in its broadest embodiment. This means a transistor, MCU, MCPU, ASIC FPGA or a DA converter or any other electronic component or circuit that may switch the power on and off.

**[00302]** To conclude, the energy supply arrangement illustrated in FIGURE 56 may operate basically in the following manner. The energy balance is first determined by the internal control unit 315 of the determination device. A control signal reflecting the required amount of energy is also created by the internal control unit 315, and the control signal is transmitted from the internal signal transmitter 327 to the external signal receiver 304c. Alternatively, the energy balance can be determined by the external control unit 304b instead depending on the implementation, as mentioned above. In that case, the control signal may carry measurement results from various sensors. The amount of energy emitted from the external source of energy 304a can then be regulated by the external control unit 304b, based on the determined energy balance, e.g. in response to the received control signal. This process may be repeated intermittently at certain intervals during ongoing energy transfer, or may be executed on a more or less continuous basis during the energy transfer.

**[00303]** The amount of transferred energy can generally be regulated by adjusting various transmission parameters in the external source of energy 304a, such as voltage, current, amplitude, wave frequency and pulse characteristics. This

system may also be used to obtain information about the coupling factors between the coils in a TET system even to calibrate the system both to find an optimal place for the external coil in relation to the internal coil and to optimize energy transfer. Simply comparing in this case the amount of energy transferred with the amount of energy received. For example if the external coil is moved the coupling factor may vary and correctly displayed movements could cause the external coil to find the optimal place for energy transfer. Preferably, the external coil is adapted to calibrate the amount of transferred energy to achieve the feedback information in the determination device, before the coupling factor is maximized.

**[00304]** This coupling factor information may also be used as a feedback during energy transfer. In such a case, the energy system of the present invention comprises an implantable internal energy receiver for receiving wireless energy, the energy receiver having an internal first coil and a first electronic circuit connected to the first coil, and an external energy transmitter for transmitting wireless energy, the energy transmitter having an external second coil and a second electronic circuit connected to the second coil. The external second coil of the energy transmitter transmits wireless energy which is received by the first coil of the energy receiver. This system further comprises a feedback device for communicating out the amount of energy received in the first coil as a feedback information, and wherein the second electronic circuit includes a determination device for receiving the feedback information and for comparing the amount of transferred energy by the second coil with the feedback information related to the amount of energy received in the first coil to obtain the coupling factor between the first and second coils. The energy transmitter may regulate the transmitted energy in response to the obtained coupling factor.

**[00305]** With reference to FIGURE 57, although wireless transfer of energy for operating the apparatus has been described above to enable non-invasive operation, it will be appreciated that the apparatus can be operated with wire bound energy as well. Such an example is shown in FIGURE 57, wherein an external switch 326 is interconnected between the external source of energy 304a and an operation device, such as an electric motor 307 operating the constriction/stimulation unit 301. An external control unit 304b controls the operation of the external switch 326 to effect proper operation of the constriction/stimulation unit 301.

**[00306]** FIGURE 58 illustrates different embodiments for how received energy can be supplied to and used by the constriction/stimulation unit 301. Similar to the example of FIGURE 56, an internal energy receiver 302 receives wireless energy E from an external source of energy 304a which is controlled by a transmission control unit 304b. The internal energy receiver 302 may comprise a constant voltage circuit, indicated as a dashed box "constant V" in FIGURE 58, for supplying energy at constant voltage to the constriction/stimulation unit 301. The internal energy receiver 302 may further comprise a constant current circuit, indicated as a dashed box "constant C" in the figure, for supplying energy at constant current to the constriction/stimulation unit 301.

**[00307]** The constriction/stimulation unit 301 comprises an energy consuming part 301a, which may be a motor, pump, restriction device, or any other medical appliance that requires energy for its electrical operation. The constriction/stimulation unit 301 may further comprise an energy storage device 301b for storing energy supplied from the internal energy receiver 302. Thus, the supplied energy may be directly consumed by the energy consuming part 301a, or stored by the energy storage device 301b, or the supplied energy may be partly consumed and partly stored. The constriction/stimulation unit 301 may further comprise an energy stabilizing unit 301c for stabilizing the energy supplied from the internal energy receiver 302. Thus, the energy may be supplied in a fluctuating manner such that it may be necessary to stabilize the energy before consumed or stored.

**[00308]** The energy supplied from the internal energy receiver 302 may further be accumulated and/or stabilized by a separate energy stabilizing unit 328 located outside the constriction/stimulation unit 301, before being consumed and/or stored by the constriction/stimulation unit 301. Alternatively, the energy stabilizing unit 328 may be integrated in the internal energy receiver 302. In either case, the energy stabilizing unit 328 may comprise a constant voltage circuit and/or a constant current circuit.

**[00309]** It should be noted that FIGURE 56 and FIGURE 58 illustrate some possible but non-limiting implementation options regarding how the various shown functional components and elements can be arranged and connected to each other. However, the skilled person will readily appreciate that many variations and modifications can be made within the scope of the present invention.



**[00310]** FIGURE 59 schematically shows an energy balance measuring circuit of one of the proposed designs of the apparatus for controlling transmission of wireless energy, or energy balance. The circuit has an output signal centered on 2.5V and proportionally related to the energy imbalance. The derivative of this signal shows if the value goes up and down and how fast such a change takes place. If the amount of received energy is lower than the energy used by implanted components of the apparatus, more energy is transferred and thus charged into the source of energy. The output signal from the circuit is typically fed to an A/D converter and converted into a digital format. The digital information can then be sent to the external energy-transmission device allowing it to adjust the level of the transmitted energy. Another possibility is to have a completely analog system that uses comparators comparing the energy balance level with certain maximum and minimum thresholds sending information to external energy-transmission device if the balance drifts out of the max/min window.

**[00311]** The schematic FIGURE 59 shows a circuit implementation for a system that transfers energy to the implanted energy components of the apparatus of the present invention from outside of the patient's body using inductive energy transfer. An inductive energy transfer system typically uses an external transmitting coil and an internal receiving coil. The receiving coil, L1, is included in the schematic FIGURE 59; the transmitting parts of the system are excluded.

**[00312]** The implementation of the general concept of energy balance and the way the information is transmitted to the external energy transmitter can of course be implemented in numerous different ways. The schematic FIGURE 20 and the above described method of evaluating and transmitting the information should only be regarded as examples of how to implement the control system.

**[00313]**

**[00314]** CIRCUIT DETAILS

**[00315]** In FIGURE 59 the symbols Y1, Y2, Y3 and so on symbolize test points within the circuit. The components in the diagram and their respective values are values that work in this particular implementation which of course is only one of an infinite number of possible design solutions.

**[00316]** Energy to power the circuit is received by the energy receiving coil L1. Energy to implanted components is transmitted in this particular case at a frequency of 25 kHz. The energy balance output signal is present at test point Y1.

**[00317]**

**[00318]** The embodiments described in connection with FIGURES 56, 58 and 59 identify a general method for controlling transmission of wireless energy to implanted energy consuming components of the apparatus of the present invention. Such a method will be defined in general terms in the following.

**[00319]** A method is thus provided for controlling transmission of wireless energy supplied to implanted energy consuming components of an apparatus as described above. The wireless energy E is transmitted from an external source of energy located outside the patient and is received by an internal energy receiver located inside the patient, the internal energy receiver being connected to the implanted energy consuming components of the apparatus for directly or indirectly supplying received energy thereto. An energy balance is determined between the energy received by the internal energy receiver and the energy used for the operation of the implanted parts of the apparatus. The transmission of wireless energy E from the external source of energy is then controlled based on the determined energy balance.

**[00320]** The wireless energy may be transmitted inductively from a primary coil in the external source of energy to a secondary coil in the internal energy receiver. A change in the energy balance may be detected to control the transmission of wireless energy based on the detected energy balance change. A difference may also be detected between energy received by the internal energy receiver and energy used for the operation of the implanted parts of the apparatus, to control the transmission of wireless energy based on the detected energy difference.

**[00321]** When controlling the energy transmission, the amount of transmitted wireless energy may be decreased if the detected energy balance change implies that the energy balance is increasing, or vice versa. The decrease/increase of energy transmission may further correspond to a detected change rate.

**[00322]** The amount of transmitted wireless energy may further be decreased if the detected energy difference implies that the received energy is greater than the used energy, or vice versa. The decrease/increase of energy transmission may then correspond to the magnitude of the detected energy difference.

**[00323]** As mentioned above, the energy used for the operation of the implanted parts of the apparatus be consumed to operate the implanted parts of the

apparatus and/or stored in at least one implanted energy storage device of the apparatus.

**[00324]** When electrical and/or physical parameters of the implanted parts of the apparatus and/or physical parameters of the patient are determined, the energy may be transmitted for consumption and storage according to a transmission rate per time unit which is determined based on said parameters. The total amount of transmitted energy may also be determined based on said parameters.

**[00325]** When a difference is detected between the total amount of energy received by the internal energy receiver and the total amount of consumed and/or stored energy, and the detected difference is related to the integral over time of at least one measured electrical parameter related to said energy balance, the integral may be determined for a monitored voltage and/or current related to the energy balance.

**[00326]** When the derivative is determined over time of a measured electrical parameter related to the amount of consumed and/or stored energy, the derivative may be determined for a monitored voltage and/or current related to the energy balance.

**[00327]** The transmission of wireless energy from the external source of energy may be controlled by applying to the external source of energy electrical pulses from a first electric circuit to transmit the wireless energy, the electrical pulses having leading and trailing edges, varying the lengths of first time intervals between successive leading and trailing edges of the electrical pulses and/or the lengths of second time intervals between successive trailing and leading edges of the electrical pulses, and transmitting wireless energy, the transmitted energy generated from the electrical pulses having a varied power, the varying of the power depending on the lengths of the first and/or second time intervals.

**[00328]** In that case, the frequency of the electrical pulses may be substantially constant when varying the first and/or second time intervals. When applying electrical pulses, the electrical pulses may remain unchanged, except for varying the first and/or second time intervals. The amplitude of the electrical pulses may be substantially constant when varying the first and/or second time intervals. Further, the electrical pulses may be varied by only varying the lengths of first time intervals between successive leading and trailing edges of the electrical pulses.

**[00329]** A train of two or more electrical pulses may be supplied in a row, wherein when applying the train of pulses, the train having a first electrical pulse at the start of the pulse train and having a second electrical pulse at the end of the pulse train, two or more pulse trains may be supplied in a row, wherein the lengths of the second time intervals between successive trailing edge of the second electrical pulse in a first pulse train and leading edge of the first electrical pulse of a second pulse train are varied

**[00330]** When applying the electrical pulses, the electrical pulses may have a substantially constant current and a substantially constant voltage. The electrical pulses may also have a substantially constant current and a substantially constant voltage. Further, the electrical pulses may also have a substantially constant frequency. The electrical pulses within a pulse train may likewise have a substantially constant frequency.

**[00331]** The circuit formed by the first electric circuit and the external source of energy may have a first characteristic time period or first time constant, and when effectively varying the transmitted energy, such frequency time period may be in the range of the first characteristic time period or time constant or shorter.

**[00332]** The embodiments described in connection with FIGURES 56, 58 and 59 also identify general features for controlling transmission of wireless energy to implanted energy consuming components of the apparatus of the present invention. Such features of the apparatus will be defined in general terms in the following.

**[00333]** In its broadest sense, the apparatus comprises a control device for controlling the transmission of wireless energy from an energy-transmission device, and an implantable internal energy receiver for receiving the transmitted wireless energy, the internal energy receiver being connected to implantable energy consuming components of the apparatus for directly or indirectly supplying received energy thereto. The apparatus further comprises a determination device adapted to determine an energy balance between the energy received by the internal energy receiver and the energy used for the implantable energy consuming components of the apparatus, wherein the control device controls the transmission of wireless energy from the external energy-transmission device, based on the energy balance determined by the determination device.

**[00334]** Further, the apparatus of the invention may comprise any of the following features:

- [00335]** - A primary coil in the external source of energy adapted to transmit the wireless energy inductively to a secondary coil in the internal energy receiver.
- [00336]** - The determination device is adapted to detect a change in the energy balance, and the control device controls the transmission of wireless energy based on the detected energy balance change.
- [00337]** - The determination device is adapted to detect a difference between energy received by the internal energy receiver and energy used for the implantable energy consuming components of the apparatus, and the control device controls the transmission of wireless energy based on the detected energy difference.
- [00338]** - The control device controls the external energy-transmission device to decrease the amount of transmitted wireless energy if the detected energy balance change implies that the energy balance is increasing, or vice versa, wherein the decrease/increase of energy transmission corresponds to a detected change rate.
- [00339]** - The control device controls the external energy-transmission device to decrease the amount of transmitted wireless energy if the detected energy difference implies that the received energy is greater than the used energy, or vice versa, wherein the decrease/increase of energy transmission corresponds to the magnitude of said detected energy difference.
- [00340]** - The energy used for implanted parts of the apparatus is consumed to operate the implanted parts, and/or stored in at least one energy storage device of the apparatus.
- [00341]** - Where electrical and/or physical parameters of the apparatus and/or physical parameters of the patient are determined, the energy-transmission device transmits the energy for consumption and storage according to a transmission rate per time unit which is determined by the determination device based on said parameters. The determination device also determines the total amount of transmitted energy based on said parameters.
- [00342]** - When a difference is detected between the total amount of energy received by the internal energy receiver and the total amount of consumed and/or stored energy, and the detected difference is related to the integral over time of at least one measured electrical parameter related to the energy balance, the determination device determines the integral for a monitored voltage and/or current related to the energy balance.

- [00343]** - When the derivative is determined over time of a measured electrical parameter related to the amount of consumed and/or stored energy, the determination device determines the derivative for a monitored voltage and/or current related to the energy balance.
- [00344]** - The energy-transmission device comprises a coil placed externally to the human body, and an electric circuit is provided to power the external coil with electrical pulses to transmit the wireless energy. The electrical pulses have leading and trailing edges, and the electric circuit is adapted to vary first time intervals between successive leading and trailing edges and/or second time intervals between successive trailing and leading edges of the electrical pulses to vary the power of the transmitted wireless energy. As a result, the energy receiver receiving the transmitted wireless energy has a varied power.
- [00345]** - The electric circuit is adapted to deliver the electrical pulses to remain unchanged except varying the first and/or second time intervals.
- [00346]** - The electric circuit has a time constant and is adapted to vary the first and second time intervals only in the range of the first time constant, so that when the lengths of the first and/or second time intervals are varied, the transmitted power over the coil is varied.
- [00347]** - The electric circuit is adapted to deliver the electrical pulses to be varied by only varying the lengths of first time intervals between successive leading and trailing edges of the electrical pulses.
- [00348]** - The electric circuit is adapted to supplying a train of two or more electrical pulses in a row, said train having a first electrical pulse at the start of the pulse train and having a second electrical pulse at the end of the pulse train, and
- [00349]** - the lengths of the second time intervals between successive trailing edge of the second electrical pulse in a first pulse train and leading edge of the first electrical pulse of a second pulse train are varied by the first electronic circuit.
- [00350]** - The electric circuit is adapted to provide the electrical pulses as pulses having a substantially constant height and/or amplitude and/or intensity and/or voltage and/or current and/or frequency.
- [00351]** - The electric circuit has a time constant, and is adapted to vary the first and second time intervals only in the range of the first time constant, so that when the lengths of the first and/or second time intervals are varied, the transmitted power over the first coil are varied.

**[00352]** - The electric circuit is adapted to provide the electrical pulses varying the lengths of the first and/or the second time intervals only within a range that includes the first time constant or that is located relatively close to the first time constant, compared to the magnitude of the first time constant.

**[00353]** All of the various elements disclosed in the embodiments according to FIGURES 1-59 may be combined as desired, where applicable.

**[00354]** While the invention has been described in connection with what is presently considered to be the most practical and preferred embodiment, it is to be understood that the invention is not to be limited to the disclosed embodiment, but on the contrary, is intended to cover various modifications and equivalent arrangements included within the spirit and scope of the appended claims.

## WHAT IS CLAIMED IS:

1. An apparatus for controlling a flow of **urine in the urethra, ureter, renal pelvis or bladder of a patient**, the apparatus comprising:  
an implantable constriction device for gently constricting at least one portion of the tissue wall of the patient's urethra, ureter, renal pelvis or urine bladder to influence the flow of urine,  
a stimulation device for stimulating the wall portion of the tissue wall, and  
a control device for controlling the stimulation device to stimulate the wall portion, as the constriction device constricts the wall portion, to cause contraction of the wall portion to further influence the flow of urine..
2. The apparatus according to claim 1, wherein said constriction device is adapted to constrict the wall portion to at least restrict the flow of urine, and said control device controls said stimulation device to cause contraction of the constricted wall portion, so that the flow of urine is at least further restricted.
3. The apparatus according to claim 2, wherein the constriction device is adapted to constrict the wall portion to a constricted state in which the blood circulation in the constricted wall portion is substantially unrestricted and the flow of urine is at least restricted, and the control device controls the stimulation device to cause contraction of the wall portion, so that the flow of urine is at least further restricted when the wall portion is kept by the constriction device in the constricted state.
4. The apparatus according to claim 1, wherein the control device controls the constriction device to adjust the constriction of the patient's wall portion.
5. The apparatus according to claim 4, wherein the control device controls the constriction and stimulation devices independently of each other.
6. The apparatus according to claim 5, wherein the control device simultaneously controls the constriction device and the stimulation device.



7. The apparatus according to claim 4, wherein the control device controls the stimulation device to stimulate the wall portion, while the control device controls the constriction device to change the constriction of the wall portion.
8. The apparatus according to claim 4, wherein the control device is adapted to calibrate the constriction device by controlling the stimulation device to stimulate the wall portion while controlling the constriction device to adjust the constriction of the wall portion until the desired restriction of the flow of urine is obtained.
9. The apparatus according to claim 4, wherein the control device controls the stimulation device not to stimulate the wall portion while the control device controls the constriction device to change the constriction of the wall portion.
10. The apparatus according to claim 4, wherein the control device controls the constriction device to constrict the wall portion, such that the flow of urine is restricted but not stopped, and controls the stimulation device to stimulate the constricted wall portion to cause contraction thereof, such that the flow of urine is further restricted but not stopped .
11. The apparatus according to claim 10, wherein the control device controls the stimulation device to adjust the intensity of the stimulation of the wall portion in response to a sensed physical parameter of the patient.
12. The apparatus according to claim 10, wherein the control device controls the stimulation device to adjust the intensity of the stimulation of the wall portion in response to a sensed functional parameter of the apparatus.
13. The apparatus according to claim 10, wherein the control device controls the stimulation device in a first mode to stimulate the constricted wall portion to further restrict but not stop the flow of urine and controls the stimulation device in a second mode to cease the stimulation of the wall portion to increase the flow of urine .
14. The apparatus according to claim 13, wherein the control device in the second mode controls the stimulation device to cease the stimulation of

the wall portion and controls the constriction device to release the wall portion to restore the flow of urine .

15. The apparatus according to claim 4, wherein said control device controls said constriction device to constrict the wall portion, such that the flow of urine is restricted but not stopped, and controls said stimulation device to stimulate the constricted wall portion to cause contraction thereof, such that the flow of urine is stopped.

16. The apparatus according to claim 15, wherein the control device controls the stimulation device in a first mode to stimulate the constricted wall portion to stop the flow of urine and controls the stimulation device in a second mode to cease the stimulation of the wall portion to allow flow of urine.

17. The apparatus according to claim 16, wherein the control device in the second mode controls the stimulation device to cease the stimulation of the wall portion and controls the constriction device to release the wall portion to restore the flow of urine.

18. The apparatus according to claim 15, wherein the control device controls the stimulation device to adjust the intensity of the stimulation of the wall portion in response to a sensed physical parameter of the patient.

19. The apparatus according to claim 15, wherein the control device controls the stimulation device to adjust the intensity of the stimulation of the wall portion in response to a sensed functional parameter of the apparatus.

20. The apparatus according to claim 18, wherein the control device controls the stimulation device to increase the intensity of the stimulation of the wall portion, such that the flow of urine remains stopped when a pressure increase occurs in the urinary passageway.

21. The apparatus according to claim 20, further comprising a sensor for sensing a physical parameter of the patient's body that relates to the pressure in the urinary passageway, wherein the control device controls the stimulation device in response to signals from the sensor.

22. The apparatus according to claim 21, wherein the physical parameter is a pressure in the patient's body and the sensor is a pressure sensor.

23. The apparatus according to claim 4, wherein said control device controls said constriction device to constrict the wall portion, such that the flow of urine is substantially stopped, and controls said stimulation device to stimulate the constricted wall portion to cause contraction thereof, such that the flow of urine is completely stopped.

24. The apparatus according to claim 23, wherein the control device controls the stimulation device in a first mode to stimulate the constricted wall portion to completely stop the flow of urine and controls the stimulation device in a second mode to cease the stimulation of the wall portion to allow flow of urine .

25. The apparatus according to claim 24, wherein the control device in the second mode controls the stimulation device to cease the stimulation of the wall portion and controls the constriction device to release the wall portion to restore the flow of urine .

26. The apparatus according to claim 23, wherein the control device controls the stimulation device to adjust the intensity of the stimulation of the wall portion in response to a sensed physical parameter of the patient.

27. The apparatus according to claim 23, wherein the control device controls the stimulation device to adjust the intensity of the stimulation of the wall portion in response to a sensed functional parameter of the apparatus

28. The apparatus according to claim 26, wherein the control device controls the stimulation device to increase the intensity of the stimulation of the wall portion in response to a sensed pressure increase in the urinary passageway, such that the flow of urine remains stopped.

29. The apparatus according to claim 28, further comprising a sensor for sensing a physical parameter of the patient's body that relates to the pressure in the urinary passageway, wherein the control device controls the stimulation device in response to signals from the sensor.

30. The apparatus according to claim 29, wherein the physical parameter is a pressure in the patient's body and the sensor is a pressure sensor.

31. The apparatus according to claim 4, wherein the control device controls the constriction device to constrict the wall portion, such that the flow of urine is stopped.

32. The apparatus according to claim 31, wherein the control device controls the constriction device in a first mode to constrict the constricted wall portion to stop the flow of urine and controls the constriction device in a second mode to cease the constriction of the wall portion to restore flow of urine .

33. The apparatus according to claim 31, wherein the control device controls the stimulation device to stimulate the constricted wall portion to cause contraction thereof, such that the flow of urine remains stopped when a pressure increase occurs in the urinary passageway.

34. The apparatus according to claim 33, further comprising a sensor for sensing a physical parameter of the patient's body that relates to the pressure in the urinary passageway, wherein the control device controls the stimulation device in response to signals from the sensor.

35. The apparatus according to claim 34, wherein the physical parameter is a pressure in the patient's body and the sensor is a pressure sensor.

36. The apparatus according to claim 4, wherein the control device controls the constriction device and/or the stimulation device from outside the patient's body.

37. The apparatus according to claim 36, wherein the control device is operable by the patient.

38. The apparatus according to claim 37, wherein the control device comprises a manually operable switch for switching on and off the constriction device and/or stimulation device, the switch being adapted for subcutaneous

implantation in the patient to be manually operated from outside the patient's body.

39. The apparatus according to claim 37, wherein the control device comprises a hand-held wireless remote control operable by the patient to switch on and off the constriction device and/or stimulation device.

40. The apparatus according to claim 36, wherein the control device wirelessly controls the constriction device and/or stimulation device.

41. The apparatus according to claim 40, wherein the control device wirelessly controls the constriction device in a non-magnetic manner.

42. The apparatus according to claim 1, wherein the constriction device is designed to normally keep the patient's wall portion in a constricted state, in which the blood circulation in the constricted wall portion is substantially unrestricted and the flow of urine is at least restricted.

43. The apparatus according to claim 42, wherein the control device controls the stimulation device to stimulate the constricted wall portion to cause contraction thereof, such that the outlet opening is reduced to further restrict but not stop the flow of urine.

44. The apparatus according to claim 43, wherein the control device controls the stimulation device to adjust the intensity of the stimulation of the wall portion in response to a sensed physical parameter of the patient or functional parameter of the apparatus.

45. The apparatus according to claim 43, wherein the control device controls the stimulation device in a first mode to stimulate the constricted wall portion to further restrict the flow of urine and controls the stimulation device in a second mode to cease the stimulation of the wall portion to increase the flow of urine.

46. The apparatus according to claim 42, wherein the control device controls the stimulation device to stimulate the constricted wall portion to cause contraction thereof, such that the flow of urine is stopped.

47. The apparatus according to claim 46, wherein the control device controls the stimulation device to adjust the intensity of the stimulation of the

wall portion in response to a sensed physical parameter of the patient or functional parameter of the apparatus.

48. The apparatus according to claim 47, wherein the control device controls the stimulation device to increase the intensity of the stimulation, such that the flow of urine remains stopped when a pressure increase occurs in the urinary passageway.

49. The apparatus according to claim 48, further comprising a sensor for sensing a physical parameter of the patient that relates to the pressure in the urinary passageway, wherein the control device controls the stimulation device in response to signals from the sensor.

50. The apparatus according to claim 49, wherein the physical parameter is a pressure in the patient's body and the sensor is a pressure sensor.

51. The apparatus according to claim 46, wherein the control device controls the stimulation device in a first mode to stimulate the constricted wall portion to stop the flow of urine and controls the stimulation device in a second mode to cease the stimulation of the wall portion to allow flow of urine.

52. The apparatus according to claim 42, wherein the control device controls the stimulation device from outside the patient's body.

53. The apparatus according to claim 52, wherein the control device is operable by the patient.

54. The apparatus according to claim 53, wherein the control device comprises a manually operable switch for switching on and off the stimulation device, the switch being adapted for subcutaneous implantation in the patient to be manually operated from outside the patient's body.

55. The apparatus according to claim 53, wherein the control device comprises a hand-held wireless remote control operable by the patient to switch on and off the stimulation device.

56. The apparatus according to claim 52, wherein the control device wirelessly controls the stimulation device.

57. The apparatus according to claim 1, wherein the control device controls the stimulation device to intermittently and individually stimulate different areas of the wall portion, such that at least two of the areas are stimulated at different points of time.

58. The apparatus according to claim 57, wherein the control device controls the stimulation device to intermittently stimulate each area of the different areas of the wall portion during successive time periods, each time period being short enough to maintain over time satisfactory blood circulation in the area until the lapse of the time period.

59. The apparatus according to claim 57, wherein the control device controls the stimulation device to intermittently stimulate the areas of the wall portion, such that an area of the wall portion that currently is not stimulated has time to restore substantially normal blood circulation before the stimulation device stimulates the area again.

60. The apparatus according to claim 1, wherein the control device controls the stimulation device to stimulate one or more different areas of the wall portion at a time.

61. The apparatus according to claim 60, wherein the control device controls the stimulation device to sequentially stimulate the different areas of the wall portion.

62. The apparatus according to claim 60, wherein the control device controls the stimulation device to shift over time the stimulation from one area to another.

63. The apparatus according to claim 62, wherein the control device controls the stimulation device to cyclically propagate the stimulation of the areas along the wall portion in the same or opposite direction of the flow in the patient's urinary passageway .

64. The apparatus according to claim 63, wherein the control device controls the stimulation device to propagate the stimulation of the areas in accordance with a determined stimulation pattern.

65. The apparatus according to claim 1, wherein the control device controls the stimulation device to vary the intensity of the stimulation of the wall portion.

66. The apparatus according to claim 65, wherein the control device controls the stimulation device to cyclically vary the intensity of the stimulation of the wall portion.

67. The apparatus according to claim 1, wherein the control device controls the stimulation device to intermittently and individually stimulate different areas of the wall portion with pulses.

68. The apparatus according to claim 67, wherein the control device controls the stimulation device to intermittently stimulate the areas with the pulses.

69. The apparatus according to claim 67, wherein the pulses form pulse trains.

70. The apparatus according to claim 69, wherein at least a first area and a second area of the areas of the wall portion are repeatedly stimulated with a first pulse train and a second pulse train, respectively, such that the first and second pulse trains over time are shifted relative to each other.

71. The apparatus according to claim 70, wherein the first area is stimulated with the first pulse train while the second area is not stimulated with the second pulse train, and vice versa.

72. The apparatus according to claim 70, wherein the first and second pulse trains are shifted relative to each other such that the first and second pulse trains at least partially overlap each other.

73. The apparatus according to claim 69, wherein the control device controls the stimulation device to vary the amplitudes of the pulses of the pulse trains.

74. The apparatus according to claim 69, wherein the control device controls the stimulation device to vary the off time periods between the individual pulses of each pulse train.



75. The apparatus according to claim 69, wherein the control device controls the stimulation device to vary the width of each pulse of the pulse trains.

76. The apparatus according to claim 69, wherein the control device controls the stimulation device to vary the frequency of the pulses of the pulse trains.

77. The apparatus according to claim 69, wherein the control device controls the stimulation device to vary the off time periods between the pulse trains.

78. The apparatus according to claim 77, wherein the control device controls the stimulation device to keep each off time period between the pulse trains long enough to restore substantially normal blood circulation in each area when the area is not stimulated during the off time periods.

79. The apparatus according to claim 69, wherein the control device controls the stimulation device to vary the length of each pulse train.

80. The apparatus according to claim 69, wherein the control device controls the stimulation device to vary the frequency of the pulse trains.

81. The apparatus according to claim 69, wherein the control device controls the stimulation device to vary the number of pulses of each pulse train.

82. The apparatus according to claim 1, wherein the stimulation device intermittently and individually electrically stimulates different areas of the patient's wall portion.

83. The apparatus according to claim 82, wherein the stimulation device stimulates the areas of the patient's wall portion with electric pulses.

84. The apparatus according to claim 83, wherein the wall portion includes muscle fibers and the stimulation device stimulates the wall portion including the muscle fibers with electric pulses, to cause contraction of the muscle fibres to contract the wall portion.

85. The apparatus according to claim 82, wherein the stimulation device comprises at least one electrical element for engaging the wall portion and for stimulating the wall portion with electric pulses.
86. The apparatus according to claim 85, wherein the stimulation device comprises a plurality of electrical elements.
87. The apparatus according to claim 86, wherein the electrical elements are placed in a fixed orientation relative to one another.
88. The apparatus according to claim 87, wherein the stimulation device comprises a structure holding the electrical elements in the fixed orientation.
89. The apparatus according to claim 88, wherein the electrical elements form an elongate pattern of electrical elements, and the structure is applicable on the patient's urethra, ureter, renal pelvis or urine bladder such that the elongate pattern of electrical elements extends along the wall portion of the urethra, ureter, renal pelvis or urine bladder in the direction of the flow of urine and the elements abut the respective areas of the wall portion.
90. The apparatus according to claim 88, wherein the structure is integrated in the constriction device.
91. The apparatus according to claim 88, wherein the structure is separate from the constriction device.
92. The apparatus according to claim 86, wherein the control device controls the stimulation device to electrically energize the electrical elements.
93. The apparatus according to claim 92, wherein the control device controls the stimulation device to cyclically energize each element with electric pulses.
94. The apparatus according to claim 93, wherein the control device controls the stimulation device to energize the electrical elements, such that a number or groups of the electrical elements are energized at the same time.
95. The apparatus according to claim 93, wherein the control device controls the stimulation device to energize the electrical elements, such that the electrical elements are energized one at a time in sequence or groups of

the electrical elements are sequentially energized, either randomly or in accordance with a predetermined pattern.

96. The apparatus according to claim 93, wherein the electrical elements form an elongate pattern of electrical elements, and the elements are applicable on the patient's wall such that the elongate pattern of electrical elements extends along the wall portion of the urethra, ureter, renal pelvis or urine bladder in the direction of the flow of urine and the elements about the respective areas of the wall portion.

97. The apparatus according to claim 96, wherein the control device controls the stimulation device to successively energize the electrical elements longitudinally along the elongate pattern of electrical elements.

98. The apparatus according to claim 97, wherein the control device controls the stimulation device to successively energize the electrical elements along the elongate pattern of electrical elements in a direction opposite to, or in the same direction as, that of the flow of urine, when the stimulation device is applied on the patient's urethra, ureter, renal pelvis or urine bladder.

99. The apparatus according to claim 97, wherein the control device controls the stimulation device to successively energize the electrical elements from a position substantially at the center of the constricted wall portion towards both ends of the elongate pattern of electrical elements, when the stimulation device is applied on the patient's urethra, ureter, renal pelvis or urine bladder.

100. The apparatus according to claim 97, wherein the control device controls the stimulation device to energize the electrical elements, such that electrical elements currently energized form at least one group of adjacent energized electrical elements.

101. The apparatus according to claim 100, wherein the elements in the group of energized electrical elements form a path of energized electrical elements.

102. The apparatus according to claim 101, wherein the path of energized electrical elements extends at least in part around the patient's

urethra, ureter, renal pelvis or urine bladder, when the stimulation device is applied on the urethra, ureter, renal pelvis or urine bladder.

103. The apparatus according to claim 102, wherein the path of energized electrical elements extends completely around the patient's urethra, ureter, renal pelvis or urine bladder, when the stimulation device is applied on the urethra, ureter, renal pelvis or urine bladder.

104. The apparatus according to claim 100, wherein the elements in the group of energized electrical elements form two paths of energized electrical elements extending opposite to each other, when the stimulation device is applied on the patient's urethra, ureter, renal pelvis or urine bladder.

105. The apparatus according to claim 104, wherein the two paths of energized electrical elements extend on mutual sides of the patient's urethra, ureter, renal pelvis or urine bladder and at least substantially transverse to the direction of flow in the patient's urinary passageway, when the stimulation device is applied on the urethra, ureter, renal pelvis or urine bladder.

106. The apparatus according to claim 92, wherein the electrical elements form a plurality of groups of elements, the groups forming a series of groups extending along the patient's urethra, ureter, renal pelvis or urine bladder in the direction of flow in the patient's urinary passageway, when the stimulation device is applied on the urethra, ureter, renal pelvis or urine bladder.

107. The apparatus according to claim 106, wherein the control device controls the stimulation device to successively energize the groups of electrical elements in the series of groups in a direction opposite to, or in the same direction as, that of the flow of urine, when the stimulation device is applied on the patient's urethra, ureter, renal pelvis or urine bladder.

108. The apparatus according to claim 106, wherein the control device controls the stimulation device to successively energize the groups of electrical elements in the series of groups from a position substantially at the center of the constricted wall portion in a direction opposite to, and in the same direction as, that of the flow of urine, when the stimulation device is applied on the patient's urethra, ureter, renal pelvis or urine bladder.

109. The apparatus according to claim 106, wherein the electrical elements of each group of electrical elements form a path of elements extending at least in part around the patient's urethra, ureter, renal pelvis or urine bladder, when the stimulation device is applied on the urethra, ureter, renal pelvis or urine bladder.

110. The apparatus according to claim 109, wherein the path of electrical elements of each group of elements extends completely around the patient's urethra, ureter, renal pelvis or urine bladder, when the stimulation device is applied on the urethra, ureter, renal pelvis or urine bladder.

111. The apparatus according to claim 106, wherein the electrical elements of each group of electrical elements form two paths of elements extending on mutual sides of the patient's urethra, ureter, renal pelvis or urine bladder, when the stimulation device is applied on the urethra, ureter, renal pelvis or urine bladder.

112. The apparatus according to claim 111, wherein the two paths of electrical elements of each group of elements extend at least substantially transverse to the direction of flow of urine, when the stimulation device is applied on the patient's urethra, ureter, renal pelvis or urine bladder.

113. The apparatus according to claim 1, wherein the stimulation device thermally stimulates the wall portion.

114. The apparatus according to claim 113, wherein said control device controls said stimulation device to cool the constricted wall portion to cause contraction of the wall portion.

115. The apparatus according to claim 114, wherein said constriction device is adapted to constrict the wall portion to at least restrict the flow in the urinary passageway, and said control device controls said stimulation device to cool the constricted wall portion to cause contraction thereof, such that the flow in the urinary passageway is at least further restricted.

116. The apparatus according to claim 115, wherein the control device controls the stimulation device to cool the wall portion to cause contraction thereof, such that the flow in the urinary passageway is further restricted but not stopped.

117. The apparatus according to claim 115, wherein the control device controls the stimulation device to cool the wall portion to cause contraction thereof, such that the flow in the urinary passageway is stopped.

118. The apparatus according to claim 113, wherein the control device controls the stimulation device to heat the wall portion, when the wall portion is constricted and contracted, to cause expansion of the wall portion.

119. The apparatus according to claim 118, wherein said control device controls said stimulation device to heat the wall portion, when the wall portion is constricted and contracted, to cause expansion of the wall portion..

120. The apparatus according to claim 113, wherein the control device controls the constriction device and/or the stimulation device from outside the patient's body.

121. The apparatus according to claim 1, wherein the control device comprises an internal control unit implantable in the patient for controlling the constriction device and/or stimulation device.

122. The apparatus according to claim 121, wherein the internal control unit is programmable.

123. The apparatus according to claim 122, wherein the control device comprises an external control unit intended to be outside the patient's body for controlling the constriction device and/or stimulation device.

124. The apparatus according to claim 123, wherein the internal control unit is programmable by the external control unit.

125. The apparatus according to claim 123, wherein the internal control unit is programmable for controlling the constriction device and/or stimulation device over time.

126. The apparatus according to claim 125, wherein the internal control unit controls the constriction device over time in accordance with an activity schedule program.

127. The apparatus according to claim 123, wherein the internal control unit comprises a microprocessor.

128. The apparatus according to claim 1, further comprising at least one implantable sensor, wherein the control device controls the constriction device and/or the stimulation device in response to signals from the sensor.

129. The apparatus according to claim 128, wherein the sensor directly or indirectly senses at least one physical parameter of the patient.

130. The apparatus according to claim 129, wherein the sensor directly or indirectly senses at least one functional parameter of a medical implant.

131. The apparatus according to claim 129, wherein the sensor comprises a pressure sensor for sensing as the physical parameter a pressure in the patient's body.

132. The apparatus according to claim 131, wherein the control device controls the constriction device and/or stimulation device to change the constriction of the patient's wall portion in response to the pressure sensor sensing a predetermined value of measured pressure.

133. The apparatus according to claim 128, wherein the control device comprises an implantable internal control unit directly controlling the constriction device and/or stimulation device in response to signals from the sensor.

134. The apparatus according to claim 128, wherein the control device comprises an external control unit outside the patient's body for controlling the constriction device and/or stimulation device in response to signals from the sensor.

135. The apparatus according to claim 129, wherein the control device produces an indication in response to the signals from the sensor.

136. The apparatus according to claim 135, wherein the indication comprises a sound signal or displayed information.

137. The apparatus according to claim 1, wherein the constriction device and stimulation device co-operate to move the urinary contents in the urinary passageway.

138. The apparatus according to claim 137, wherein the constriction device is adapted to constrict the wall portion to restrict the flow of urine, and the control device controls the stimulation device to progressively stimulate the constricted wall portion to cause progressive contraction of the wall portion to move the urinary contents in the urinary passageway.

139. The apparatus according to claim 137, wherein the control device controls the stimulation device to progressively stimulate the constricted wall portion in the downstream or upstream direction of the urinary passageway.

140. The apparatus according to claim 137, wherein the constriction device is adapted to constrict the wall portion to restrict the flow of urine, and the control device controls the stimulation device to stimulate the constricted wall portion to close the urinary passageway either at an upstream end or a downstream end of the wall portion and simultaneously controls the constriction device to increase the constriction of the wall portion to move the urinary contents in the urinary passageway.

141. The apparatus according to claim 137, wherein the control device controls the constriction device to vary the constriction of the wall portion and simultaneously controls the stimulation device to progressively stimulate the constricted wall portion to cause progressive contraction of the wall portion to move the urinary contents in the urinary passageway.

142. The apparatus according to claim 141, wherein the control device controls the stimulation device to progressively stimulate the constricted wall portion in the downstream or upstream direction of the urinary passageway.

143. The apparatus according to claim 136, wherein the control device controls the stimulation device to stimulate the wall portion and simultaneously controls the constriction device to vary the constriction of different areas of the wall portion such that the wall portion is progressively constricted in the downstream or upstream direction of the urinary passageway.



144. The apparatus according to claim 143, wherein the control device controls the stimulation device to progressively stimulate the constricted wall portion to cause progressive contraction thereof in harmony with the progressive constriction of the wall portion performed by the constriction device.

145. The apparatus according to claim 143, wherein the constriction device comprises at least one elongated constriction element extending along the wall portion, and the control device controls the elongated constriction element to progressively constrict the wall portion in the downstream or upstream direction of the urinary passageway.

146. The apparatus according to claim 145, wherein the elongated constriction element comprises contact surfaces dimensioned to contact a length of the wall portion, when the constriction device constricts the wall portion, and the stimulation device comprises a plurality of stimulation elements distributed along the contact surfaces, such that the stimulation elements stimulate the different areas of the wall portion along the length of the wall portion, when the control device controls the stimulation device to stimulate the wall portion.

147. The apparatus according to claim 137, wherein said constriction device is adapted to constrict any one of a series of wall portions of the tissue wall to at least restrict the flow of urine, said stimulation device stimulates the wall portion constricted by said constriction device to close the urinary passageway, and said control device controls said constriction device to successively constrict the wall portions of the series of wall portions to move the urinary contents in the urinary passageway in a peristaltic manner.

148. The apparatus according to claim 147, wherein the constriction device comprises at least one constriction element that is moveable along the urethra, ureter, renal pelvis or urine bladder to successively constrict the wall portions of the series of wall portions of the urethra, ureter, renal pelvis or urine bladder, and the stimulation device comprises at least one stimulation element positioned on the constriction element for stimulating the wall portion constricted by the constriction element to close the urinary passageway.

149. The apparatus according to claim 148, wherein the control device controls the constriction device to cyclically move the constriction element along the wall portions of the series of wall portions.

150. The apparatus according to claim 148, wherein the constriction device comprises a plurality of constriction elements, each of which is moveable along the urethra, ureter, renal pelvis or urine bladder to successively constrict the wall portions of the series of wall portions of the urethra, ureter, renal pelvis or urine bladder, and the stimulation device comprises stimulation elements positioned on the constriction elements for stimulating the wall portions constricted by the constriction elements to close the urinary passageway.

151. The apparatus according to claim 150, wherein the control device controls the constriction device to cyclically move the constriction elements one after the other along the wall portions of the series of wall portions of the urethra, ureter, renal pelvis or urine bladder.

152. The apparatus according to claim 151, wherein the constriction device comprises a rotor carrying the constriction elements, and the control device controls the rotor to rotate such that each constriction element cyclically constricts the wall portions of the series of wall portions of the urethra, ureter, renal pelvis or urine bladder.

153. The apparatus according to claim 152, wherein each constriction element comprises a roller for rolling on the urethra, ureter, renal pelvis or urine bladder to constrict the latter.

154. The apparatus according to claim 137, wherein the constriction device comprises a first constriction element for constricting the wall portion of the urethra, ureter, renal pelvis or urine bladder at an upstream end thereof, a second constriction element for constricting the wall portion at a downstream end thereof, and a third constriction element for constricting the wall portion between the upstream and downstream ends thereof, and the control device controls the first, second and third constriction elements to constrict and release the wall portions independently of one another.

155. The apparatus according to claim 154, wherein the control device controls the first or second constriction element to constrict the wall portion at the upstream or downstream end thereof to close the urinary passageway and controls the third constriction element to constrict the wall portion between the upstream and downstream ends thereof, whereby the urinary matter contained in the wall portion between the upstream and downstream ends thereof is moved downstream or upstream of the urinary passageway.

156. The apparatus according to claim 155, wherein the control device controls the stimulation device to stimulate the wall portion between the upstream and downstream ends thereof, when the third constriction element constricts the wall portion.

157. The apparatus according to claim 154, wherein the control device controls the first constriction element to constrict the wall portion at the upstream end thereof to restrict the flow of urine and controls the stimulation device to stimulate the constricted wall portion at the upstream end to close the urinary passageway.

158. The apparatus according to claim 157, wherein the control device controls the third constriction element to constrict the wall portion between the upstream and downstream ends thereof, whereby the urine contained in the wall portion between the upstream and downstream ends thereof is moved downstream in the urinary passageway .

159. The apparatus according to claim 158, wherein the control device controls the second constriction element to constrict the wall portion at the downstream end thereof to restrict the flow of urine and controls the stimulation device to stimulate the constricted wall portion at the downstream end to close the urinary passageway.

160. The apparatus according to claim 159, wherein the control device controls the third constriction element to constrict the wall portion between the upstream and downstream ends thereof, whereby the urine contained in the wall portion between the upstream and downstream ends thereof is moved upstream in the urinary passageway .

161. The apparatus according to claim 137, wherein the stimulation device is adapted to stimulate the wall portion with electric pulses.
162. The apparatus according to claim 1, wherein the constriction device is adjustable, and further comprising an operation device for operating the adjustable constriction device to change the constriction of the patient's wall portion of the urethra, ureter, renal pelvis or urine bladder.
163. The apparatus according to claim 162, wherein the operation device mechanically operates the constriction device.
164. The apparatus according to claim 162, wherein the operation device hydraulically operates the constriction device.
165. The apparatus according to claim 162, wherein the operation device operates the constriction device in a non-magnetic and/or non-manual manner.
166. The apparatus according to claim 162, wherein the operation device comprises an electrically powered operation device.
167. The apparatus according to claim 163, wherein the operation device comprises a motor.
168. The apparatus according to claim 163, wherein the operation device comprises a servo system.
169. The apparatus according to claim 163, wherein the constriction device comprises at least two elongated clamping elements extending along the urethra, ureter, renal pelvis or urine bladder in the direction of flow in the patient's urinary passageway on different sides of the urethra, ureter, renal pelvis or urine bladder, and the operation device operates the clamping elements to clamp the wall portion between the clamping elements to constrict the wall portion.
170. The apparatus according to claim 164, wherein the operation device comprises hydraulic means for hydraulically adjusting the constriction device and a reverse servo operatively connected to the hydraulic means.
171. The apparatus according to claim 162, wherein the constriction device comprises a non-inflatable, mechanical constriction device and the

operation device comprises hydraulic means that hydraulically adjusts the mechanical constriction device.

172. The apparatus according to claim 1, wherein the control device controls the constriction device to close the urinary passageway, either at an upstream end or a downstream end of the wall portion, and controls the constriction device to constrict the remaining part of the wall portion to move the urinary contents in the urinary passageway.

173. The apparatus according to claim 172, wherein the control device controls the stimulation device to stimulate the wall portion as the constriction device constricts the remaining part of the wall portion.

174. The apparatus according to claim 1, wherein the constriction device is adapted to constrict the wall portion to restrict but not stop the flow of urine, and the control device controls the stimulation device to stimulate the wall portion constricted by the constriction device to close the urinary passageway, either at an upstream end or a downstream end of the wall portion, and simultaneously controls the constriction device to increase the constriction of the wall portion to move the urinary contents in the urinary passageway.

175. The apparatus according to claim 1, wherein the constriction device is adapted to constrict the wall portion to restrict or vary the flow of urine, and the control device controls the stimulation device to progressively stimulate the constricted wall portion, in the downstream or upstream direction of the urinary passageway, to cause progressive contraction of the wall portion to move the urinary contents in the urinary passageway.

176. The apparatus according to claim 1, wherein the control device controls the constriction device to vary the constriction of different areas of the wall portion, such that the wall portion is progressively constricted in the downstream or upstream direction of the urinary passageway to move the urinary contents in the urinary passageway.

177. The apparatus according to claim 176, wherein the constriction device comprises at least one elongated constriction element that extends along the wall portion, and the control device controls the elongated

constriction element to progressively constrict the wall portion in the downstream or upstream direction of the urinary passageway.

178. The apparatus according to claim 176, wherein the control device controls the stimulation device to progressively stimulate the constricted wall portion to cause progressive contraction thereof in harmony with the progressive constriction of the wall portion performed by the constriction device.

179. The apparatus according to claim 178, wherein the constriction device comprises at least one elongated constriction element, and the control device controls the elongated constriction element to progressively constrict the wall portion in the downstream or upstream direction of the urinary passageway.

180. The apparatus according to claim 179, wherein the elongated constriction element comprises contact surfaces dimensioned to contact a length of the wall portion, when the constriction device constricts the wall portion, and the stimulation device comprises a plurality of stimulation elements distributed along the contact surfaces, such that the stimulation elements stimulate the different areas of the wall portion along the length of the wall portion, when the control device controls the stimulation device to stimulate the wall portion.

181. The apparatus according to claim 1, wherein the constriction device is adapted to constrict any one of a series of wall portions of the tissue wall of the urethra, ureter, renal pelvis or urine bladder to at least restrict the flow in the urinary passageway .

182. The apparatus according to claim 181, wherein the control device controls the constriction device to successively constrict the wall portions of the series of wall portions to move the urinary contents in the urinary passageway in a peristaltic manner.

183. The apparatus according to claim 181, wherein the constriction device comprises at least one constriction element moveable along the wall of the urethra, ureter, renal pelvis or urine bladder to successively constrict the wall portions of the series of wall portions, and the control device controls the

constriction device to cyclically move the constriction element along the wall portions of the series of wall portions.

184. The apparatus according to claim 182, wherein the constriction device comprises a plurality of constriction elements, each of which is moveable along the wall of the urethra, ureter, renal pelvis or urine bladder to successively constrict the wall portions of the series of wall portions, wherein the control device controls the constriction device to cyclically move the constriction elements one after the other along the wall portions of the series of wall portions.

185. The apparatus according to claim 184, wherein the constriction device includes a rotor carrying the constriction elements, and the control device controls the rotor to rotate, such that each constriction element cyclically constricts the wall portions of the series of wall portions.

186. The apparatus according to claim 185, wherein each constriction element comprises a roller for rolling on the wall of the urethra, ureter, renal pelvis or urine bladder to constrict the latter.

187. The apparatus according to claim 182, wherein the stimulation device stimulates the wall portion of the series of wall portions which is constricted by the constriction device, to close the urinary passageway.

188. The apparatus according to claim 183, wherein the stimulation device comprises at least one stimulation element positioned on the constriction element for stimulating the wall portion constricted by the constriction element to close the urinary passageway.

189. The apparatus according to claim 184, wherein the stimulation device comprises stimulation elements positioned on the constriction elements for stimulating the wall portions constricted by the constriction elements to close the urinary passageway.

190. The apparatus according to claim 1, wherein the constriction device comprises a first constriction element for constricting the wall portion at an upstream end thereof, a second constriction element for constricting the wall portion at a downstream end thereof, and a third constriction element for

constricting the wall portion between the upstream and downstream ends thereof.

191. The apparatus according to claim 190, wherein the control device controls the first, second and third constriction elements to constrict and release the wall portion independently of one another.

192. The apparatus according to claim 191, wherein the control device controls the first or second constriction element to constrict the wall portion at the upstream or downstream end thereof to close the urinary passageway, and controls the third constriction element to constrict the wall portion between the upstream and downstream ends thereof, whereby the urine contained in the wall portion between the upstream and downstream ends thereof is moved downstream or upstream of the urinary passageway.

193. The apparatus according to claim 192, wherein the control device controls the stimulation device to stimulate the wall portion between the upstream and downstream ends thereof, when the third constriction element constricts the wall portion.

194. The apparatus according to claim 191, wherein the control device controls the first constriction element to constrict the wall portion at the upstream end thereof to restrict the flow of urine and controls the stimulation device to stimulate the constricted wall portion at the upstream end to close the urinary passageway .

195. The apparatus according to claim 194, wherein the control device controls the third constriction element to constrict the wall portion between the upstream and downstream ends thereof to move the urine contained in the wall portion between the upstream and downstream ends thereof downstream in the urinary passageway.

196. The apparatus according to claim 195, wherein the control device controls the stimulation device to simultaneously stimulate the wall portion as the latter is constricted by the third constriction element.

197. The apparatus according to claim 191, wherein the control device controls the second constriction element to constrict the wall portion at the downstream end thereof to restrict the flow in the urinary passageway



and controls the stimulation device to stimulate the constricted wall portion at the downstream end to close the urinary passageway .

198. The apparatus according to claim 197, wherein the control device controls the third constriction element to constrict the wall portion between the upstream and downstream ends thereof to move the urine contained in the wall portion between the upstream and downstream ends thereof upstream of the urinary passageway.

199. The apparatus according to claim 198, wherein the control device controls the stimulation device to simultaneously stimulate the wall portion as the latter is constricted by the third constriction element.

200. The apparatus according to claim 137, wherein the constriction device comprises a plurality of separate constriction elements adapted to constrict any wall portions of a series of wall portions, respectively, of the urethra, ureter, renal pelvis or urine bladder.

201. The apparatus according to claim 200 wherein the control device controls the constriction device to activate the constriction elements in random or in accordance with a predetermined sequence.

202. The apparatus according to claim 200, wherein the control device controls the constriction device to activate the constriction elements one after the other, so that the wall portions of the series of wall portions are successively constricted along the urethra, ureter, renal pelvis or urine bladder to move the urinary contents in the urinary passageway.

203. The apparatus according to claim 200, wherein the stimulation device comprises stimulation elements positioned on the constriction elements.

204. The apparatus according to claim 203, wherein the control device controls the stimulation device to activate the stimulation elements to stimulate any wall portions of the series of wall portions constricted by the constriction elements.

205. The apparatus according to claim 204, wherein the control device controls the constriction device to activate the constriction elements to

constrict the wall portions of the series of wall portions without completely closing the urinary passageway, and controls the stimulation device to activate the stimulation elements to stimulate the constricted wall portions one after the other, so that the wall portions of the series of wall portions are successively contracted along the urethra, ureter, renal pelvis or urine bladder to move the urinary contents in the urinary passageway.

206. The apparatus according to claim 204, wherein the control device controls the constriction device to activate the constriction elements to constrict all of the wall portions of the series of wall portions, and controls the stimulation device to activate the stimulation elements to stimulate any constricted wall portions in random or in accordance with a predetermined sequence to close the urethra, ureter, renal pelvis or urine bladder's urinary passageway.

207. A method of using an apparatus as recited in claim 1 to treat a patient suffering from urinary dysfunction, the method comprising: providing a wireless remote control adapted to control the constriction device and/or stimulation device from outside the patient's body, and operating the wireless remote control by the patient, when the patient wants to influence the flow of urine.

208. An apparatus for controlling the flow of urine in an urinary passageway formed by the tissue wall of a patient's urethra, ureter, renal pelvis or urine bladder, the apparatus comprising:

an implantable constriction device for gently constricting at least one wall portion of the tissue wall of the urethra, ureter, renal pelvis or urine bladder to influence the flow of urine ,

a stimulation device for stimulating the wall portion, as the constriction device constricts the wall portion, to cause contraction of the wall portion to further influence the flow of urine, wherein the constriction and stimulation devices form an operable constriction/stimulation unit,

a source of energy, and

a control device operable from outside the patient's body to control the source of energy to release energy for use in connection with the operation of the constriction/stimulation unit.

209. The apparatus according to claim 208, wherein the source of energy is implantable in the patient's body.

210. The apparatus according to claim 209, wherein the source of energy comprises a battery.

211. The apparatus according to claim 208, wherein the source of energy is external to the patient's body and the control device controls the external source of energy to release wireless energy, further comprising an energy-transmission device for transmitting the released wireless energy from outside the patient's body to inside the patient's body.

212. The apparatus according to claim 211, wherein the energy-transmission device is adapted to transmit the wireless energy in pulses or digital pulses, or a combination of pulses and digital pulses.

213. The apparatus according to claim 211, wherein the wireless energy comprises electromagnetic energy.

214. The apparatus according to claim 211, wherein the wireless energy comprises an electric, an electromagnetic or a magnetic field, or a combination thereof, or electromagnetic waves.

215. The apparatus according to claim 211, wherein the energy-transmission device transmits wireless energy for direct use in connection with the operation of the constriction/stimulation unit, as the wireless energy is being transmitted.

216. The apparatus according to claim 215, further comprising an implantable electric motor or pump for operating the constriction device, wherein the motor or pump is directly powered by wireless energy in the form of a magnetic or an electromagnetic field.

217. The apparatus according to claim 216, wherein the motor or pump comprises coils, and the magnetic or electromagnetic field influences the coils to generate a current for driving the motor or pump.

218. The apparatus according to claim 216, wherein the motor or pump comprises materials influenced by magnetic fields, and the magnetic or electromagnetic field influences the materials to create kinetic energy for driving the motor or pump.

219. The apparatus according to claim 216, wherein the motor or pump comprises permanent magnets, and the magnetic or electromagnetic field influences the magnets to create kinetic energy for driving the motor or pump.

220. The apparatus according to claim 211, wherein the energy-transmission device transmits energy of a first form and the constriction/stimulation unit is operable in response to energy of a second form, and further comprising an energy-transforming device implantable in the patient for transforming the energy of the first form wirelessly transmitted by the energy-transmission device into the energy of the second form.

221. The apparatus according to claim 220, wherein the energy of the second form is different from the energy of the first form.

222. The apparatus according to claim 220, wherein the energy-transforming device comprises at least one element having a positive region and a negative region, when exposed to the energy of the first form transmitted by the energy-transmission device the element is capable of creating an energy field between the positive and negative regions, and the energy field produces the energy of the second form.

223. The apparatus according to claim 222, wherein the element comprises an electrical junction element, and the electrical junction element is capable of inducing an electric field between the positive and negative regions when exposed to the energy of the first form transmitted by the energy-transmission device, whereby the energy of the second form comprises electric energy.

224. The apparatus according to claim 222, wherein the energy-transforming device comprises at least one semiconductor.

225. The apparatus according to claim 224, wherein the semiconductor comprises at least one element having a positive region and a

negative region, when exposed to the energy of the first form transmitted by the energy-transmission device, the element is capable of creating an energy field between the positive and negative regions, and the energy field produces the energy of the second form.

226. The apparatus according to claim 221, wherein the energy-transforming device transforms the energy of the first form directly or indirectly into the energy of the second form.

227. The apparatus according to claim 226, further comprising an implantable motor or pump for operating the constriction device, wherein the motor or pump is powered by the energy of the second form.

228. The apparatus according to claim 227, wherein the constriction device is operable to perform at least one reversible function and the motor is capable of reversing the function.

229. The apparatus according to claim 227, wherein the control device shifts polarity of the energy of the second form to reverse the motor.

230. The apparatus according to claim 227, wherein the energy-transforming device directly powers the motor or pump with the transformed energy, as the energy of the second form is being transformed from the energy of the first form.

231. The apparatus according to claim 226, wherein the wireless energy of the first form comprises sound waves and the energy of the second form comprises electric energy.

232. The apparatus according to claim 231, wherein the energy-transforming device comprises a piezo-electric element for transforming sound waves into electric energy.

233. The apparatus according to claim 220, further comprising an internal source of energy implantable in the patient for supplying energy for the operation of the constriction/stimulation unit.

234. The apparatus according to claim 233, wherein the internal source of energy comprises a battery.

235. The apparatus according to claim 233, wherein the internal source of energy stores the energy of the second form supplied by the energy-transforming device.

236. The apparatus according to claim 235, wherein the internal source of energy comprises an accumulator.

237. The apparatus according to claim 236, wherein the accumulator comprises at least one capacitor or at least one rechargeable battery, or a combination of at least one capacitor and at least one rechargeable battery.

238. The apparatus according to claim 233, further comprising an implantable switch operable to switch from an off mode, in which the internal source of energy is not in use, to an on mode, in which the internal source of energy supplies energy for the operation of the constriction/stimulation unit.

239. The apparatus according to claim 238, wherein the switch is operable by the energy of the first form transmitted by the energy-transmission device.

240. The apparatus according to claim 238, wherein the switch is operable by the energy of the second form supplied by the energy-transforming device.

241. The apparatus according to claim 220, further comprising an implantable stabiliser for stabilising the energy of the second form.

242. The apparatus according to claim 241, wherein the energy of the second form comprises electric current and the stabiliser comprises at least one capacitor.

243. The apparatus according to claim 220, wherein the energy-transforming device directly operates the constriction/stimulation unit with the energy of the second form in a non-magnetic, non-thermal or non-mechanical manner.

244. The apparatus according to claim 211, wherein the energy-transmission device transmits energy by at least one wireless signal.

245. The apparatus according to claim 244, wherein the signal comprises a wave signal.

246. The apparatus according to claim 245, wherein the wave signal comprises an electromagnetic wave signal including one of an infrared light signal, a visible light signal, an ultra violet light signal, a laser signal, a micro wave signal, a radio wave signal, an x-ray radiation signal, and a gamma radiation signal.

247. The apparatus according to claim 245, wherein the wave signal comprises a sound or ultrasound wave signal.

248. The apparatus according to claim 244, wherein the signal comprises a digital or analogue signal, or a combination of a digital and analogue signal.

249. The apparatus according to claim 220, wherein the energy-transforming device transforms the energy of the first form into a direct current or pulsating direct current, or a combination of a direct current and pulsating direct current.

250. The apparatus according to claim 221, wherein the energy-transforming device transforms the energy of the first form into an alternating current or a combination of a direct and alternating current.

251. The apparatus according to claim 220, wherein one of the energy of the first form and the energy of the second form comprises magnetic energy, kinetic energy, sound energy, chemical energy, radiant energy, electromagnetic energy, photo energy, nuclear energy or thermal energy.

252. The apparatus according to claim 220, wherein one of the energy of the first form and the energy of the second form is non-magnetic, non-kinetic, non-chemical, non-sonic, non-nuclear or non-thermal.

253. The apparatus according to claim 208, further comprising implantable electrical components including at least one voltage level guard.

254. The apparatus according to claim 208, further comprising implantable electrical components including at least one constant current guard.

255. The apparatus according to claim 220, wherein the energy-transmission device functions different from the energy-transforming device.
256. The apparatus according to claim 220, wherein the energy-transmission device functions similar to the energy-transforming device.
257. The apparatus according to claim 220, wherein the energy-transforming device is designed to be implanted subcutaneously or in the abdomen, thorax or cephalic region of the patient.
258. The apparatus according to claim 220, wherein the energy-transforming device is designed to be implanted in an orifice of the patient's body and under the mucosa or intramuscularly outside the mucosa of the orifice.
259. The apparatus according to claim 208, wherein the control device controls the constriction/stimulation unit.
260. The apparatus according to claim 259, wherein the control device comprises a microprocessor.
261. The apparatus according to claim 208, wherein the control device is operable by the patient.
262. The apparatus according to claim 208, wherein the control device comprises a manually or magnetically operable switch for switching on and off the constriction/stimulation unit, the switch being adapted for subcutaneous implantation in the patient.
263. The apparatus according to claim 261, wherein the control device comprises a hand-held wireless remote control operable by the patient to control the constriction/stimulation unit to adjust the stimulation intensity and/or adjust the constriction of the wall portion.
264. The apparatus according to claim 208, wherein the control device comprises a remote control for controlling the constriction/stimulation unit from outside the patient's body.
265. The apparatus according to claim 264, wherein the remote control comprises a wireless remote control.



266. The apparatus according to claim 265, wherein the wireless remote control comprises at least one external signal transmitter or transceiver and at least one internal signal receiver or transceiver implantable in the patient.

267. The apparatus according to claim 265, wherein the wireless remote control is adapted to transmit at least one wireless control signal for controlling the constriction/stimulation unit.

268. The apparatus according to claim 267, wherein the control signal comprises a frequency, amplitude, phase modulated signal or a combination thereof.

269. The apparatus according to claim 267, wherein the control signal comprises an analogue or a digital signal, or a combination of an analogue and digital signal.

270. The apparatus according to claim 269, wherein the remote control transmits a carrier signal for carrying the control signal.

271. The apparatus according to claim 270, wherein the carrier signal comprises digital, analogue or a combination of digital and analogue signals.

272. The apparatus according to claim 271, wherein the signals comprise wave signals.

273. The apparatus according to claim 267, wherein the control signal comprises a wave signal comprising one of a sound wave signal, an ultrasound wave signal, an electromagnetic wave signal, an infrared light signal, a visible light signal, an ultra violet light signal, a laser light signal, a micro wave signal, a radio wave signal, an x-ray radiation signal and a gamma radiation signal.

274. The apparatus according to claim 267, wherein the control signal comprises an electric or magnetic field, or a combined electric and magnetic field.

275. The apparatus according to claim 269, wherein the remote control transmits an electromagnetic carrier wave signal for carrying the digital or analogue control signal.

276. The apparatus according to claim 208, further comprising an external data communicator and an implantable internal data communicator communicating with the external data communicator, wherein the internal communicator feeds data related to the constriction/stimulation unit back to the external data communicator or the external data communicator feeds data to the internal data communicator.

277. The apparatus according to claim 208, further comprising at least one implantable sensor, wherein the control device is adapted to control the constriction/stimulation unit in response to signals from the sensor.

278. The apparatus according to claim 277, wherein the sensor is adapted to directly or indirectly sense at least one physical parameter of the patient.

279. The apparatus according to claim 277, wherein the sensor is adapted to directly or indirectly sense at least one functional parameter of a medical implant.

280. The apparatus according to claim 278, wherein the sensor comprises a pressure sensor for directly or indirectly sensing the pressure against the constriction device.

281. The apparatus according to claim 280, wherein the control device is adapted to control the constriction/stimulation unit to change the constriction of the patient's wall portion in response to the pressure sensor sensing a predetermined value.

282. The apparatus according to claim 277, wherein the control device comprises an internal control unit implanted in the patient and directly controlling the constriction/stimulation unit in response to signals from the sensor.

283. The apparatus according to claim 277, wherein the control device comprises an external control unit outside the patient's body controlling the constriction/stimulation unit in response to signals from the sensor.

284. The apparatus according to claim 277, wherein the control device comprises an implantable internal control unit that directly controls the constriction/stimulation unit in response to signals from the sensor.

285. The apparatus according to claim 277, wherein the control device comprises an external control unit outside the patient's body for controlling the constriction/stimulation unit in response to signals from the sensor.

286. The apparatus according to claim 278, wherein the control device is adapted to produce an indication in response to the sensor sensing the physical parameter.

287. The apparatus according to claim 286, wherein the indication comprises a sound signal or displayed information.

288. The apparatus according to claim 208, further comprising an implantable operation device adapted to operate the constriction/stimulation unit.

289. The apparatus according to claim 288, further comprising a magnet for activating the operation device.

290. The apparatus according to claim 289, wherein the magnet is adapted to activate the operation device from outside the patient's body.

291. The apparatus according to claim 289, wherein the operation device comprises a motor.

292. The apparatus according to claim 291, wherein the motor is powered by energy released from the source of energy.

293. The apparatus according to claim 291, further comprising an implantable gearbox, wherein the motor is operatively connected to the constriction device of the constriction/stimulation unit via the gearbox.

294. The apparatus according to claim 208, wherein the constriction device is operable to perform a reversible function.

295. The apparatus according to claim 294, further comprising a reversing device implantable in the patient for reversing the function performed by the constriction device.

296. The apparatus according to claim 295, wherein the control device controls the reversing device to reverse the function performed by the constriction device.

297. The apparatus according to claim 295, wherein the reversing device comprises hydraulic means including a valve for shifting the flow direction of a liquid flow in the hydraulic means.

298. The apparatus according to claim 295, wherein the reversing device comprises a mechanical reversing device.

299. The apparatus according to claim 295, wherein the mechanical reversing device comprises a gearbox.

300. The apparatus according to claim 295, wherein the reversing device comprises a switch.

301. The apparatus according to claim 233, further comprising a sensor or measuring device sensing or measuring a functional parameter correlated to the transfer of energy for charging the internal source of energy, and a feedback device for sending feedback information from inside the patient's body to the outside thereof, the feedback information being related to the functional parameter sensed by the sensor or measured by the measuring device.

302. The apparatus according to claim 208, further comprising a feedback device for sending feedback information from inside the patient's body to the outside thereof, the feedback information being related to at least one of a physical parameter of the patient and a functional parameter related to the constriction/stimulation unit.

303. The apparatus according to claim 209, further comprising a sensor and/or a measuring device, wherein the control device comprises an implantable internal control unit for controlling the constriction/stimulation unit in response to information being related to at least one of a physical

parameter of the patient sensed by the sensor or measured by the measuring device and a functional parameter related to the constriction/stimulation unit sensed by the sensor or measured by the measuring device.

304. The apparatus according to claim 303, wherein the physical parameter is a pressure or a motility movement.

305. The apparatus according to claim 211, further comprising an implantable internal energy receiver for receiving the transmitted wireless energy, the internal energy receiver being connected to implantable energy consuming components of the apparatus for directly or indirectly supplying received energy thereto, the apparatus further comprising a determination device adapted to determine an energy balance between the energy received by the internal energy receiver and the energy used for the implantable energy consuming components of the apparatus, wherein the control device controls the transmission of wireless energy from the external energy-transmission device, based on the energy balance determined by the determination device.

306. The apparatus according to claim 305, wherein the determination device is adapted to detect a change in the energy balance, and the control device controls the transmission of wireless energy based on the detected energy balance change.

307. The apparatus according to claim 305, wherein the determination device is adapted to detect a difference between energy received by the internal energy receiver and energy used for the implantable energy consuming components of the apparatus, and the control device controls the transmission of wireless energy based on the detected energy difference.

308. The apparatus according to claim 211, wherein the energy-transmission device comprises a coil placed externally to the human body, further comprising an implantable energy receiver to be placed internally in the human body and an electric circuit connected to power the external coil with electrical pulses to transmit the wireless energy, the electrical pulses having leading and trailing edges, the electric circuit adapted to vary first time

intervals between successive leading and trailing edges and/or second time intervals between successive trailing and leading edges of the electrical pulses to vary the power of the transmitted wireless energy, the energy receiver receiving the transmitted wireless energy having a varied power.

309. The apparatus according to claim 308, wherein the electric circuit is adapted to deliver the electrical pulses to remain unchanged except varying the first and/or second time intervals.

310. The apparatus according to claim 308, wherein the electric circuit has a time constant and is adapted to vary the first and second time intervals only in the range of the first time constant, so that when the lengths of the first and/or second time intervals are varied, the transmitted power over the coil is varied.

311. The apparatus according to claim 302, further comprising an implantable internal energy receiver for receiving wireless energy, the energy receiver having an internal first coil and a first electronic circuit connected to the first coil, and an external energy transmitter for transmitting wireless energy, the energy transmitter having an external second coil and a second electronic circuit connected to the second coil, wherein the external second coil of the energy transmitter transmits wireless energy which is received by the first coil of the energy receiver, the system further comprising a power switch for switching the connection of the internal first coil to the first electronic circuit on and off, such that feedback information related to the charging of the first coil is received by the external energy transmitter in the form of an impedance variation in the load of the external second coil, when the power switch switches the connection of the internal first coil to the first electronic circuit on and off.

312. The apparatus according to claim 302, further comprising an implantable internal energy receiver for receiving wireless energy, the energy receiver having an internal first coil and a first electronic circuit connected to the first coil, and an external energy transmitter for transmitting wireless energy, the energy transmitter having an external second coil and a second electronic circuit connected to the second coil, wherein the external second

coil of the energy transmitter transmits wireless energy which is received by the first coil of the energy receiver, the system further comprising a feedback device for communicating out the amount of energy received in the first coil as a feedback information, and wherein the second electronic circuit includes a determination device for receiving the feedback information and for comparing the amount of transferred energy by the second coil with the feedback information related to the amount of energy received in the first coil to obtain the coupling factors between the first and second coils.

313. The apparatus according to claim 312, wherein the energy transmitter regulates the transmitted energy in response to the obtained coupling factor.

314. The apparatus according to claim 312, wherein external second coil is adapted to be moved in relation to the internal first coil to establish the optimal placement of the second coil, in which the coupling factor is maximized.

315. The apparatus according to claim 314, wherein the external second coil is adapted to calibrate the amount of transferred energy to achieve the feedback information in the determination device, before the coupling factor is maximized.

316. An apparatus for controlling the flow of urine in the urethra, ureter, renal pelvis or urine bladder of a patient, the apparatus comprising an implantable stimulation device for stimulating at least one portion of the tissue wall of the patient's urethra, ureter, renal pelvis or urine bladder, and a control device for controlling the stimulation device to stimulate the wall portion to cause contraction of the wall portion to influence the flow of urine in the urethra, ureter, renal pelvis or urine bladder.

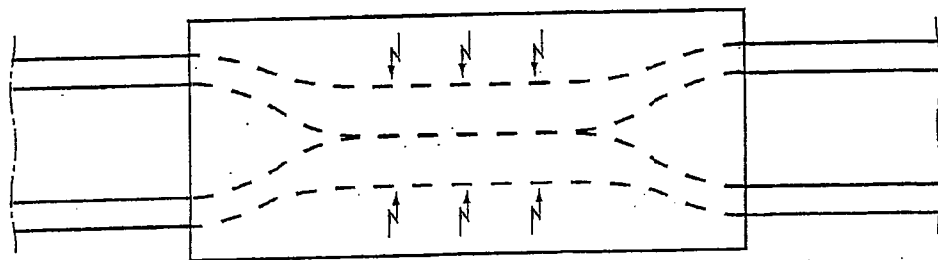
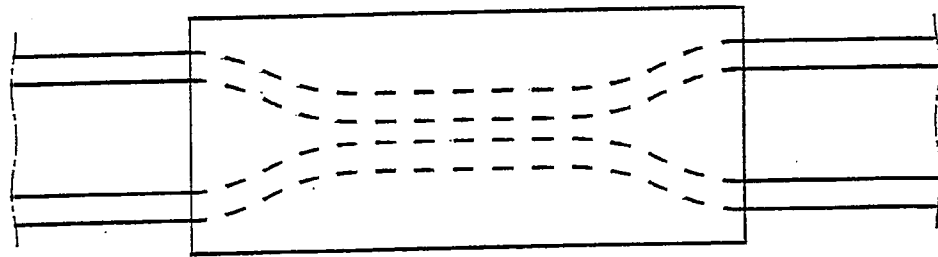
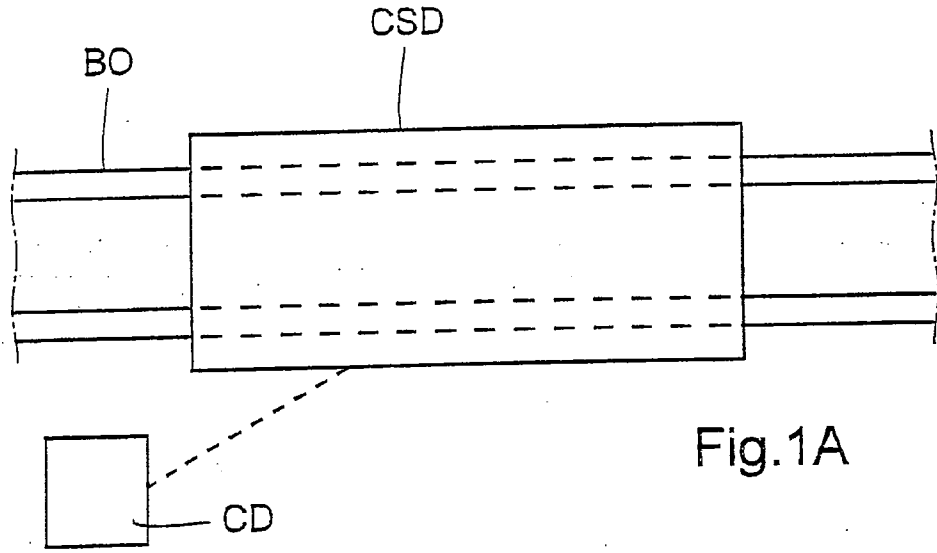



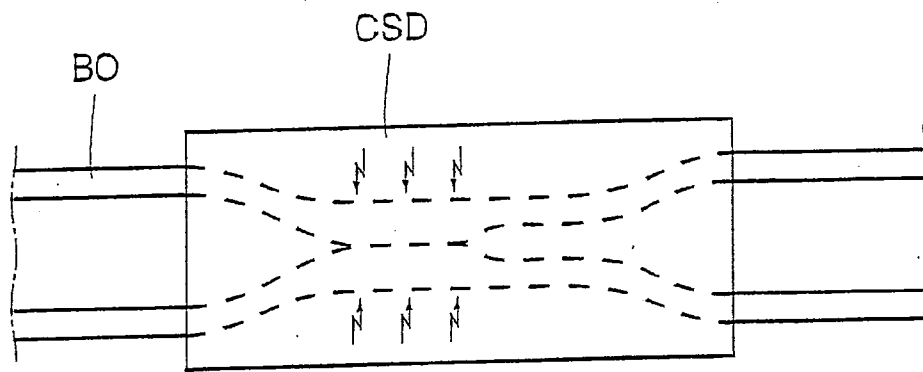

Fig.1D

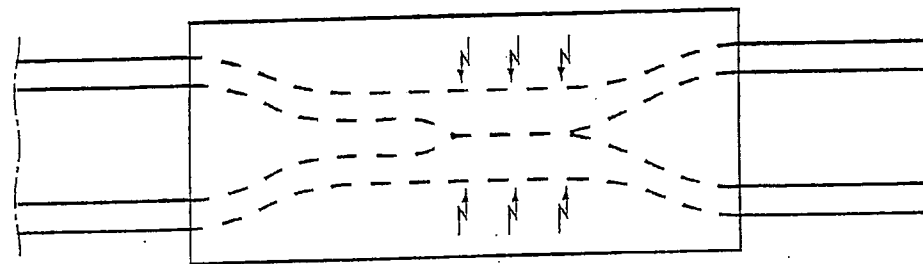
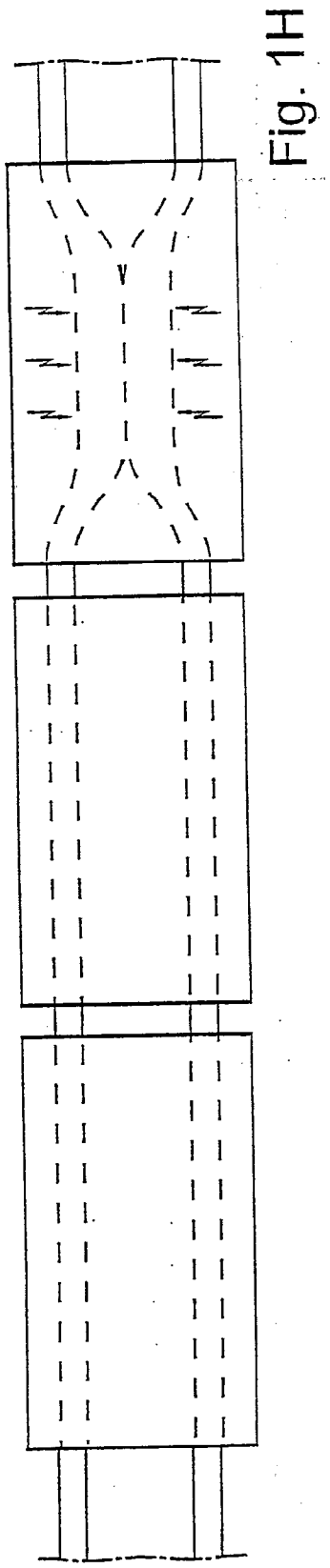
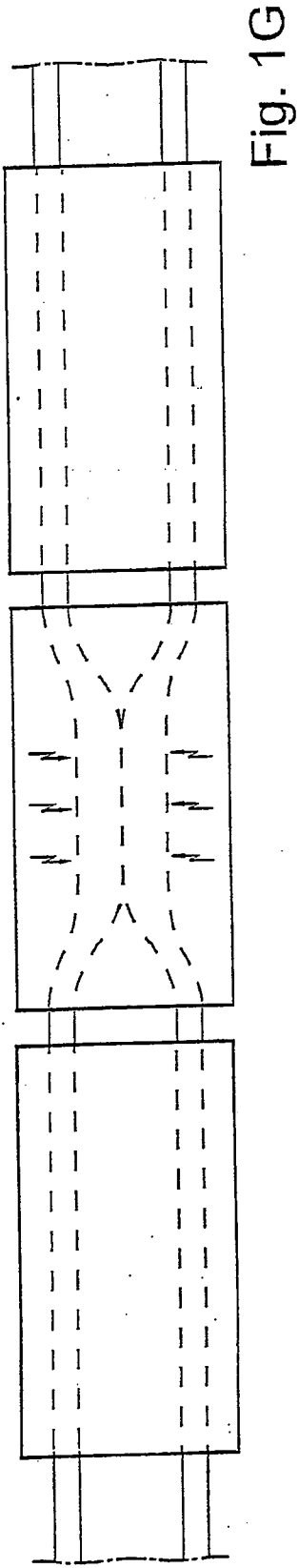
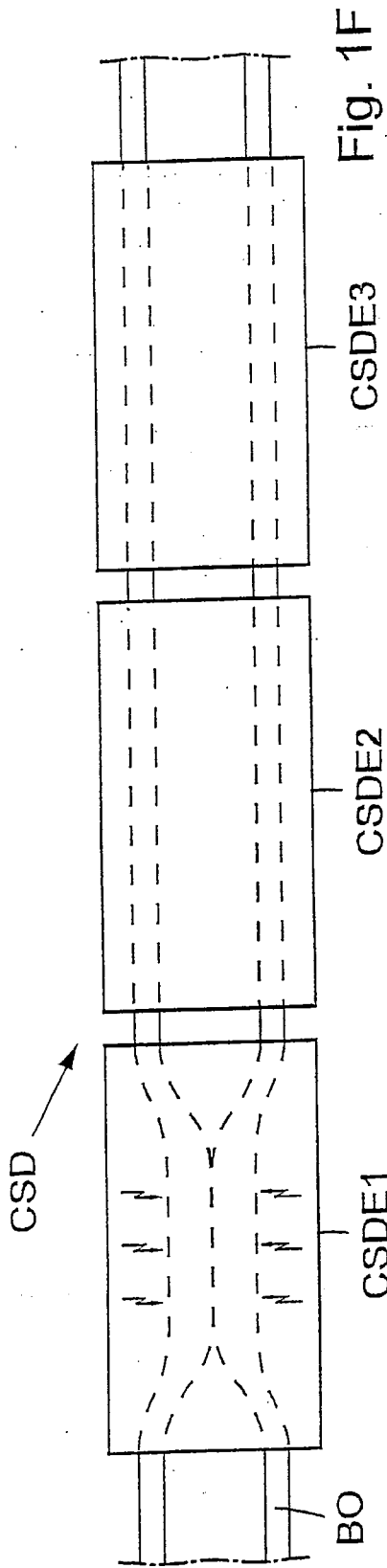

Fig.1E



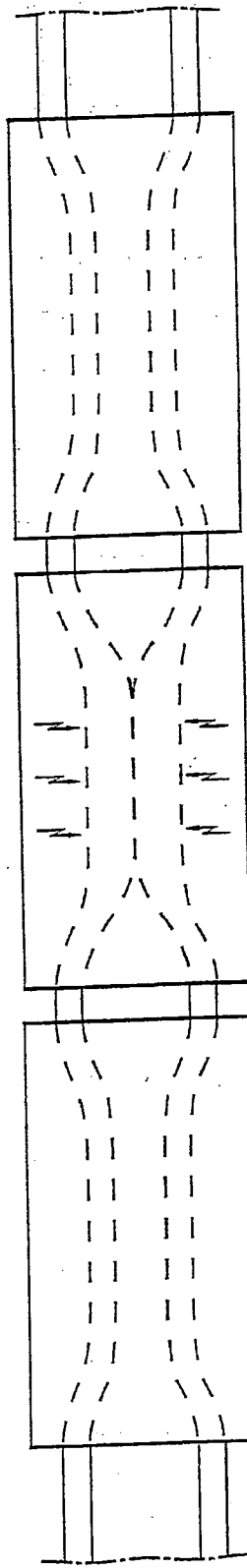
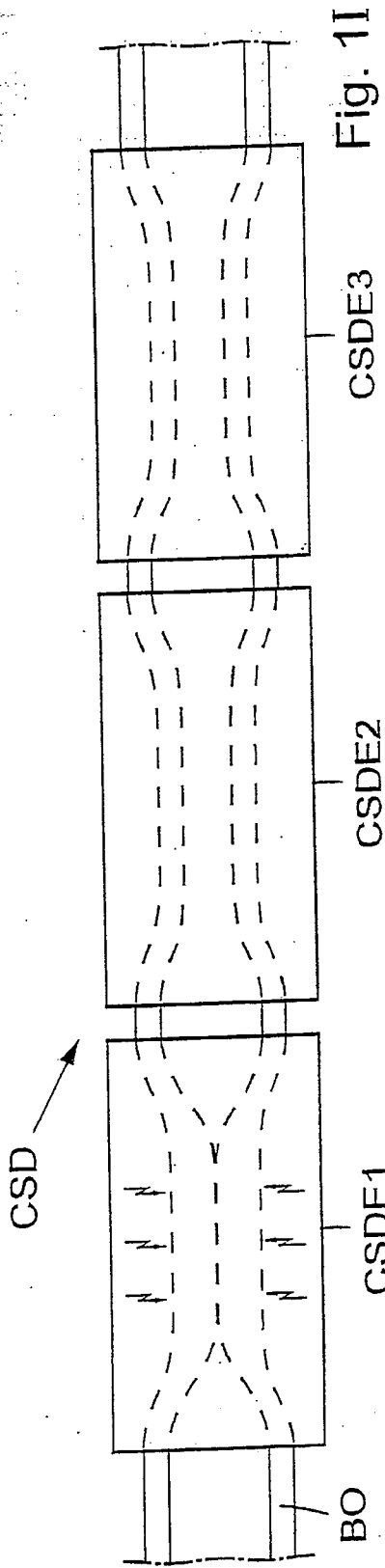

Fig. 1K

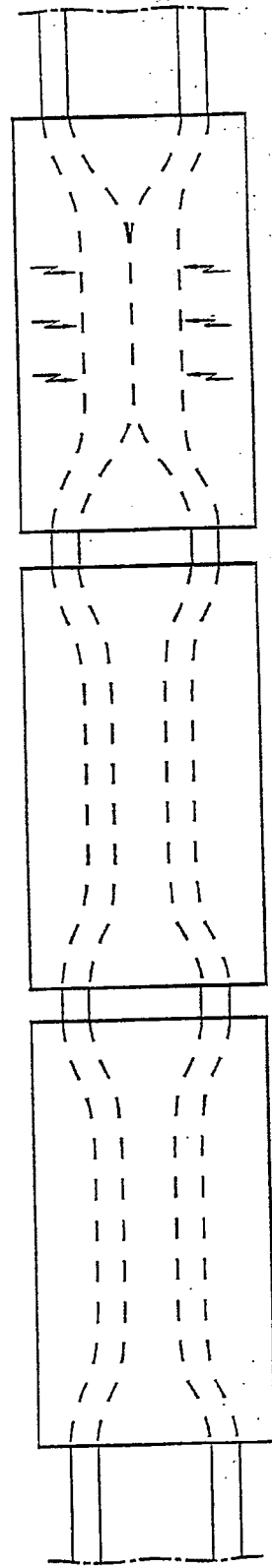
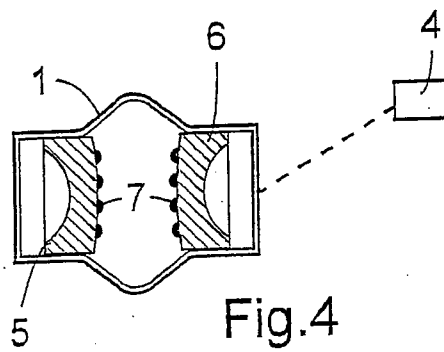
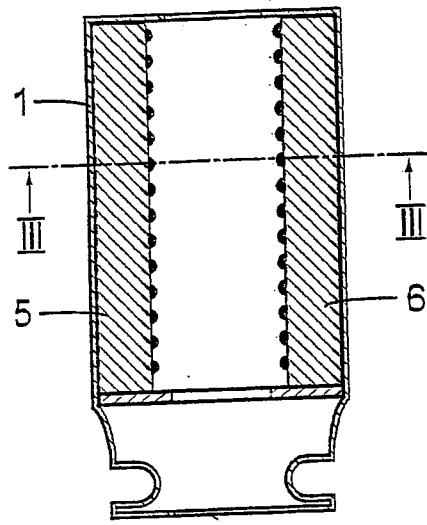
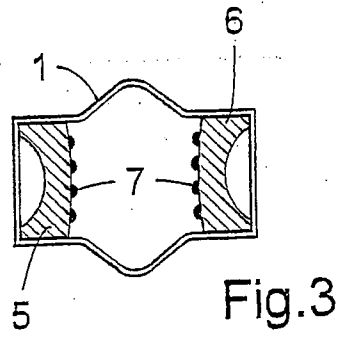

Fig. 1L



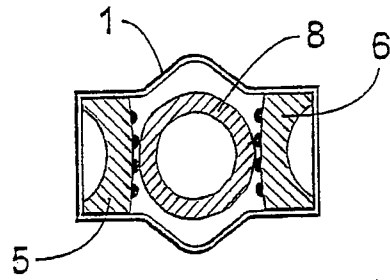

Fig. 5A

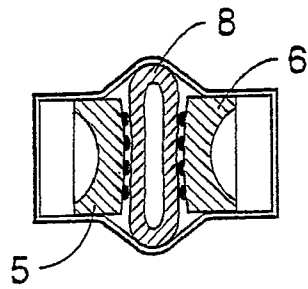

Fig. 5B

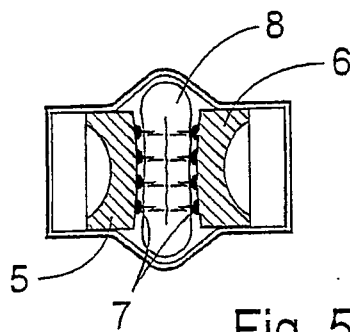

Fig. 5C

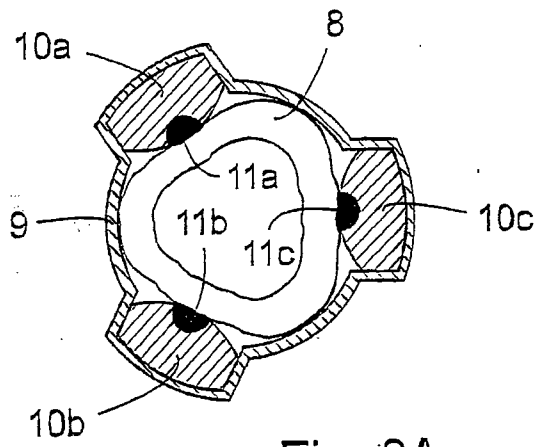

Fig. 6A

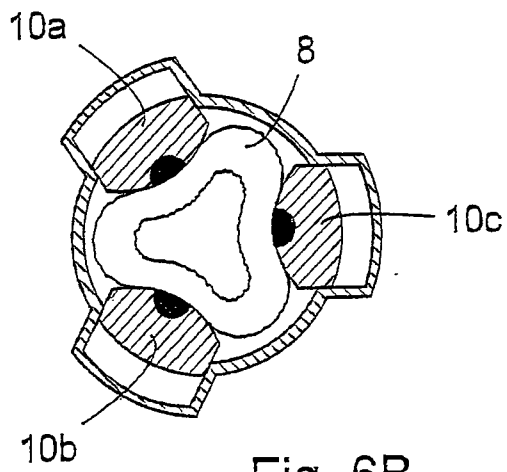

Fig. 6B

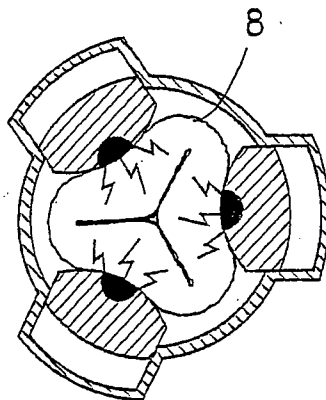

Fig. 6C

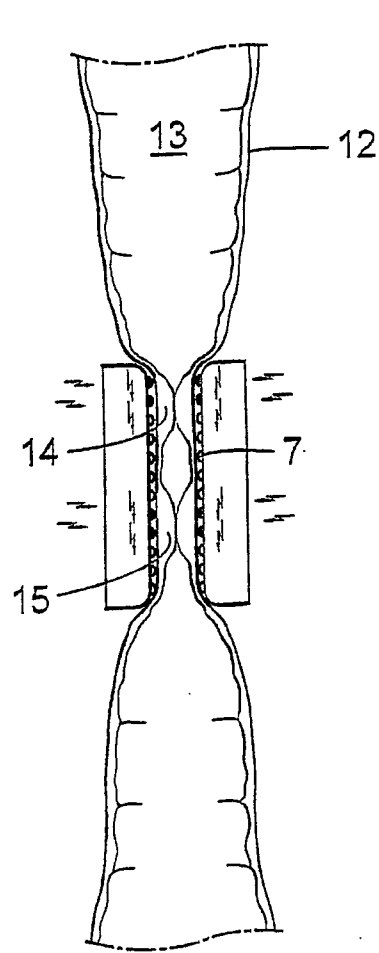

Fig. 7A

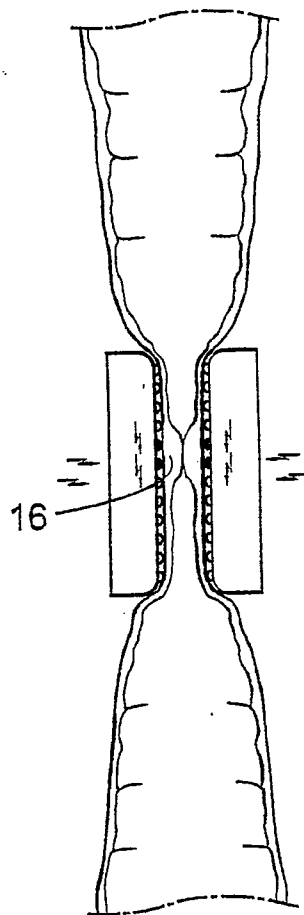

Fig. 7B

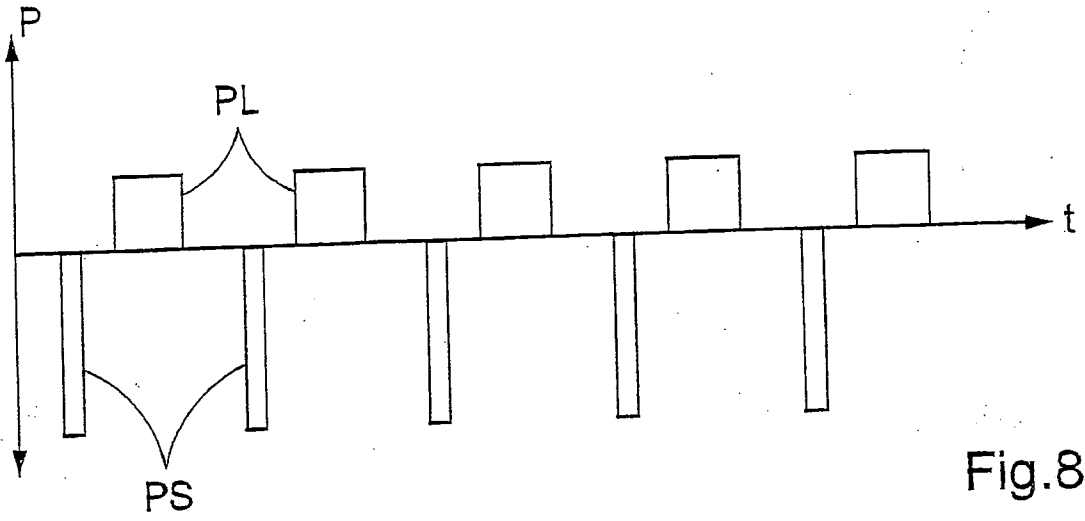

Fig.8A

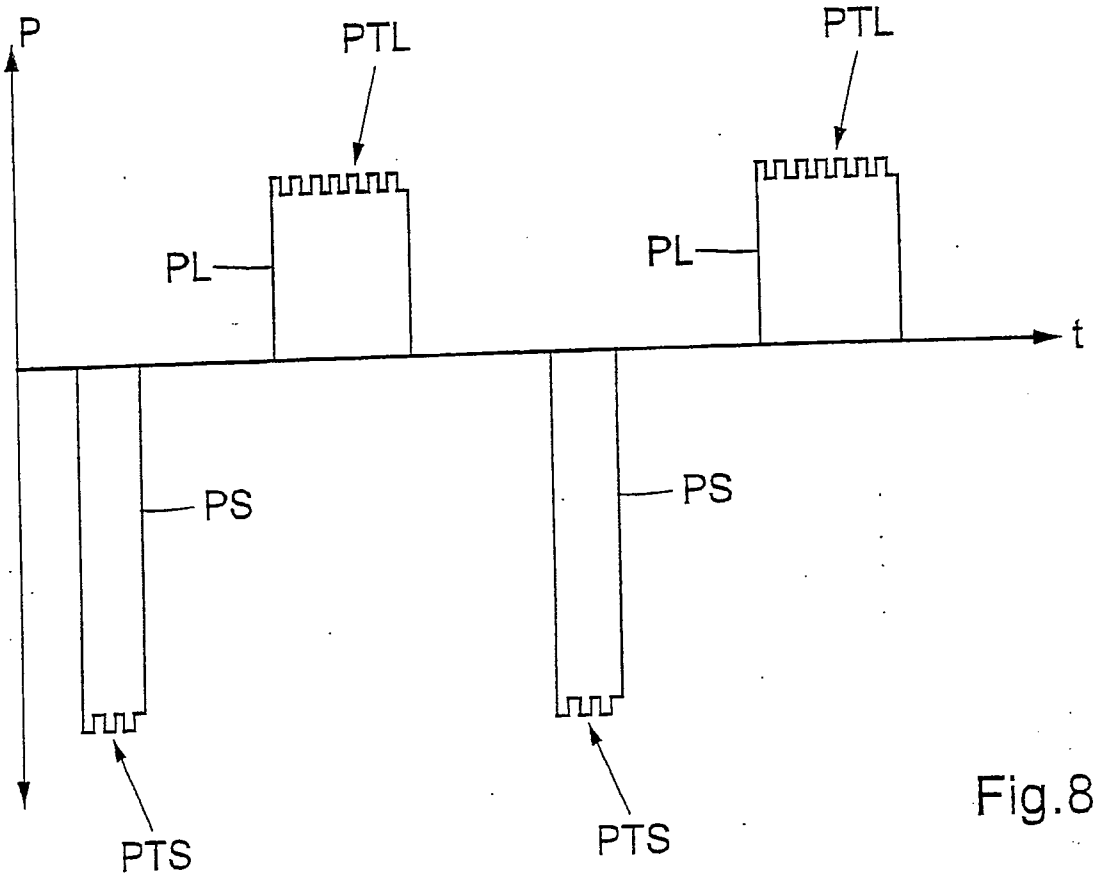

Fig.8E



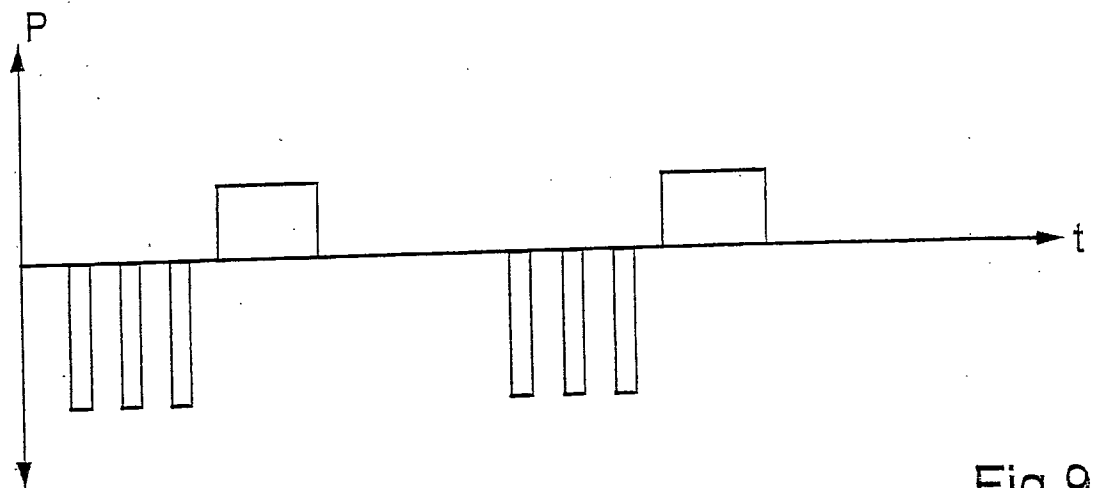

Fig.9A

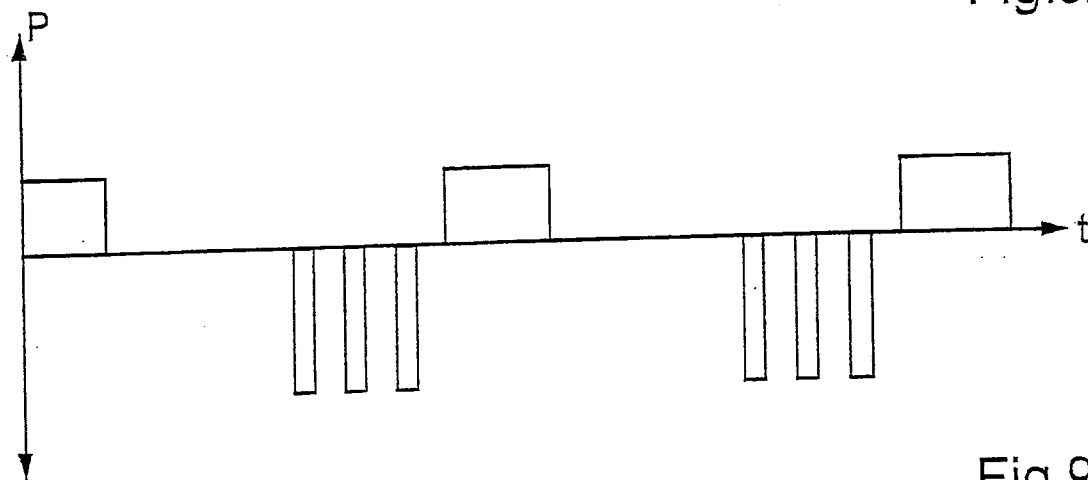

Fig.9B

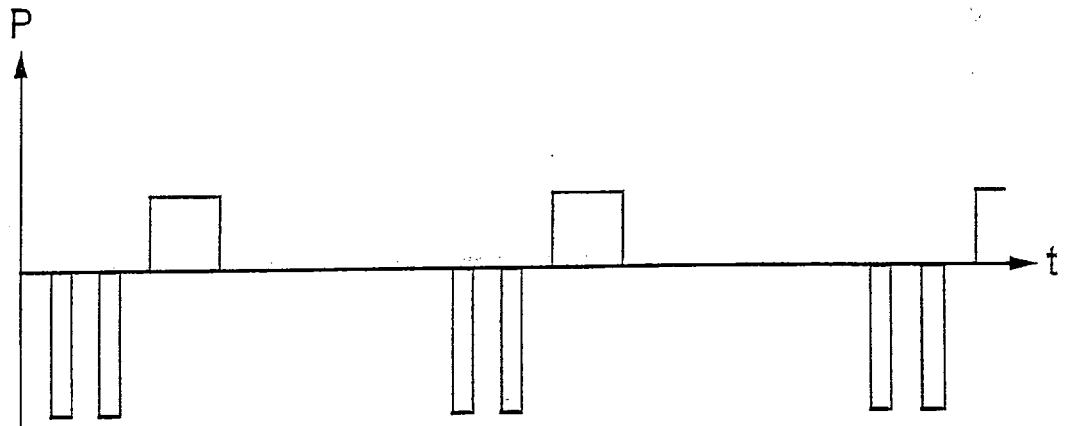

Fig.10A

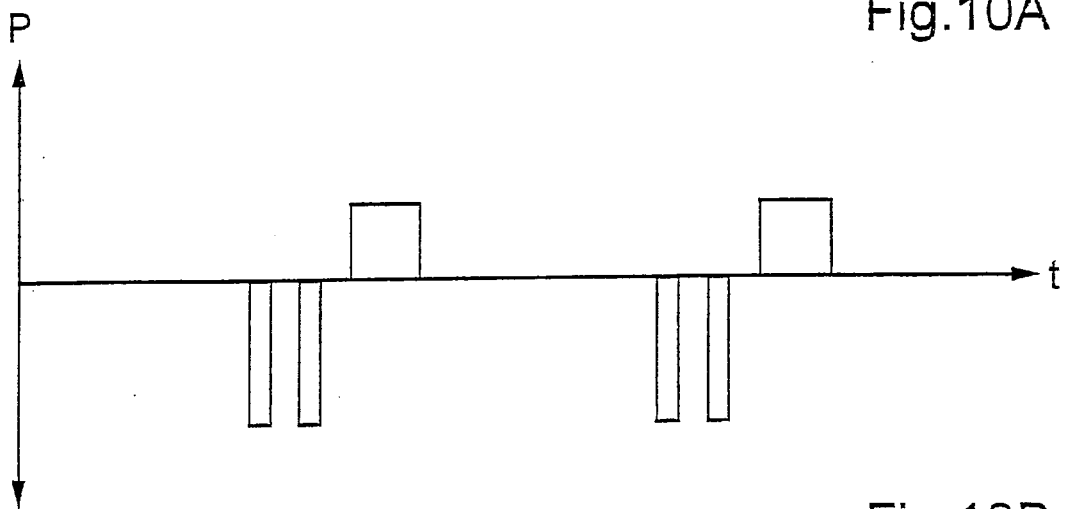

Fig.10B

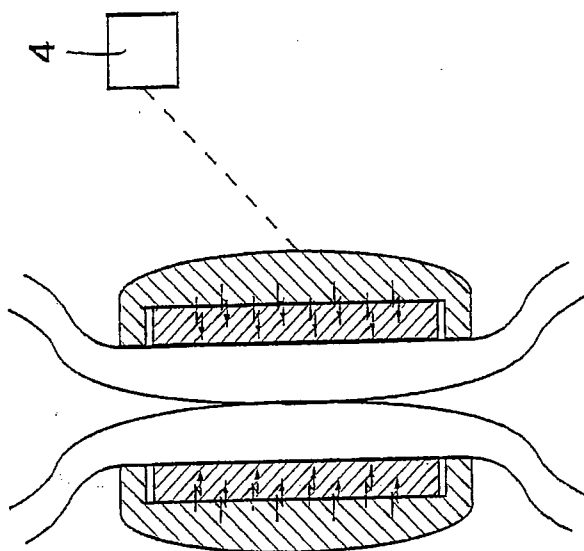

Fig. 11B

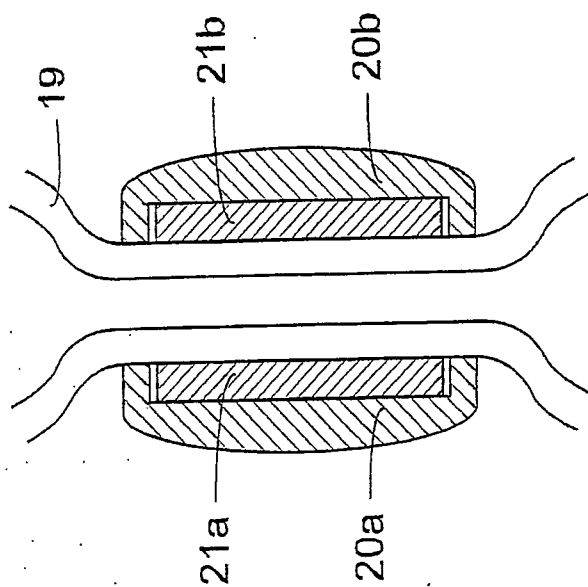
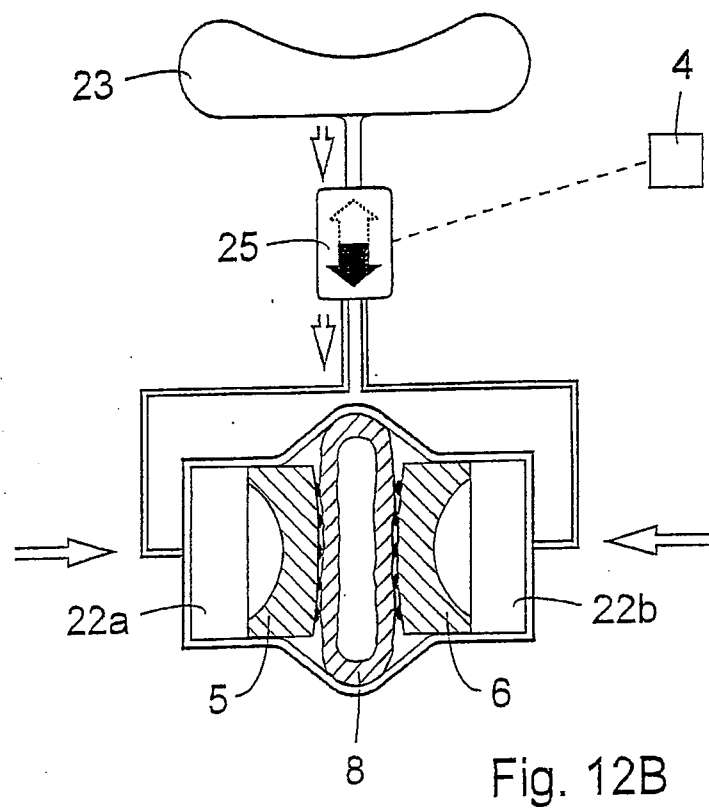
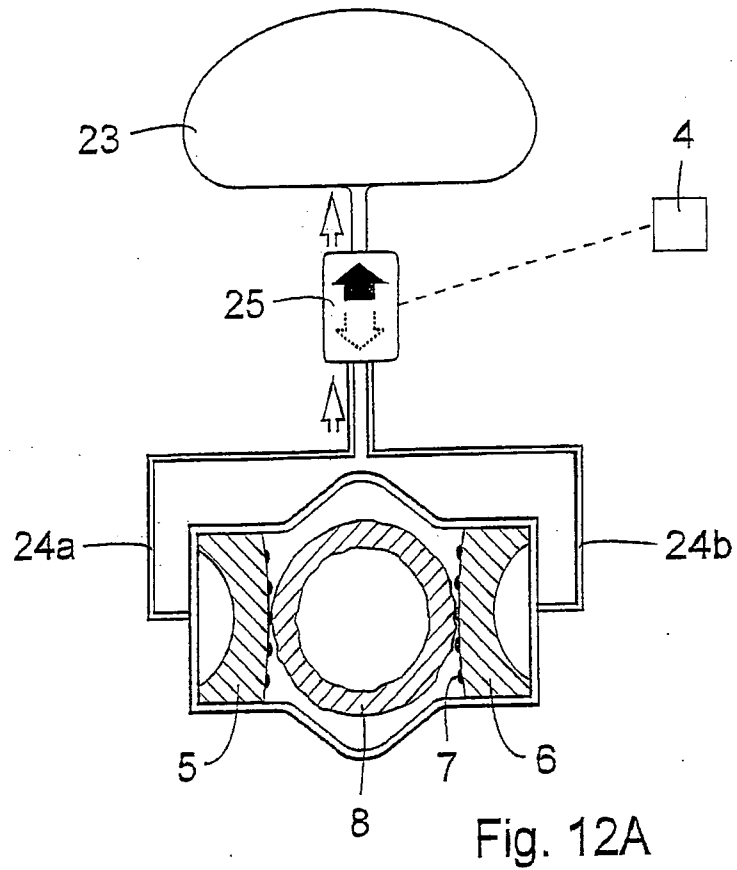

Fig. 11A



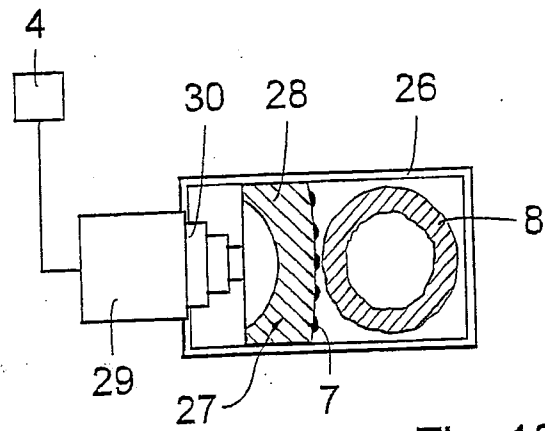

Fig. 13A

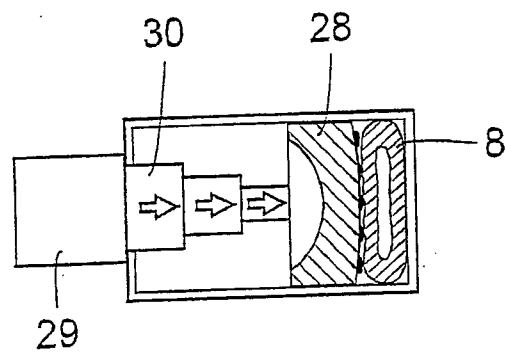

Fig. 13B

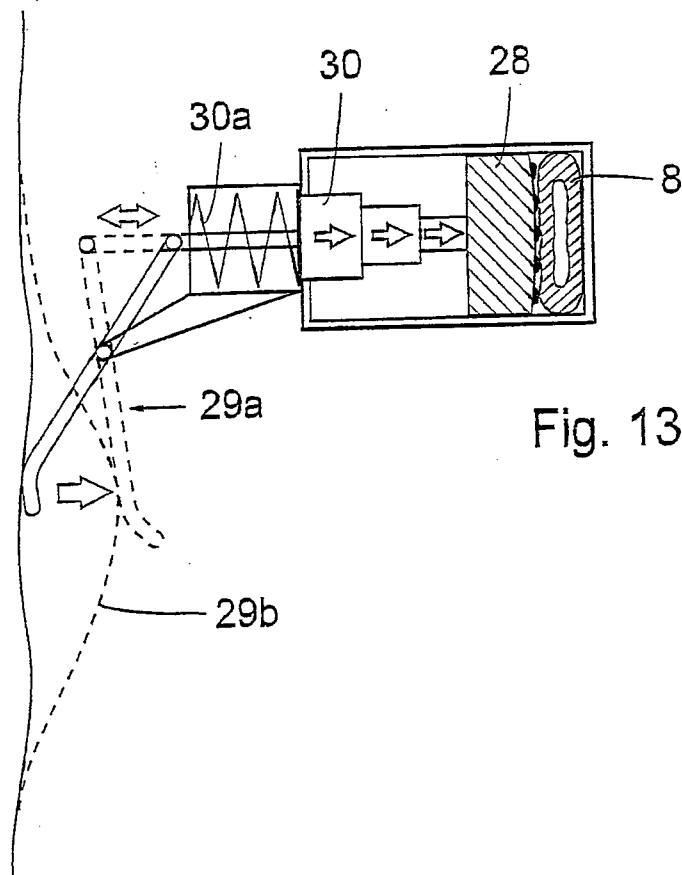

Fig. 13C

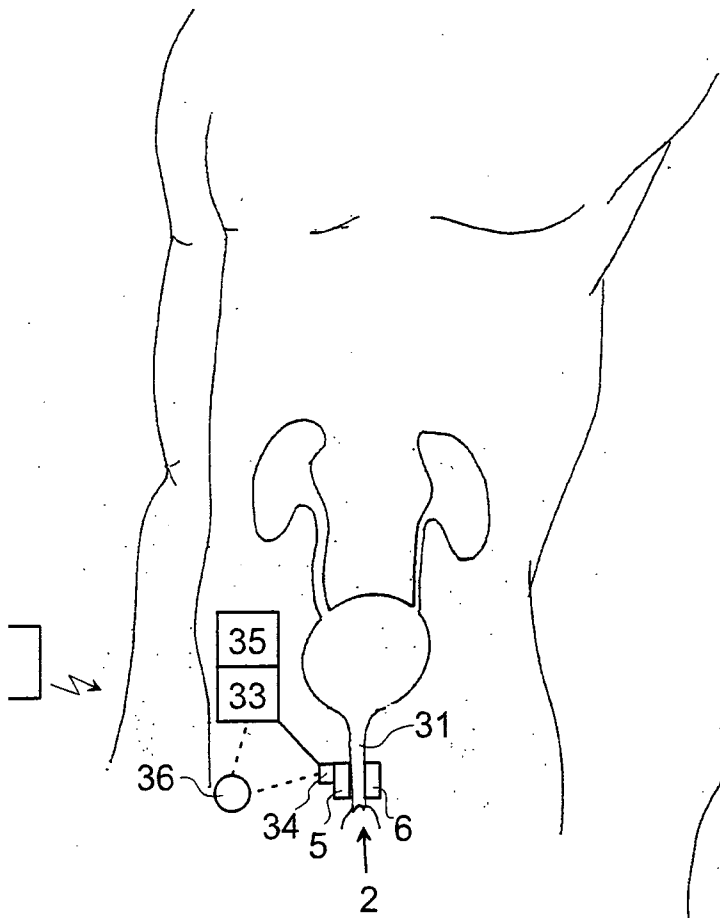

Fig. 14A

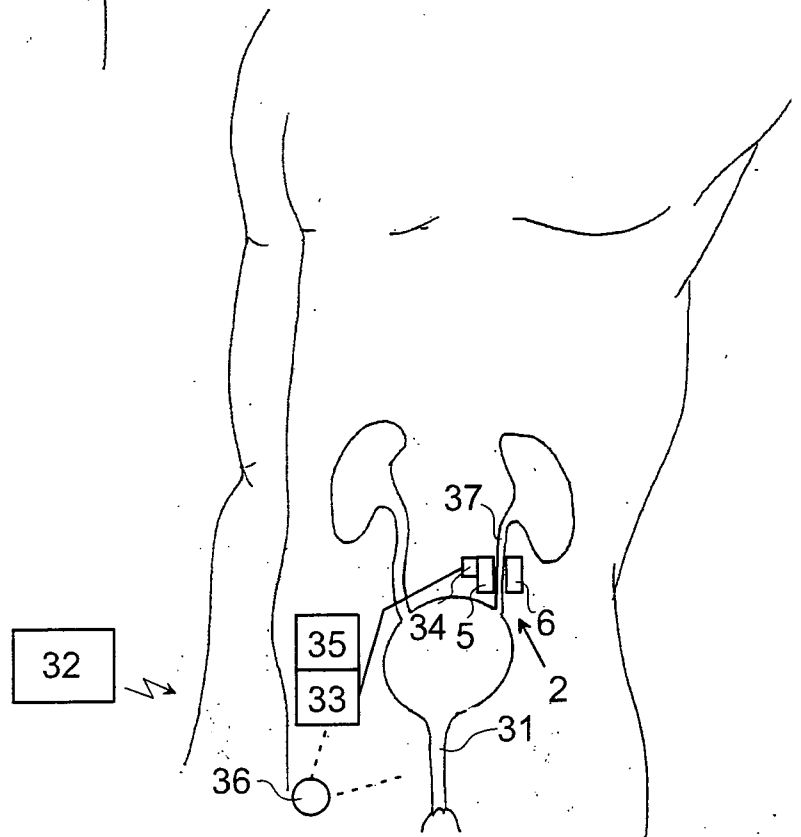

Fig. 14B

Fig. 14C

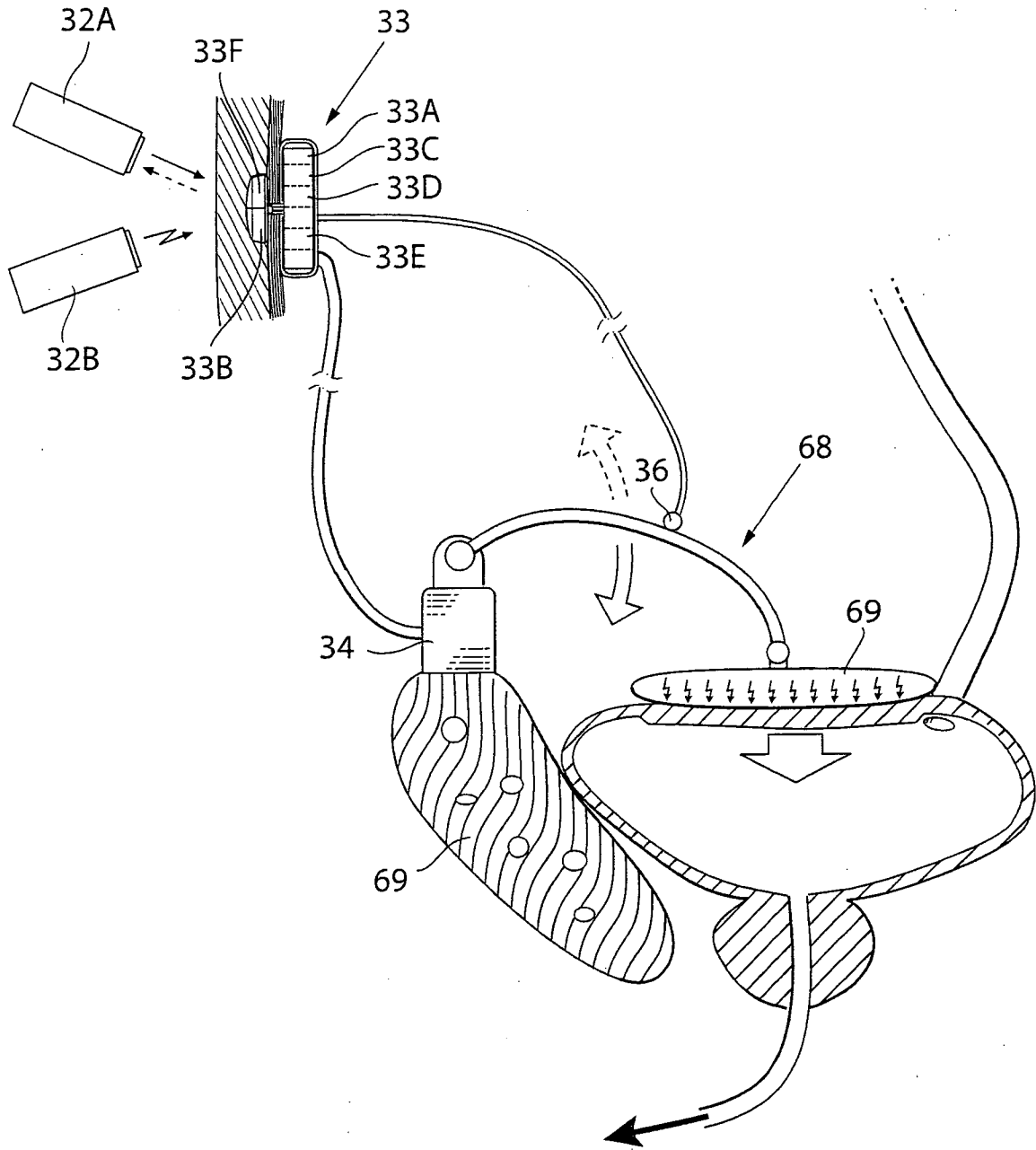
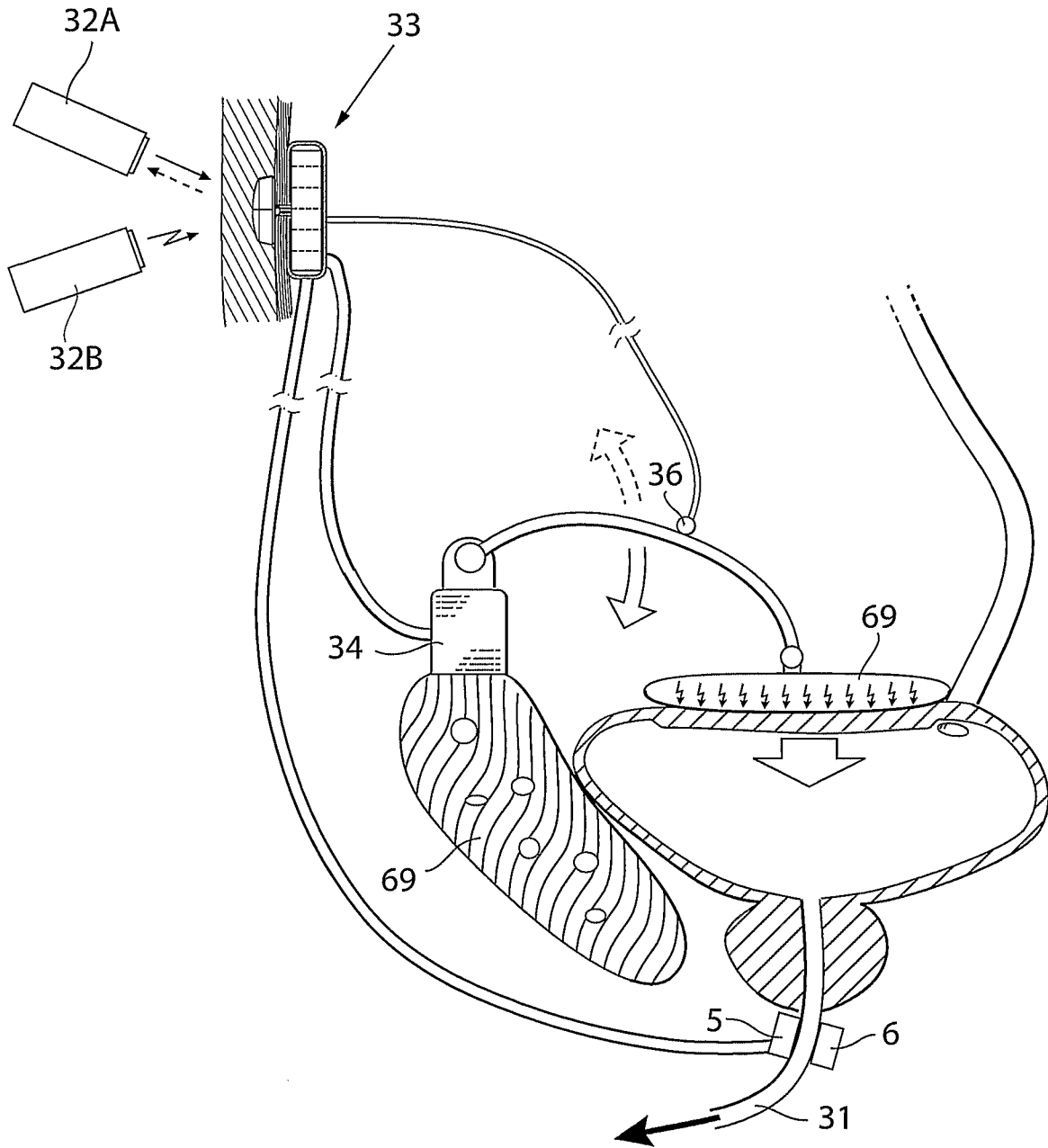



Fig. 14D



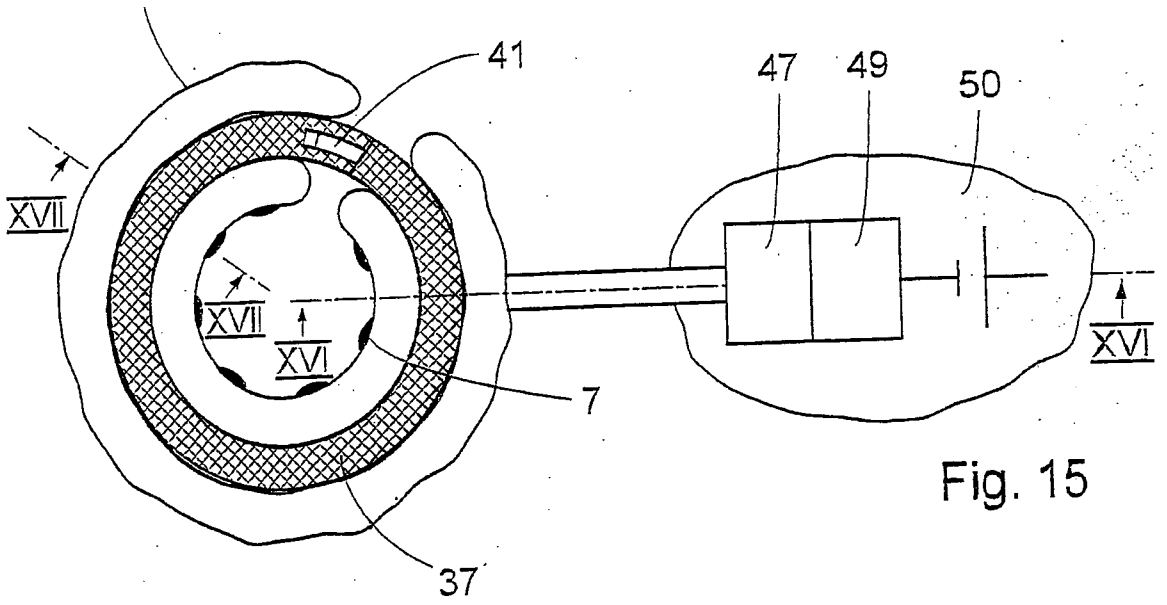

Fig. 15

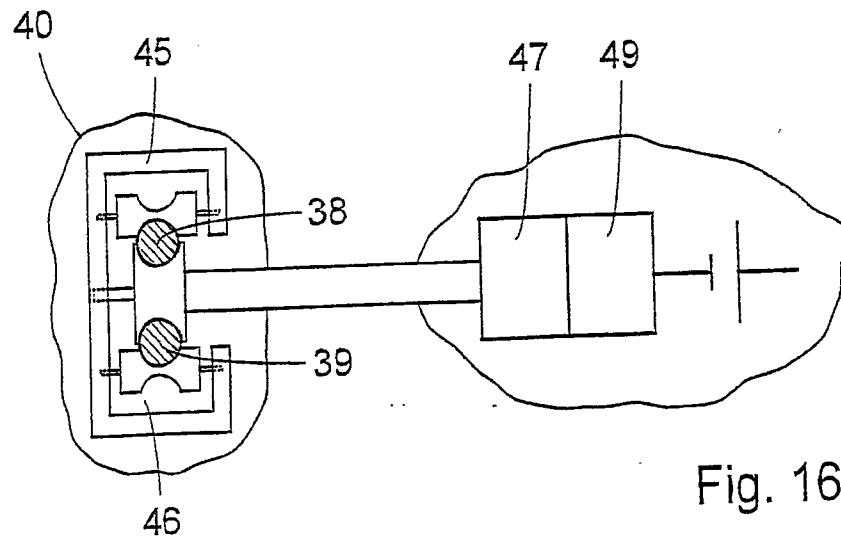

Fig. 16

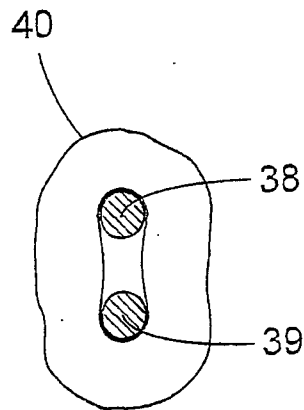

Fig. 17

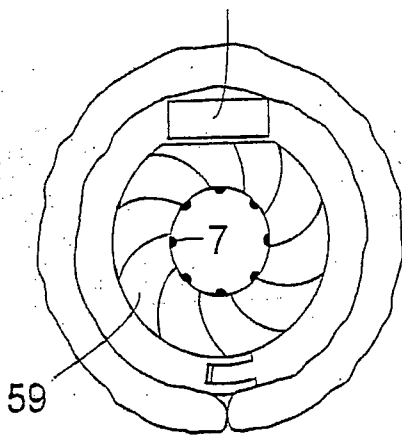

Fig. 20

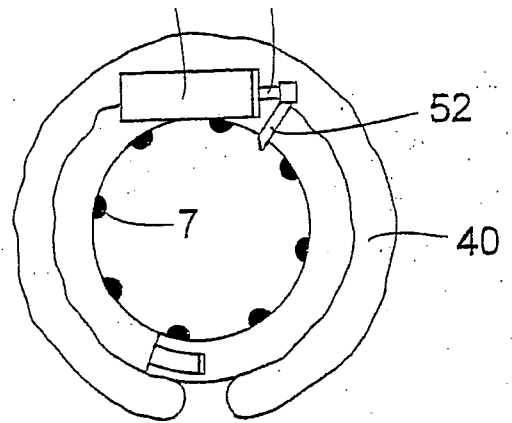

Fig. 18

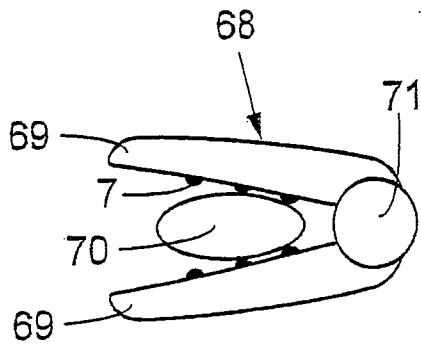

Fig. 27

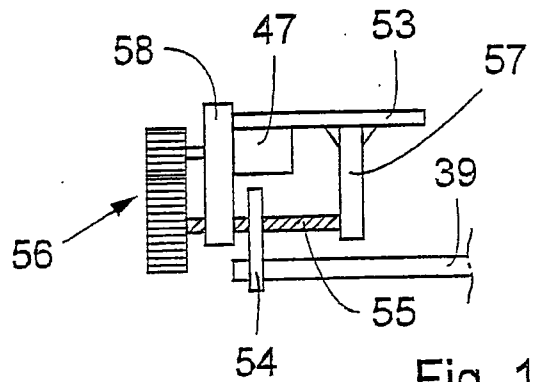

Fig. 19

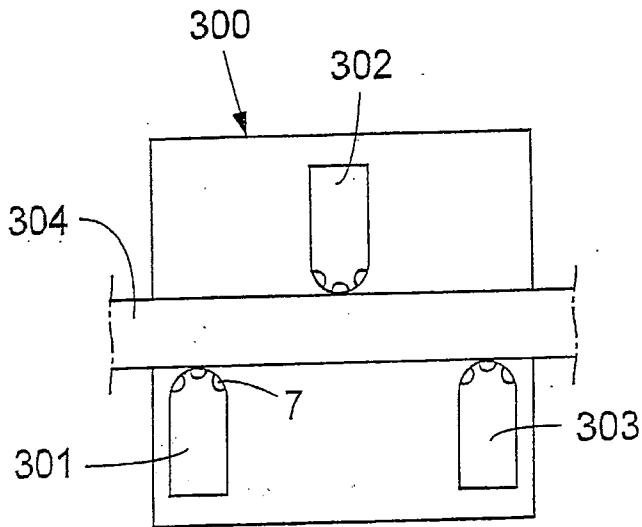

Fig. 28

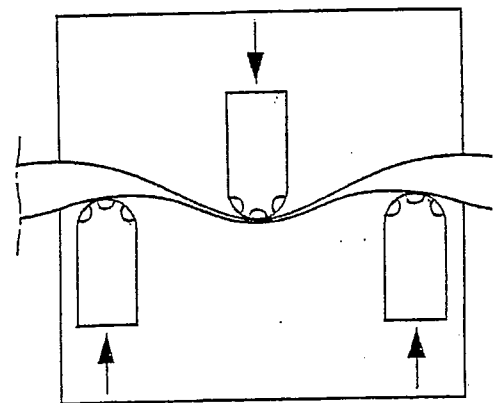

Fig. 29

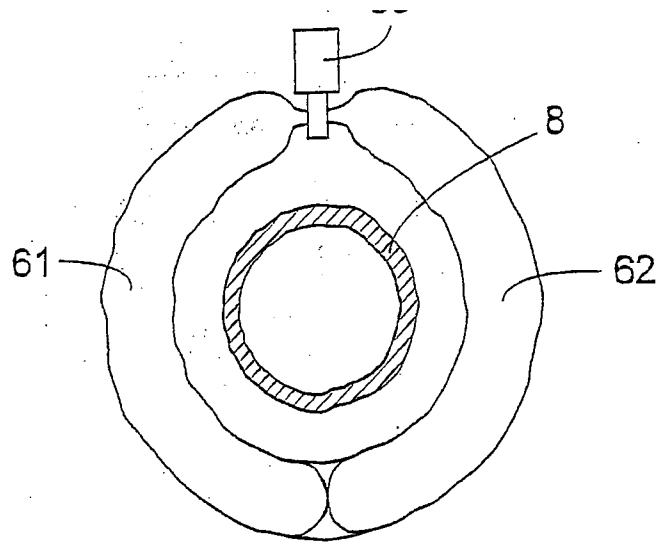

Fig. 21

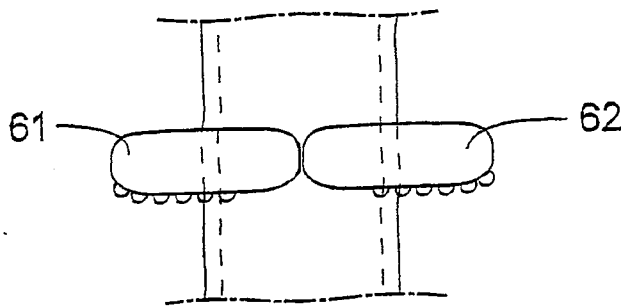

Fig. 22

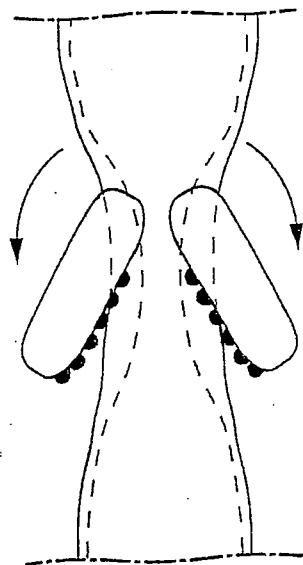

Fig. 23

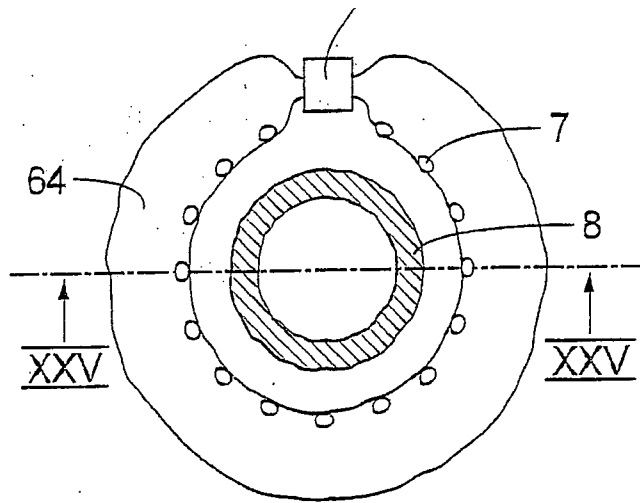

Fig. 24

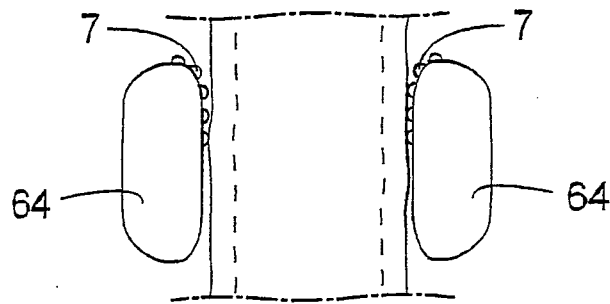

Fig. 25

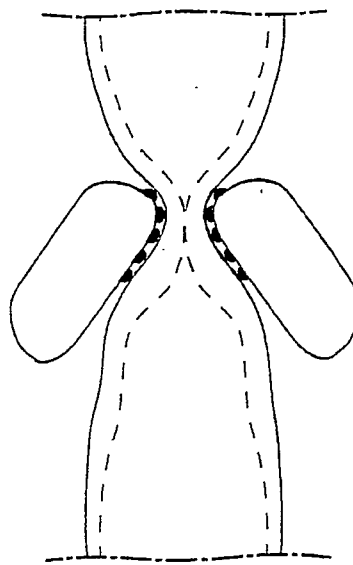

Fig. 26

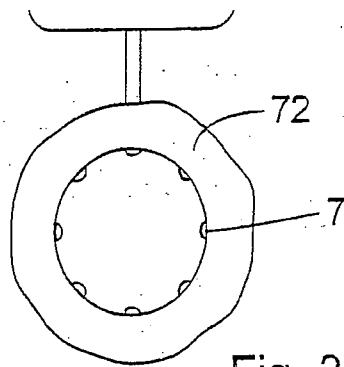

Fig. 30A

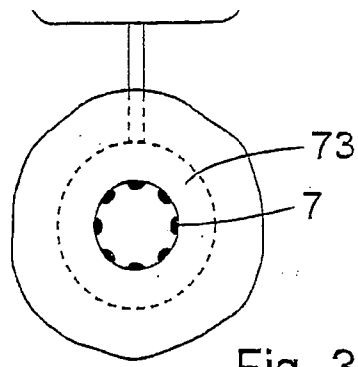

Fig. 30B

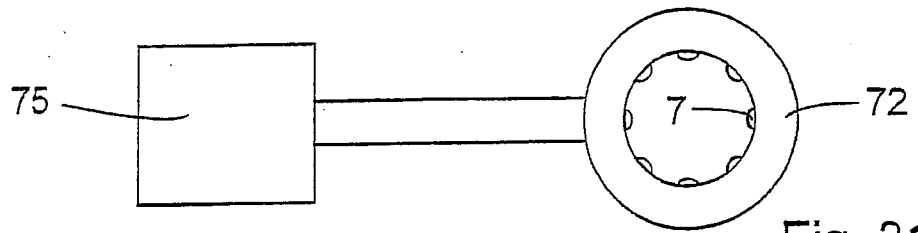

Fig. 31A

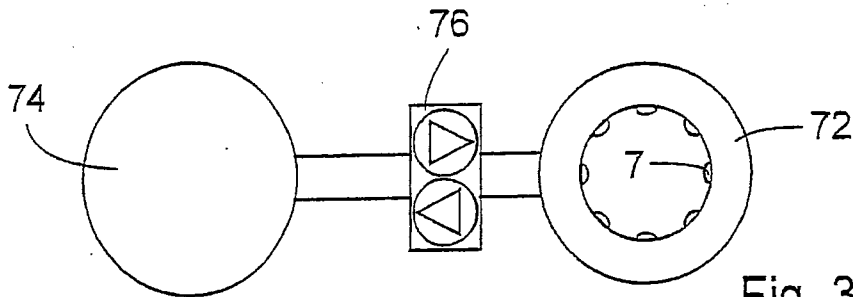

Fig. 31B

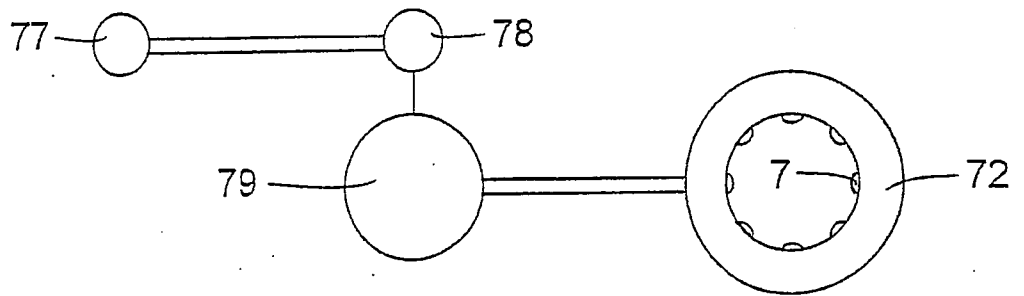

Fig. 31C

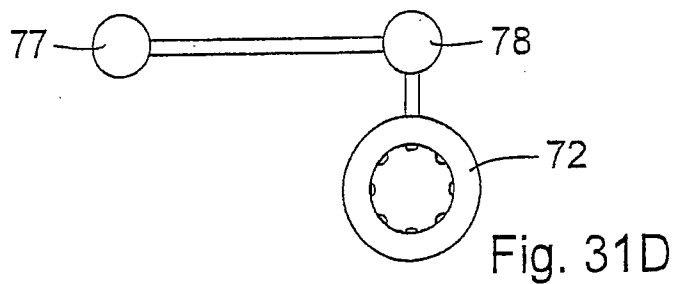

Fig. 31D

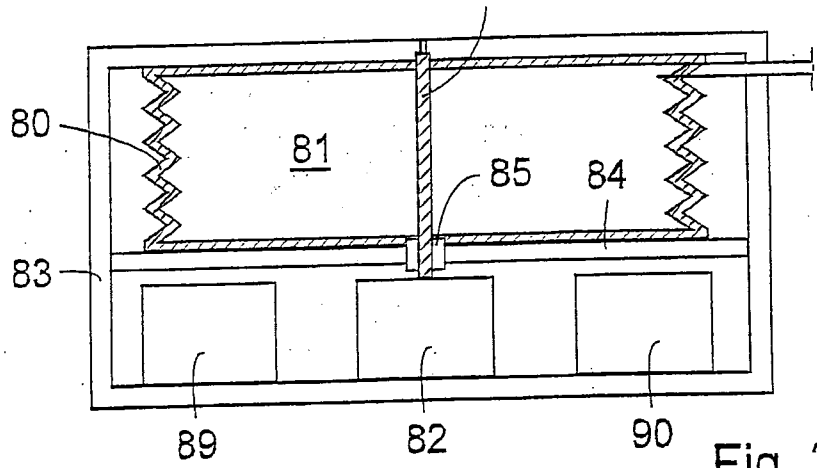

Fig. 32

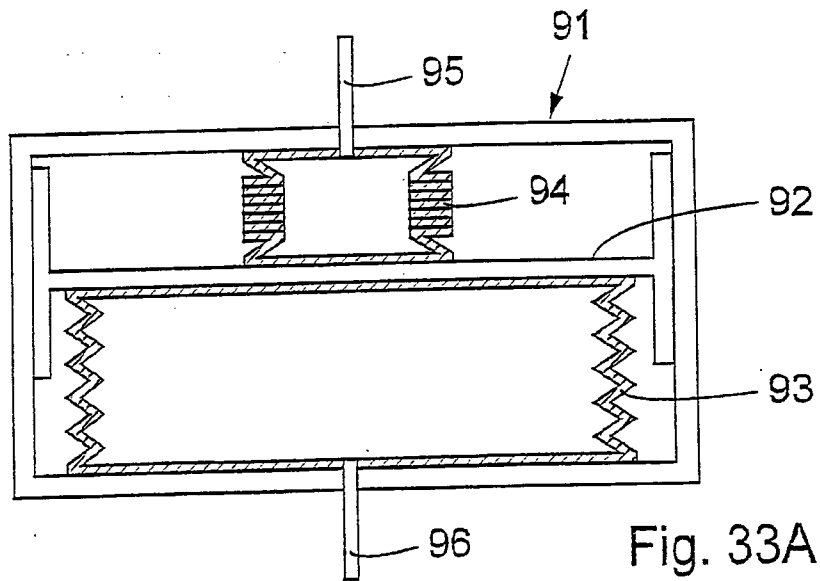

Fig. 33A

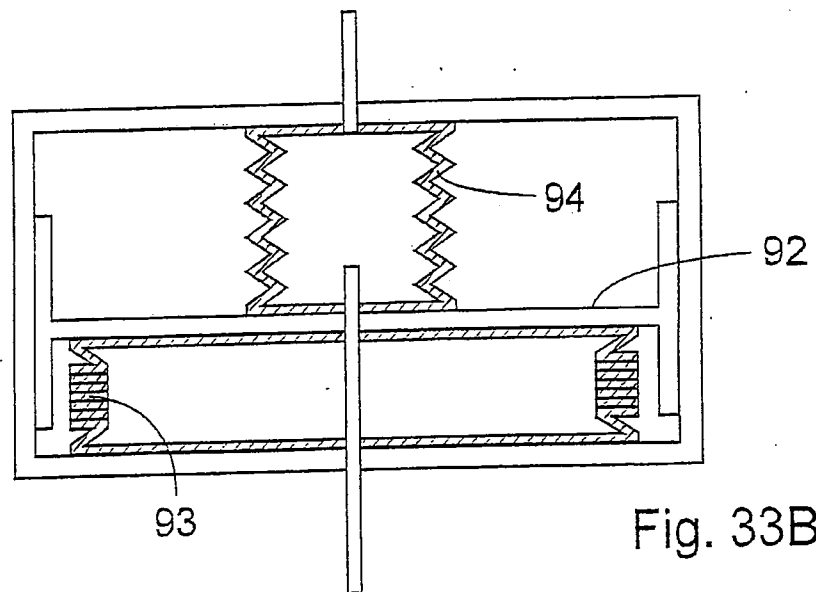
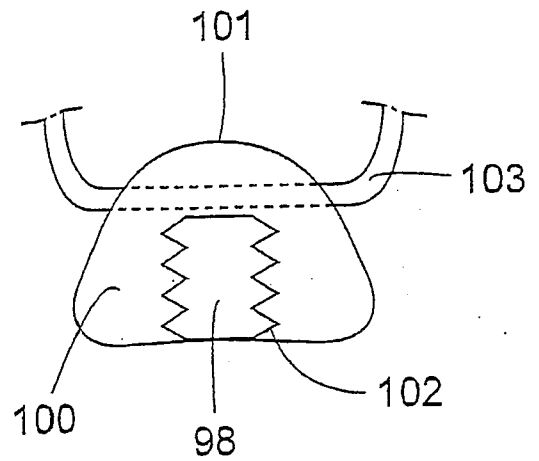
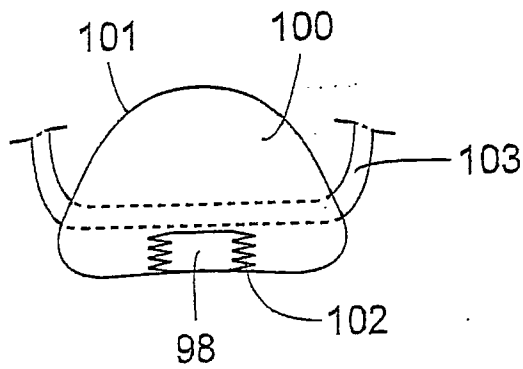
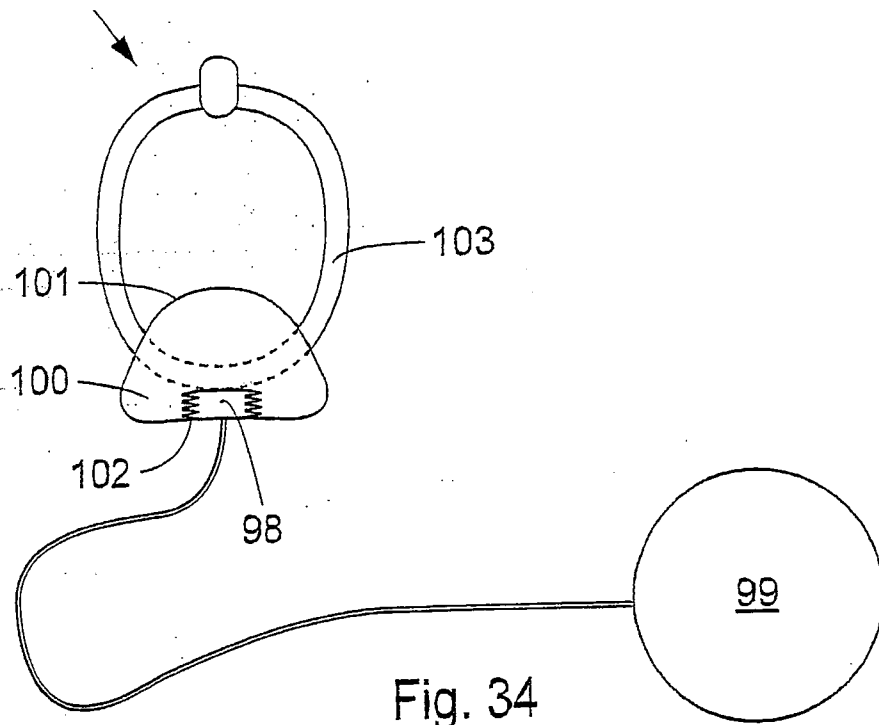
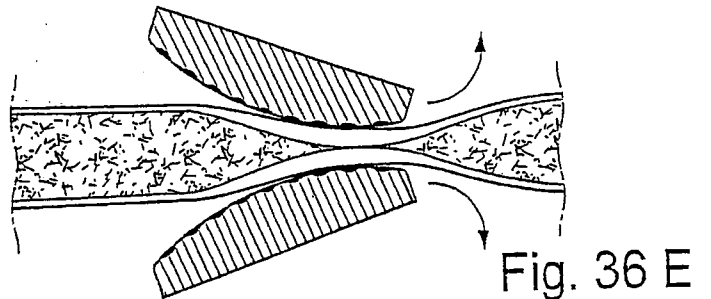
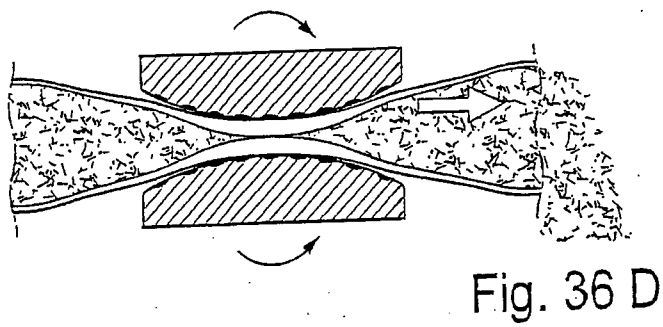
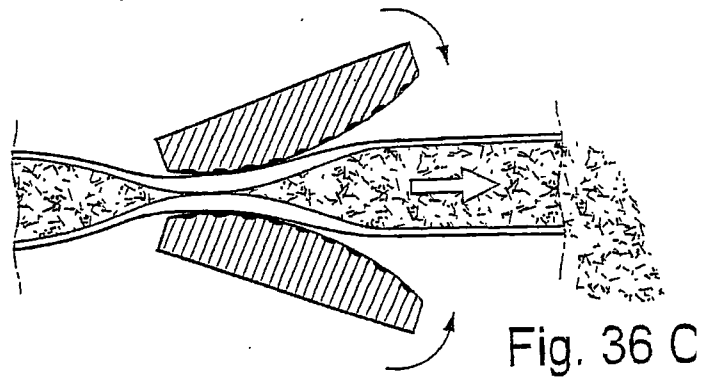
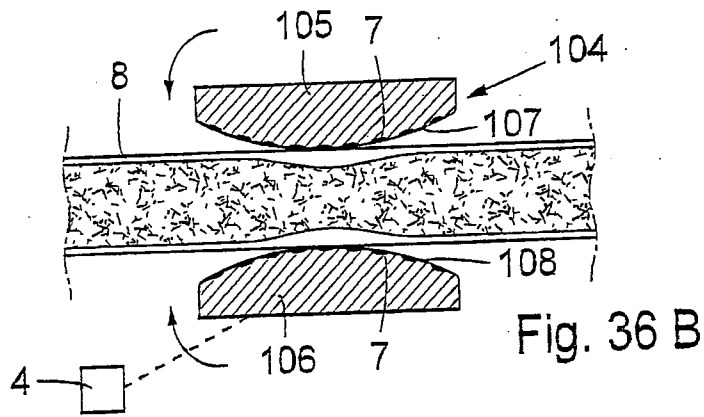
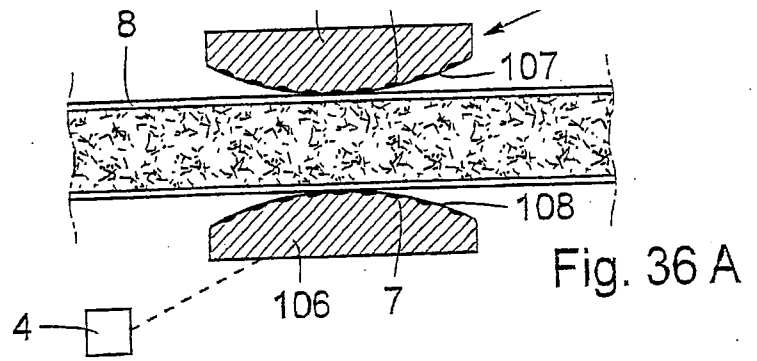

Fig. 33B







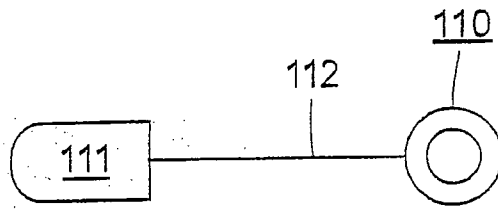

Fig. 37

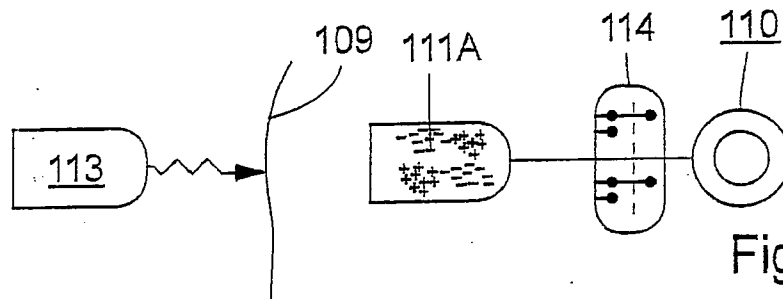

Fig. 38

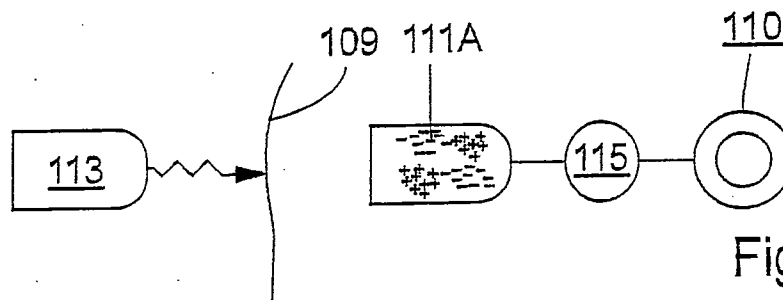

Fig. 39

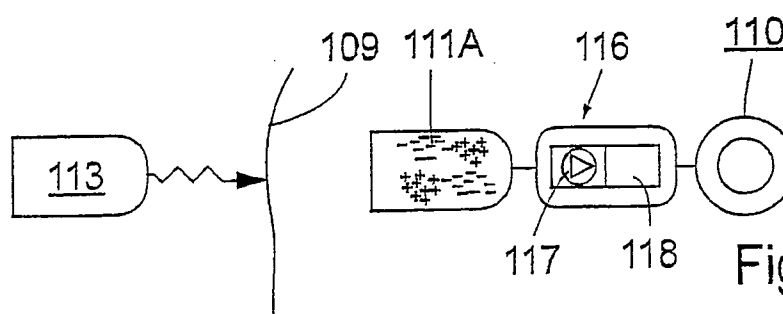

Fig. 40

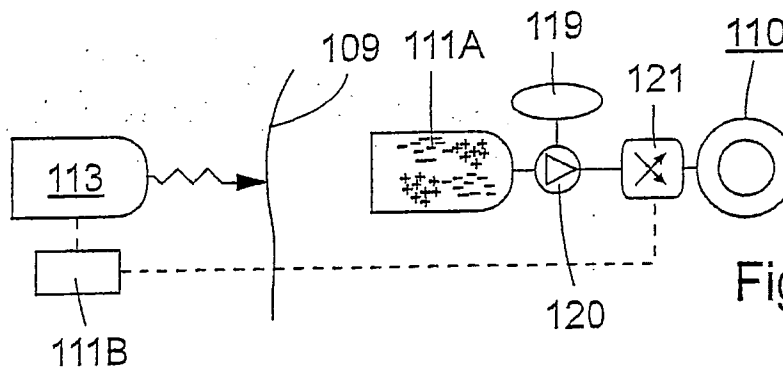
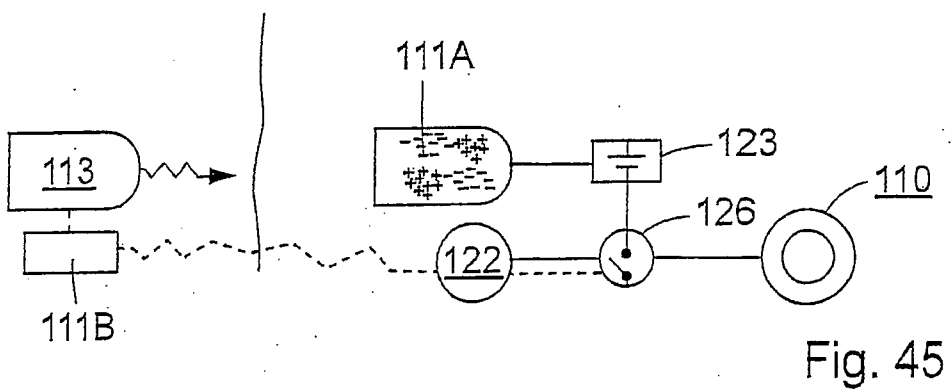
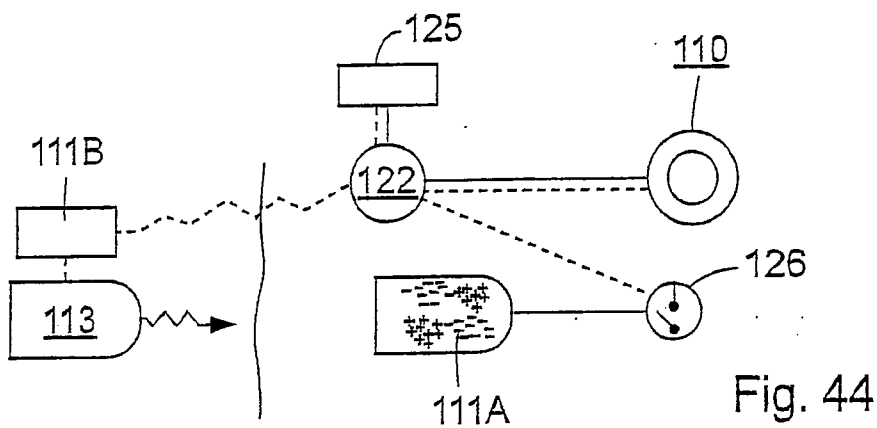
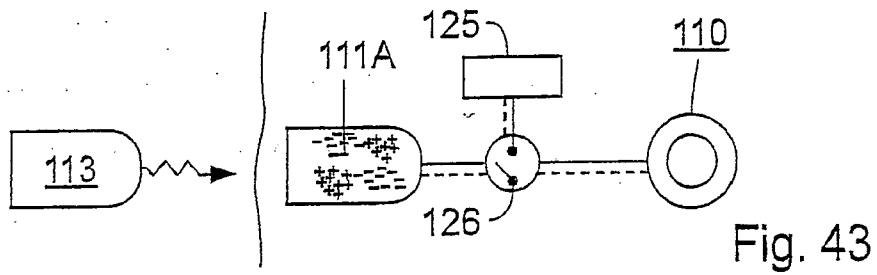
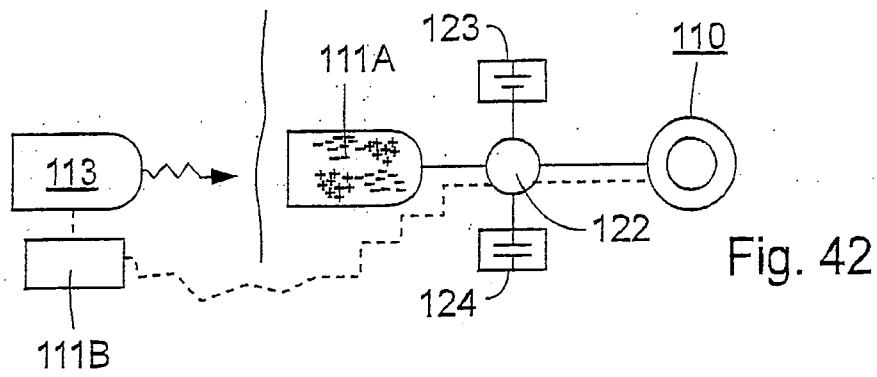

Fig. 41



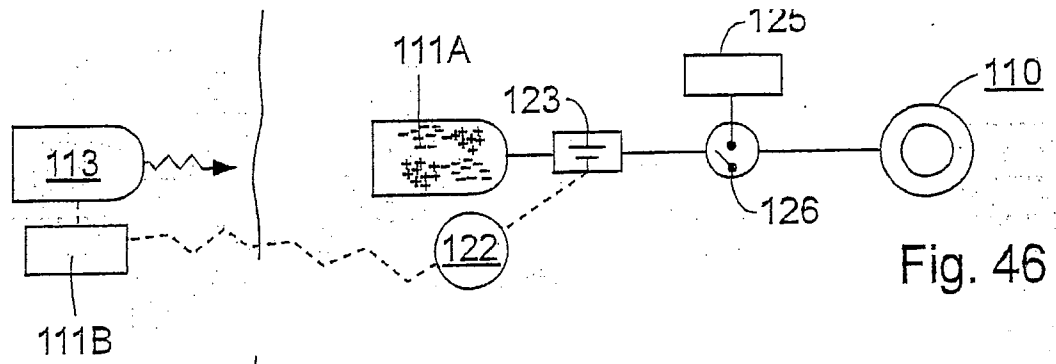

Fig. 46

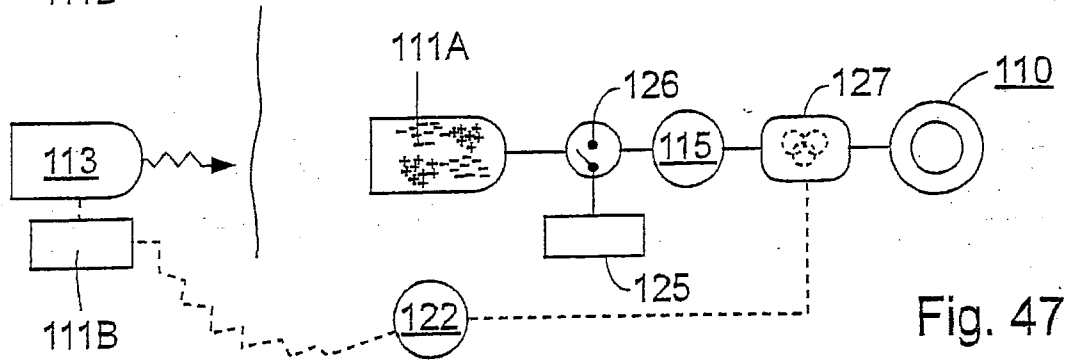

Fig. 47

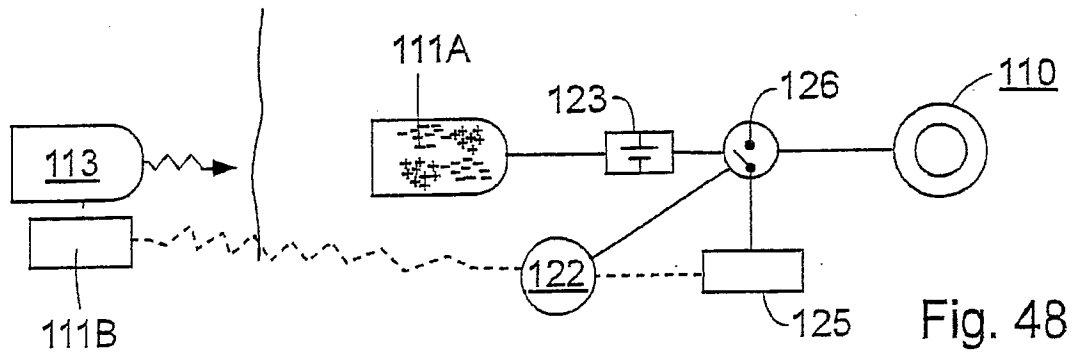

Fig. 48

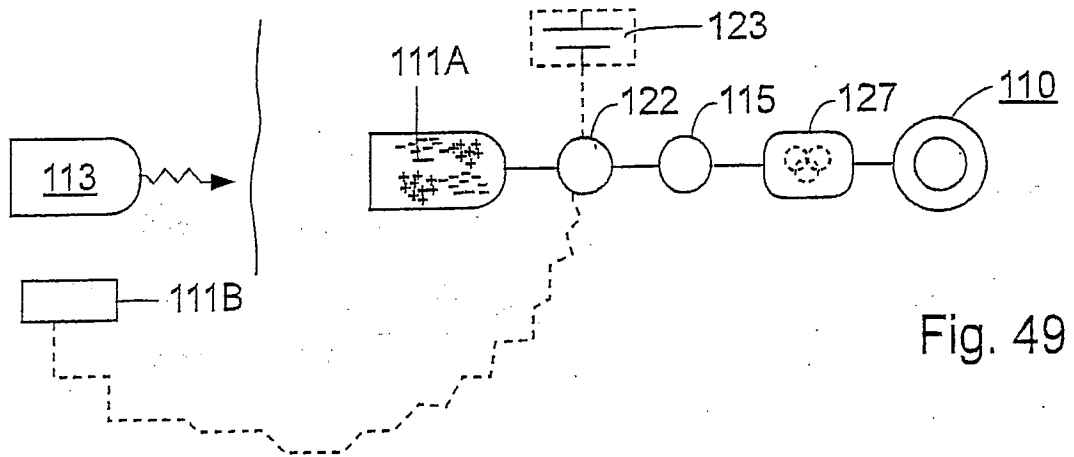

Fig. 49

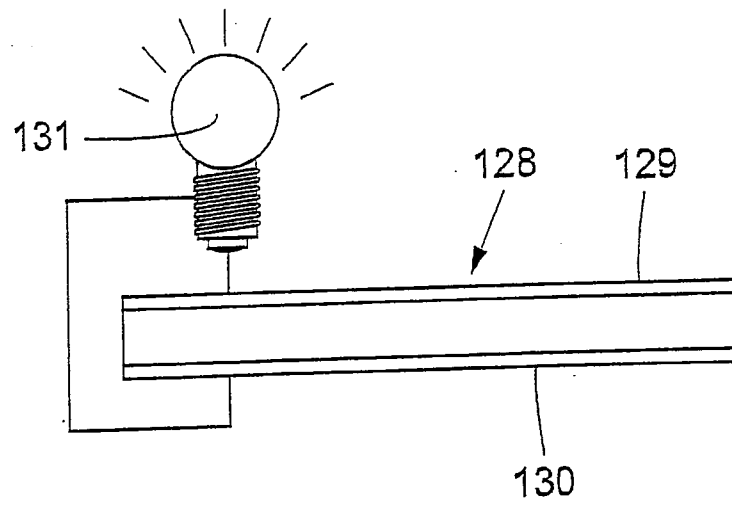

Fig. 50

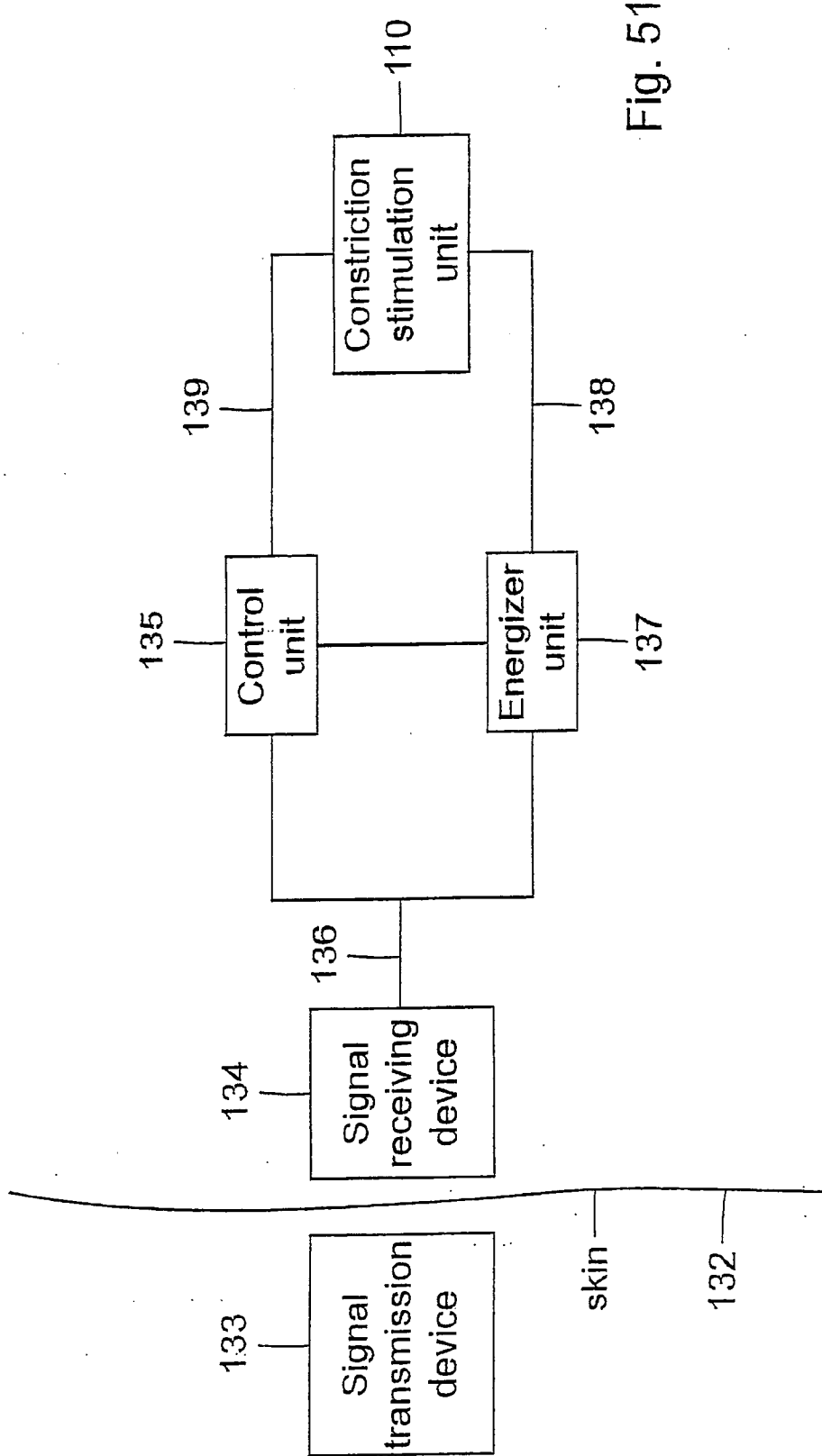

Fig. 51

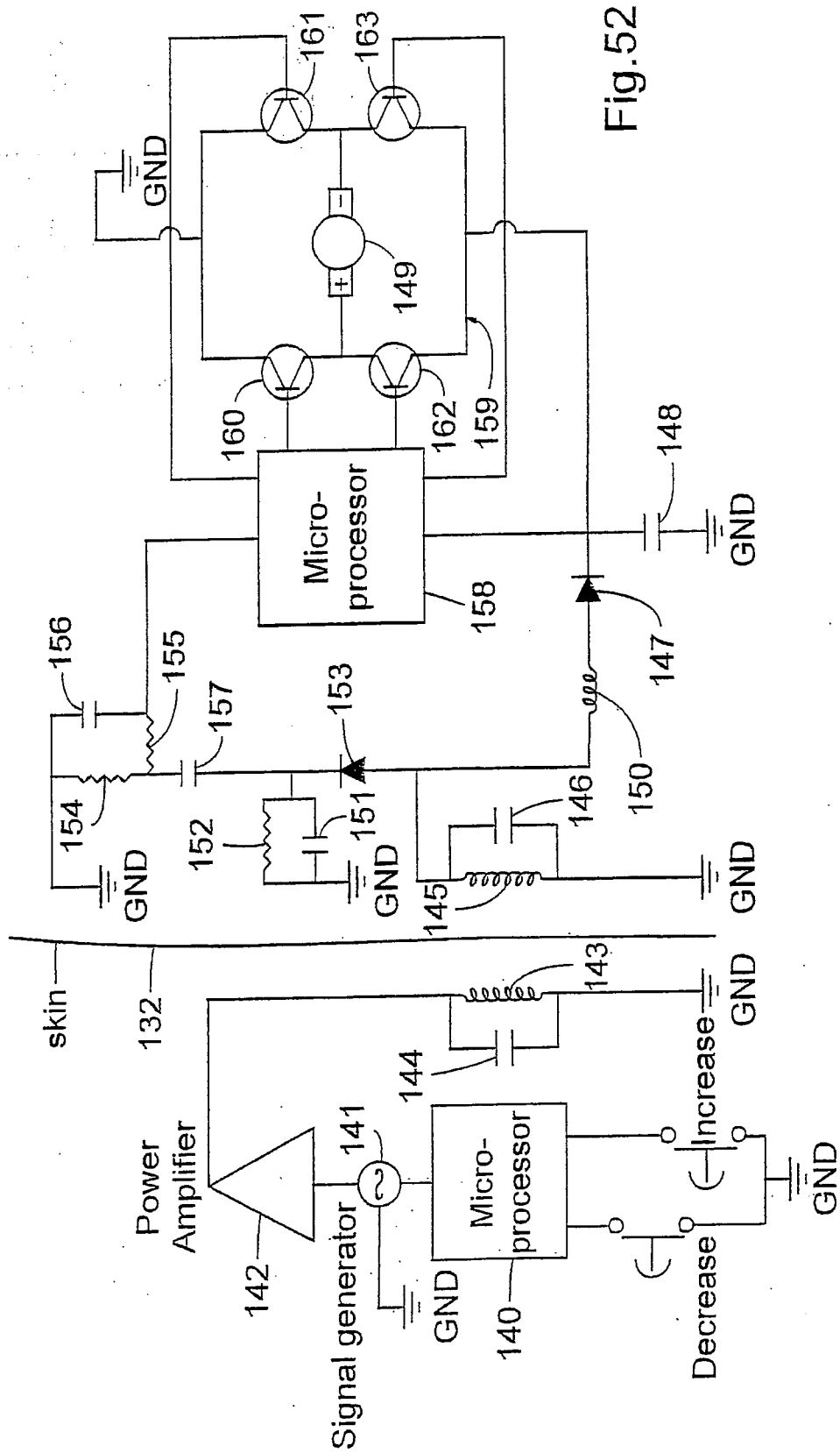

Fig. 52

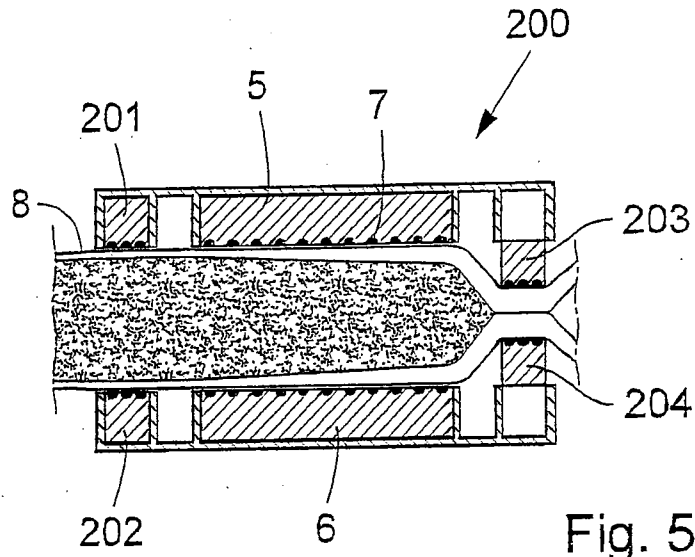

Fig. 53A

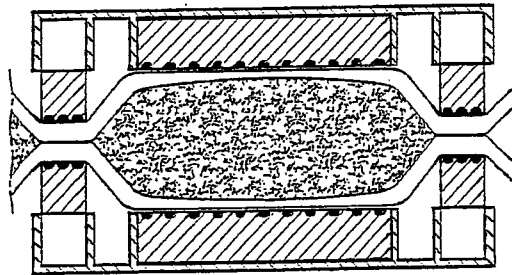

Fig. 53B

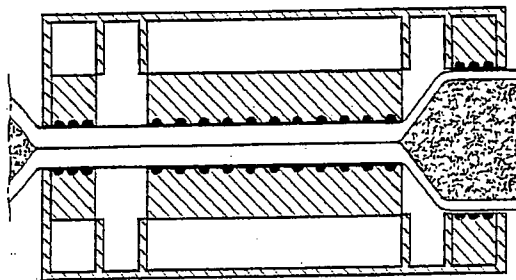

Fig. 53C



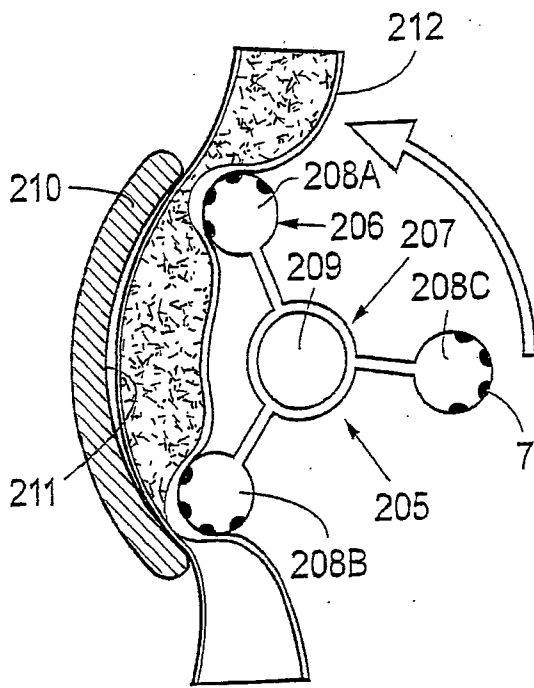

Fig. 54A

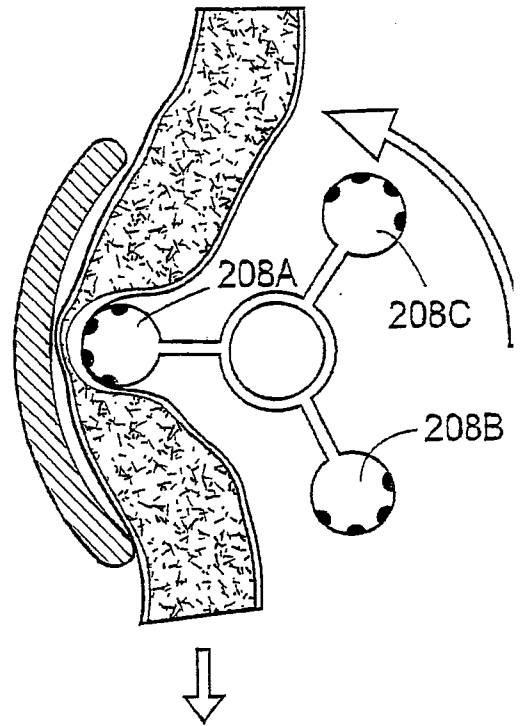

Fig. 54B

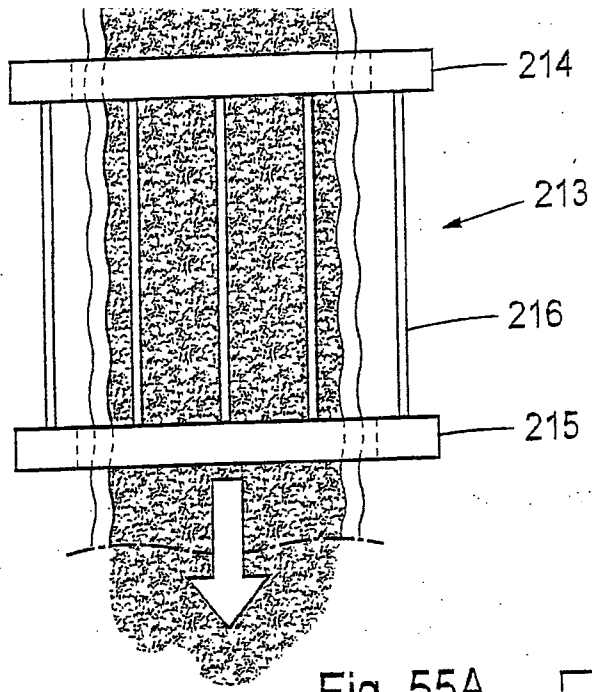

Fig. 55A

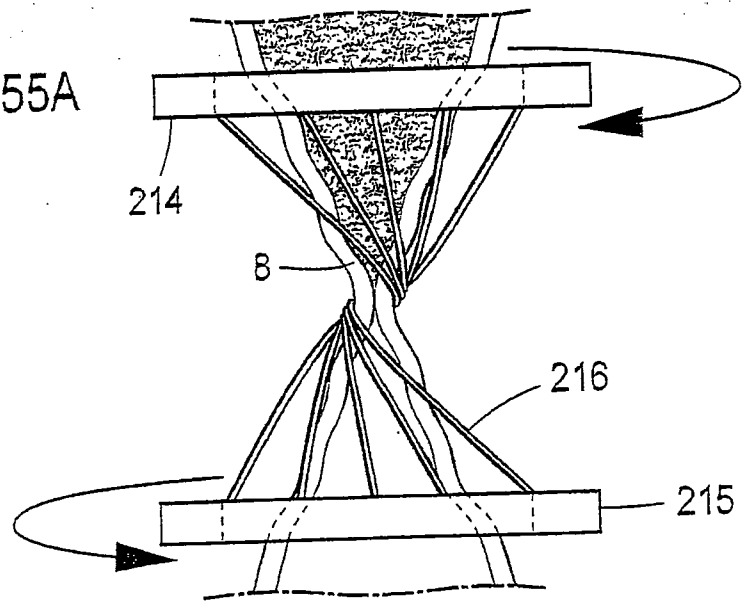

Fig. 55B

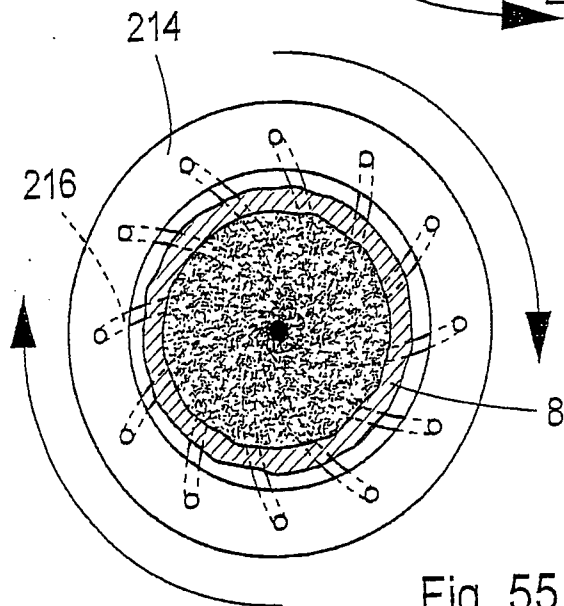

Fig. 55 C

Fig.56

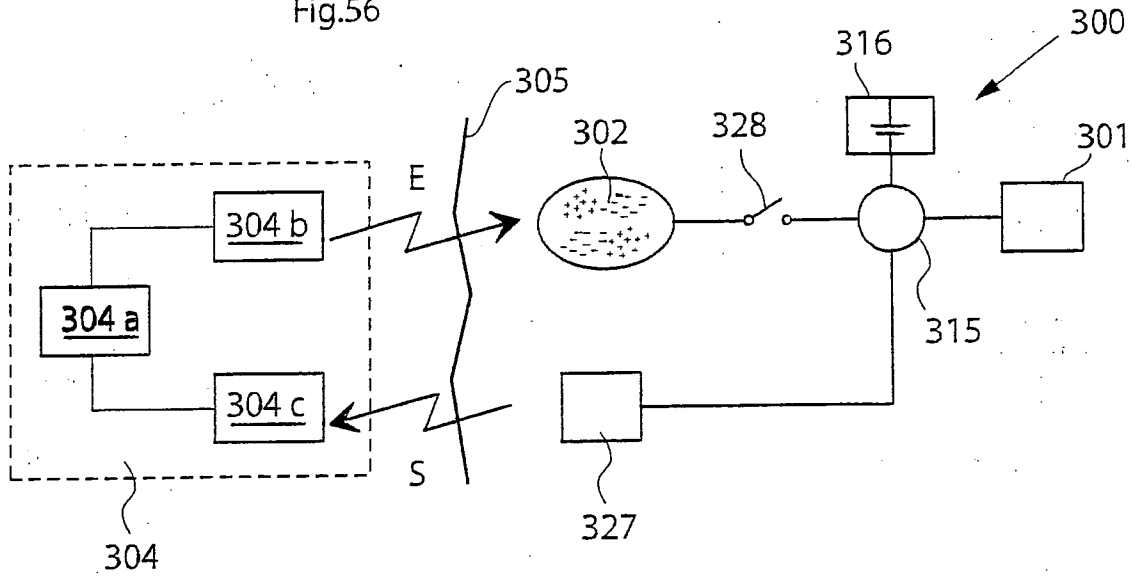

Fig.59

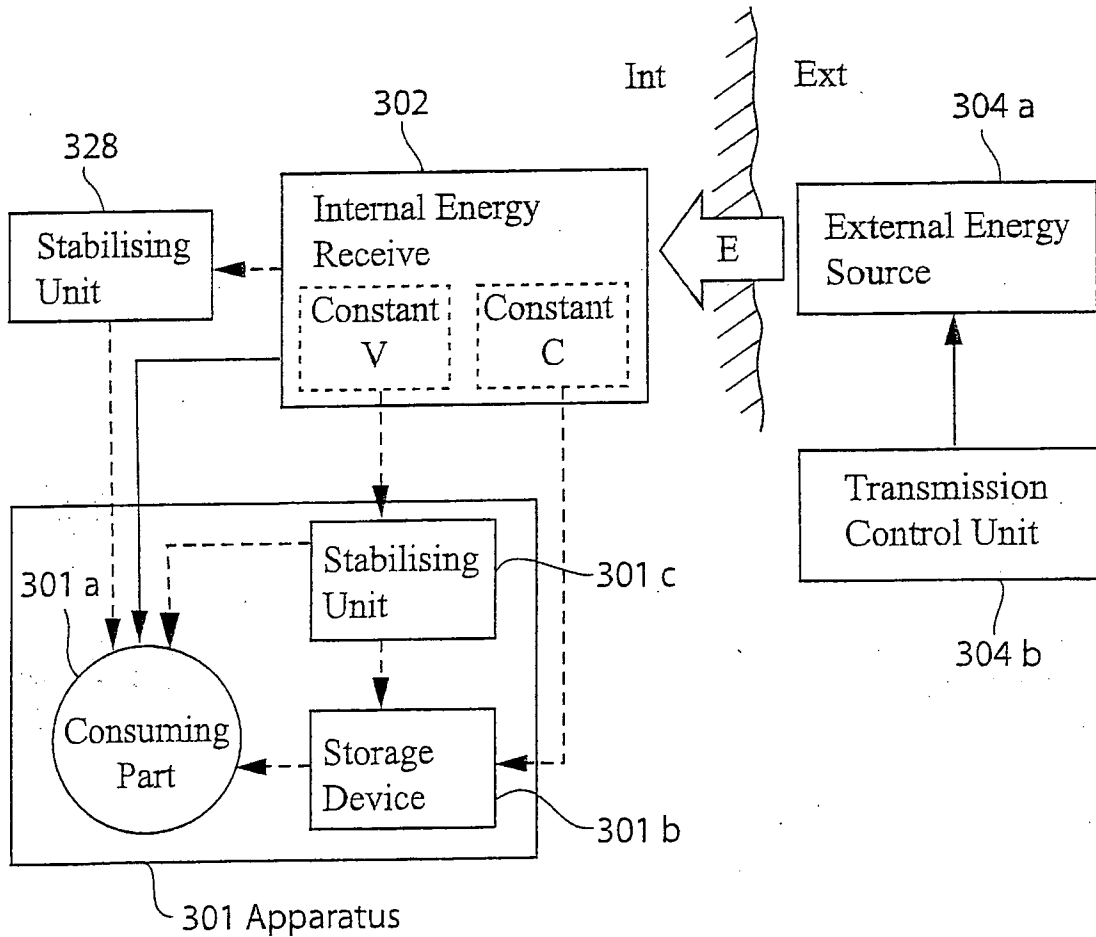

Fig.58

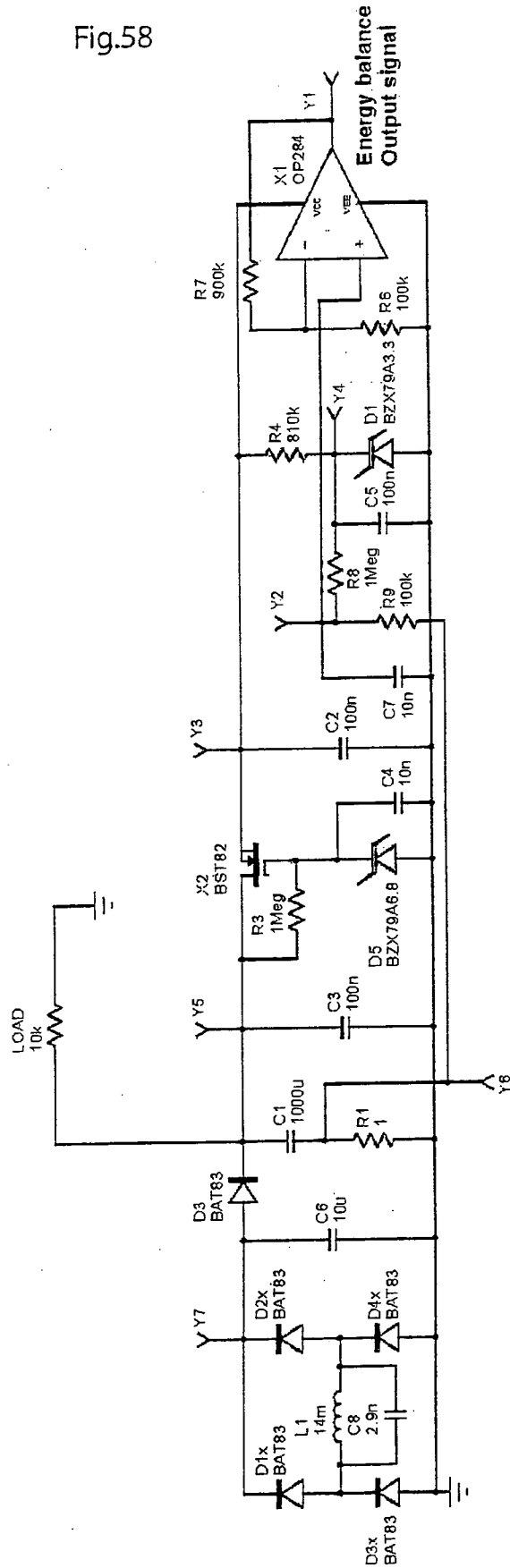
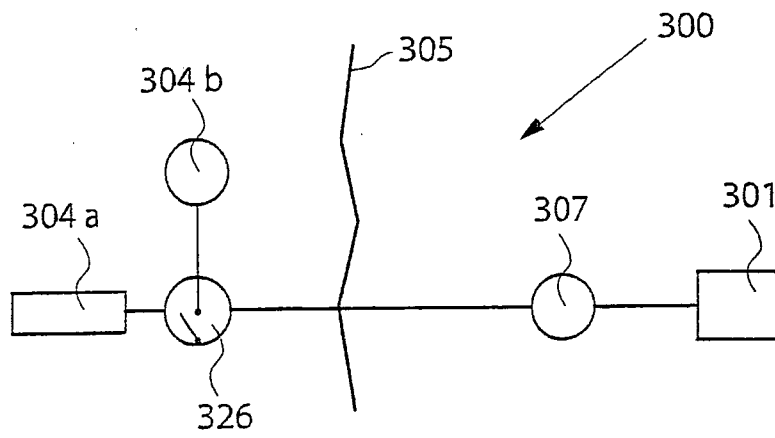

Fig. 57



## INTERNATIONAL SEARCH REPORT

International application No.

PCT/SE2008/000564

## A. CLASSIFICATION OF SUBJECT MATTER

IPC: see extra sheet

According to International Patent Classification (IPC) or to both national classification and IPC

## B. FIELDS SEARCHED

Minimum documentation searched (classification system followed by classification symbols)

IPC: A61B, A61F, A61N

Documentation searched other than minimum documentation to the extent that such documents are included in the fields searched

SE,DK,FI,NO classes as above

Electronic data base consulted during the international search (name of data base and, where practicable, search terms used)

EPO-INTERNAL, WPI DATA, PAJ

## C. DOCUMENTS CONSIDERED TO BE RELEVANT

Category*	Citation of document, with indication, where appropriate, of the relevant passages	Relevant to claim No.
X	US 20040242956 A1 (S.K. SCORVO), 2 December 2004 (02.12.2004), figures 9,12, paragraphs (0083), (0086-(0089)	1,4-6,36-41, 121-127,162, 207-244,
X		259-267,316
Y	Y: 288, 291-300	2,3,7-35, 42-56,65,66, 163-173, 248-258,
	--	

 Further documents are listed in the continuation of Box C.

 See patent family annex.

\* Special categories of cited documents:

"A" document defining the general state of the art which is not considered to be of particular relevance

"E" earlier application or patent but published on or after the international filing date

"L" document which may throw doubts on priority claim(s) or which is cited to establish the publication date of another citation or other special reason (as specified)

"O" document referring to an oral disclosure, use, exhibition or other means

"P" document published prior to the international filing date but later than the priority date claimed

"T" later document published after the international filing date or priority date and not in conflict with the application but cited to understand the principle or theory underlying the invention

"X" document of particular relevance: the claimed invention cannot be considered novel or cannot be considered to involve an inventive step when the document is taken alone

"Y" document of particular relevance: the claimed invention cannot be considered to involve an inventive step when the document is combined with one or more other such documents, such combination being obvious to a person skilled in the art

"&" document member of the same patent family

Date of the actual completion of the international search

11 March 2009

Date of mailing of the international search report

12-03-2009

Name and mailing address of the ISA/  
Swedish Patent Office  
Box 5055, S-102 42 STOCKHOLM  
Facsimile No. +46 8 666 02 86

Authorized officer

Leif Brander / MRO  
Telephone No. +46 8 782 25 00

## INTERNATIONAL SEARCH REPORT

International application No.

PCT/SE2008/000564

## C (Continuation). DOCUMENTS CONSIDERED TO BE RELEVANT

Category*	Citation of document, with indication, where appropriate, of the relevant passages	Relevant to claim No.
X	WO 03002192 A1 (SURGICAL DEVELOPMENT AG), 9 January 2003 (09.01.2003), figure 8, claims 1-106	316
Y	---	2, 3, 7-35, 42-56, 65, 66, 163-173,
Y	---	248-258, 288, 291-300
Y	WO 0145486 A2 (SURGICAL DEVELOPMENT AG), 28 June 2001 (28.06.2001), figures 1-3, claims 1-116	1-56, 65, 66, 121-127, 162-173, 207-244,
Y	---	248-279, 288, 291-300
A	US 4153059 A (R.P. FRAVEL ET AL), 8 May 1979 (08.05.1979)	1-244, 288-316
A	US 6896651 B2 (Y. GROSS ET AL), 24 May 2005 (24.05.2005)	1-244, 248-316
	-----	





**INTERNATIONAL SEARCH REPORT**

International application No.  
PCT/SE2008/000564

**Box II.1**

Nevertheless, a search has been made for this claim. The search has been directed to the technical content of the claim(s).

**International patent classification (IPC)****A61F 2/04** (2006.01)**A61B 17/12** (2006.01)**A61N 1/36** (2006.01)**Download your patent documents at [www.prv.se](http://www.prv.se)**

The cited patent documents can be downloaded at [www.prv.se](http://www.prv.se) by following the links:

- In English/Searches and advisory services/Cited documents (service in English) or
- e-tjänster/anförda dokument (service in Swedish).

Use the application number as username.

The password is **TVKJISMKYV**.

Paper copies can be ordered at a cost of 50 SEK per copy from PRV InterPat (telephone number 08-782 28 85).

Cited literature, if any, will be enclosed in paper form.

## INTERNATIONAL SEARCH REPORT

Information on patent family members

International application No.

01/11/2008

PCT/SE2008/000564

US	20040242956	A1	02/12/2004	NONE		
-----						
WO	03002192	A1	09/01/2003	AU	9618801 A	06/05/2002
				CA	2451853 A	09/01/2003
				EP	1399216 A	24/03/2004
				SE	0102312 D	00/00/0000
				US	20030009201 A	09/01/2003
				US	20040172087 A	02/09/2004
-----						
WO	0145486	A2	28/06/2001	AT	348579 T	15/01/2007
				AU	3255901 A	03/07/2001
				DE	60125351 D,T	16/05/2007
				EP	1284691 A,B	26/02/2003
				EP	1586283 A	19/10/2005
				EP	1759665 A	07/03/2007
				EP	1792583 A	06/06/2007
				US	6709385 B	23/03/2004
				US	20030144575 A	31/07/2003
-----						
US	4153059	A	08/05/1979	NONE		
-----						
US	6896651	B2	24/05/2005	US	7387603 B	17/06/2008
				US	20020062060 A	23/05/2002
				US	20050113881 A	26/05/2005
				US	20080242918 A	02/10/2008
				AT	328548 T	15/06/2006
				AT	358454 T	15/04/2007
				AT	416716 T	15/12/2008
				AU	6118699 A	26/04/2000
				AU	6118799 A	26/04/2000
				DE	69931797 D,T	24/05/2007
				DE	69935727 D,T	27/12/2007
				DE	69940084 D	00/00/0000
				EP	1119314 A,B	01/08/2001
				EP	1124502 A,B	22/08/2001
				EP	1702587 A,B	20/09/2006
				EP	2011453 A	07/01/2009
				US	6354991 B	12/03/2002
				US	6652449 B	25/11/2003
				US	20050261746 A	24/11/2005
				WO	0019939 A	13/04/2000
				IL	127481 A	12/05/2004
				WO	0019940 A	13/04/2000
-----						