

F. W. WILLIAMS.  
 PICTURE FRAME.  
 APPLICATION FILED FEB. 23, 1910.

975,094.

Patented Nov. 8, 1910.

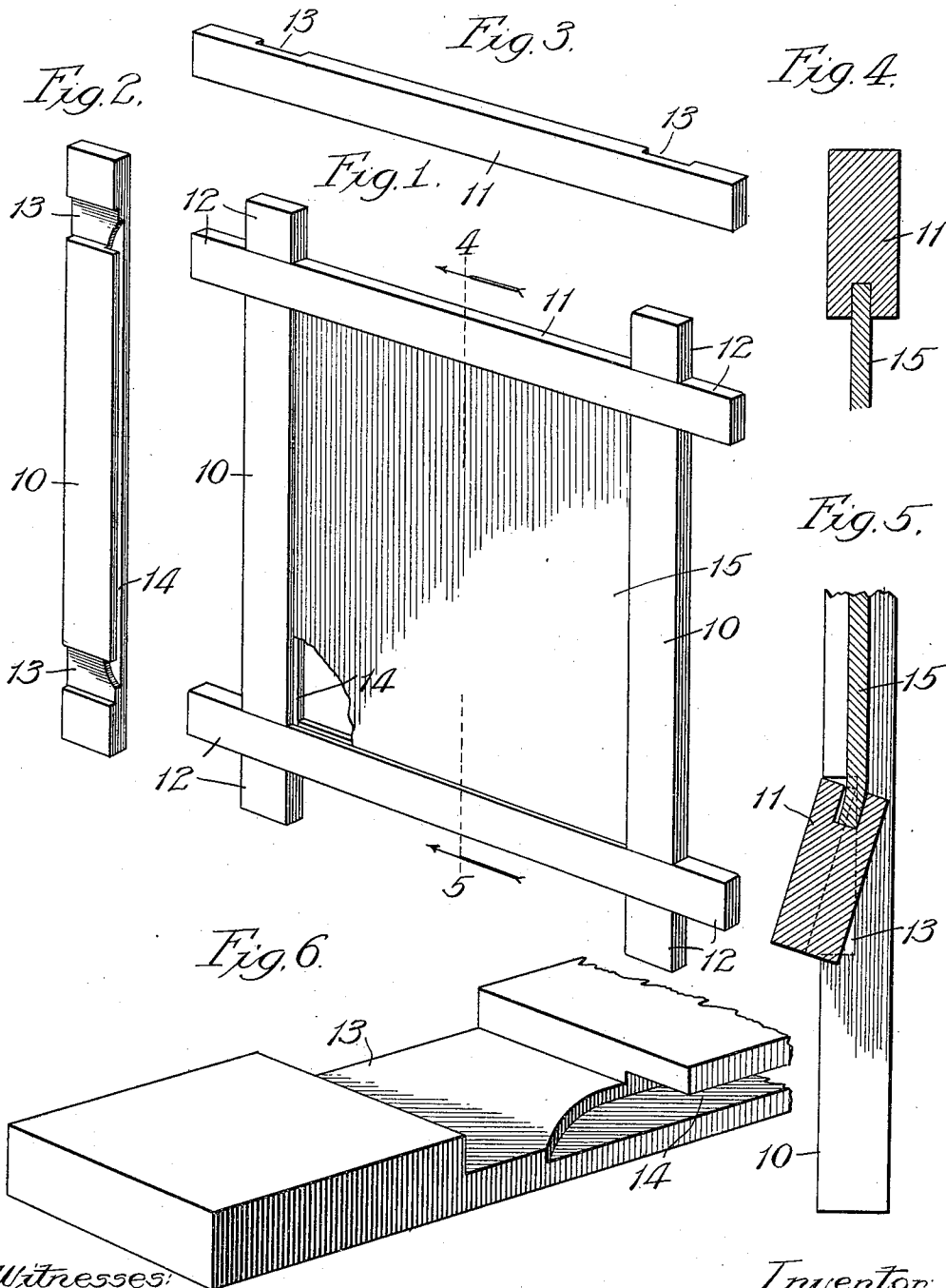

Witnesses:

John Enders  
 Chas. H. Bull.

Inventor:

Frank W. Williams.  
 By Depue, Smith, Lee, Chittow & Miles,  
 Attys. 44

# UNITED STATES PATENT OFFICE.

FRANK W. WILLIAMS, OF CHICAGO, ILLINOIS.

## PICTURE-FRAME.

975,094.

Specification of Letters Patent.

Patented Nov. 8, 1910.

Application filed February 23, 1910. Serial No. 545,389.

To all whom it may concern:

Be it known that I, FRANK W. WILLIAMS, a citizen of the United States, residing at Chicago, in the county of Cook and State of Illinois, have invented a new and useful Improvement in Picture-Frames, of which the following is a specification.

My invention relates to improvements in frames for display-cards, advertising pictures, or the like.

It is the practice among brewers and certain other advertisers to show their advertisements upon pictures or display-cards mounted in more or less ornate frames, and in the past such advertisers have experienced loss and annoyance from the fact that the frames employed could readily be used by unauthorized persons to contain pictures, or the like, for their own private uses. To obviate this difficulty, some advertisers have employed the expedient of branding the frames with their names but this practice is objectionable because it injures the appearance of the frame and consequently of the display they desire to make.

My object is to prevent this loss and annoyance to advertisers by providing means whereby when the frame and picture, or the like, are once assembled, the picture cannot be removed without material injury to itself or the frame, and another picture, or the like, cannot be placed in the frame without such injury as to disparage the aforesaid practice.

To this end, my invention consists in a permanent frame for advertising pictures and the like, so constructed that the picture must be placed therein as the frame is assembled, the parts of the frame being then so secured together that they cannot be separated without injury to the frame. The result is that the picture is not only held against abstraction without injury, but another picture, or the like, cannot be placed in the frame without injury to itself or the frame.

In the accompanying drawing, Figure 1 is a perspective view of my improved frame showing a card, which in practice would be an advertising picture, or the like, mounted in the frame; Figs. 2 and 3, perspective views of the side-rails and top or bottom rail; Fig. 4, a section taken on line 4 in Fig. 1; Fig. 5, a section taken on line 5 in Fig. 1 and illustrating the manner of assembling the parts; and Fig. 6, an enlarged broken

perspective view showing the way the rails are rabbeted and grooved.

The frame illustrated consists of the side-rails 10 and top and bottom rails 11, crossing each other as shown, to present ornamental corners 12. At the intersecting points of the rail they are rabbeted as shown at 13 to the depth, preferably, of one-half their thickness, so that when the frame is assembled the surfaces of the rails are flush with each other both at the front and back of the frame. In the inner edge of each rail is a picture-edge receiving-groove 14 terminating at the rabbet recesses 13. Each groove 14 is formed in the rail midway between the front and back of the latter and preferably by means of a circular-saw, each cut beginning and terminating in a curve corresponding to that of the saw and extending partway across the rabbet recesses.

In assembling the frame and contents, the top-rail is interlocked with the side-rails and the parts preferably glued together. The picture, or display-card, 15, which, of course, should be of dimensions to exactly fit the frame, is inserted at opposite ends of its top edge into the grooves 14 of the side-rails, at recesses 13, and slid along until its top edge enters the groove 14 of the top-rail. The bottom-rail is then passed at its groove 14 over the bottom edge of the picture, or the like, as shown in Fig. 5 and squeezed into locking engagement with the side-rails, at the same time being preferably glued thereto. The picture thus being permanently confined at its edges cannot be removed without injury thereto or to the frame. To replace the picture with another would involve so much trouble and necessary injury to the other, or the frame, that the likelihood of the frames being used in an unauthorized manner, as before stated, is at least greatly reduced. The frame may, of course, be rendered as ornate as desired, and when constructed as shown and described, the front and back, so to speak, may be equally ornate and the frame employed to display a picture, display-card, or the like, at each side.

What I claim as new and desire to secure by Letters Patent is—

1. A frame for a display-card, advertising picture, or the like, comprising a plurality of overlapping frame members, each of which is formed with recesses adapted to register with recesses in the members cross-

ing the same and each of which has a groove  
formed in its inner edge portion, which groove  
terminates in the recesses therein, whereby  
when the display-card, advertising picture,  
5 or the like is partially inserted in place in the  
said frame one of its edges may be tempo-  
rarily bent until the recesses in one of said  
members intermesh with the recesses of the  
member which it crosses, whereby all of the  
10 edges of said picture are confined within  
the grooves in said members and the picture  
is permanently secured in the frame.

2. In a frame for a display-card, adver-  
tising picture, or the like, the combination  
15 with side members, of bottom and top  
members, all of said members being pro-

vided with recesses adapted to receive an  
adhesive and to register with each other  
when the frame is assembled, of picture  
edge-receiving grooves formed on the inner 20  
sides of said members, such grooves termi-  
nating in the registering recesses therein,  
whereby a portion of the edges of the pic-  
ture adjacent its corners will be exposed to  
the adhesive applied to the registering re- 25  
cesses of the several frame members and the  
picture permanently secured in the frame.

FRANK W. WILLIAMS.

In presence of—

CHAS. E. GAYLORD,  
RALPH SCHAEFER.