

[54] APPARATUS FOR FORMING LENO SELVEDGE

3,698,441 10/1972 Mullekom..... 139/54

[75] Inventors: Vladimir Svaty; Lubomir Taticek, both of Liberec, Czechoslovakia

FOREIGN PATENTS OR APPLICATIONS

1,063,823 12/1953 France..... 139/50

[73] Assignee: Elitex, Zavody textilniho strojirenstvi, generalni reditelstvi, Liberec, Czechoslovakia

Primary Examiner—Henry S. Jaudon
Attorney, Agent, or Firm—Murray Schaffer

[22] Filed: Sept. 7, 1972

[21] Appl. No.: 286,860

[57] ABSTRACT

[30] Foreign Application Priority Data

Sept. 10, 1971 Czechoslovakia 6472-71

A method and apparatus for forming leno weaves in woven fabrics particularly on shuttleless weaving looms in which a shed is formed of warp threads. An additional thread is supplied in association with the warp thread. During formation of the shed the warp thread and the additional thread are given a relative circular motion whereby the threads are entwined about each other in a pure twist.

[52] U.S. Cl. 139/54

[51] Int. Cl. D03c 11/00

[58] Field of Search 139/17, 48, 50, 54

[56] References Cited

UNITED STATES PATENTS

1,515,595 11/1924 Friend..... 139/17

9 Claims, 6 Drawing Figures

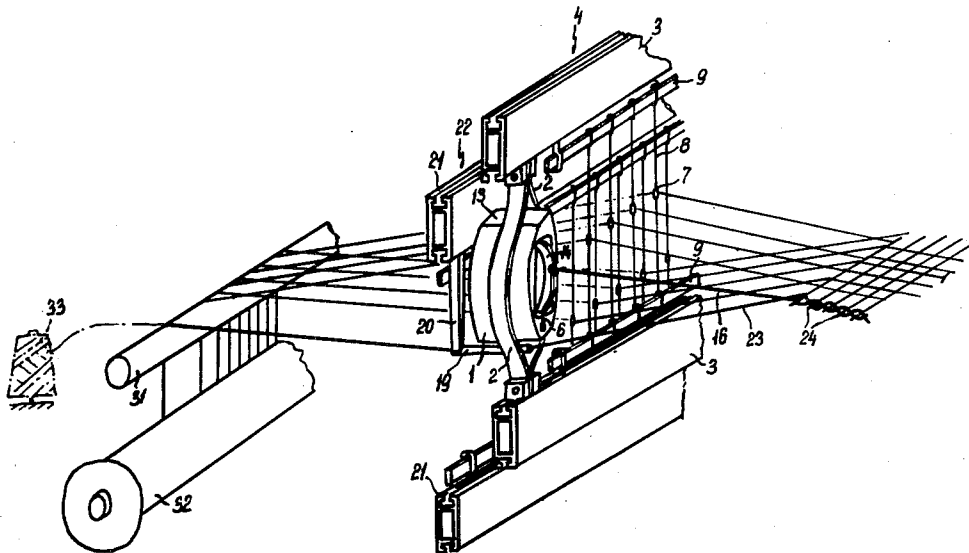

Fig. 1

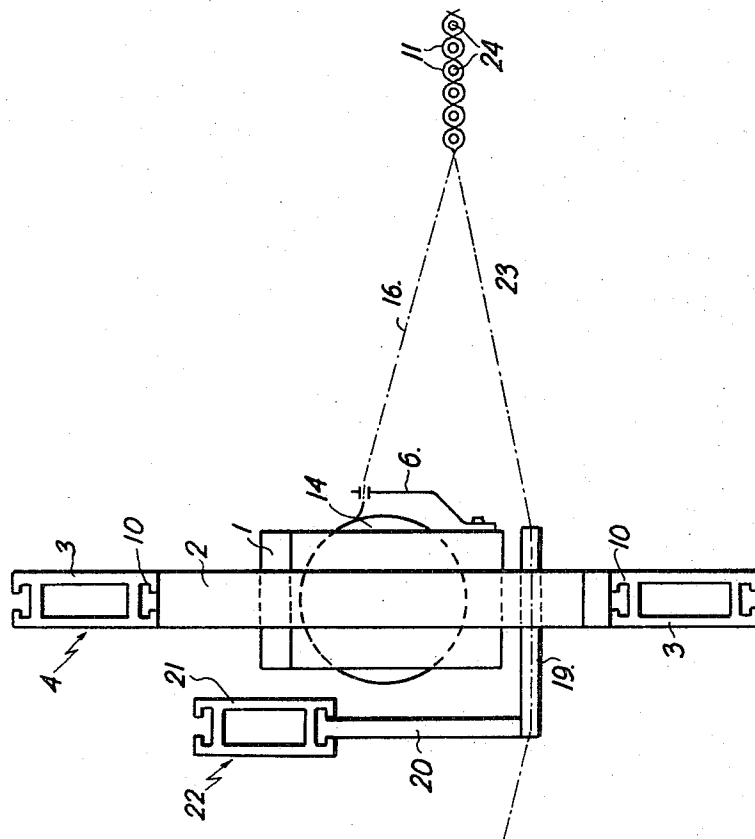

Fig. 2

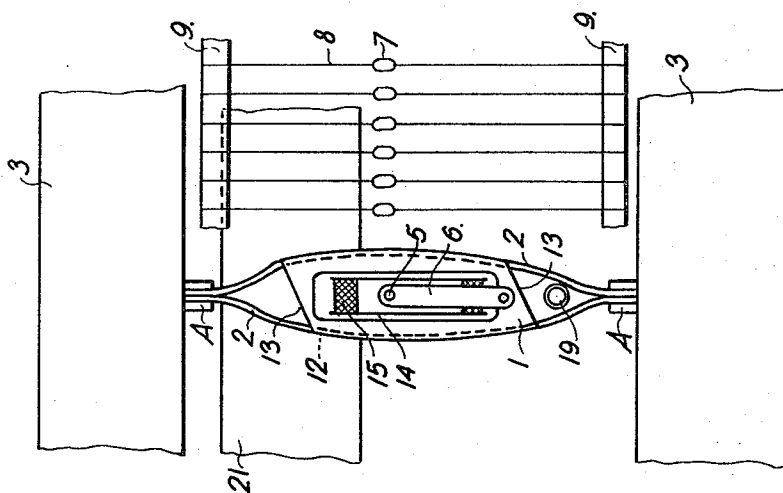

Fig. 3

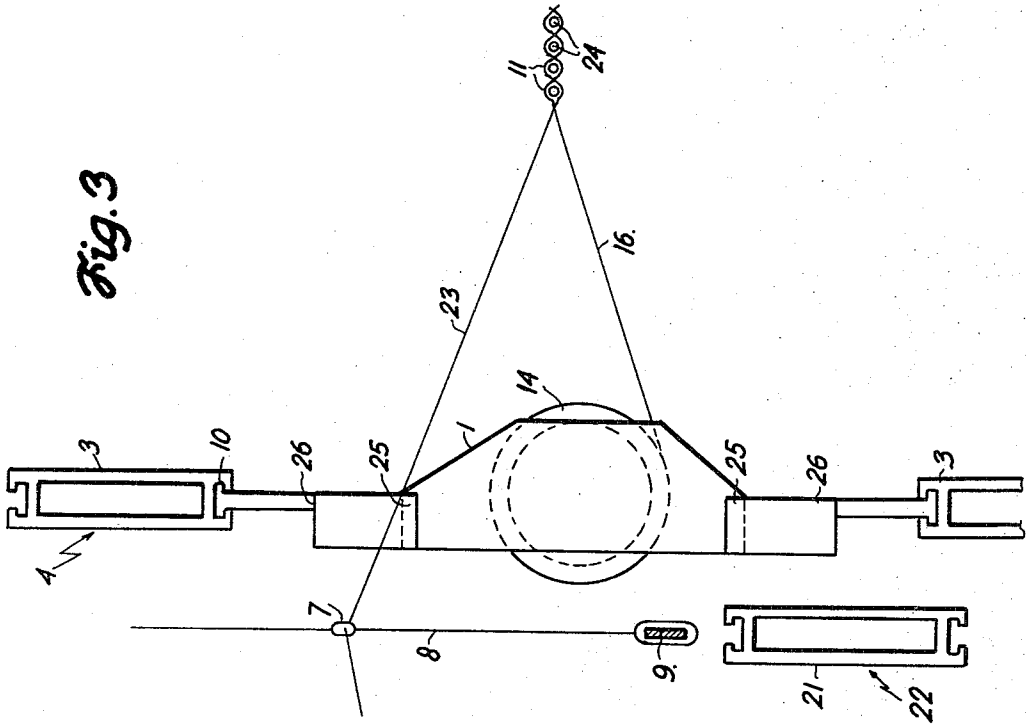
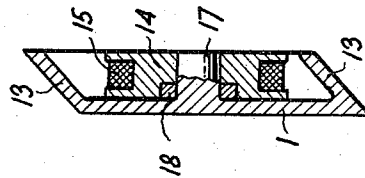
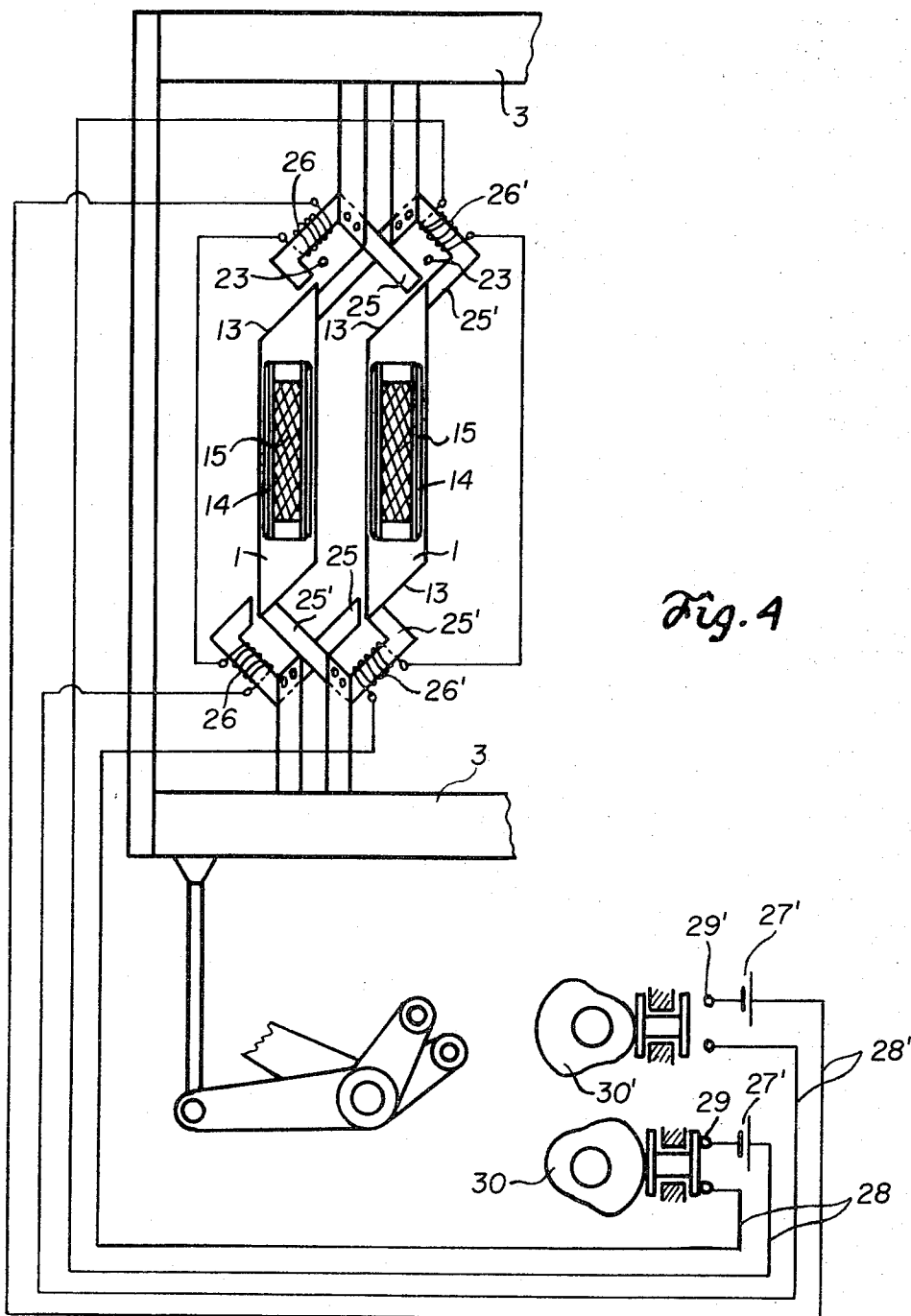
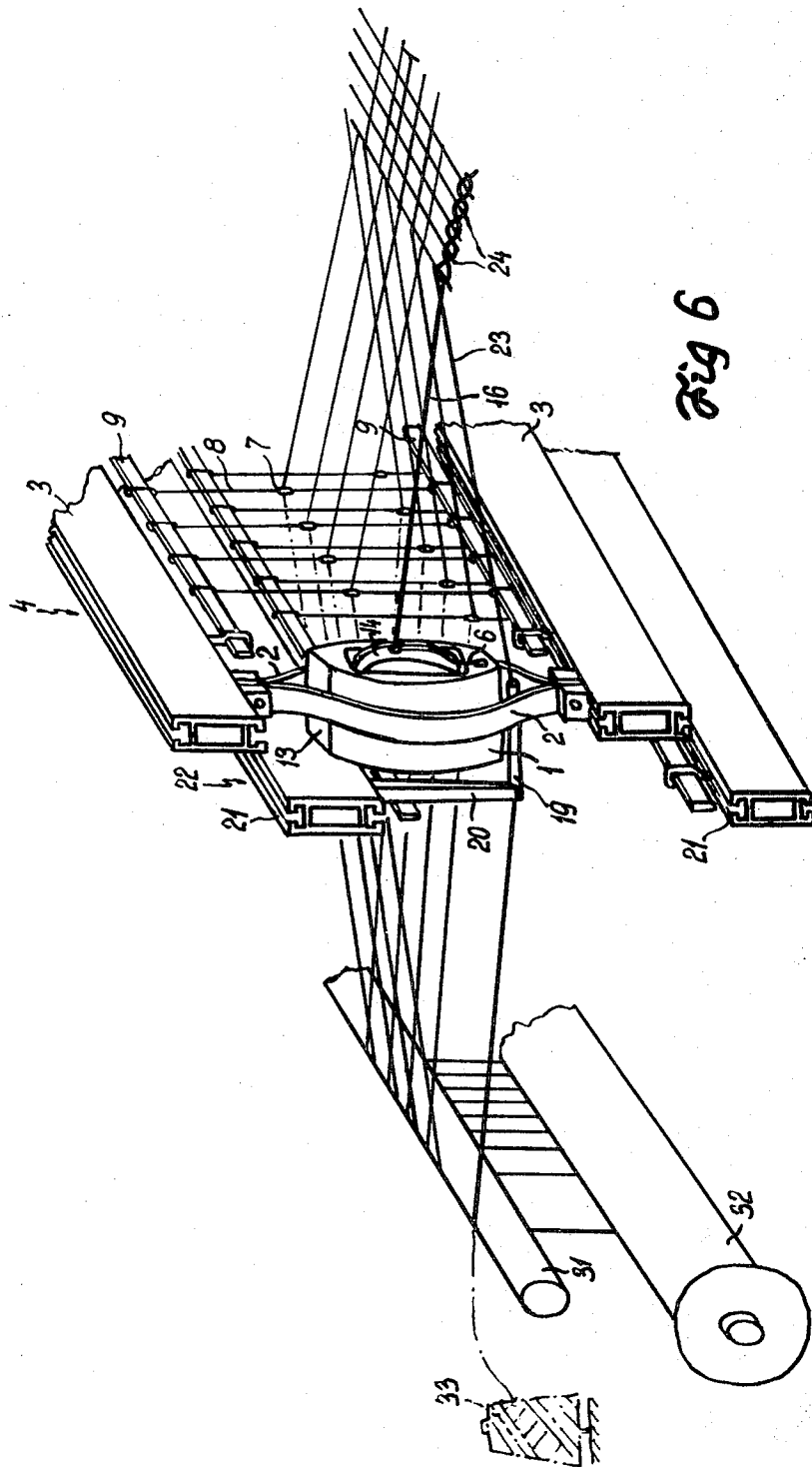

Fig. 5







APPARATUS FOR FORMING LENO SELVEDGE

BACKGROUND OF THE INVENTION

The present invention relates to a method of and an apparatus for forming leno weaves in fabrics, particularly in forming leno weaves on shuttleless weaving machines, employing warp threads and additional or added threads.

In weaving machines in which cut weft threads are used, it is necessary to reinforce the selvages of the formed fabrics by a leno weave in which two threads are mutually overcrossed to grip between them the free ends of weft threads. Various so-called rotary entwainers of leno threads have been developed. Generally, they comprise rotary carriers for the leno threads, which impart to them a rotary motion as they are unwound. The threads are moved in a circular or elliptical path, being wound upon each other to thus constitute a so-called true twist. The leno threads usually bind therebetween the ends of the weft threads which are woven in the fabric as they are mutually turned in an arc of about 180°. Such rotary entwainers require an independent drive and are complex in construction. As auxiliary equipment they are difficult to handle and place on the weaving machine. Furthermore, they are difficult to reset upon changing the width of the fabric being formed.

On the other hand, so called tilting entwainers, by which either the added leno threads or the warp threads are mutually overcrossed have also been used. These machines comprise a system of needles arranged on the heddle shafts to create a so called false twist. This equipment is moved by auxiliary mechanisms and is relatively easily displaceable on the machine. However, the leno weave formed thereby, generally has low strength, and the leno threads have a low degree of cohesion with the individual ends of the weft threads.

It is the object of the present invention to provide a method and apparatus for applying leno threads to a woven fabric which overcomes the difficulties of the prior art.

Another object of the present invention is to provide a method of forming leno weaves which exhibit good adhesion to the woven threads and good physical properties.

It is another object of the present invention to provide a method of weaving-in leno threads in a true twist.

It is further an object of the present invention to provide an apparatus for performing the weaving in of leno threads which does not require an independent drive, and which at the same time is easily displaceable on the weaving machine.

These objects as well as others together with numerous advantages will be seen from the following disclosure.

SUMMARY OF INVENTION

In accordance with the present invention, the method of forming fabrics having leno weaves from warp threads and additional or added threads, particularly on shuttleless weaving machines or looms, is provided. The method comprises the steps of forming a shed of at least a warp thread and supplying thereto an additional or added thread in association with the warp thread. Simultaneously, with the supply of the added

thread there is imparted a relative circular motion to the associated warp and added threads, which continues during the formation of the shed in order to entwine the warp and additive thread about each other.

Preferrably, the source of the added thread is contained on a movable carrier located adjacent the formation of the shed and is moved in the up and down reciprocating movement of the warp healds while the warp thread moves in a closed circular path about it.

Further, according to the present invention there is provided loom apparatus for forming fabrics with leno weaves from warp threads and added threads. The loom has a plurality of heald shafts and heddles arranged in cooperative relationships. The heald shafts are capable of movement in a conventional manner in opposite reverse directions to form a shed. One pair of heald shafts are arranged one behind the other and are provided with heddles each of which have an eyelet through which the warp thread is passed. A carrier for an additional or added thread is located on one of said heald shafts in a position corresponding to the eyelets of the heddles, of the other shaft in the associated pair. Means are provided for circularly moving the carrier and the heddle through which the warp thread is fed relative to each other, to cause the warp and added thread to entwine about each other.

In one embodiment the added thread carrier comprises a floating sleeve secured between a pair of stretched flexible tapes, and the warp thread is passed through a tubular guide. The guide is adapted to be moved between the surface of the carrier and the tapes in a circular path. In a second embodiment the carrier is supported between a pair of magnets which shuttle the carrier in a reciprocating movement while the warp thread slides about the carrier.

Preferrably, the carrier and its associated supports are mounted on the healds of the warp system of the first of a pair forming the shed and the warp passes from the rear heddles through the supports.

It is to be understood that in the foregoing reference to various parts of a loom are made. These references are made with the conventional meanings and functions in mind and such items as the heald shafts, heddles, warp systems and other elements of the apparatus are the same as those well known in the field of shuttleless looms or weaving machines.

Full details, features and advantages of the present invention are set forth more specifically in the following specification which is to be taken in conjunction with the accompanying drawings. It is being clearly understood that conventional shuttleless weaving machines, properly modified to contain or include the elements of the apparatus of this invention, are employed to carry out the method of this invention.

BRIEF DESCRIPTION OF DRAWINGS

In the drawings:

FIG. 1 illustrates the present invention in which a carrier for a supply of additional or added thread, in the form of a floating sleeve is located between two oppositely mounted heald rods of one heald shaft with a diagrammatic representation of the arrangement of a tubular guide for the warp thread which is fastened on the heald rod of the following heddle shaft;

FIG. 2 shows a front view of the device seen in FIG. 1;

FIG. 3 shows a lateral view of another embodiment of the invention in which the carrier is disposed between the poles of a plurality of electromagnets fastened on the heald rods of the heald shaft;

FIG. 4 is a front view of the device seen in FIG. 3; a simplified electric control circuit therefor;

FIG. 5 is a longitudinal sectional view through the carrier and showing the position of the supply of additional thread and a magnetic braking ring in the bobbin of the supply; and

FIG. 6 is an isometric sketch showing the weaving system.

It will be observed that the drawings show only those parts of the weaving machine necessary for an understanding of the present invention. The parts omitted are well known and conventional and are structural and functional in the normal and conventional manner. Consequently, to describe such well known equipment would only unnecessarily lengthen this disclosure.

DESCRIPTION OF THE INVENTION

Referring now more specifically to FIG. 1 and FIG. 2, there is illustrated therein an embodiment of the apparatus in accordance with the present invention, comprising an elongated carrier for additional or added thread in the form of a floating sleeve 1 movably secured by suitable means such as at least two gripping stretched straps or tapes 2 between two oppositely disposed heald rods 3 of the conventional heald shaft 4. A thread guide 6 having an eyelet 5 is fixedly mounted on the sleeve 1, and located at such a position that the center of the sleeve and the eyelet 5 of the guide 6 corresponds to the position or horizontal level of the eyelets 7 of the neighboring heddle wires 8 fixed on the heddles 9 of the same heald shaft 4.

The heald rods 3 are provided with a longitudinal key groove 10 which receives the conforming ends of a clamping means A holding the sleeve 1.

The gripping tapes 2 are made of suitable elastic and/or flexible material such as plastic, rubber, leather, etc. and are resiliently suspended, so that they may be distended by the up and down movement of the carrier 1 which floats between the tapes 2. The entire assembly of tapes and carrier sleeves 1 are movable and displaceable in grooves 10 along the entire length of heald shaft 4 according to the width of the fabric 11 to be woven.

The floating carrier sleeve 1 is secured between the gripping tapes 2 so that they are firmly seated but can be slid relatively to it and be separable from it. This can be accomplished by providing the floating sleeve 1, for example, on its outer frontal surface with a shallow longitudinal groove 12 which corresponds in depth and width to the size of the gripping tapes 2. This provides a longitudinal key way in which the tapes fit and are permitted vertical movement but not lateral movement. The two ends of the floating sleeve 1 are provided with parallel contact surfaces 13 extending in an oblique direction to its frontal surfaces. As seen in FIG. 5, the floating sleeve 1 is hollow and at least open on one side. A supply means such as a metal bobbin 14 having a winding 15 on which the additional or added thread 16 is wound, is mounted within the hollow space. The bobbin 14 is supported on a pin 17 by a magnetic ring 18, which constitutes the braking means for the bobbin. The magnetic ring exerts a drag on the bobbin preventing the thread from being pulled off be-

yond the length needed, thus preventing its unravelling, and keeping the thread under proper tension.

A tubular guide 19 carrying a warp thread extends between the tapes 2 beneath the floating sleeve 1 toward the forming shed and forming fabric. The guide 19 is supported by means of a resilient carrier beam 20 disposed on one of the heald rods 21 of the following or next succeeding heald shaft 22 of the weaving machine. The tubular guide 19 penetrates the space between the gripping tapes 2 and the lower oblique surface of the floating sleeve 1 when the apparatus is at rest position. A warp thread 23 is guided through the tubular guide 19 and is normally withdrawn from a warp beam or from a stationary supply (neither of which are shown) mounted on the weaving machine.

Suitable means for synchronizing the movement of the associated healds, etc. to provide the shed formation of threads, and the operation of the floating carrier sleeve is provided by the use of conventional apparatus, which is not shown here. It will be seen that only a pair of heald shafts 4 and 22 are shown. The apparatus can be arranged with pluralities of pairs of heald shafts, dependent upon the number of warps in the shed formation.

The apparatus shown in FIGS. 1 and 2 operates as follows:

The adjacent separate heald shafts 4 and 22, arranged behind each other, are given the usual opposite motion, whereby the warp threads, controlled by them, form a weaving shed in the known manner. During shed forming movement, the floating carrier sleeve 1 carried in tapes 2 moves up and down carrying the additional or added thread 16 with it. Simultaneously, the tubular guide 19 which is fastened on the other heald shaft 22 moves oppositely thereto in a shifted phase relative to each other. Upon the mutual but relative movement of the floating carrier sleeve 1 and the tubular guide 19, the guide moves upwards from the position as shown in FIG. 2, while the floating sleeve 1 sinks. This movement proceeds until the guide 19 contacts lower oblique contact surface 13 of the sleeve 1. As the sleeve 1 moves downward and the guide 19 moves further upward the guide 19 slides over the angular contact surface 13 between the frontal surface of the sleeve 1 and the gripping tape 2, thus deflecting and spreading the gripping tape 2 apart so that the tubular guide 19 can slide further upward in the advancing slot that is thus formed. The guide 19 moves along the frontal face of the sleeve 1 until it reaches the opposite end 13 of the carrier sleeve 1. At that moment, the direction of movement of both the carrier sleeve 1 as well as the tubular guide 19, is changed by the appropriate control mechanism synchronized with the shed rhythm, whereupon tubular guide 19 now contacts the upper contact surface 13 and slides down passing between the other frontal surface of the floating carrier sleeve 1 and the tape 2. The guide 19 moves downwardly until it returns into its original position below the sleeve 1. This relative movement of the tubular guide 19 and floating sleeve 1 is repeated in synchronism as the rhythmic reciprocation of the shed changes, to provide a relative circular movement of either the warp thread 23 about the additional or added thread 16, or vice versa.

With the operation described the additional or added thread 16 is withdrawn from bobbin 14 located inside floating carrier sleeve 1 and entwined in a pure twist by the warp thread 23. During the entwining, the ends of

woven in weft threads 24 are gripped by the separate turns of those additional or added threads and warp threads, thus reinforcing the selvages of the fabric 11.

Another embodiment is shown in FIGS. 3 and 4 in which the sleeve 1 may be mounted freely between a pair of electromagnetic supports rather than between the flexible tapes. In the embodiment of the apparatus of this invention, as illustrated in FIGS. 3 and 4, at least one or more sleeves 1 are arranged side to side between pole shoes 25, 25' of each of electromagnets 26, 26'. The poles of the magnets 26 and 26' at one end of the carrier 1 are directed always at the oblique surface of the carrier and one frontal face respectively, while those poles at the opposite end are directed in reverse manner at the oblique surface and the other frontal surface respectively. The electromagnets 26 and 26' are provided with supply circuits designated by numeral 27 connected to a suitable source of power 28 such as the line source and with one or more switches such as those designated at 29 driven by a cam mechanism 30. Cam mechanism 30 is linked through conventional means from a main shaft of the weaving machine in order to accomplish synchronous switching of the individual electromagnets 26 and 26' with the shedding rhythm of the weaving machine.

No special guide such as guide 19 is needed for guiding the warp thread 23 of the embodiment shown in FIG. 3, and instead the usual heddle means 8 having a guiding eyelet 7 is employed to feed the warp thread 23.

The operation of the arrangement of the apparatus according to illustration FIGS. 3 and 4 is as follows:

When the healds 8 with the warp threads 23 are in their upper position (FIG. 3) a switch closes the circuit of electromagnets 26' and whereon the floating carrier sleeves 1 bear against the inner pole shoes 25' and gaps are formed between the outer pole shoes 25 of the electromagnets 26 and the contact outer surfaces 13. The warp threads 23 is thus permitted to slide through these gaps riding on the outer surface of floating sleeves 1, as a result of the downward reciprocation of the healds. As soon as the warp threads 23 are reversed in their direction into an upward reciprocation the electromagnets 26 are energized and new gaps are formed between the outer pole shoes 25 and the outer surfaces of floating sleeves 1, permitting the warp thread 23 to slide upwardly.

Because the tapered contact surfaces 13 of floating carrier sleeve 1 determines the direction of circulation of warp threads 23 about floating sleeves 1, the mere switching over of electromagnets 26 and 26' permits the circular movement of the warp thread simultaneous with its feed, without any auxiliary means such as guide 19. Since a relative circular movement is provided true twist is formed between the warp threads 23 and the additive threads 16 which, as in the first embodiment, is suitable for holding the ends of the inserted weft threads 24.

It is to be appreciated that what has been provided in both embodiments is the concept of relatively moving the sleeve 1 and guide 19 so that the warp thread is carried in a circular path about the added thread, or vice versa, so that the added thread and the warp thread are entwined in a perfect true twist. It is to be understood that the structure and operation of the apparatus of the present invention may be accomplished in a variety of

other ways. For example, the floating carrier sleeve 1 can be arranged in a stationary manner with respect to the weaving machine, and the guide 19 carrying the warp thread 23 made to move about the sleeve on a continuous circular path. In another arrangement, the warp thread 23 can be held stationary and the floating sleeve 1 can be moved around it while carrying the additional or added thread 16. The particular arrangement and operation employed, however, depends on the type of weaving machine to be used. The modification of the design of the supports for the various means such as the floating carrier sleeve, guide means and other elements may take many forms.

Numerous modifications of this invention have been shown and suggested others can be made without departing from the spirit hereof. It is to be understood that the method and apparatus of this invention is not to be limited to the disclosed embodiments thereof except as defined in the appended claims.

What is claimed is:

1. Loom apparatus for forming selvages with leno weaves from warp threads and added threads, said loom having a plurality of heald shafts, said heald shafts being capable of movement in opposite reverse directions to form a shed, at least one pair of heald shafts in which one shaft is located behind the other, a plurality of heddles located on each of said heald shafts, each of said heddles having an eyelet through which a warp thread is fed, a carrier located on one of said heald shafts in position corresponding to an eyelet of a certain of said heddles of the other shaft, supply means located on said carrier for supplying added thread and means for circularly moving the carrier and the heddle through which said warp thread is fed relative to each other to entwine said warp and said added thread about each other.

2. The apparatus according to claim 1 wherein the carrier comprises a sleeve moveably secured between a pair of tapes fastened at each end on oppositely mounted heald rods of said one heald shaft and said other heald shaft is provided at said eyelet with a tubular guide through which said warp is fed, said tubular guide extending into contact with the surface of said sleeve.

3. Apparatus according to claim 2 wherein the outer surface of said sleeve is provided with longitudinal grooves in which said gripping tapes are disposed.

4. Apparatus according to claim 3 wherein an adjacent pair of heald shafts are each provided with a carrier mounted between said pole shoes of an electromagnet.

5. Apparatus according to claim 2 wherein the gripping tapes are made of flexible material.

6. The apparatus according to claim 1 wherein the carrier is mounted between a plurality of electromagnets located in said heald shaft, and includes means for alternately activating said magnets in synchronism with the shedding rhythm to attract said carrier in a reciprocating motion to form gaps between the carrier and the magnets to permit passage of said warp thread in a circular path thereabout.

7. The apparatus according to claim 1 wherein the ends of the carrier are provided with contact surfaces for directing said warp in a unidirectional circular path.

8. The apparatus according to claim 1 wherein the carrier is a metal bobbin provided with a magnetic braking ring for braking the same.

9. The apparatus according to claim 1 wherein the carrier includes a stationary guide for withdrawing the additive thread.

* * * * *