

[54] **WHEEL CHAIR LIFT**

[72] Inventor: **Jay L. Glasser**, 2305 Martha Ave., N.E., Canton, Ohio 44705

[22] Filed: **Dec. 23, 1969**

[21] Appl. No.: **887,583**

[52] U.S. Cl. **187/25, 187/1, 187/8.52**

[51] Int. Cl. **B66b 11/04**

[58] Field of Search 187/9, 24, 25, 8.52; 214/75

[56] **References Cited**

UNITED STATES PATENTS

2,733,825	2/1956	Evans	187/8.52
3,229,788	1/1966	Booth	187/10
3,233,767	2/1966	Goodacre	187/8.52
3,396,822	8/1968	Guilbert	187/58
3,516,559	6/1970	Walter	187/9

3,521,775 7/1970 Vermette.....187/9

Primary Examiner—Harvey C. Hornsby
Attorney—Stowell & Stowell

[57] **ABSTRACT**

A vertical wheelchair lift including a vertically movable horizontal platform having edge wheel curbs to prevent wheelchair dislodgement therefrom one of the curbs constituting a loading and unloading ramp selectively adjustable to a lowered wheelchair loading and unloading position and a raised curb position, and means on said lift selectively operable for raising and lowering the ramp, and for vertical movement of the platform. Operating control means are so located as preferably to be operable by a wheelchair occupant, but readily accessible for external use. The lift is ideally suited for use in conjunction with structures having entrance or other steps between levels which are not normally negotiable solely by a wheelchair user.

10 Claims, 8 Drawing Figures

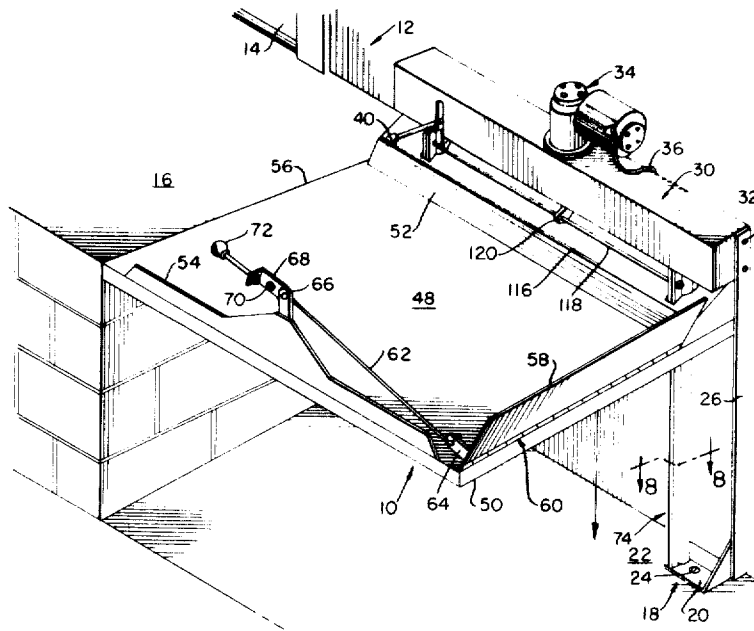

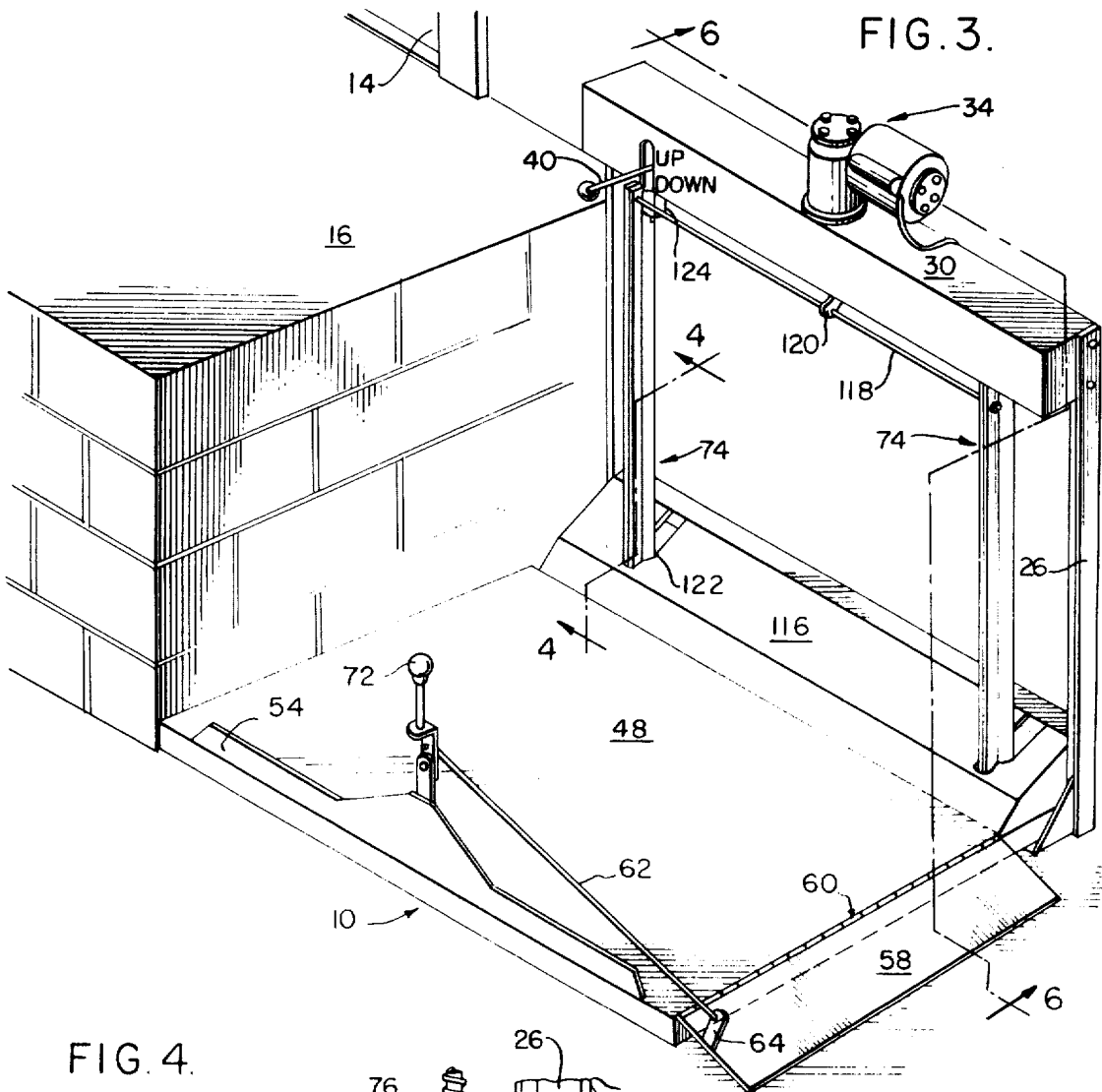

FIG. 4.

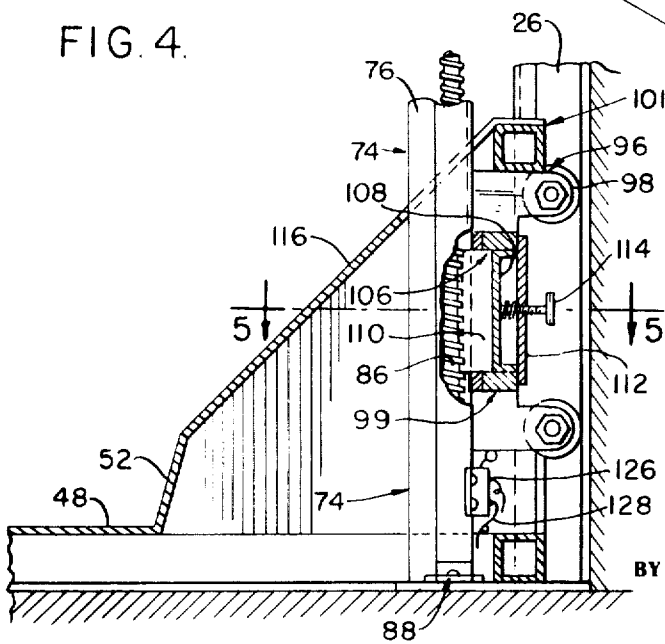
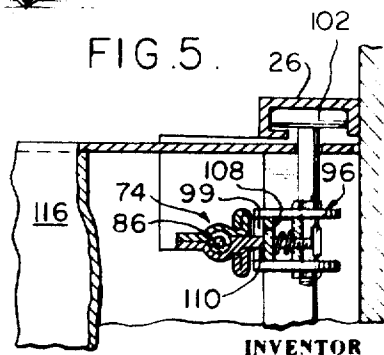

FIG. 5.



INVENTOR
Jay L. Glasser

Stowell & Stowell

ATTORNEYS

FIG. 6.

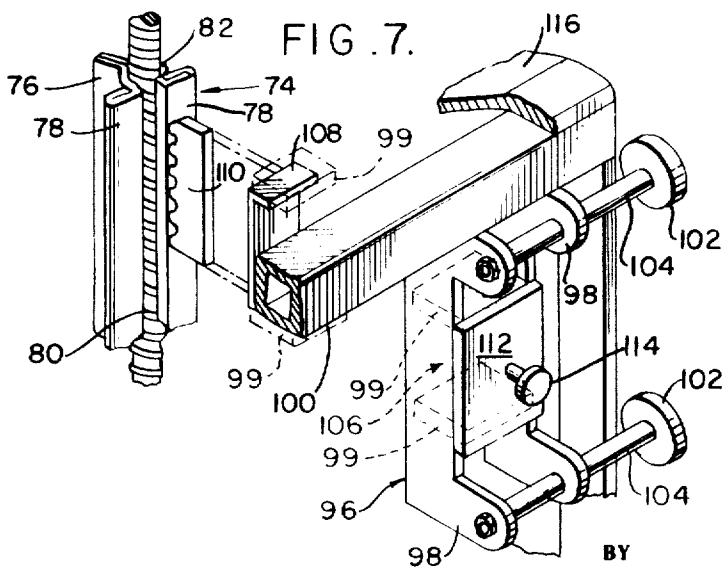
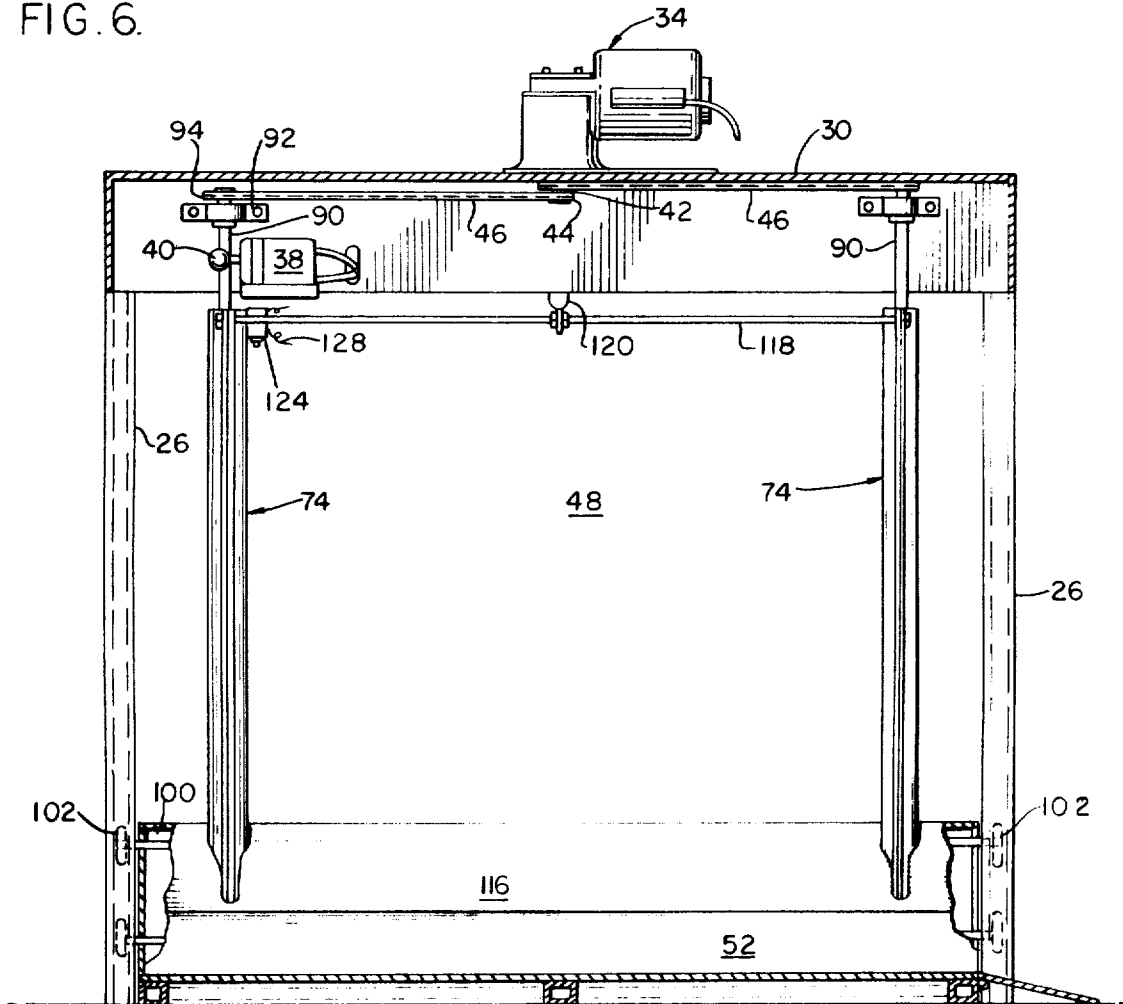
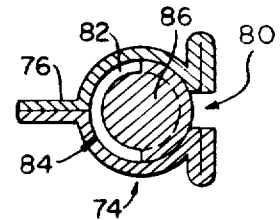

FIG. 8.



INVENTOR
Jay L. Glasser

Stowell & Stowell

ATTORNEYS

WHEEL CHAIR LIFT

BACKGROUND OF THE INVENTION

Difficulties are encountered by users of wheelchairs in negotiating a change of levels, especially where interconnected by stairs or where inclined ramps are not incorporated in structures or are not practically feasible. Such difficulties are aggravated in situations where assistance is not reasonably available, or even if ramps are provided they are too steep for unaided traverse by a wheelchair user. Such circumstances frequently exist in homes where even though floor design facilitates wheelchair use, entrance or departure is difficult or not possible in the absence of assistance. Heretofore apparatus of simple and inexpensive construction has not been available for use in such situations, and particularly an apparatus which is easily useable by an unaided wheelchair occupant.

SUMMARY OF THE INVENTION

The present invention is a wheelchair lift for vertically moving a wheelchair, and occupant, between vertically spaced levels, and wherein the lift can be easily operated by the occupant, or another, and eliminates the necessity of manual assistance. The lift includes a horizontal platform and vertical movement drive means with actuating controls, all of which are incorporated in the lift structure, which is of a compact and simple construction lending itself to ready and inexpensive installation and use. The platform is provided with curbs at its edges in the nature of upstanding plates, and one of which is hinged for rotation from a raised wheelchair restraining position to a downwardly and outwardly inclined position to serve as a loading and unloading ramp. Ramp and lift controls are placed for convenient operation by a wheelchair occupant.

Additional objects and advantages of the invention will be apparent from the following detailed description of a preferred embodiment thereof when taken together with the accompanying drawings in which:

FIG. 1 is a perspective view of a wheelchair lift in accordance with the invention as installed at a building entrance and in elevated position;

FIG. 2 is a top plan view of the wheelchair lift shown in FIG. 1;

FIG. 3 is a view similar to FIG. 1 with the wheelchair lift in a lowered position, and with a loading and unloading ramp in operable position;

FIG. 4 is an enlarged, fragmentary, sectional view taken on line 4-4 of FIG. 3;

FIG. 5 is a fragmentary sectional view of a corner portion of the wheelchair lift taken generally on line 5-5 of FIG. 4;

FIG. 6 is an elevational view taken generally on line 6-6 of FIG. 3;

FIG. 7 is an exploded enlarged fragmentary perspective view, partly in section, of support, drive and guide means for a wheelchair lift platform; and

FIG. 8 is a sectional view taken on line 8-8 of FIG. 1, showing details of the elevating mechanism.

The chairwheel lift 10 constituting the invention is illustrated and described as associated with a building 12 having a door 14 and an entrance stoop or porch 16 which can be of a type comprising a single step or having plural steps. Obviously the invention can be used for different structures and locations. The lift includes spaced vertical support members generally designated 18 having foot portions 20 attached to a support surface 22 such as by bolts 24. The members include vertical inwardly opening partially closed channel beams 26; which can constitute portions of a structural frame and are adapted for securement to a wall 28 of building 12 in an appropriate manner.

An open bottom box structure 30 is interconnected between the upper ends of beams 26, as by bolts 32, in the nature of an open bottom header. An electric drive motor and transmission unit 34 are mounted on the box, the motor being appropriately connected by leads 36 to a suitable power

source, not shown. The motor is reversible and operated through a connected switch 38 by handle 40. The switch has, as indicated in FIGS. 1 and 3, up down down motor energizing positions which serve to actuate the motor in opposite drive directions to raise or lower the lift as desired. Shaft 42 of the transmission of unit 34 has sprocket wheels 44 secured thereon which are in driving engagement with sprocket chains 46. These chains, as will appear hereinafter, serve to actuate the elevator mechanism for the lift.

A wheelchair support platform 48 is mounted on a frame, Platform 48 is flat and of any desired shape and size. Edge walls 52 and 54 extend above the upper surface of the platform along two edges thereof and, as shown, can be slanted and serve as wheel curbs to prevent a wheelchair mounted on the platform from dislodgement. A third edge 56 is adapted for juxtaposition to the surface of porch 16 (FIG. 1) to permit movement of the wheelchair from and to the platform or porch as desired. A ramp 58 is hingedly secured to platform 48 at its fourth edge 60, at the end opposite edge 56. A control rod 62 is connected at one end to lug or ear 64 attached to ramp 58 in proximity to an end thereof. A tab 66 is secured on wall 54 and pivotally mounts a lever 68 to which the free end 70 of rod 62 is connected. A handle 72 is attached to the end of lever 68 and is operable through the rod, upon actuation, to raise ramp 58 to the position shown in FIG. 1 for wheelchair confinement on the platform, or to lower the ramp to the position shown in FIG. 3 for loading and unloading a wheelchair. The handle is readily accessible from positions on or off the platform.

The platform elevating mechanism includes spaced vertical uprights 74 generally comprising a T-shape configuration housing which can be of extruded aluminum for example with a stiffening and strengthening leg portion 76 and separated head portions 78 forming therebetween a slot or an opening 80 facing away from the platform. A generally cylindrical shaped bore 82 is formed interiorly of the upright and constitutes the actual housing 84 for a worm drive screw 86 rotatably confined therein. The screw can preferably be triple threaded to facilitate operation, including reversal of platform movement. The lower ends of screws 86 are journaled in thrust bearings 88 mounted, for example, on feet 20. The upper ends 90 of the screws are rotatably journaled in bearings 92 and sprocket wheels 94 are secured on the free ends and in engagement with chains 46 for driving the screws.

To impart movement to the platform 48 from screws 86 a traveller 96 in the nature of a bifurcated or C-shaped bracket, having side plates 98 and upper and lower face plates 99, engages under and is preferably attached to beam 100, which is a portion of a frame and structure 101 attached to the platform 48 and frame 50. Guide and support wheels 102 are mounted on shafts 104 welded to ears on the side plates 98 (FIG. 7) and engage in an interior track formed in channel beams 26 (FIGS. 4 and 5) in rolling engagement therewith. The inner surfaces and configuration of the beams prevents dislodgement during movement of the wheels. A groove or slot 106 formed between the side plates 98 and face plates 99 slidably receives supports, and retains a channel member 108 having secured thereto as by welding a toothed blade 110 which extends through opening 80 FIGS. 7 and 8, the teeth of which are in engagement in the threads of screws 86. A back plate 112 is secured to traveller 96 and having a screw threaded hole therethrough in which is threadedly engaged a release handle 114, the inner end of which engages with channel 108. The release handle is operable to engage or disengage the toothed blades 110 and the threads of screws 86.

As will be apparent, upon rotation of screws 86 the travellers 96 and platform supported thereby will be elevated or lowered as desired.

The structure is such that the channel 108 and blade 110 can, as a unit, be removed from bracket 96 for replacement when it becomes worn, and adjustability by handle 114 permits compensation for wear to insure positive lift operation.

Formed as an extension of edge wall 52 is a hood portion 116 which covers the travellers 96 and associated mechanism and also constitutes a structural component of a frame 101. A brace 118 extends between the leg portions 76 and is further supported and secured by a horn as at 120. Openings 122 are provided in the hood portion for passage therethrough of uprights 74 during travel of the platform.

Upper and lower limit switches 124, 126 respectively are attached to uprights 74 in the path of travellers 96 and serve to stop movement of the platform at the desired upper and lower positions or levels, being operatively electrically connected with the motor by leads as at 128. Following stoppage reactivation occurs through manipulation of switch 38.

Operation of the invention will be readily apparent from the foregoing, and further description is unnecessary. Manifestly minor changes and modifications can be made in the shown and described embodiment without departing from the spirit and scope of the invention as defined in and limited solely by the appended claims.

What is claimed is:

1. A wheel chair lift adapted for association with a multiple level structure comprising:

- A. a vertical frame means including a pair of spaced vertical posts;
- B. a horizontal platform;
- C. a cantilever platform support means connected at spaced positions to one edge of said platform and vertically movably engaged with said vertical posts of said vertical frame means;
- D. means operable for selectively raising and lowering said platform support means and said platform therewith, and a wheelchair and occupant thereon to and between different levels;
- E. edge curbs along sides of said platform to prevent wheel chair displacement therefrom;
 - i. one said curb being pivotally attached to one side of said platform and movable into a raised wheel chair restraining position and lowered inclined wheel chair loading and unloading ramp position; and
- F. manual control operating means on said platform connected to said pivotally attached curb for selective positioning thereof;
 - i. said operating means comprising a lever pivotally connected at one end to said curb, and a handle pivotally mounted on said platform intermediate opposite ends thereof and connected to the opposite end of said lever, said handle being positioned for ready access to a wheel chair occupant on said platform and upon pivotal actuation raising or lowering said curb.

2. A wheelchair as claimed in claim 1, said curbs being fixed along two sides of said platform, said pivotally attached curb being attached to a third side and a remaining side being unimpeded and adapted for juxtaposition at a level for wheelchair

loading and unloading and intermediate the levels being adapted to proximate a structure portion for wheelchair confinement on said platform.

3. In a wheel chair lift adapted for association with a multiple level structure as claimed in Claim 13, said raising and lowering means comprising: a vertically disposed screw rotatably mounted on said platform, a toothed blade attached to said platform and in operable engagement with said screw, and means to rotate said screw selectively in opposite rotational directions whereby the engagement therewith of said blade will elevate or lower said platform and a wheel chair supported on said platform.

4. In a wheelchair lift as claimed in claim 3, a vertical frame secured to said platform, an open bracket secured to said frame, means defining a support guideway in said bracket, said toothed blade being slidably engaged in and removable from said guideway, and means operatively associated with said bracket and said blade for adjustable engagement between said blade and said screw.

5. In a wheelchair lift as claimed in claim 4, a vertical housing containing said screw, a rectilinear slot through said casing, said toothed blade extending through said slot for engagement with said screw.

6. In a wheelchair lift as claimed in claim 5, a structural member transversely slidably and removably disposed in said guideway, said blade being vertically affixed to said structural member, a plate secured to said bracket and having a threaded bore therethrough, a screw engaging in said bore and having an end thereof engageable with said structural member and adapted upon rotation to adjustably engage said blade and said screw by movement of said member in said guideway.

7. In a wheelchair lift as claimed in claim 4, including vertical partially rectilinearly closed channel members disposed transversely of said bracket and interiorly thereof defining trackways, wheels rotatably mounted on said bracket and operatively engaged in said trackways, said wheels and trackways coacting to form a rolling horizontal support for said platform.

8. In a wheelchair lift as claimed in claim 3, a reversible electric motor, a transmission attached to said motor, and drive means operatively interconnecting said transmission and said screw.

9. In a wheelchair lift as claimed in claim 8, including control means operable for selective reverse actuation of said motor to raise or lower said platform, said control means being positioned for access to a wheelchair occupant on said platform.

10. In a wheelchair lift as claimed in claim 11, upper and lower limit switches interposed in the path of travel of said platform for predetermined upper and lower limits of travel thereof, said switches being operatively connected to said motor.

* * * * *

55

60

65

70

75