

[54] **TOILET FLUSH TANK APPARATUS**  
 [75] Inventor: **George Koket, Erie, Pa.**  
 [73] Assignee: **Hoover Ball and Bearing Company, Saline, Mich.**  
 [22] Filed: **May 31, 1974**  
 [21] Appl. No.: **475,299**

3,370,820 2/1968 Liss et al..... 248/230 X  
 3,763,501 10/1973 Minardi, Jr..... 4/67 A

**FOREIGN PATENTS OR APPLICATIONS**

184,654 8/1922 United Kingdom..... 248/79

*Primary Examiner*—Henry K. Artis  
*Attorney, Agent, or Firm*—Olsen and Stephenson

[52] **U.S. Cl.**..... 4/1; 4/57 R; 248/75; 248/230  
 [51] **Int. Cl.<sup>2</sup>**..... **A47K 17/00**  
 [58] **Field of Search** ..... 4/67 R, 67 A, 57 R, 57 P, 4/110, 1; 248/75, 79, 230

[57] **ABSTRACT**

An improved overflow tube in a toilet tank for use in conjunction with a flexible refill tube that extends from a ball cock mounted in the toilet tank. The improved overflow tube is a plastic extrudate that has two radially inwardly extending flanges into which the end of the flexible refill tube can be fitted so as to obviate the need for a conventional spring or plastic clip to hold the end of the refill tube in place within the overflow tube.

[56] **References Cited**  
**UNITED STATES PATENTS**  
 2,743,459 5/1956 Schmidt et al..... 4/57 R  
 3,251,069 5/1966 Clark ..... 4/110  
 3,319,913 5/1967 Schoepe et al. .... 248/75

**2 Claims, 4 Drawing Figures**

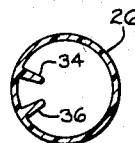
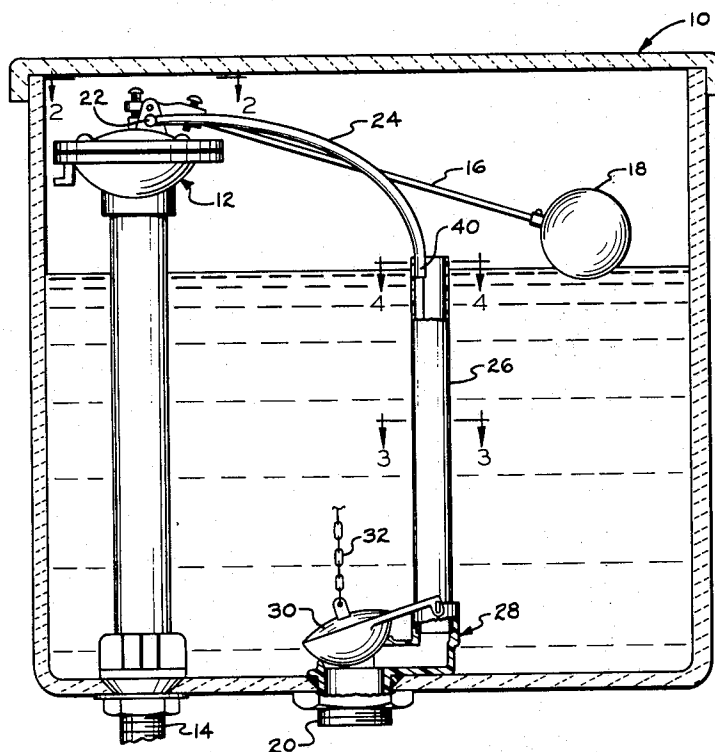

FIG. 1

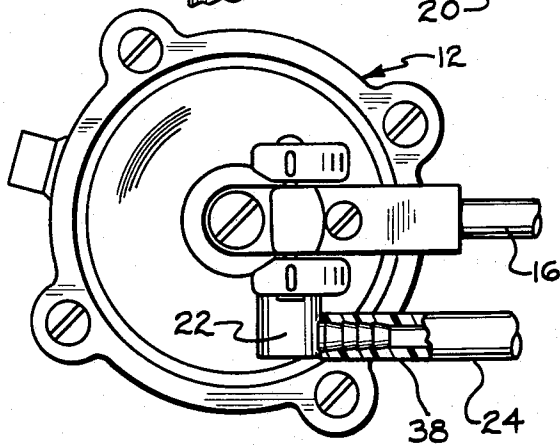
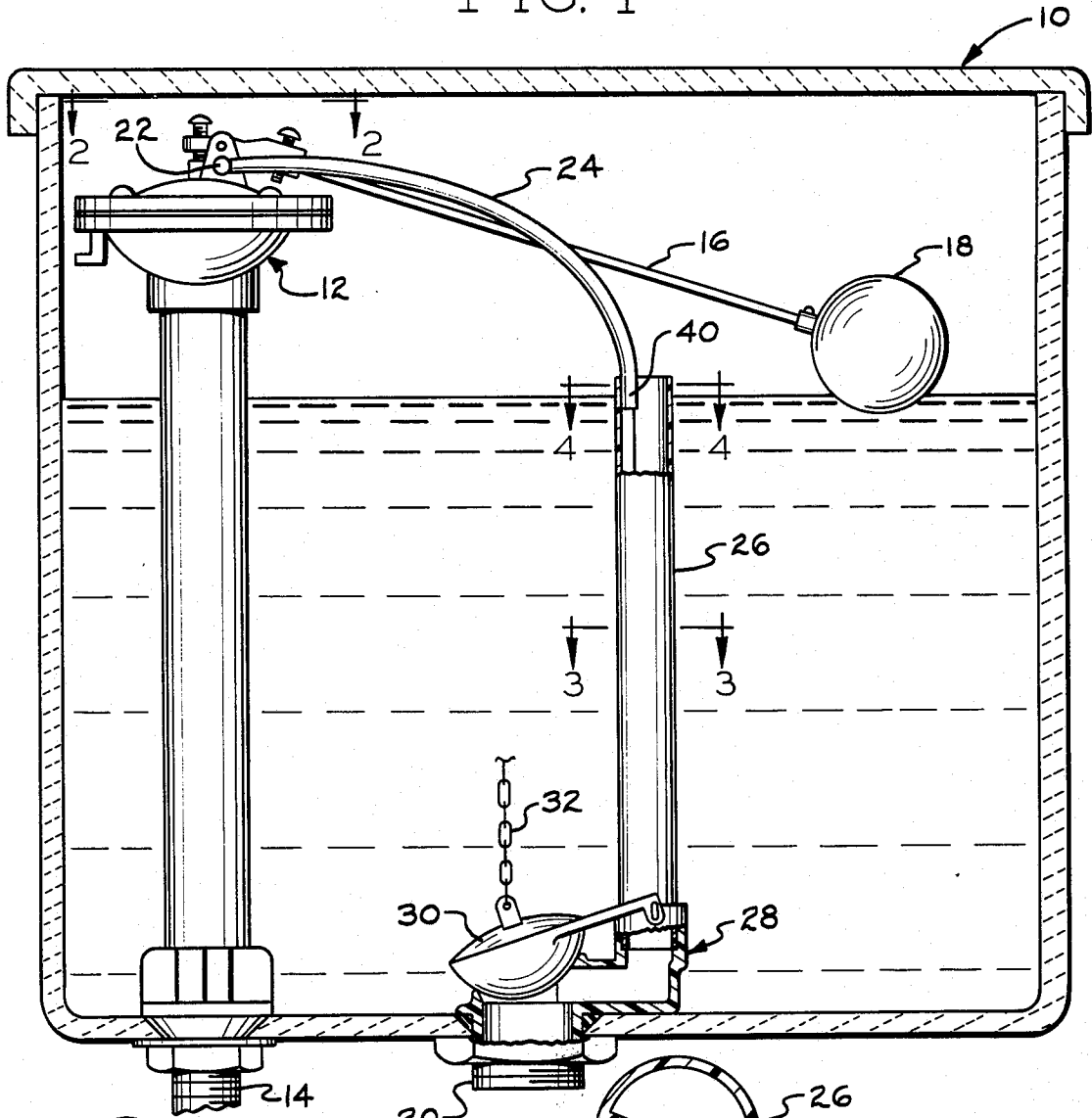

FIG. 2

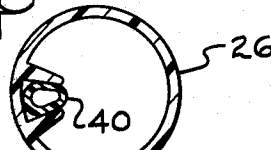

FIG. 4

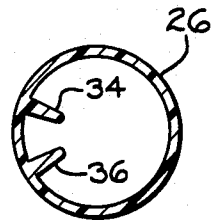

FIG. 3

## TOILET FLUSH TANK APPARATUS

### BACKGROUND OF THE INVENTION

The present invention relates to improvements in toilet flush tank apparatus, and particularly to the overflow tube and the associated refill tube that permits flow of water from the ballcock through the overflow tube to the toilet bowl for refilling the toilet bowl after a flush operation.

It is conventional practice to provide a toilet flush tank with a ball cock assembly for automatically refilling the tank after each flush of the toilet. In the conventional systems a flush valve is operated by the ball cock assembly to open when manually actuated and to close in response to operation of the ball cock assembly to enable the tank to be refilled. In these systems an overflow pipe is provided which in emergencies will accommodate excessive water that may rise above the end of the overflow tube, and such water can descend through the tube and under the valve flapper of the flush valve to the toilet bowl.

The conventional systems also have a refill tube that extends between the ball cock and the overflow tube to allow the toilet bowl to be refilled with water after the flush valve has closed and while the tank is being recharged. It is necessary that the refill tube be suitably connected to the overflow tube to provide appropriate communication for flow of water from the ball cock to the overflow tube. The existing or conventional systems do not fully meet the needs of the industry, because they require special attachment means to hold the fill tube in proper place to assure that the desired communication for flow of water is maintained. Thus, there is a need for improved, low cost apparatus of this character which provides the noiseless and dependable flow that is desired.

### SUMMARY OF THE INVENTION

The present invention has overcome the inadequacies of the prior art and has provided an improved upright overflow tube for use in conjunction with a flexible refill tube so that dependable flow communication is always maintained under quiet operating conditions and at relatively low cost.

According to one form of the present invention apparatus is provided for use in a toilet tank in which are mounted a ball cock which is in communication with a source of water and also an outlet valve and associated overflow tube that are in communication with the toilet bowl. The ball cock has an outlet fitting for supplying refill water to the toilet bowl subsequent to a flush of the toilet. The apparatus includes an upright overflow tube which is a plastic extrudate having two longitudinally extending radially inwardly directed flanges emanating from the inner wall of the tube. The flanges are adjacent to one another, and a flexible refill tube, which is connected at one end to the outlet fitting of the ball cock, has its other end retained within the confines of the radially inwardly directed flanges and the inner wall of the overflow tube. The flexible refill tube has resilient properties so that it can readily be deformed, out-of-round at said other end, for insertion within the confines of the flanges and the inner wall of the tube, and its resilient properties will enable the end to be retained frictionally within said confines.

Thus, it is an object of the present invention to provide improvements relating to the overflow tube and

associated refill tube as used in toilet flush apparatus.

Other objects of this invention will appear in the following description and appended claims, reference being had to the accompanying drawings forming a part of this specification wherein like reference characters designate corresponding parts in the several views.

### BRIEF DESCRIPTION OF THE DRAWINGS

FIG. 1 is a vertical section through a toilet flush tank containing one embodiment of the present invention;

FIG. 2 is a top plan view of the ball cock mounted in the flush tank as seen from the line 2—2 of FIG. 1;

FIG. 3 is a section taken on the line 3—3 of FIG. 1; and

FIG. 4 is a section taken on the line 4—4 of FIG. 1.

### DESCRIPTION OF THE PREFERRED EMBODIMENT

Before explaining the present invention in detail, it is to be understood that the invention is not limited in its application to the details of construction and arrangement of parts illustrated in the accompanying drawing, since the invention is capable of other embodiments and of being practiced or carried out in various ways. Also, it is to be understood that the phraseology or terminology employed herein is for the purpose of description and not of limitation.

Referring now to the drawing, the invention will be described in greater detail. The toilet flush tank and cover 10 are conventional in construction and include a ball cock assembly 12 which is secured to the bottom wall of the tank and is connected to a source of water or standpipe 14. In the conventional manner, the ball cock assembly 12 has a float arm 16 and a float 18 for actuating the ball cock assembly when the tank flush lever (not shown) is actuated for discharging water from the tank to the bowl of the toilet (not shown) via the discharge pipe 20, and the ball cock assembly 12 has an outlet fitting 22 to which one end of the flexible refill tube 24 is connected.

The other end of the flexible refill tube 24 extends into and is attached to the overflow tube 26 which is connected to the flush valve assembly 28. The latter is mounted on the bottom wall of the flush tank 10 in communication with the discharge pipe 20 and includes the flapper valve element 30. The latter is pivotally mounted on the body of the flush valve assembly 28 and a chain 32 is connected at one end to the flapper valve element 30 for lifting it and is connected at the other end to a flush lever (not shown) which is operable to raise the chain and thereby the flapper valve element 30 when the flush actuating handle of the toilet is actuated.

The apparatus described above is known in the prior art. In the normal operation of this apparatus when the toilet is flushed, the flush lever (not shown) will cause the flapper valve element to be raised, discharging the water in the tank 10 via the discharge pipe 20 to the bowl of the toilet. When the water within the tank has descended and the flapper valve element 30 has returned to its closed position shown in FIG. 1, the float 18 and its associated arm 16 will open the ball cock assembly 12 so that water can flow from the standpipe 14 to refill the tank 10. During this time of refilling, water can flow out of the outlet fitting 22 through the flexible refill tube 24, through the overflow tube 26 and under the flapper valve element 30 to the toilet bowl to refill

the latter after the flush operation has been completed. This refilling can continue until the float 18 and float arm 16 are elevated by the incoming water to a sufficient height, at which time the ball cock 12 will close interrupting any further flow of water from the stand-pipe 14.

An important feature of the present invention is the construction of the overflow tube 26 and the arrangement for attaching the flexible refill tube 24 thereto. The overflow tube is a thermoplastic extrudate which has radially inwardly directed flanges 34 and 36 extending its full length. These flanges are in closely spaced relationship of a dimension so that the flexible refill tube 24 can be partially pinched together at its one end and can be inserted between the flanges 34 and 36 to be retained therein in frictional engagement. As can be seen in FIG. 4, the flexible refill tube has its one end 38 connected to the outlet fitting 22 of the ball cock assembly 12 and its other end 40 retained within the confines of the upper portions of the radially inwardly directed flanges 34 and 36 and the inner wall of the overflow tube 26. The flexible refill tube 24 has resilient properties so that it can readily be deformed out-of-round at said other end for insertion within the confines of the flanges 34 and 36 and the inner wall of the overflow tube 26. Its resilient properties will enable the end to return elastically toward its round configuration so that it is retained frictionally within said confines as can be seen in FIG. 4.

By virtue of the construction and arrangement of the flexible refill tube 24 and the overflow tube 26, the need for separate clips or other retaining means for holding the end 40 of the refill tube 24 in the overflow tube 26 is unnecessary. Further, the flanges 34 and 36 hold the end 40 in such a position that the water which

flows from the ballcock assembly 12 through the overflow tube 26 will be confined within a relatively restricted passageway so that noiseless flow of the water through the tube is provided. Thus, low cost apparatus is provided which operates very effectively and noiselessly. Further, the construction and arrangement simplifies installation.

It is claimed:

1. In a toilet flush tank in which are mounted (1) a ball cock that is in communication with a source of water and (2) an outlet valve and an associated upright overflow tube that are in communication with the toilet flush tank outlet for discharge of water to a toilet bowl, said ball cock having an outlet fitting for supplying refill water to the toilet bowl subsequent to a flush of the toilet, the improvement comprising said overflow tube being an extrudate of thermoplastic material having a uniform cross-section throughout its length and including two integral flanges radially inwardly directed from the inner wall of the tube the full length thereof, said flanges being adjacent to one another to provide a relatively restricted longitudinal passageway the length of the tube, and a flexible refill tube connected at one end to said outlet fitting and having its other end retained within the confines of the upper portions of said radially inwardly directed flanges and the inner wall of said overflow tube.

2. The improvement that is defined in claim 1, wherein said flexible refill tube has resilient properties so that it can readily be deformed out-of-round at said other end for insertion within said confines, and its resilient properties will enable said other end to return toward its round configuration for frictional retention within said confines.

\* \* \* \* \*

40

45

50

55

60

65