



US 20070199917A1

(19) **United States**

(12) **Patent Application Publication**
Beaver et al.

(10) **Pub. No.: US 2007/0199917 A1**

(43) **Pub. Date: Aug. 30, 2007**

(54) **DEVICE AND METHOD FOR PREVENTING SKIDDING OF A CONTAINER**

(22) Filed: **Oct. 6, 2006**

Related U.S. Application Data

(75) Inventors: **Ted L. Beaver**, Roselle, IL (US);
Theodore Guss, Lakeland, TN (US);
Rick Estabrook, Milford, MA (US)

(63) Continuation of application No. 10/036,901, filed on Dec. 21, 2001, now abandoned.

Publication Classification

Correspondence Address:

ALSTON & BIRD LLP
BANK OF AMERICA PLAZA
101 SOUTH TRYON STREET, SUITE 4000
CHARLOTTE, NC 28280-4000 (US)

(51) **Int. Cl.**
B65D 90/02 (2006.01)
(52) **U.S. Cl.** **215/382**

(73) Assignee: **CONSOLIDATED CONTAINER COMPANY LP**, Atlanta, GA (US)

(57) **ABSTRACT**

A container having a side wall having an exterior surface with at least one friction portion effective to prevent skidding of the side wall on a surface adjacent the side wall.

(21) Appl. No.: **11/539,505**

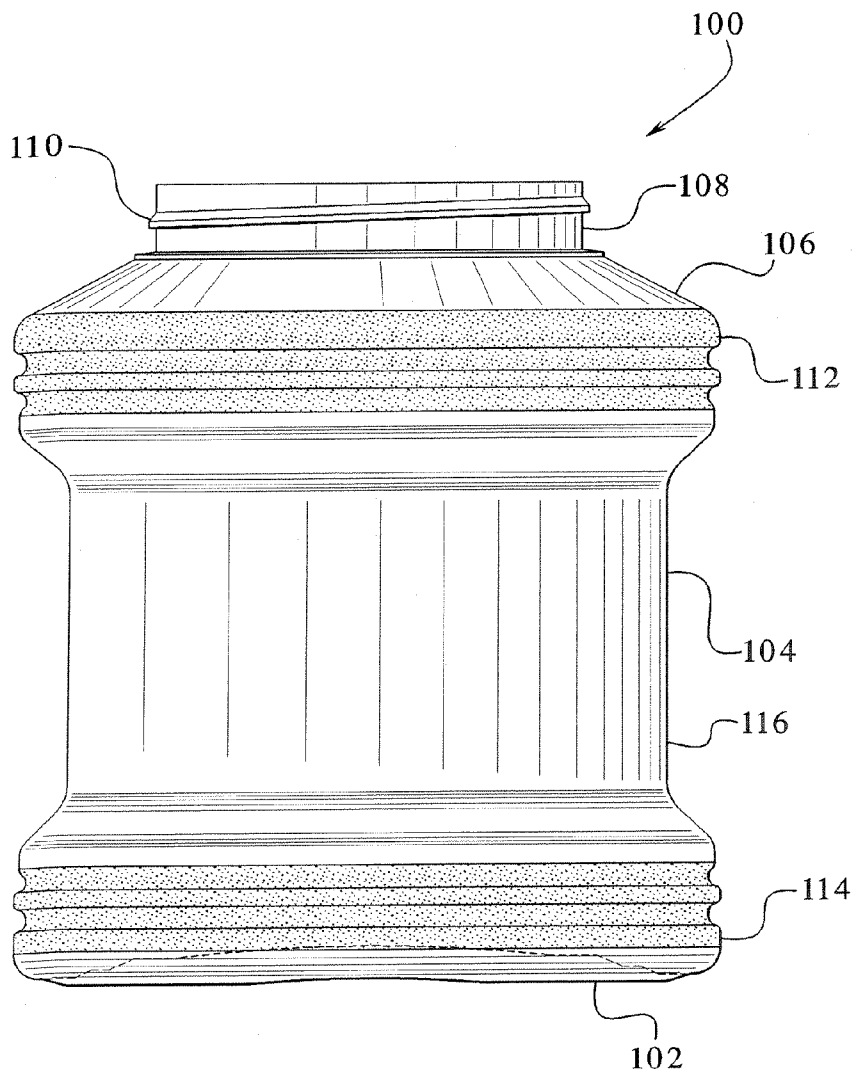

FIG. 1

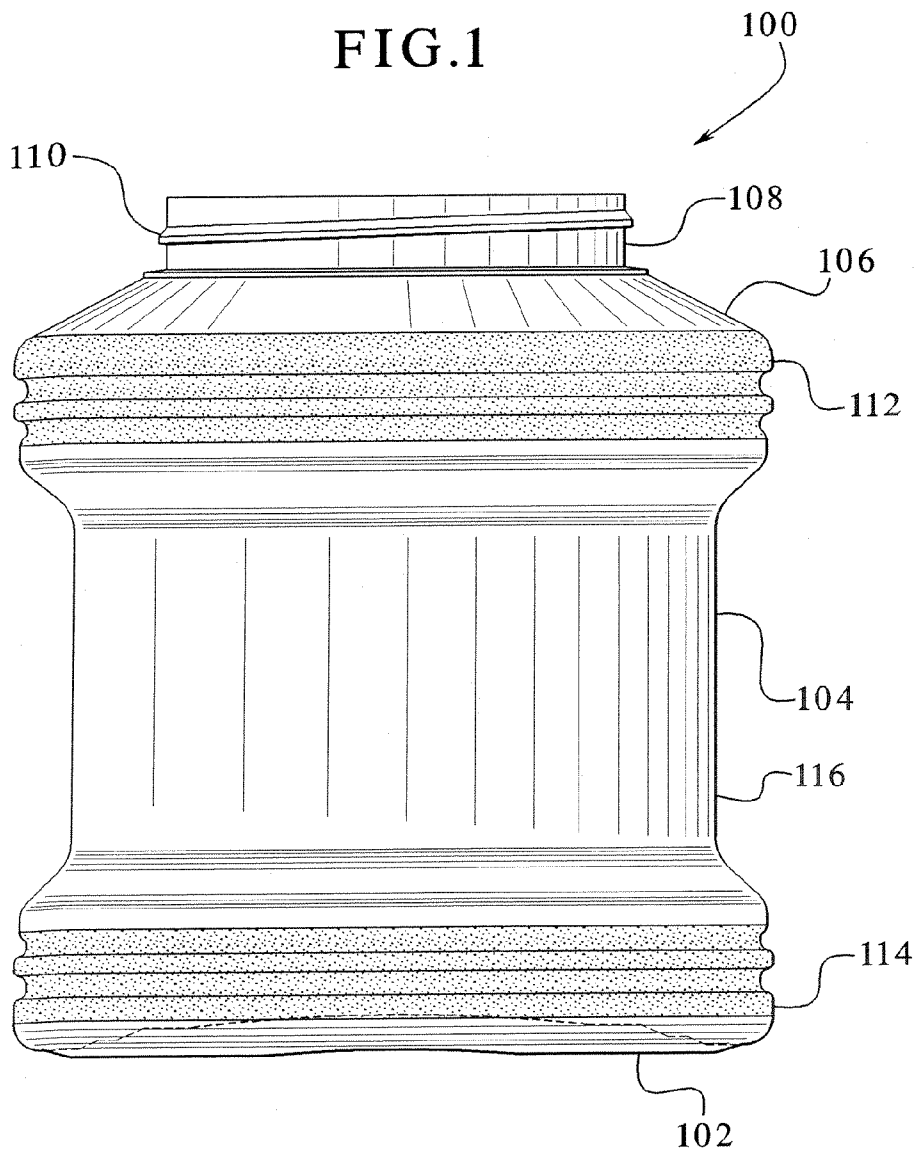

FIG. 3

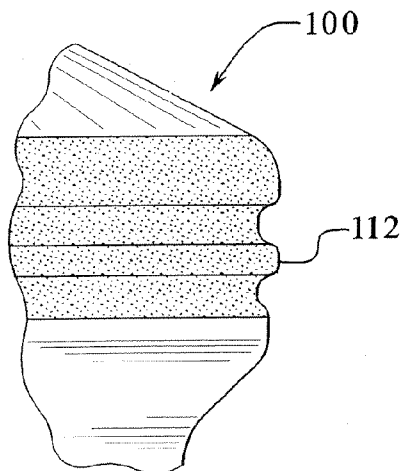

FIG. 4

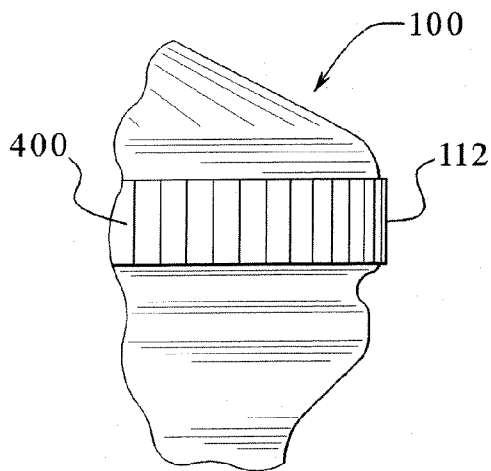

FIG. 2

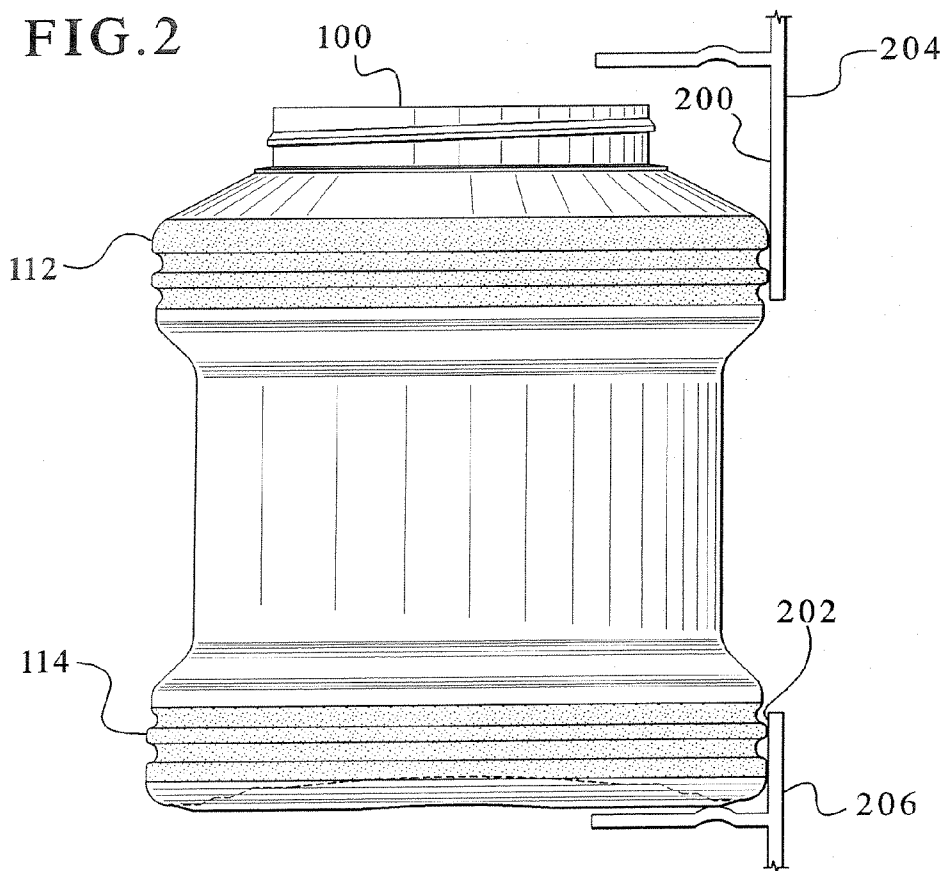

FIG. 5

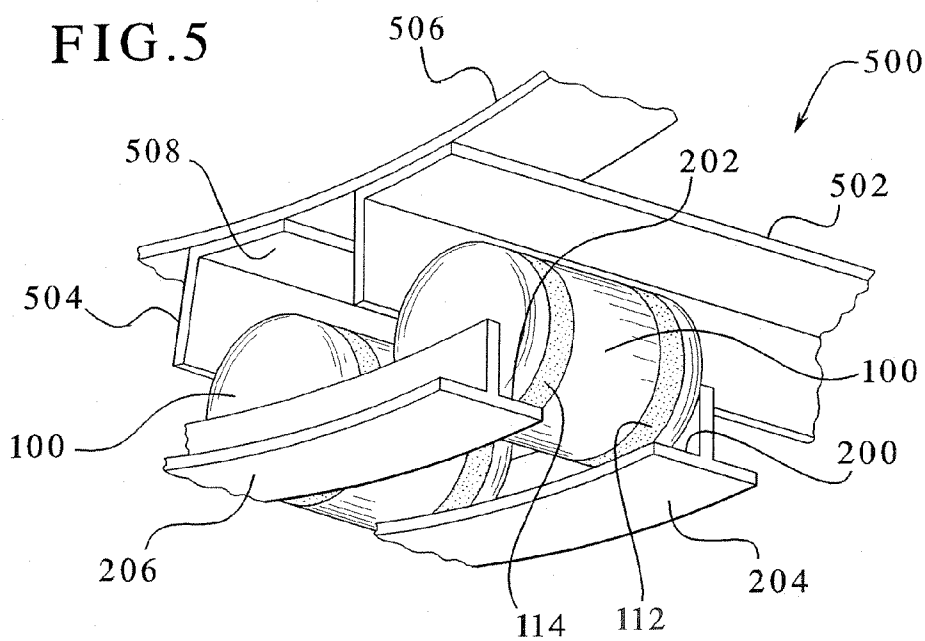

FIG. 6

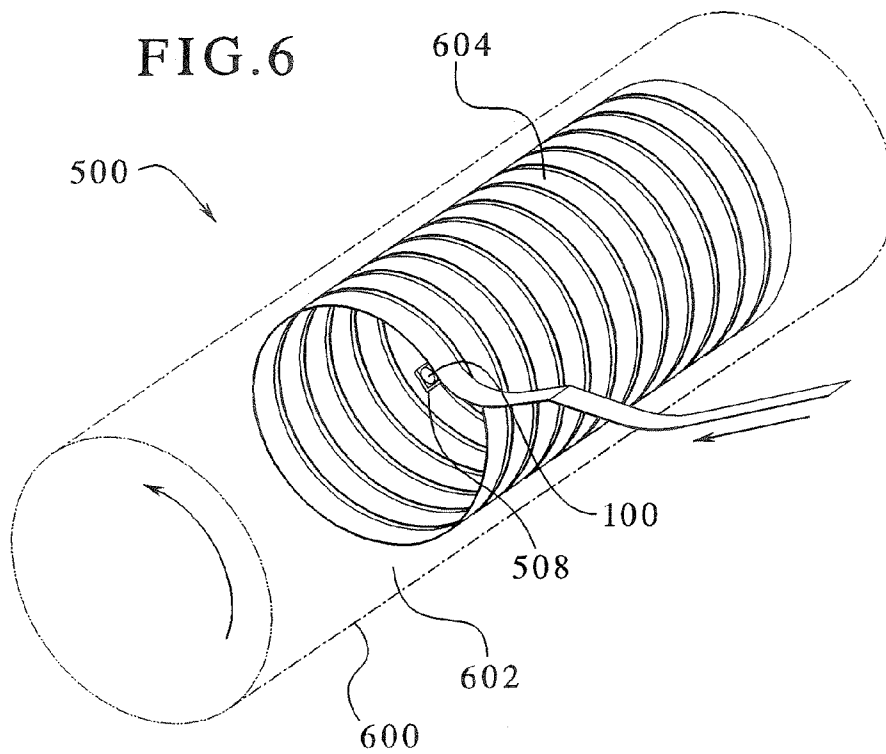
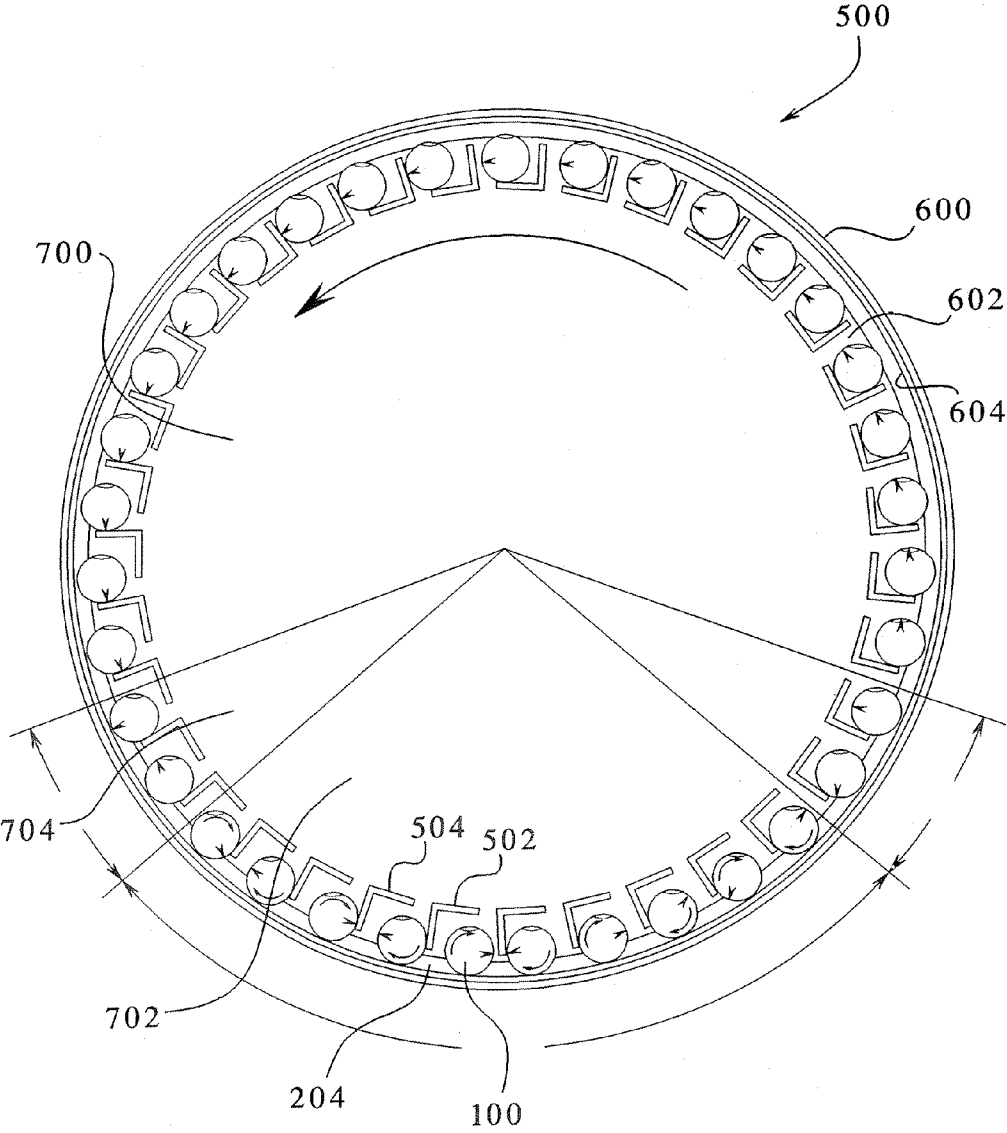
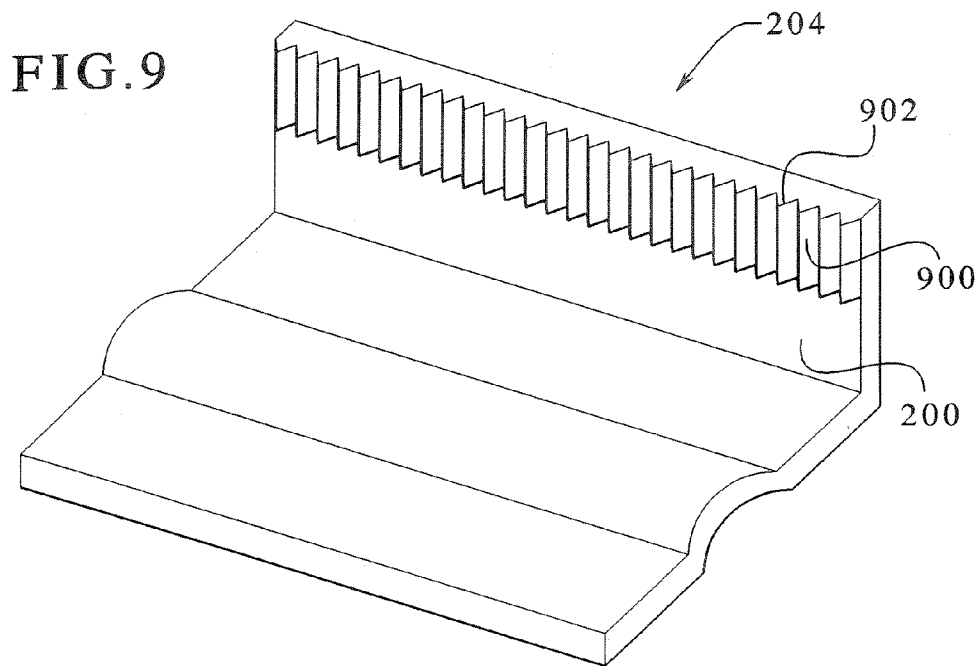
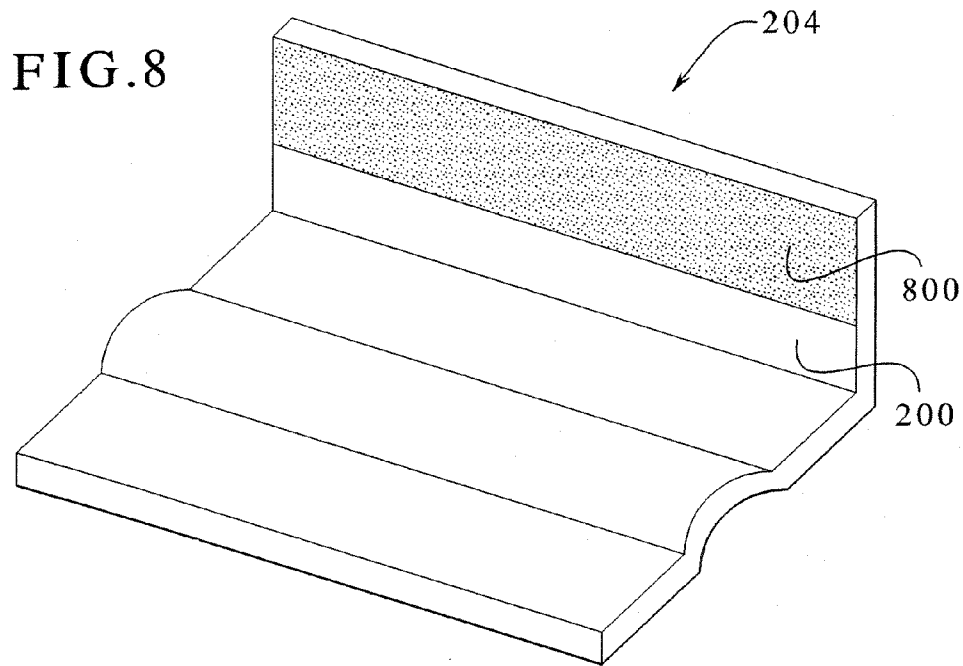

FIG. 7





DEVICE AND METHOD FOR PREVENTING SKIDDING OF A CONTAINER

CROSS-REFERENCE TO RELATED APPLICATIONS

[0001] This application is a continuation of U.S. application Ser. No. 10/036,901, filed Dec. 21, 2001, which is hereby incorporated herein in its entirety by reference.

BACKGROUND OF THE INVENTION

[0002] The present invention generally relates to containers. More particularly, the present invention relates to the conveying of containers.

[0003] In container filling and packaging operations, containers are guided by surfaces, such as rails, that are adjacent side walls of the containers. As a container is conveyed against an adjacent surface, the container typically “skids” along the surface on its way to an intended destination. In a case of a round container, the round container experiences little or no rotation as it skids along the adjacent surface.

[0004] For example, in a rotary-style heater/cooler that has a horizontal cylindrical rotating portion that horizontally rotates on its center axis, containers are housed within carrier pockets located about an interior surface of the rotating portion. The carrier pockets comprise rails that generally restrict the containers’ movement in each direction, yet permit the containers to move some and to rotate within the carrier pockets.

[0005] As the rotating portion rotates, the containers move in a spiral path along the length of the horizontal cylindrical rotating portion. Containers that are located in a lower part of the rotary-style heater/cooler are in contact with an exterior rail toward an exterior of the rotating portion due to gravity. For round containers, the frictional forces between the side walls of the containers and the exterior rail have a tendency to rotate the containers against the exterior rail. In other words, as the rotating portion rotates about its center axis, a round container has a tendency to rotate about its center axis while it is positioned in a lower part of the rotating portion. This rotation causes some mixing of the contents of the containers to assist heat transfer through the contents during heating or cooling of the container and its contents. Due to the low coefficients of friction of typical container and typical exterior rails, however, the containers have a tendency to skid along the exterior rails. Therefore, the containers do not typically continuously rotate while in the lower portion of the heater/cooler.

[0006] Also, frictional defects, such as abrasions and scuff marks, can occur on the side walls of the containers as the containers skid along the adjacent surface. Accordingly, typical containers and typical exterior rails do not provide enough frictional forces to provide enough rotation to sufficiently mix some contents or to effect efficient heat transfer throughout the contents. Further, this phenomenon is not limited to rotary-style heaters/coolers and typically occurs when containers travel against adjacent surfaces.

SUMMARY OF THE INVENTION

[0007] The present disclosure provides one or more inventions directed to preventing skidding of containers on adjacent surfaces. These improvements can be practiced jointly or separately.

[0008] To this end, in an embodiment, there is provided a container comprising a side wall having an exterior surface with at least one friction portion effective to prevent skidding of the side wall on a surface adjacent the side wall.

[0009] In an embodiment, the friction portion encompasses substantially all of the exterior surface of the side wall.

[0010] In an embodiment, the friction portion encompasses less than the entire exterior surface of the side wall, the friction portion having a coefficient of friction that is higher than that of a remainder of the side wall.

[0011] In an embodiment, the friction portion comprises a stippled surface protruding from the side wall.

[0012] In an embodiment, the friction portion comprises wall members positioned about the side wall, the wall members being protrusions from the side wall and effective to engage complementary protrusions of the surface adjacent the side wall.

[0013] In an embodiment, the friction portion is integral to the exterior surface of the sidewall.

[0014] In an embodiment, the friction portion is an embossed structure on the exterior surface of the side wall.

[0015] In an embodiment, the friction portion is attached to the exterior surface of the sidewall.

[0016] In an embodiment, the container comprises at least one of metal, plastic, and glass.

[0017] In an embodiment, the container comprises a plurality of friction portions on the exterior surface of the side wall. In an embodiment, the friction portions encompass less than the entire exterior surface of the side wall, each of the friction portions having a coefficient of friction that is higher than that of a remainder of the side wall.

[0018] There is also provided, in an embodiment, an anti-skid device comprising an engagement surface having a friction portion effective to prevent skidding of a container against the engagement surface.

[0019] There is also provided, in an embodiment, a method of preventing skidding of a container having a side wall on a surface adjacent the side wall. The method comprises the steps of: providing a container having a side wall with an exterior surface; and providing a surface adjacent the exterior surface of the side wall, wherein at least one of the exterior surface of the side wall and the surface adjacent the exterior surface of the side wall comprises a friction portion effective to prevent skidding of the exterior surface of the side wall on the surface adjacent the exterior surface of the side wall.

[0020] There is also provided, in an embodiment, a method of preventing skidding of a container having a side wall on a surface adjacent the side wall. The method comprises the steps of: providing a container having a side wall with a friction portion; and providing a surface adjacent the side wall, the friction portion effective to prevent skidding of the side wall on the surface adjacent the side wall.

[0021] There is also provided, in an embodiment, a method of preventing skidding of a container having a side wall on a surface adjacent the side wall. The method comprises the steps of: providing a container having a side

wall; and providing a surface adjacent the side wall, the surface adjacent the side wall having a friction portion effective to prevent skidding of the side wall on the surface adjacent the side wall.

[0022] These and other features of the present invention will become clearer with reference to the following detailed description of the presently preferred embodiments and accompanying drawings.

DESCRIPTION OF THE DRAWINGS

[0023] FIG. 1 is a side elevational view of a container constructed in accordance with the present invention.

[0024] FIG. 2 is a side elevational view of the container of FIG. 1 adjacent exterior rails.

[0025] FIG. 3 is a side elevational view of the container of FIG. 1 having a friction portion in accordance with an embodiment of the present invention.

[0026] FIG. 4 is a side elevational view of the container of FIG. 1 having a friction portion in accordance with another embodiment of the present invention.

[0027] FIG. 5 is a perspective view of the container of FIG. 1 within a rotary-style heater/cooler in accordance with an embodiment of the present invention.

[0028] FIG. 6 is a sectional view of a rotary-style heater/cooler.

[0029] FIG. 7 is a side elevational view of a plurality of containers within a rotary-style heater/cooler in accordance with embodiments of the present invention.

[0030] FIG. 8 is a perspective view of an exterior rail in accordance with an embodiment of the present invention.

[0031] FIG. 9 is a perspective view of an exterior rail in accordance with another embodiment of the present invention.

DETAILED DESCRIPTION OF THE PRESENTLY PREFERRED EMBODIMENTS

[0032] As described above, there is provided a device and method for preventing skidding of a side wall of a container on an adjacent surface.

[0033] In FIG. 1, there is depicted an illustrative container 100 constructed in accordance with the present invention. As illustrated, the container 100 has a bottom portion 102, a side wall 104 having a shoulder 106, and a neck 108. An opening in the neck 108 of the container 100 can be closed by any suitable structure. For example, as illustrated, the neck 108 can have threads 110 for engaging a closure (not shown).

[0034] The container 100 is not limited to the illustrated shapes and topologies and can embody shapes and/or topologies different from those illustrated. For example, the container 100 can have a handle. Further, the container can conform to an industry-standard shape, such as, a shape that meets the specifications of an industry-standard #10 can.

[0035] The container 100 can comprise any suitable material or combination of materials. For example, the container can comprise at least one of metal, plastic, and glass.

[0036] A first friction portion 112 and a second friction portion 114 are formed about the side wall 104. In the

illustrated embodiment, there are two friction portions 112 and 114. In alternate embodiments, there can be one or more friction portions formed about the side wall 104. In an embodiment, the container 100 can have a single friction portion encompassing substantially all of the side wall 104. The first friction portion 112 and the second friction portion 114 are depicted as horizontal bands formed about the circumference of the container 100. Alternatively, the friction portions can be formed to any shape that is suitable to provide friction on an adjacent surface. For example, the friction portion can be formed as a spiral about the container's circumference and along the side wall 104, a pattern of disconnected friction portions, or bands that do not have linear edges.

[0037] In the illustrative embodiment, the friction portions 112 and 114 are separated by other portions of the side wall 104. The friction portions 112 and 114 may have coefficient of friction values that are larger than coefficient of friction values of the remainder of the side wall 104, however, the coefficient of friction values of the friction portions 112 and 114 may be equal to the coefficient of friction values of the other portions of the side wall 104. Also, the friction portions 112 and 114 can each have different coefficient of friction values.

[0038] The friction portions 112 and 114 can be, for example, integral to the side wall 104. In this case, the friction portions 112 and 114 can be, for example, texturing formed or embossed on the side wall 104. The texturing can comprise, for example, stippling, projecting or raised portions, or a rough surface.

[0039] Alternatively, the friction portions 112 and 114 can be devices attached to the side wall 104. In this case, the friction portions 112 and 114 have textured outer surfaces. The texturing can comprise, for example, stippling, projecting or raised portions, or a rough surface. Additional embodiments of friction portions 112 and 114 are described below with reference to FIGS. 3 and 4.

[0040] A recessed portion 116 is formed between the first friction portion 112 and the second friction portion 114. In alternate embodiments, the container 110 does not have a recessed portion 116, or the container has a plurality of recessed portions 116.

[0041] In the illustrative embodiment, the friction portions 112 and 114 of side wall 104 have a coefficient of friction value that is greater than a coefficient of friction value of a remainder of the side wall 104. Accordingly, when the friction portions 112 and 114 contact an adjacent surface, such as a rail in a rotary-style heater/cooler, the friction portions 112 and 114 provide more friction against the rail than would be provided by the remainder of the side wall 104.

[0042] FIG. 2 depicts the container 100 contacting against a first adjacent surface 200 and a second adjacent surface 202. In the illustrated embodiment, the first adjacent surface 200 is a surface of a first exterior rail 204 of a rotary-style heater/cooler. The second adjacent surface 202 is a surface of a second exterior rail 206 of the rotary-style heater/cooler. Alternatively, the first adjacent surface 200 and the second adjacent surface 202 can be any surface that is adjacent the side wall 104 of the container 100.

[0043] As illustrated, the first friction portion 112 contacts against the first adjacent surface 200 and the second friction

portion **114** contacts against the second adjacent surface **202**. Since the container **100** has friction portions **112** and **114**, which have a coefficient of friction value that is greater than the coefficient of friction value of the remainder of the side wall **104**, there is a greater amount of friction between the container **100** and the adjacent surfaces **200** and **202** than there would be between a typical container and the adjacent surfaces **200** and **202**. Accordingly, the container **100** is less likely to skid against the adjacent surfaces **200** and **202** than a typical container that does not have a friction portion.

[0044] FIG. 3 depicts a first embodiment of the friction portions of the container **100**. In the illustrated embodiment, the first friction portion **112** comprises a rough surface, such as, for example, a stippled surface. The stippled surface can be, for example, MT11100 standard texturing.

[0045] FIG. 4 depicts another embodiment of the friction portions of the container **100**. In the illustrated embodiment, the first friction portion **112** comprises a number of gear teeth or ribs **400** formed about a circumference of the side wall **104**. The ribs **400** are at least partially aligned in a direction of a height or longitudinal axis of the container **100**. Alternatively, the ribs **400** can have a different alignment. In an embodiment, a surface that is adjacent the friction portions can have complementary ribs formed thereon to engage the ribs **400** of the friction portions, as will be described in more detail below.

[0046] Although the first friction portion **112** is depicted in FIGS. 3 and 4, the illustrated embodiments can also disclose any other friction portions of the container **100**, such as the second friction portion **114**. Further, in alternate embodiments, the friction portions can have configurations that are different from those illustrated in FIGS. 3 and 4. For example, the friction portions can comprise a plurality of connected or disconnected protrusions of any shape that is suitable for providing a desired coefficient of friction.

[0047] The above-described container **100** provides a side wall having a larger coefficient of friction value than typical containers. This provides advantages over typical containers when a side wall having a large coefficient of friction value is desired. For example, when a container is heated/cooled in a rotary-style heater/cooler, it is beneficial for the container's side wall to have a large coefficient of friction in order to prevent skidding of the container on the exterior rails of the rotary-style heater/cooler. FIG. 5 depicts a perspective view of the container **100** within a rotary-style heater/cooler in accordance with an embodiment of the present invention. The rotary-style heater/cooler is designated generally as item **500**.

[0048] As described above, and referring to FIG. 6, the rotary-style heater/cooler **500** has a horizontal cylindrical rotating portion **600** that rotates on its center axis. The illustrative rotating portion **600** is depicted to rotate in a counter-clockwise direction, as indicated by the arrow, however, the rotating portion **600** can alternatively rotate in a clockwise direction. A plurality of containers **100** are housed within carrier pockets **508** located about an interior **602** of the rotating portion **600**.

[0049] Referring back to FIG. 5, a container **100** is housed within a carrier pocket **508** in a space that has boundaries comprising the first exterior rail **204**, the second exterior rail **206**, a first inner rail **502**, and a second inner rail **504**. The

first inner rail **502** and the second inner rail **504** are connected via a mounting rail **506**. The carrier pockets **508** are large enough, however, to permit the containers **100** to move some and to rotate within the carrier pockets **508**. The first exterior rail **204** and the second exterior rail **206** are formed such that the containers move in a spiral path **604** along the length of the rotary-style heater/cooler **500** as the rotating portion **600** rotates.

[0050] FIG. 7 depicts a cross-sectional view of the rotating portion **600**. As the rotating portion **600** rotates, containers **100** that are located in an upper part **700** of the rotary-style heater/cooler **500** are carried by an inner rail **502** or **504**. The upper part **700** comprises a distance of approximately 220 degrees around the periphery of the rotating portion **600**. While the containers **100** are carried, the containers **100** rest against the inner rail **502** or **504** and, for the most part, do not rotate.

[0051] Containers **100** that are located in a lower part **702** of the rotary-style heater/cooler **500** are in contact with the exterior rails **204** and **206** due to gravity. The frictional forces between the side walls **104** of the containers **100** and the exterior rail **204** and **206** cause the containers **100** to rotate against the exterior rails **204** and **206**. This is depicted by the rotation arrows illustrated within the containers **100**. In a transition part **704** that is between the upper part **700** and the lower part **702**, the containers **100** will rotate when they are in contact with the exterior rails **204** and **206**.

[0052] In the lower part **702** and in the transition part **704**, a typical container, however, has a tendency to skid against the rail due to the coefficients of friction of typical container side walls and typical exterior rails. In accordance with embodiments consistent with the present invention, however, the friction portions **112** and **114** of the side walls **104** of the containers **100** have a coefficient of friction value that is large enough to prevent the container **100** from skidding along the exterior rails **204** and **206**. Instead, the friction portions **112** and **114** grip the adjacent surfaces **200** and **202** of the exterior rails **204** and **206**, respectively, causing the containers **100** to continuously rotate while in the lower part **702** and transition part **704** of the rotary-style heater/cooler **500**. This continuous rotation advantageously causes the contents of the containers **100** to mix and, therefore, assists heat transfer through the contents during heating or cooling of the containers **100** and their contents. Further, since the side walls **104** of the containers **100** do not skid along the adjacent surfaces **200** and **202**, frictional defects, such as abrasions and scuff marks, are reduced.

[0053] In alternate embodiments of the present invention, friction portions, as described above, are provided on surfaces adjacent the container **100** instead of or in addition to being provided on the side wall **104** of the container **100**. Illustrative embodiments of the present invention that provide friction portions on adjacent surfaces are depicted in FIGS. 8 and 9. FIG. 8 illustratively depicts the first external rail **204** of the rotary-style heater cooler **500**. In the illustrated embodiment, the first external rail **204** comprises a rough surface, such as, for example, a stippled surface. As illustrated, a friction portion **800** is formed on the first adjacent surface **200**. The stippled surface can be, for example, MT11100 standard texturing. As the container **100** moves along the first adjacent surface **200**, the friction portion **800** prevents skidding of the container **100** on first adjacent surface **200**.

[0054] FIG. 9 depicts an embodiment wherein an alternative friction portion 900 is formed on the first adjacent surface 200. The friction portion 900 comprises a number of gear teeth or ribs 902 that protrude from first adjacent surface 200. The ribs 902 are at least partially aligned in a direction of a height or longitudinal axis of the container 100. Alternatively, the ribs 902 can have a different alignment. In a case wherein the container 100 has complementary ribs 400 formed thereon, as depicted in FIG. 4, the ribs 902 of the first adjacent surface 200 engage the ribs 400 of the container 100.

[0055] One of skill in the art will appreciate that the shapes of the friction portions 800 and 900 are merely illustrative and, similar to the friction portions 112 and 114, the friction portions 800 and 900 can have alternative configurations. For example, the friction portions can comprise a plurality of connected or disconnected protrusions or rough surfaces of any shape that is suitable for providing a desired coefficient of friction.

[0056] Further, the friction portions (e.g. friction portions 800 and 900) can be on surfaces other than on the exterior rails of a rotary-style heater/cooler. The friction portions can be formed on any surface that is adjacent the container 100, such as, on a conveyor, equipment rail, guard, wall, or base plate.

[0057] Therefore, the present apparatus and methods inventively reduce skidding between containers and adjacent surfaces compared to typical containers and adjacent surfaces.

[0058] As is apparent from the foregoing specification, the present invention is susceptible to being embodied with various alterations and modifications which may differ particularly from those that have been described in the preceding specification and description. It should be understood that it is desired to embody within the scope of the patent warranted herein all such modifications as reasonably and properly come within the scope of the presently defined contribution to the art.

We claim:

- 1. A container comprising:
 - a side wall having an exterior surface and at least one friction portion effective to prevent skidding of the side wall on a surface adjacent the side wall, wherein:
 - said container is adapted to be moved adjacent a circumferential surface of a rotary-style heater/cooler so that:
 - (A) said at least one friction portion engages said circumferential surface of said rotary-style heater/cooler as said container is moved adjacent said circumferential surface of said rotary-style heater/cooler; and
 - (B) said container continuously rotates as said container is moved adjacent said circumferential surface of said rotary-style heater/cooler, due to an engage-

ment between said at least one friction portion and said circumferential surface of said rotary-style heater/cooler.

2. The container of claim 1, wherein the friction portion encompasses substantially all of the exterior surface of the side wall.

3. The container of claim 1, wherein the friction portion encompasses less than the entire exterior surface of the side wall, the friction portion having a coefficient of friction that is higher than that of a remainder of the side wall.

4. The container of claim 1, wherein the friction portion comprises a stippled surface protruding from the side wall.

5. The container of claim 1, wherein the friction portion comprises wall members positioned about the side wall, the wall members being protrusions from the side wall and effective to engage complementary protrusions of said circumferential surface of said rotary-style heater/cooler.

6. The container of claim 1, wherein the friction portion is integral to the exterior surface of the side wall.

7. The container of claim 1, wherein the friction portion is an embossed structure on the exterior surface of the side wall.

8. The container of claim 1, wherein the friction portion is attached to the exterior surface of the side wall.

9. The container of claim 1, wherein the container comprises at least one of metal, plastic, and glass.

10. The container of claim 1, comprising a plurality of friction portions on the exterior surface of the side wall.

11. The container of claim 10, wherein the friction portions encompass less than the entire exterior surface of the side wall, each of the friction portions having a coefficient of friction that is higher than that of a remainder of the side wall.

12. The container of claim 1, wherein: said circumferential surface of said rotary-style heater/cooler comprises at least one rail.

13. The container of claim 1, wherein: said at least one friction portion comprises both a first friction portion and a second friction portion;

said interior surface of said rotary-style heater/cooler comprises both a first rail and a second rail;

said first friction portion is adapted to engage said first rail; and

said second friction portion is adapted to engage said second rail.

14. The container of claim 1, wherein:

said at least one friction portion comprises a first plurality of ribs that are at least partially aligned in a direction of a longitudinal axis of said container.

15. The container of claim 14, wherein: said circumferential surface comprises a second plurality of ribs that are complementary to said first plurality of ribs.

* * * * *