



US00D342930S

# United States Patent [19]

[11] Patent Number: **Des. 342,930**

Lewellen et al.

[45] Date of Patent: **\*\* Jan. 4, 1994**

[54] **PAIR OF TRUCK BODY SIDE PANELS**

[57] **CLAIM**

[75] Inventors: **Richard Lewellen; George Kalis, Jr.; Robert M. Lapsley**, all of Wooster, Ohio

The ornamental design for a pair of truck body side panels, as shown and described.

[73] Assignee: **The Scott Fetzer Company**, Westlake, Ohio

**DESCRIPTION**

[\*\*] Term: **14 Years**

FIG. 1 is a perspective view of the left side panel of a pair of truck body side panels showing our new design; FIG. 2 is a side elevational view of the left side panel thereof shown in FIG. 1;

[21] Appl. No.: **915,377**

FIG. 3 is a side elevational view of the right side panel thereof;

[22] Filed: **Jul. 16, 1992**

FIG. 4 is a greatly enlarged cross-sectional view as seen approximately from the plane indicated by the line 4—4 of FIG. 2;

**Related U.S. Application Data**

[63] Continuation-in-part of Ser. No. 870,040, Apr. 17, 1992.

FIG. 5 is a greatly enlarged cross-sectional view as seen approximately from the plane indicated by the line 5—5 of FIG. 2;

[52] U.S. Cl. .... **D12/196**

[58] Field of Search ..... 296/24.1, 183; D12/96, D12/98, 196

FIG. 6 is a top plan view as seen approximately from the plane indicated by the line 6—6 of FIG. 2; and, FIG. 7 is a bottom plan view as seen approximately from the plane indicated by the line 7—7 of FIG. 2.

**References Cited**

**U.S. PATENT DOCUMENTS**

D. 190,416	5/1961	Powers	.....	D12/98
3,596,976	8/1971	Eitel	.....	296/24.1
4,126,349	11/1978	Nelson et al.	.....	296/24.1
4,685,695	8/1987	Le Vee	.....	296/24.1

The section views of the right side panel corresponding to those shown in FIGS. 4 and 5 of the drawing are understood to be mirror images thereof, and the top and bottom views of the left side panel are mirror images of the right side panel shown in FIGS. 6 and 7 of the drawing.

*Primary Examiner*—James M. Gandy  
*Attorney, Agent, or Firm*—Watts, Hoffmann, Fisher & Heinke

The broken line showing of environmental structure in the drawing is for illustrative purposes only and forms no part of the claimed design.

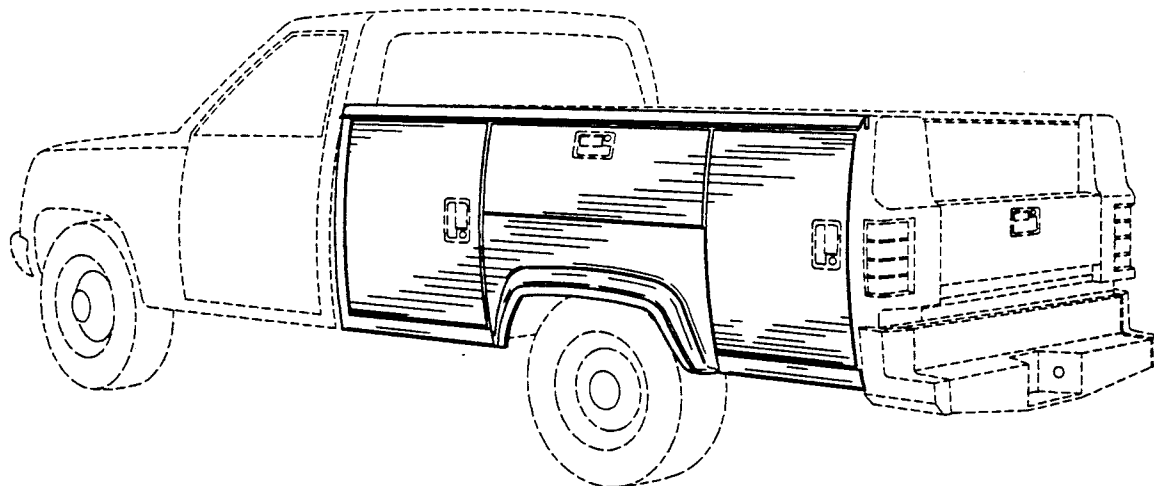

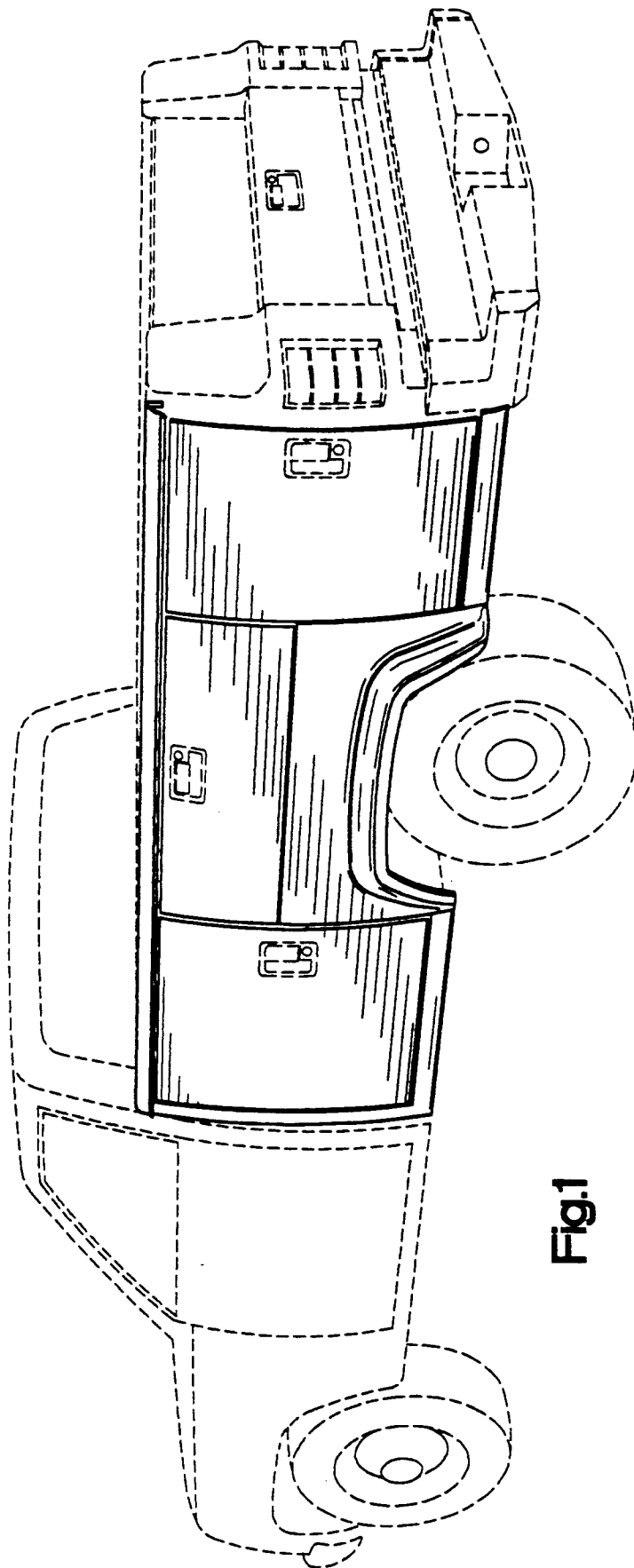

Fig.1

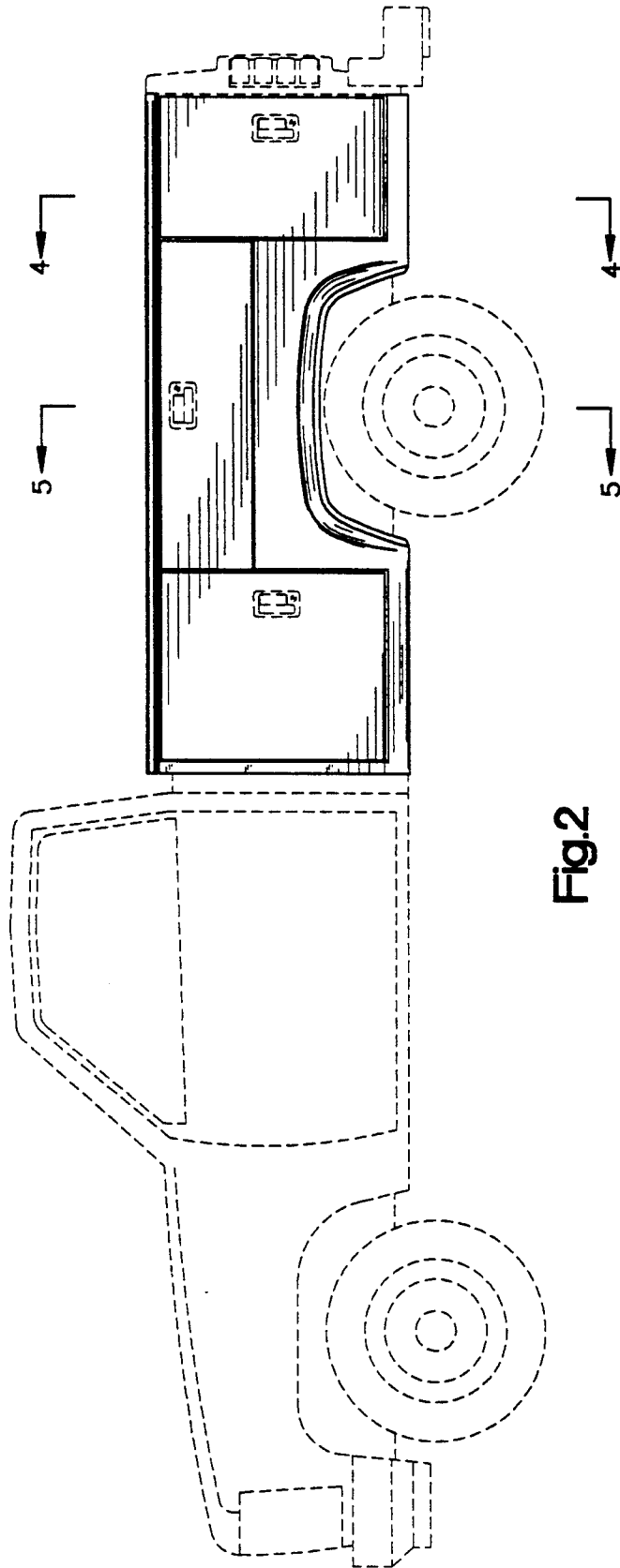

Fig.2

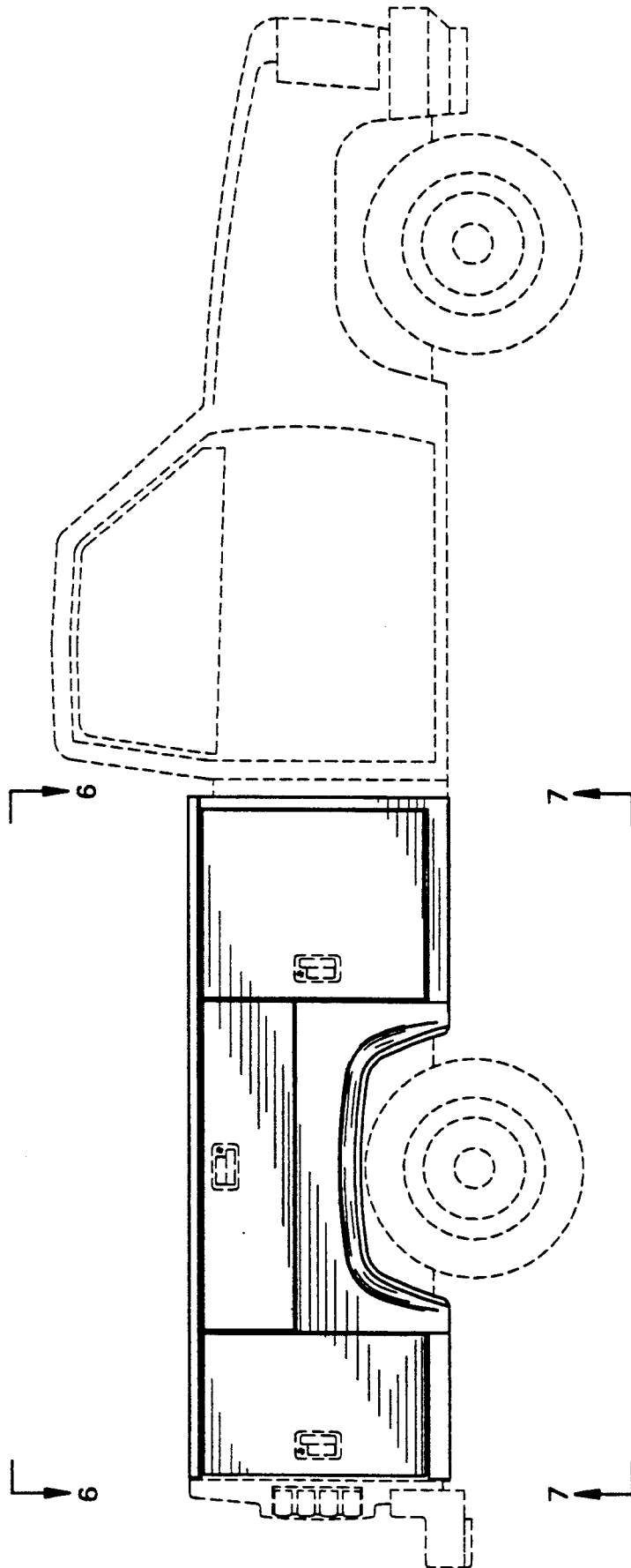

Fig.3

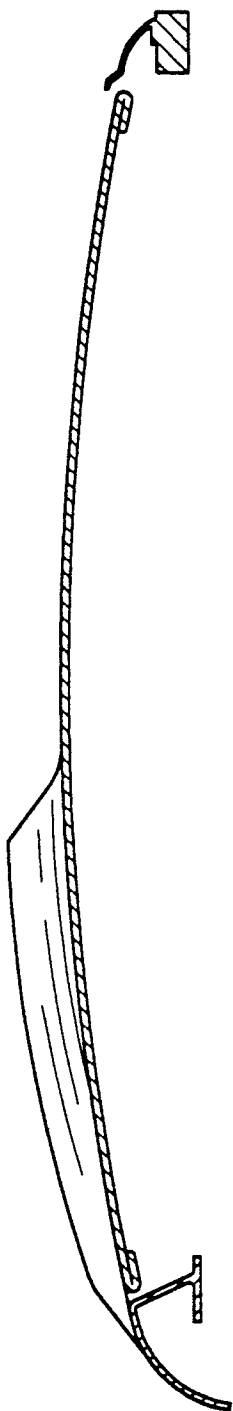

Fig.4

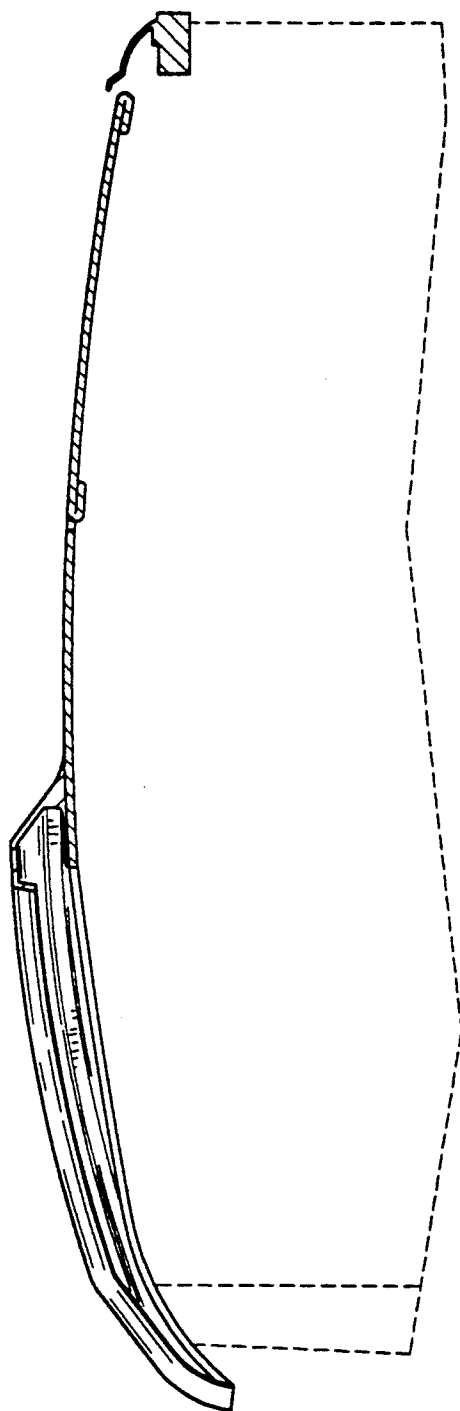

Fig.5

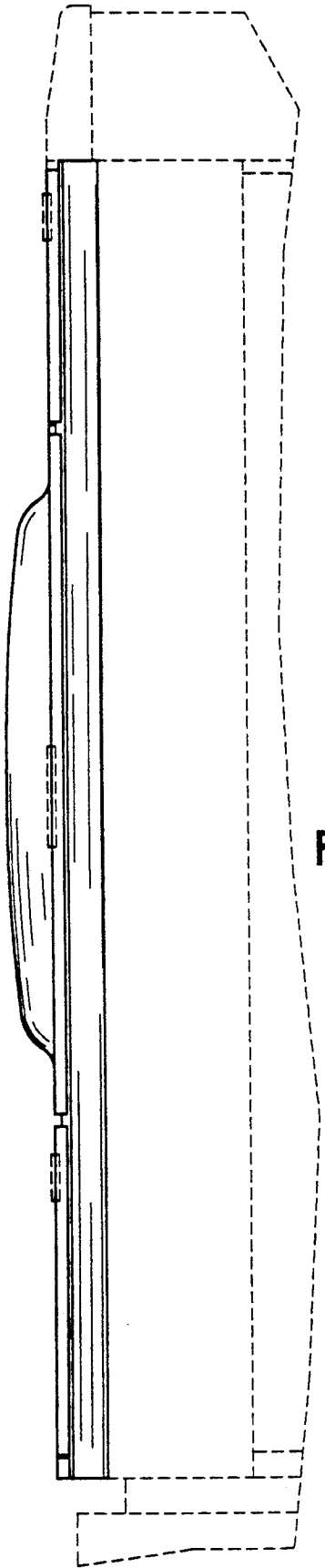

Fig.6

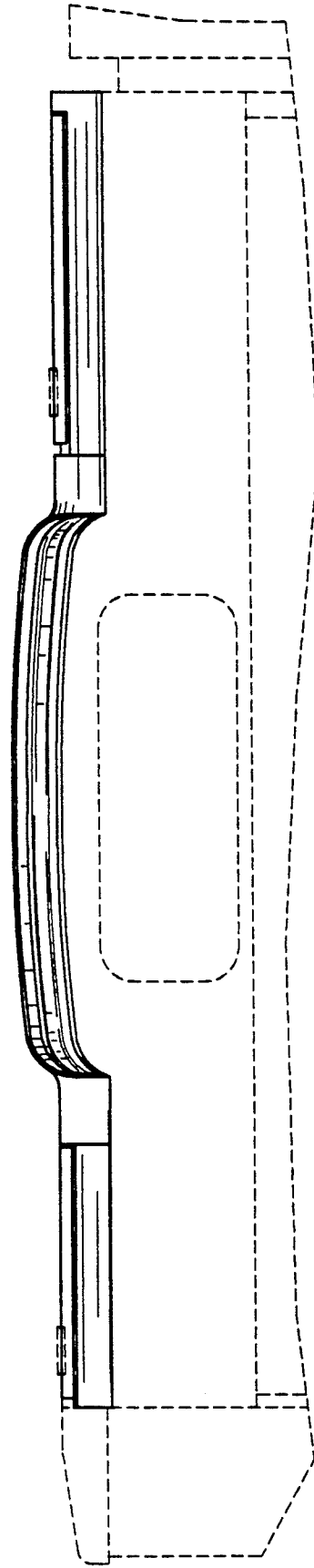

Fig.7