



(12) **United States Design Patent**
Layne

(10) **Patent No.:** **US D910,959 S**
(45) **Date of Patent:** **** Feb. 16, 2021**

- (54) **CONVEYOR GUIDERAIL**
- (71) Applicant: **SPAN TECH LLC**, Glasgow, KY (US)
- (72) Inventor: **James L. Layne**, Bowling Green, KY (US)
- (73) Assignee: **SPAN TECH LLC**, Glasgow, KY (US)
- (**) Term: **15 Years**
- (21) Appl. No.: **29/659,785**
- (22) Filed: **Aug. 13, 2018**

D110,439 S * 7/1938 Lowry D25/119
 2,156,020 A 4/1939 Lathrop et al.
 2,229,605 A 1/1941 Snyder et al.

(Continued)

FOREIGN PATENT DOCUMENTS

DE	1244652 B	7/1967
GB	1521967 A	8/1978
JP	08058967	3/1996

OTHER PUBLICATIONS

Bethlehem Steel Extrusions Catalog 1951, Carbon Steel Bars—Representative Sections—p. 11, Fourth shape from the left on row 9. (Year: 1951).*

(Continued)

Primary Examiner — Cynthia Ramirez
(74) *Attorney, Agent, or Firm* — King & Schickli, PLLC

(57) **CLAIM**

The ornamental design for a conveyor guiderail, as shown and described.

DESCRIPTION

FIG. 1 is a perspective view of a conveyor guiderail showing my new design;
 FIG. 2 is a front view of the curved guiderail of FIG. 1;
 FIG. 3 is a right view of the curved guiderail of FIG. 1;
 FIG. 4 is a rear view of the curved guiderail of FIG. 1;
 FIG. 5 is a front view of the curved guiderail of FIG. 1;
 FIG. 6 is bottom view of the curved guiderail of FIG. 1; and,
 FIG. 7 is a top view of the curved guiderail of FIG. 1.
 The conveyor guiderail is shown with a symbolic in its length. The appearance of any portion of the article between the break lines forms no part of the claimed design.
 The broken line depictions illustrate the environment of use, and form no part of the claimed design.

1 Claim, 2 Drawing Sheets

Related U.S. Application Data

- (63) Continuation of application No. PCT/US2018/033665, filed on May 21, 2018.
- (51) **LOC (13) CL.** **12-05**
- (52) **U.S. CL.**
USPC **D34/29; D34/35**
- (58) **Field of Classification Search**
USPC D34/28, 35, 29; D23/267; D6/580;
D25/35, 199; D26/85, 120; 198/502.01,
198/781.06, 810.01, 836.3, 836.1, 837,
198/861.1, 860.1
CPC .. B07B 1/4645; B65G 21/2072; B65G 47/26;
B65G 47/263; B65G 43/04; B65G 43/00;
B65G 21/00; B65G 21/20; B65D 17/00
See application file for complete search history.

(56) **References Cited**

U.S. PATENT DOCUMENTS

308,312 A * 11/1884 Gardner E04F 19/02
52/716.1
1,208,481 A * 12/1916 Cathcart B65G 21/2072
403/306
1,556,723 A 10/1925 Shaffer et al.
2,039,398 A * 5/1936 Dye Edward R B27M 3/004
52/847

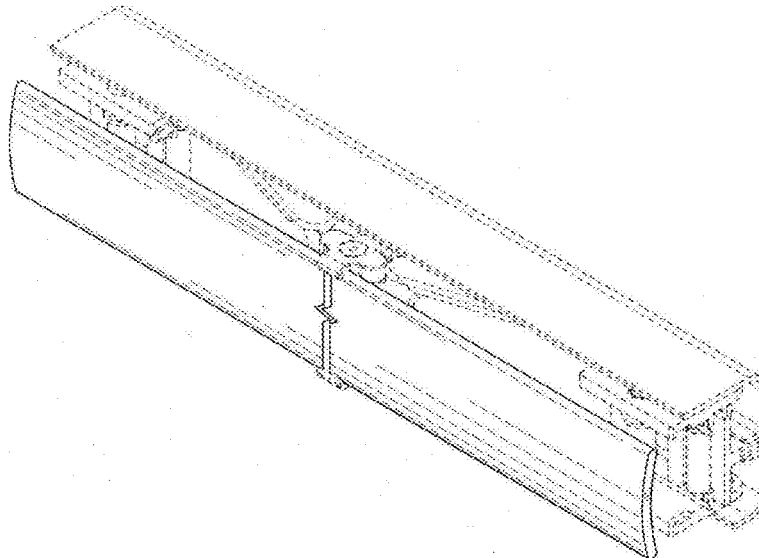

US D910,959 S

(56)	References Cited		6,044,602 A *	4/2000	Canavan	E04B 7/12 52/200
	U.S. PATENT DOCUMENTS		D433,782 S	11/2000	Carter	
			D448,494 S *	9/2001	Williams	D25/119
2,300,545 A *	11/1942	Gouch	6,328,154 B1 *	12/2001	Huber	B64D 9/00 198/781.06
		E06B 9/386 160/178.1 R	6,475,130 B1 *	11/2002	Simmons	B31D 5/0047 493/464
D152,818 S *	2/1949	Nelson	D472,418 S *	4/2003	Gilmore	D6/580
2,507,937 A *	5/1950	Slavsky	6,588,578 B1 *	7/2003	Ernst	B65G 21/2072 198/502.1
		G09F 3/20 40/650	D479,885 S *	9/2003	O'Hagin	D25/143
D168,258 S *	11/1952	Friedman	6,612,426 B1 *	9/2003	Guerra	B65G 21/06 198/841
D179,294 S	11/1956	Hinchcliffe	6,619,367 B1 *	9/2003	Kawakita	E06B 9/28 160/172 R
2,889,907 A	6/1959	Sullivan et al.	6,619,473 B2	9/2003	Romeo	
2,897,947 A	8/1959	Krupp et al.	D481,575 S *	11/2003	Steinberg	D6/580
D189,147 S	11/1960	Hinchcliffe	D487,160 S *	2/2004	Forbis	D25/126
2,979,806 A	4/1961	Stanley et al.	D495,549 S *	9/2004	Yu	D6/577
3,042,742 A *	7/1962	Foster	D501,348 S *	2/2005	Yu	D6/577
		F21V 21/16 174/69	D504,524 S *	4/2005	Lookman	D25/119
3,110,066 A	11/1963	Ward et al.	6,889,823 B2	5/2005	DelaPorte	
3,146,874 A	9/1964	Megow et al.	D515,266 S	2/2006	Moe	
3,191,749 A	6/1965	Hawley et al.	D532,911 S *	11/2006	Gardner	D25/136
3,200,967 A	8/1965	Giuseppe et al.	7,302,894 B2	12/2007	Belanger et al.	
3,330,080 A *	7/1967	Grieb	D562,992 S	2/2008	Szczekocki	
		E04B 7/08 52/86	D568,573 S *	5/2008	Kamamoto	D34/29
D209,071 S	10/1967	Koch	D590,197 S *	4/2009	Shiue	D6/577
3,349,534 A *	10/1967	Wotherspoon	D594,623 S	6/2009	Felton	
		E04D 1/045 52/520	D617,521 S	6/2010	Swinderman	
3,507,379 A	4/1970	Johnston et al.	7,823,719 B2 *	11/2010	Jaksic	B65G 39/02 198/781.05
3,545,169 A	12/1970	Nash et al.	D636,501 S *	4/2011	Shanes	D25/139
3,776,350 A	12/1973	Tice	D660,461 S *	5/2012	Kotin	D25/119
3,843,182 A	10/1974	Walls et al.	D697,656 S *	1/2014	Sabernig	D26/122
3,897,869 A	8/1975	Michael	D698,583 S *	2/2014	Lin	D6/577
4,015,537 A	4/1977	Graef et al.	D699,050 S *	2/2014	Lin	D6/577
4,214,744 A	7/1980	Evans	D710,564 S	8/2014	Yang	
D259,552 S	6/1981	Lindfors	D740,514 S	10/2015	Peterson et al.	
4,273,239 A *	6/1981	Thwaites	D764,140 S	8/2016	Holzhaeuser	
		B65G 47/261 198/781.06	D771,277 S	11/2016	McCue et al.	
4,293,065 A *	10/1981	Dyer	D783,223 S	4/2017	Peterson et al.	
		B65G 47/261 198/781.06	D783,914 S	4/2017	Supthut	
4,330,057 A	5/1982	Binns	D789,643 S	6/2017	Pettinga	
4,406,360 A *	9/1983	Smith	D790,799 S	6/2017	Holzhaeuser	
		B65G 47/261 198/781.06	9,776,836 B2	10/2017	Spies et al.	
4,533,173 A	8/1985	Davis	D816,267 S	4/2018	Fornarelli	
4,582,192 A	4/1986	Rojlar	D828,946 S *	9/2018	McVey	D26/85
4,658,731 A	4/1987	Schumann	10,087,012 B1	10/2018	Layne	
4,791,453 A	12/1988	Koseki et al.	D837,347 S *	1/2019	Brochu	D23/267
4,930,621 A	6/1990	Brown	D868,499 S *	12/2019	Hsu	D6/580
D313,685 S	1/1991	Johansson et al.	10,544,619 B2 *	1/2020	Hall	B01J 23/26 D34/29
4,983,836 A	1/1991	Matoba et al.	D878,701 S *	3/2020	Specht	
4,989,721 A	2/1991	Ach	2003/0116410 A1	6/2003	Ledingham	
5,005,693 A *	4/1991	Fultz	2004/0035685 A1	2/2004	Fujiwara et al.	
		B65G 47/263 198/781.06	2006/0027347 A1	2/2006	Boehm et al.	
5,038,087 A *	8/1991	Archer	2007/0251803 A1 *	11/2007	Schill	B21D 51/2692 198/418.2
		E06B 9/88 160/310	2007/0295582 A1 *	12/2007	DePaso	B65G 17/24 198/837
5,042,644 A *	8/1991	Davis	2008/0092680 A1 *	4/2008	Kim	H01L 21/67748 74/89.31
		B65G 47/263 198/781.06	2008/0110731 A1 *	5/2008	Vestergaard	B65G 13/12 198/860.3
5,066,834 A	11/1991	Richter	2010/0044281 A1	2/2010	Johnson et al.	
5,074,407 A	12/1991	Brumby	2010/0059342 A1 *	3/2010	Willi	B65G 13/04 198/789
5,139,131 A	8/1992	Persson	2010/0206699 A1 *	8/2010	Petrovic	B65G 21/2072 198/836.3
5,150,655 A	9/1992	Sakai	2010/0258409 A1 *	10/2010	Kas	B65G 21/2054 198/836.1
5,161,670 A	11/1992	David	2015/0068871 A1 *	3/2015	Tachibana	G05B 19/042 198/502.1
5,201,910 A	4/1993	Sheeter	2016/0107841 A1 *	4/2016	Spaulding	B65G 27/32 198/502.1
5,211,278 A	5/1993	Mendenhall	2016/0161520 A1 *	6/2016	Pedrazzini	G01N 35/02 198/571
5,277,295 A	1/1994	Grecksch et al.				
5,287,956 A *	2/1994	Collins				
		B65G 47/263 198/781.04				
D355,092 S *	2/1995	Swopes				
5,501,156 A	3/1996	Richter				
D371,667 S	7/1996	Poole				
D376,460 S	12/1996	Isaia et al.				
D376,461 S	12/1996	Graf				
D381,177 S	7/1997	Patois et al.				
5,649,617 A *	7/1997	Fortenbery				
		B65G 47/263 198/781.03				
5,685,415 A	11/1997	East				
D409,869 S *	5/1999	Marusak				
5,947,361 A	9/1999	Berger				
5,954,186 A *	9/1999	Stroobandt				
		B65G 43/04 198/502.4				

(56)

References Cited

U.S. PATENT DOCUMENTS

2017/0342717 A1* 11/2017 Brochu E04D 13/076
2019/0062063 A1* 2/2019 Baek B65G 21/14
2019/0376833 A1* 12/2019 Merz B65G 47/28

OTHER PUBLICATIONS

Google search Aug. 14, 2020, https://www.alibaba.com/product-detail/E0-Glue-Wooden-LVL-Slat-Curved_62596752124.html?spm=a2700.7724857.normalList.47.56c74ce3viQ898, Glue wooden Slat (Year: 2020).*

Google search Aug. 14, 2020, https://www.alibaba.com/product-detail/Linyi-Bent-Curved-LVL-Wood-Bed_62392080092.html?spm=a2700.7724857.normalList.32.56c74ce3viQ898, Linyi Bent Curved Wood Bed Slat (Year: 2020).*

Google search Aug. 14, 2020, <https://cnxdsjwj.en.made-in-china.com/product/aBsESMTOAto/China-2-Curved-Slat-Ready-Made-Blinds.html>, 2" curved slat ready made blinds (Year: 2020).*

Google search Aug. 14, 2020, <https://www.slideways.com/collections/uhmw-guide-rails>, UHMW Guide Rails (Year: 2020).*

Google search Aug. 13, 2020, <http://www.extrusionprofiles.com/> (Year: 2020).*

Google search Aug. 14, 2020, <https://eagle-aluminum.com/product/stainless-steel-oval-1-x-075-half-oval/>, stainless steel oval 1" face (Year: 2020).*

Google search Oct. 7, 2020, <https://buymbs.com/p-2929-fypon-polyurethane-crown-moulding.aspx>, Fypon Polyurethane crown moulding (Year: 2020).*

Google search Oct. 7, 2020, <https://www.millwork.com/8-h-x-8-p-16-length-cove-moulding.html>, 8hX8p, 16 cove moulding (Year: 2020).*

* cited by examiner

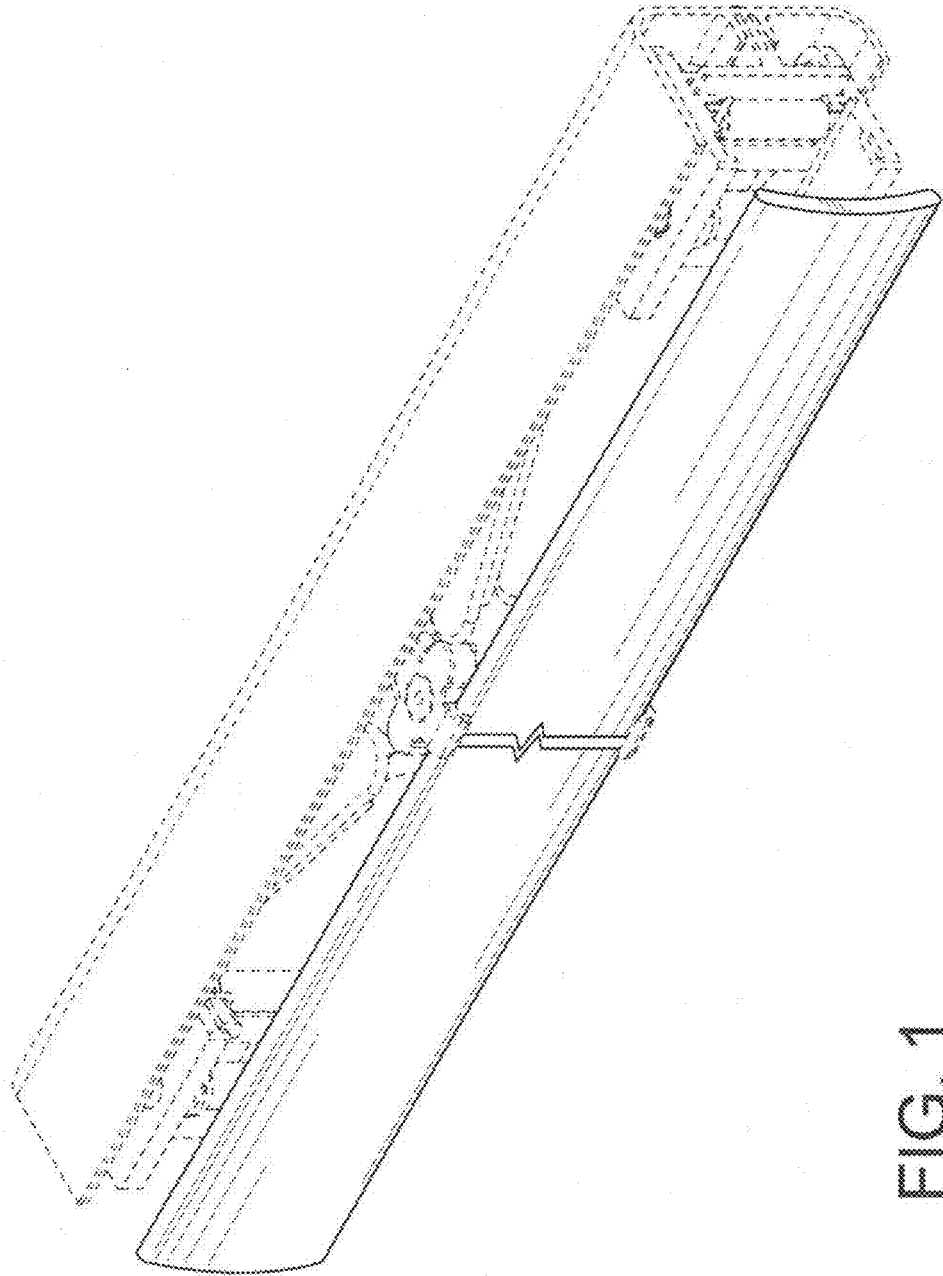

FIG. 1

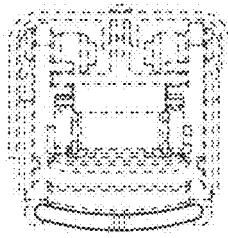

FIG. 5

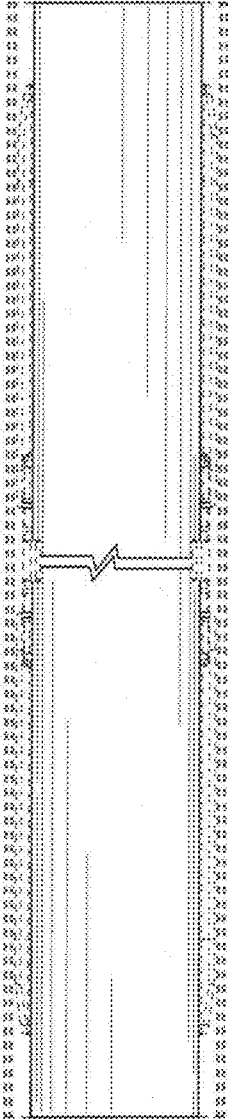

FIG. 2

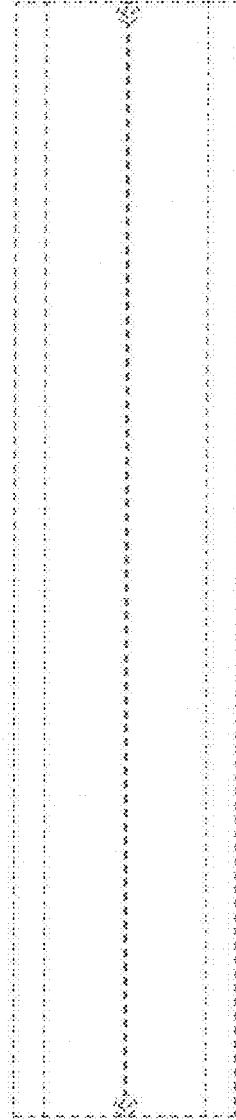

FIG. 4



FIG. 6

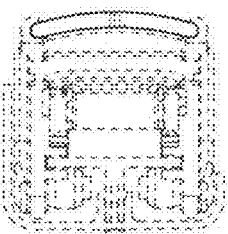

FIG. 3

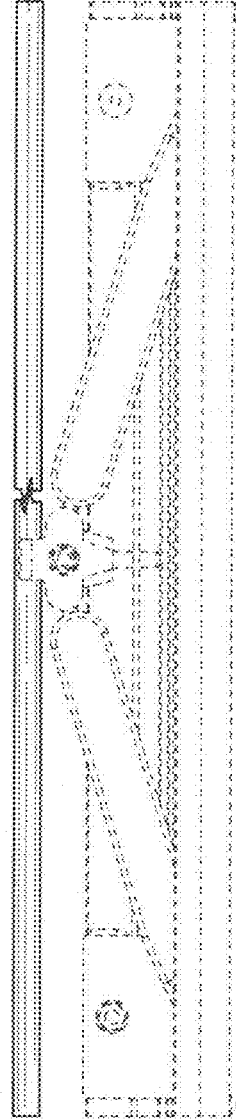

FIG. 7