



(51) International Patent Classification:

B60S 1/00 (2006.01) *B60S 1/32* (2006.01)
B60S 1/02 (2006.01) *B60S 1/38* (2006.01)
B60S 1/04 (2006.01) *B60S 1/40* (2006.01)

(21) International Application Number:

PCT/US2017/033640

(22) International Filing Date:

19 May 2017 (19.05.2017)

(25) Filing Language:

English

(26) Publication Language:

English

(30) Priority Data:

62/339,072 19 May 2016 (19.05.2016) US

(71) Applicant: **PYLON MANUFACTURING CORP.**

[US/US]; 600 West Hillsboro Boulevard, Suite 400, Deerfield Beach, FL 33441 (US).

(72) Inventor: **KAWASHIMA, Hiroshi**; 9904 NW 47th Street,

Sunrise, Florida 33351 (US).

(74) Agent: **SOBRADO, Javier** et al.; Cozen O'Connor, 1200

19th Street N.W., Third Floor, Washington, D.C. 20036 (US).

(81) Designated States (*unless otherwise indicated, for every kind of national protection available*):

AE, AG, AL, AM, AO, AT, AU, AZ, BA, BB, BG, BH, BN, BR, BW, BY, BZ, CA, CH, CL, CN, CO, CR, CU, CZ, DE, DJ, DK, DM, DO, DZ, EC, EE, EG, ES, FI, GB, GD, GE, GH, GM, GT, HN, HR, HU, ID, IL, IN, IR, IS, JP, KE, KG, KH, KN, KP, KR, KW, KZ, LA, LC, LK, LR, LS, LU, LY, MA, MD, ME, MG, MK, MN, MW, MX, MY, MZ, NA, NG, NI, NO, NZ, OM, PA, PE, PG, PH, PL, PT, QA, RO, RS, RU, RW, SA, SC, SD, SE, SG, SK, SL, SM, ST, SV, SY, TH, TJ, TM, TN, TR, TT, TZ, UA, UG, US, UZ, VC, VN, ZA, ZM, ZW.

(84) Designated States (*unless otherwise indicated, for every kind of regional protection available*):

ARIPO (BW, GH, GM, KE, LR, LS, MW, MZ, NA, RW, SD, SL, ST, SZ, TZ, UG, ZM, ZW), Eurasian (AM, AZ, BY, KG, KZ, RU, TJ, TM), European (AL, AT, BE, BG, CH, CY, CZ, DE, DK, EE, ES, FI, FR, GB, GR, HR, HU, IE, IS, IT, LT, LU, LV,

(54) Title: WINDSHIELD WIPER CONNECTOR

FIGURE 2

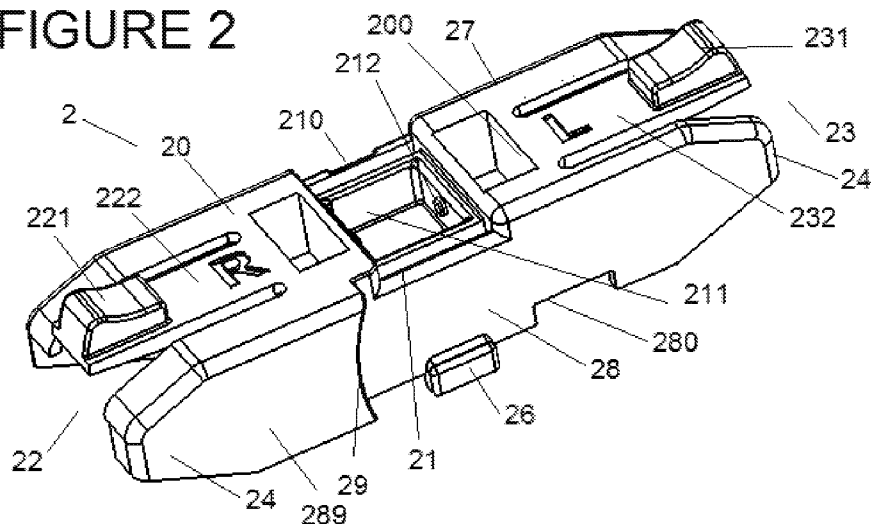

(57) Abstract: A connector assembly and wiper blade incorporating same having a base connector, having two longitudinal side walls, a first and second end, and a top surface extending therebetween, wherein the top surface has a pair of cantilevered beams, each provided with a locking tab, extending from a central portion towards each respective end of the base connector. The locking tabs are capable of engaging and securing an aperture in cap or wiper arm. The base connector further has a central recessed portion capable of receiving and securing a top wall of a side adapter. The base connector may further include a base support structure capable of securing the base connector to a wiper blade.



MC, MK, MT, NL, NO, PL, PT, RO, RS, SE, SI, SK, SM,
TR), OAPI (BF, BJ, CF, CG, CI, CM, GA, GN, GQ, GW,
KM, ML, MR, NE, SN, TD, TG).

Published:

— *with international search report (Art. 21(3))*

WINDSHIELD WIPER CONNECTOR

CROSS REFERENCE TO RELATED APPLICATIONS

[0001] This application claims the benefit of U.S. Provisional Application No. 62/339,072 filed May 19, 2016, the disclosure of which is hereby incorporated herein by reference in its entirety.

TECHNICAL FIELD

[0002] This invention relates in general to windshield wipers, and more particularly, to an improved connector for a windshield wiper that allows the windshield wiper to be attached to a top-lock windshield wiper arm. The invention is also directed to windshield wipers incorporating these novel connectors.

BACKGROUND OF THE DISCLOSURE

[0003] There are a variety of wiper arms on which wiper blades are provided as original equipment. These various wiper arms have hooks, pins, or other configurations which may connect to the wiper blade with or without connectors. These various configurations have created a problem in the replacement market because wiper blade providers are required to have multiple wiper blade configurations to accommodate all of the existing wiper arms. It is therefore advantageous to have attachment structures that can accommodate a host of arms to reduce the complexity and cost associated with this problem.

[0004] The need to attach replacement windshield wiper blades to multiple arms has been addressed to some degree. For example, windshield wiper blades have been designed to work with various hook-type wiper arms having different sizes. Connectors may also be configured to receive either a pin-type arm or a hook arm. While these connectors may increase the usefulness of a given windshield wiper such that it can be used with different wiper arm types, the connectors are often expensive and have a complicated structure that is difficult and time-consuming to manufacture

[0005] Thus, there is a need for inexpensive connectors that are capable of securing a windshield wiper blade to a variety of arms. It would also be desirable to have a windshield wiper connector that can be fabricated or molded as a single piece at low-cost, and that can accommodate a variety of wiper arms. The disclosed concepts provide a low-cost windshield wiper connector capable of attachment to a variety of windshield wiper arms for the purpose of reducing the

amounts of inventory parts required to supply a vehicle market that uses a wide variety of windshield wiper arm types.

SUMMARY OF THE DISCLOSURE

[0006] The following presents a simplified summary of the disclosure in order to provide a basic understanding of some aspects of the invention. This summary is not an extensive overview of every embodiment disclosed herein. It is intended to neither identify key or critical elements of the various embodiments nor delineate the scope of the disclosure. Its sole purpose is to present some concepts of the disclosure, in accordance with the various embodiments disclosed herein, in a simplified form as a prelude to the more detailed description that is presented later.

[0007] This disclosure is generally directed to novel connectors for windshield wiper blades. In certain embodiments, a connector assembly includes a base connector having two longitudinal side walls, a first and second end, and a top surface extending therebetween, wherein the top surface has a pair of cantilevered beams, each provided with a locking tab, extending from a central portion towards each respective end of the base connector. The locking tabs are capable of engaging and securing an aperture in cap or wiper arm. The base connector further has a central recessed portion capable of receiving and securing a top wall of a side adapter. The base connector may further include a base support structure capable of securing the base connector to a wiper blade. The disclosure is also directed to wiper blades incorporating the connector assemblies described herein.

BRIEF DESCRIPTION OF THE DRAWINGS

[0008] The following description and the annexed drawings set forth certain illustrative aspects of the embodiments of the disclosure. These aspects are indicative, however, of but a few of the various ways in which the principles of the disclosure may be employed and the various embodiments are intended to include all such aspects and their equivalents. Other advantages and novel features will become apparent from the following description when considered in conjunction with the drawings.

[0009] Figure 1 is a top perspective view of an embodiment of a connector assembly including embodiments of a base connector, a covering cap, and a side adapter of the disclosure.

[0010] Figure 2 top perspective view of the base connector shown in Figure 1.

- [0011] Figure 3 is a bottom perspective view of the base connector shown in Figure 1.
- [0012] Figure 4 is a top view of the base connector shown in Figure 1.
- [0013] Figure 5 is a bottom view of the base connector shown in Figure 1.
- [0014] Figure 6 is a side view of the base connector shown in Figure 1.
- [0015] Figure 7 is an opposing side view of the base connector shown in Figure 1.
- [0016] Figure 8 is a first end view of the base connector shown in Figure 1.
- [0017] Figure 9 is a second end view of the base connector shown in Figure 1.
- [0018] Figure 10 is a top perspective view of the connector shown in Figure 1 attached to a windshield wiper blade.
- [0019] Figure 11 is a top perspective view of a cap for the base connector shown in Figure 1.
- [0020] Figure 12 is a bottom perspective view of a cap for the base connector shown in Figure 1.
- [0021] Figure 13 is a top perspective view of the side adapter shown in Figure 1.
- [0022] Figure 14 is a bottom perspective view of the side adapter shown in Figure 1.
- [0023] Figure 15 is a top perspective view of the base connector, cap and side adapter connected to a wiper arm.
- [0024] Figure 16 is a top perspective view of the base connector, and side adapter shown in Figure 1 connected to a wiper arm.
- [0025] Figure 17 is a top perspective view of the base connector and cap shown in Figure 1 connected to a wiper arm.

DETAILED DESCRIPTION OF THE DISCLOSURE

[0026] The following detailed description and the appended drawings describe and illustrate some embodiments of the disclosure for the purpose of enabling one of ordinary skill in the relevant art to make and use these embodiments. As such, the detailed description and illustration of these embodiments are purely illustrative in nature and are in no way intended to limit the scope of the disclosure in any manner. It should also be understood that the drawings are not necessarily to scale and in certain instances details may have been omitted, which are not necessary for an

understanding of the embodiments, such as details of fabrication and assembly. In the accompanying drawings, like numerals represent like components.

[0027] In this document, the terms “a” or “an” are used, as is common in patent documents, to include one or more than one. In this document, the term “or” is used to refer to a nonexclusive or, unless otherwise indicated. Furthermore, references to “one embodiment” or “an embodiment” are not intended to be interpreted as explicitly excluding the existence of additional embodiments that also incorporate the recited features. Moreover, unless explicitly stated to the contrary, embodiments “comprising,” “including,” or “having” an element or a plurality of elements having a particular property may include additional such elements not having that property.

[0028] This disclosure is generally directed to novel connectors for windshield wiper blades. In certain embodiments, a connector assembly may have a base connector, having two longitudinal side walls, a first and second end, and a top surface extending therebetween. The top surface may have a pair of cantilevered beams, each provided with a locking tab, extending from a central portion towards each respective end of the base connector. The locking tabs may be capable of engaging and securing an aperture in cap or wiper arm. The base connector further may have a central recessed portion capable of receiving and securing a top wall of a side adapter. The base connector may further include a base support structure capable of securing the base connector to a wiper blade. The invention is also directed to wiper blades incorporating the connector assemblies described herein.

[0029] In certain embodiments, the side walls of the base connector may include rests which are capable of supporting a wiper arm when the connector assembly is secured to a wiper arm. In certain embodiments, the side walls may also have an extended portion such that the base connector has a greater width (i.e. distance between the side walls) at one end than at the other end. In certain embodiments, the base connector may further have wings along side at least one of the cantilevered beams, such that grooves are formed between the wings and the cantilevered beams.

[0030] In certain embodiments, the base connector may further have a bottom support structure that comprises internal side walls having arcuate rivet clips that are capable of securing the rivet of a mounting base of a wiper blade. In certain embodiments, the bottom support structure may further have transverse lateral walls which extend between and connect the internal side walls.

[0031] In certain embodiments, the base connector may further have a cavity provided with projections that are capable of engaging and securing recesses in flaps of a side adapter. In certain embodiments, the side walls may further have a bottom recesses that are capable of receiving and securing a bottom projection in a side adapter.

[0032] In certain embodiments, the connector assembly may further be provided with a side adapter having a top portion and a side wall. In certain embodiments, the top portion may be provided with flaps having recesses which are capable of engaging the projections in the cavity of the base connector. In certain embodiments, the side adapter may further have a side wall with a bottom projection which engages the bottom recess of the base connector. In certain embodiments, the side adapter may further have a rest which abuts the rest of at least one of the side walls of the base connector, and which is capable of supporting a wiper arm when the connector assembly connects to a wiper arm.

[0033] In certain embodiments, the connector assembly may also be provided with a cap having an aperture which can engage and secure one of the locking tabs of the base connector. In certain embodiments, the cap may further have channeling ribs which slidably engage the groove between the cantilevered beam and the wings on one of the ends of the base connector. In certain embodiments, the cap may further have claws which engage the bottom of the side walls of the base connector. In certain embodiments, the cap may further have spacers which maintain a gap between the cap and the ends of the wings or top surface of the base connector.

[0034] In certain embodiments, the connector may further include a cap having an aperture which can engage and secure at least one of the locking tabs of the base connector. In certain embodiments, the cap may further include channeling ribs which slidably engage the groove between the cantilevered beam and the wings on one of the ends of the base connector. In certain embodiments, the cap may further include claws which engage the bottom of the side walls of the base connector. In certain embodiments, the cap may further include spacers which maintain a gap between the cap and the ends of the wings or top surface of the base connector.

[0035] In certain embodiments, a wiper blade assembly may include a wiper strip, a force distribution structure, and a connector assembly. The connector assembly may include a base connector, having two longitudinal side walls, a first and second end, and a top surface extending therebetween. The top surface may include a pair of cantilevered beams, each provided with a

locking tab, extending from a central portion of the top surface towards each respective end of the base connector. The locking tabs may be capable of engaging and securing an aperture in cap or wiper arm. A central recessed portion may be capable of receiving and securing a top wall of a side adapter, and a base support structure may be capable of securing the base connector to a wiper blade.

[0036] In certain embodiments the connector assembly may further include wings alongside at least one of the cantilevered beams, such that grooves are formed between the wings and the cantilevered beams. In certain embodiments, the base support structure may include internal side walls having arcuate rivet clips that are capable of securing the rivet of a mounting base of a wiper blade, and transverse lateral walls which extend between and connect the internal side walls. Certain embodiments may further include a side adapter having a top portion and a side wall; the top portion comprising flaps having recesses which are capable of engaging projections in a cavity of the base connector. In certain embodiments, the connector assembly may include a cap having an aperture which can engage and secure at least one of the locking tabs of the base connector.

[0037] Figure 1 illustrates a top perspective view of an embodiment of a connector assembly 1 of the disclosure. The connector assembly 1 may be designed to connect to numerous types of top-lock wiper arms, as shown in Figures 15-17. The connector assembly 1 may have a base connector 2, a cap 3, and a side adapter 4.

[0038] Figures 2-9 illustrate various views of the base connector 2 of the connector assembly 1. The base connector 2 may have a first end 22 and a second end 23. The base connector may further have a first longitudinal side wall 27, and a second longitudinal side wall 28. One or both of the longitudinal side walls may have an extended first portion 289 which extends laterally outward from the respective side wall 28. A shelf 29 facing towards second end 23 may be provided between the extended first portion 289 and the side wall 28. Shelf 29 may be shaped to complement the shape of the end of a wiper arm 5, and the shape of the side adapter 4. The side walls 27, 28 may further be provided with rests 26, which receive and support the bottom of a wiper arm 5 and/or a side adapter 4. The side walls 28 may further be provided with bottom recess 280 which receives and secures a bottom projection 480 in the wall 48 of the side adapter 4.

[0039] A top surface 20 may extend between opposing peripheral side walls 27, 28. The top surface may be provided with a pair of cantilevered beams 222, 232. The cantilevered beams may extend from the center portion of the base connector 2 towards respective first and second ends 22, 23. Each cantilevered beam 222, 232 may further be provided with a locking tab 221, 231. The locking tabs may engage apertures 31, in either the cap 3 or in a top-lock wiper arm 5, to secure the base connector 2 to same. As shown in Figure 5, the bottom of the cantilevered beams 222, 232 may further be provided with hollowed recesses 223, 233 underneath the locking tabs 221, 231. The cantilevered beams 222, 232 may extend between wings 24 on either ends 22, 23 of the base connector 2. The cantilevered beams 222, 232 may be separated from the wings 24 by grooves. The bottom of the cantilevered beams 222, 232 may further be provided with reinforcing ribs 224, 234. Top recesses 200 may be provided in the top surface 20 of the base connector 2. These top recesses 200 may be sized and shaped to receive a tongue (not shown) extending from a top-lock wiper arm.

[0040] The top surface 20 may further be provided with a central recessed portion 21 which may be sized and shaped to accommodate side adapter 4. The central recessed portion 21 may further be provided with a cavity 211 having projections 212. The cavity 211 may receive and secure flaps 42 by having the projections 212 engage securing recesses 41 in the flaps 42. The projections 212 and securing recesses 41 may have complementary shapes that engage and secure one another. Persons of skill in the art will recognize that the projections and recesses may be swapped such that the projections are on the flaps 42 of the side adapter 4, and the recesses are in the walls of the cavity 211. Any other suitable method of securing the top wall 40 of the side adapter 4 to the central recessed portion 21 of the base connector 2 may also be practiced within the disclosed concepts. The central recess portion 21 may also be provided with notch 210 to facilitate the separation of the base connector 2 from the side adapter 4 via the use of a tool, or a person's finger nail.

[0041] As shown in Figure 10, the base connector 2 may be mounted on and secured to the mounting base of a wiper blade 6 via the rivet clips 201, 202, or via any other known method of pivotally securing a connector to a wiper blade known in the art. The base connector 2 can be used to connect a wiper arm alone, or with the cap 3, and/or the side adapter 4. In certain embodiments, the connector assembly 1 or base connector 2 may be connected to the wiper blade 6 prior to connecting to the wiper arm 5. In certain embodiments, the connector assembly 1 or base

connector 2 may be connected to the wiper arm 5 prior to being connected to the wiper blade 6. In certain embodiments, the connector assembly 1 may either be first connected to the wiper blade 6 or to the wiper arm 5. The wiper blade 6 may be a traditional wiper blade having a plurality of tournament-style brackets. Alternatively the wiper blade 6 may be a beam blade, such that the force from the wiper arm 5 is distributed along the wiper blade 6 by one or more spring-elastic beams. Alternatively, the wiper blade 6 may be a hybrid blade comprising one or more spring elastic beams, and one or more brackets. Persons of ordinary skill in the art will recognize that the disclosed concepts may be practiced with any wiper blade known in the art.

[0042] Figures 11 and 12 illustrate a cap 3 in accordance with the disclosed concepts. The cap 3 may have a top surface 30, a first end 32 and a second end 33, side walls 37, 38, and a contoured back edge 39. The side walls 37, 38 are preferably sized and shaped to receive the first or second ends 22, 23 of the base connector. A connector assembly 1 may be provided with a cap 3 for each end. The contoured edge 39 may be provided with a shape that is complementary to the shelf 29 of the base connector 2, and may be located adjacent to same when the cap 3 is engaged with and secured to the base connector 2.

[0043] The cap 3 may further be provided with an aperture 31, spacers, 305, 35, bottom claws 36, and channeling ribs 301. The aperture 31 may receive and secure the locking tabs 221, 231 of the base connector. The claws 36 may support and secure the bottoms of the longitudinal side walls 27, 28, 289 when the cap 3 is engaged with and secured to the base connector 2. The channeling ribs 301 may be sized to enter and slidably engage the grooves between the cantilevered beams 222, 232 and the wings 24. The spacers 35, 305 may be sized to leave a margin between the ends of the wings 24 and/or the top surface 20 of the base connector 2.

[0044] Figures 13 and 14 illustrate the side adapter 4 in accordance with the disclosed concepts. The side adapter may have a top wall, a side wall 48 a rest 46 and an end wing 44. The side wall 48 may be provided with internal ribs 45 for structural strength and support, and with an internal projection 480 which may engage bottom recess 280 in a side wall 28 of the base connector 2. One or more rests 46 may be provided on the bottom of side wall 48, and these rests may correspond to, and be disposed adjacent to the rests 26 in the side walls 27, 28 of the base connector 2 when the side adapter 4 is connected to the base connector 2.

[0045] The side adapter has a top wall 40 having flaps 42 with securing recesses 41. As discussed above, the securing recesses 41 may be sized and shaped to receive and secure projections 212 in the cavity 211 of the base connector 2. The projections and securing recesses may be swapped between the cap 3 and the base connector 2, and any other known method for securing the adapter to the base connector known in the art may be used in accordance with the disclosed concepts. The side adapter 4 may further be provided with a notch 400 that may align with the notch 210 in the recessed central portion 21 of the base connector. The notches may facilitate separation of the side adapter 4 from the base connector 2 via the use of a tool, or a person's fingernail.

[0046] Figures 15-17 illustrate different wiper arms connecting to the connector assembly in different configurations. In Figure 15, the base connector 2, cap 3, side adapter 4 are all used to connect to the wiper arm 5, such that the wiper arm 5 is supported by the rests 26, 46 of the base connector 2 and side adapter 4, and the locking tab 231 of the second end 23 of the base connector 2 engages and secures an aperture in the wiper arm. Figure 16 shows a similar, but reversed, arrangement where the wiper arm 5 engages the locking tab 221 of the first end 22 of the base connector 2, and the second end 23 of the base connector and wing 44 of the side adapter 4 can be seen. A cap 3 may be provided that can cover and secure the end of the connector assembly 1 in this configuration. Figure 17 shows the connector assembly 1 connecting to a narrower wiper arm 5 using only the base connector 2 and the cap 3 of the disclosed concepts. The side adapter 4 is removed from the connector assembly in the embodiment depicted in Figure 17. Similarly, Figures 15, 16, and 17 illustrate that the rests 26, 46 in the base connector 2 and/or side adapter 4 may serve as stops which abut claws on the wiper arm 5 to properly position the connector assembly relative to the wiper arm 5. Persons of skill in the art will recognize that the disclosed concepts can be implemented in a variety of different ways to connect to top-lock wiper arms of different shapes and sizes.

[0047] Those skilled in the art will recognize that while the invention will most likely be used in conjunction with automobiles, it is suitable for use with any vehicle. For example, in addition to automobiles, trucks, buses, locomotives, aircrafts, or any other vehicle type that uses a windshield wiper can benefit from the invention.

[0048] While specific embodiments have been discussed to illustrate the invention, it will be understood by those skilled in the art that the descriptions herein are intended as illustrative, and not as limiting, and that variations in the embodiments can be made without departing from the spirit of the invention.

[0049] For example, any suitable material can be used to manufacture the connector. The number or position of the locking tabs, guide pins, or other mechanisms can vary so long as they are capable of performing their intended function.

[0050] The descriptions set forth above are meant to be illustrative and not limiting. Various modifications of the embodiments, in addition to those described herein, will be apparent to those skilled in the art from the foregoing description. Such modifications are also intended to fall within the scope of the concepts described herein. Each patent, patent application and publication cited or described in this document are hereby incorporated herein by reference, in their entireties.

[0051] The foregoing description of possible implementations consistent with the present disclosure does not represent a comprehensive list of all such implementations or all variations of the implementations described. The description of some implementation should not be construed as an intent to exclude other implementations. For example, artisans will understand how to implement the embodiments in many other ways, using equivalents and alternatives that do not depart from the scope of the disclosure. Moreover, unless indicated to the contrary in the preceding description, none of the components described in the implementations are essential to the embodiments disclosed. It is thus intended that the embodiments be considered as illustrative, with a true scope and spirit of the disclosure being indicated by the following claims.

We claim:

1. A connector assembly comprising:
a base connector, having two longitudinal side walls;
a first and second end, and a
top surface extending therebetween; wherein the top surface comprises a pair of cantilevered beams, each provided with a locking tab, extending from a central portion of the top surface towards each respective end of the base connector; wherein the locking tabs are capable of engaging and securing an aperture in a cap or a wiper arm;
a central recessed portion capable of receiving and securing a top wall of a side adapter;
and
a base support structure capable of securing the base connector to a wiper blade.
2. The connector assembly of claim 1 where in the side walls of the base connector further comprise rests which are capable of supporting a wiper arm when the connector assembly is secured to a wiper arm.
3. The connector assembly of claim 1 wherein the side walls further comprise an extended portion such that the base connector has a greater width (defined as distance between the side walls) at one end than at the other end.
4. The connector assembly of claim 1 further comprising wings alongside at least one of the cantilevered beams, such that grooves are formed between the wings and the cantilevered beams.
5. The connector assembly of claim 1 wherein the base support structure comprises internal side walls having arcuate rivet clips that are capable of securing the rivet of a mounting base of a wiper blade.
6. The connector assembly of claim 5 wherein base support structure further comprises transverse lateral walls which extend between and connect the internal side walls.
7. The connector of assembly claim 1 wherein the base connector comprises a cavity provided with projections that are capable of engaging and securing recesses in flaps of a side adapter.

8. The connector of assembly claim 1 wherein the side walls further comprise a one or more bottom recesses that are capable of receiving and securing a bottom projection in a side adapter.
9. The connector of assembly claim 1 further comprising assembly may further be provided with a side adapter having a top portion and a side wall; the top portion comprising flaps having recesses which are capable of engaging projections in a cavity of the base connector.
10. The connector of assembly claim 9 wherein the side adapter further comprises a side wall with a bottom projection which engages a bottom recess of the base connector.
11. The connector of assembly claim 9 wherein the side adapter further comprises a rest which abuts the rest of at least one of the side walls of the base connector, and which is capable of supporting a wiper arm when the connector assembly connects to the wiper arm.
12. The connector assembly of claim 1 further comprising a cap having an aperture which can engage and secure at least one of the locking tabs of the base connector.
13. The connector assembly of claim 12 wherein the cap further comprises channeling ribs which slidably engage the groove between the cantilevered beam and the wings on one of the ends of the base connector.
14. The connector assembly of claim 12 wherein the cap further comprises claws which engage the bottom of the side walls of the base connector.
15. The connector assembly of claim 12 wherein the cap further comprises spacers which maintain a gap between the cap and the ends of the wings or top surface of the base connector.
16. A wiper blade assembly comprising
 - a wiper strip;
 - a force distribution structure; and
 - a connector assembly comprising:
 - a base connector, having two longitudinal side walls;
 - a first and second end, and a
 - top surface extending therebetween; wherein the top surface comprises a pair of cantilevered beams, each provided with a locking tab, extending from a central

portion of the top surface towards each respective end of the base connector;
wherein the locking tabs are capable of engaging and securing an aperture in a cap
or a wiper arm;

a central recessed portion capable of receiving and securing a top wall of a side adapter;
and

a base support structure capable of securing the base connector to a wiper blade.

17. The wiper blade assembly of claim 16 wherein the connector assembly further comprises wings alongside at least one of the cantilevered beams, such that grooves are formed between the wings and the cantilevered beams.

18. The wiper blade assembly of claim 16 wherein the base support structure comprises internal side walls having arcuate rivet clips that are capable of securing the rivet of a mounting base of a wiper blade, and transverse lateral walls which extend between and connect the internal side walls.

19. The wiper blade of assembly claim 16 further comprising a side adapter having a top portion and a side wall; the top portion comprising flaps having recesses which are capable of engaging projections in a cavity of the base connector.

20. The wiper blade assembly of claim 16 further comprising a cap for the connector assembly, the cap having an aperture which can engage and secure at least one of the locking tabs of the base connector.

FIGURE 1

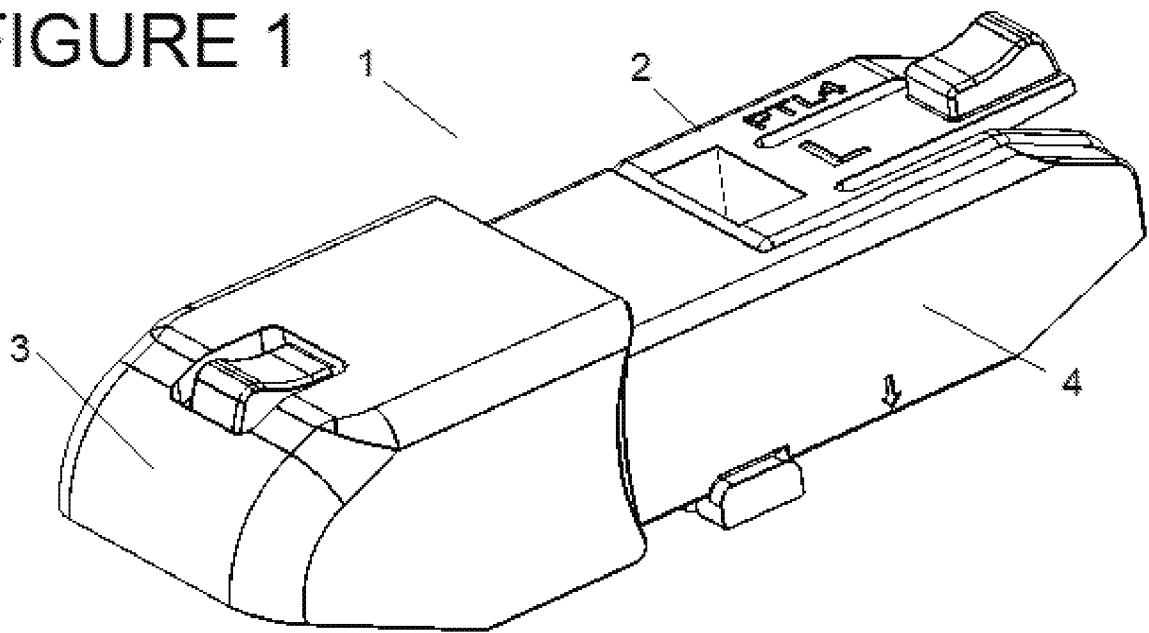

FIGURE 2

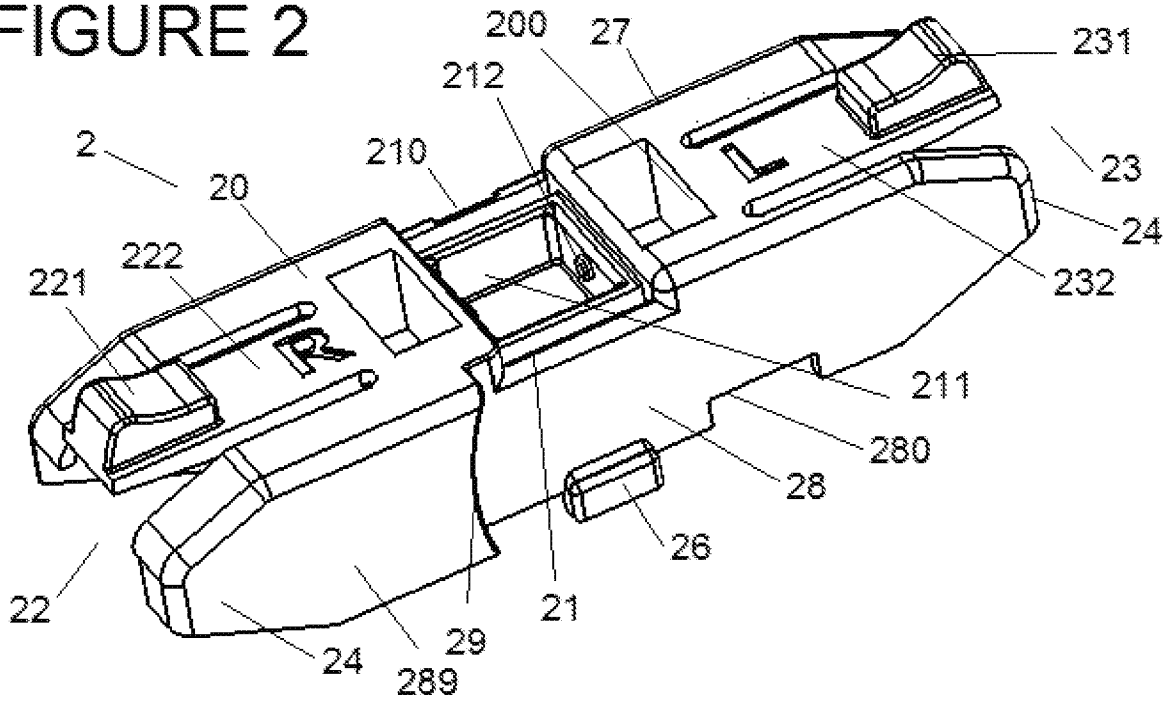

FIGURE 3

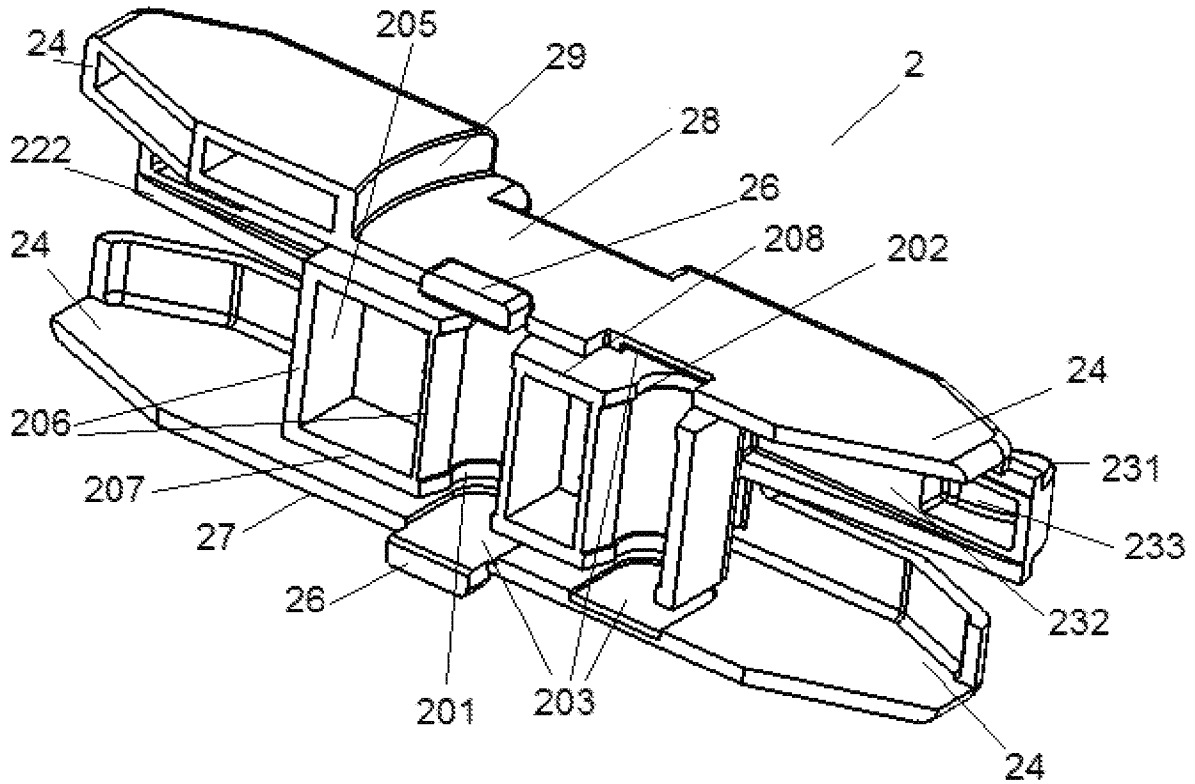

FIGURE 4

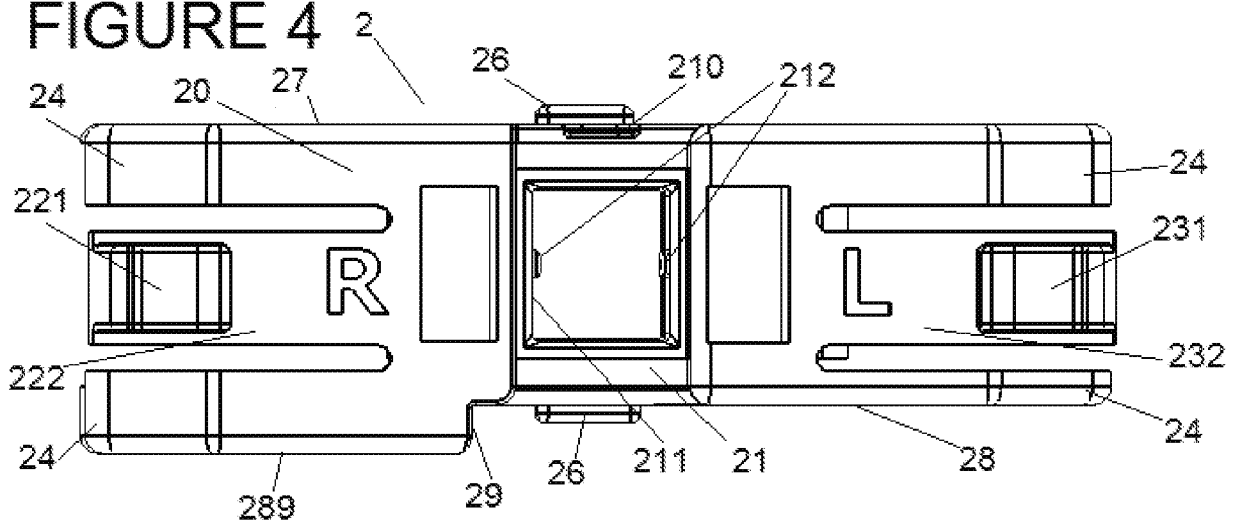

FIGURE 5

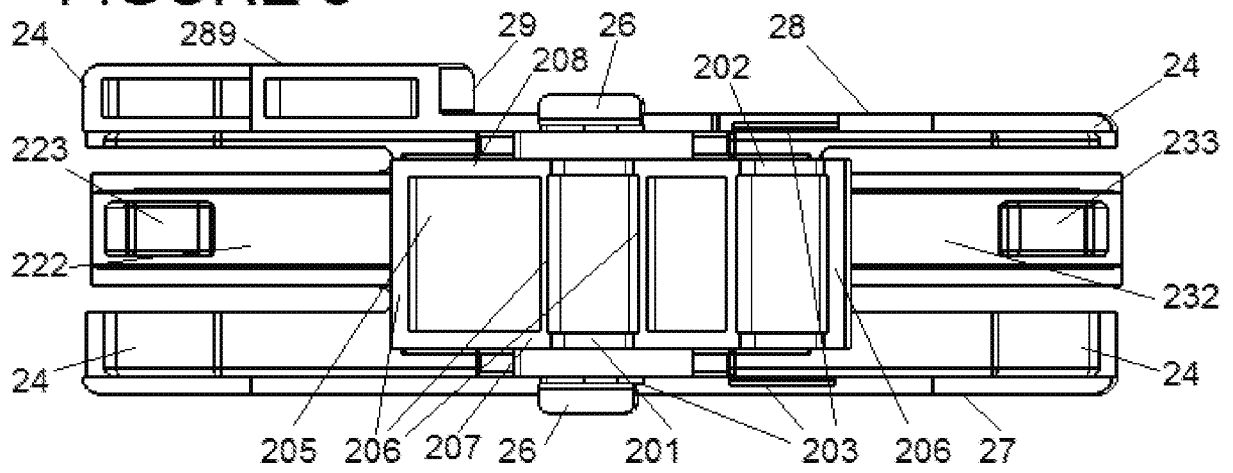

FIGURE 6

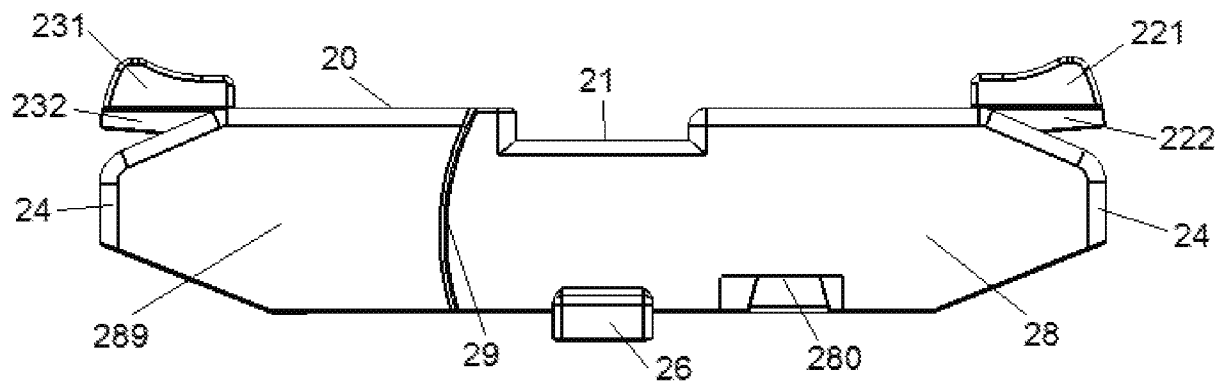

FIGURE 7

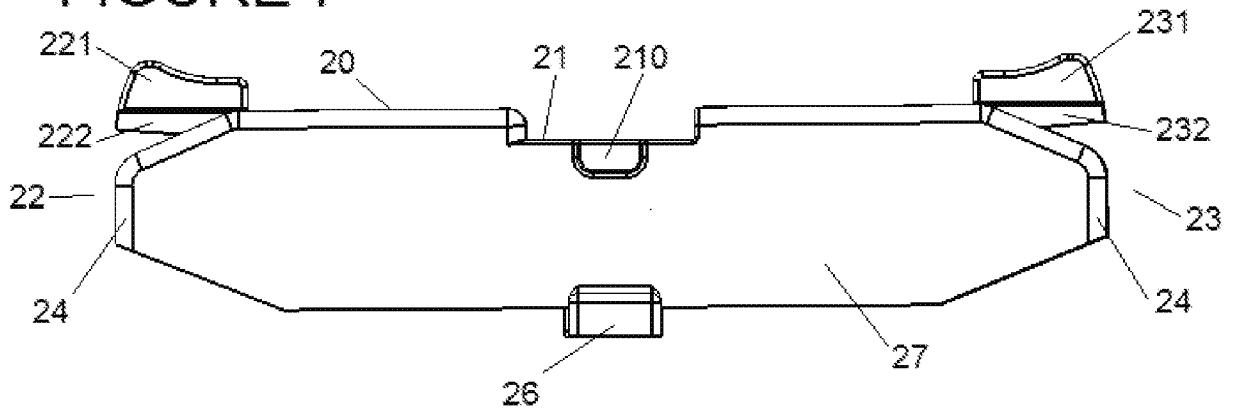

FIGURE 8

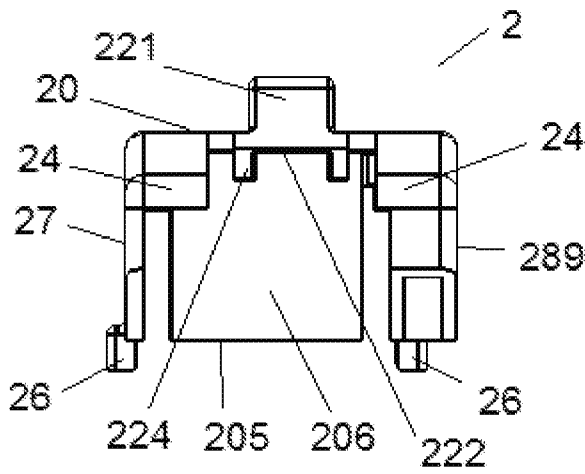

FIGURE 9

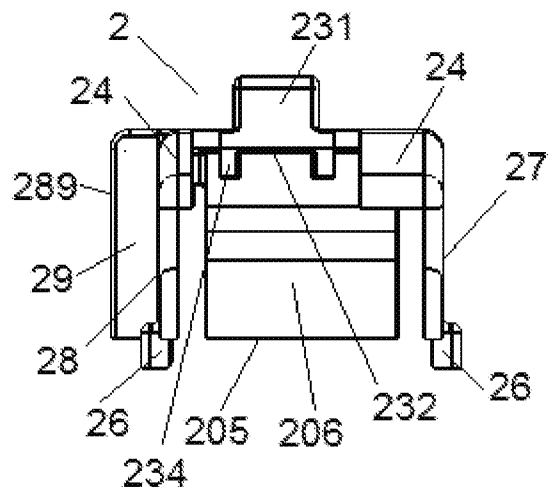

FIGURE 10

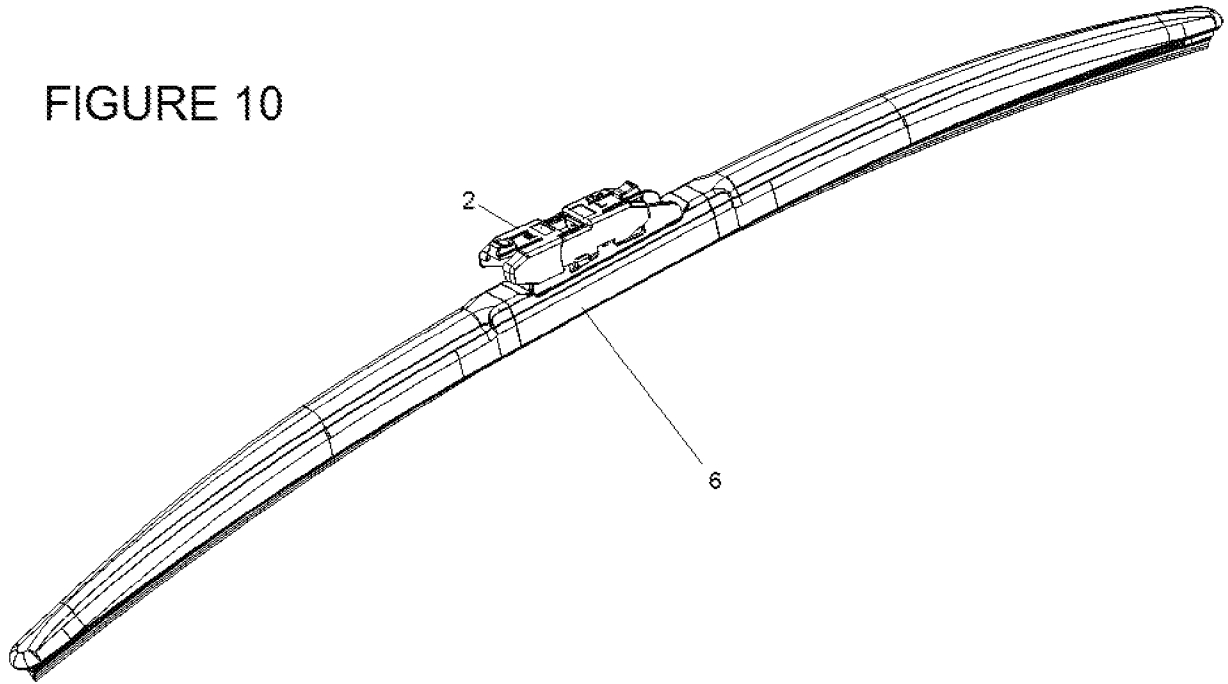

FIGURE 11

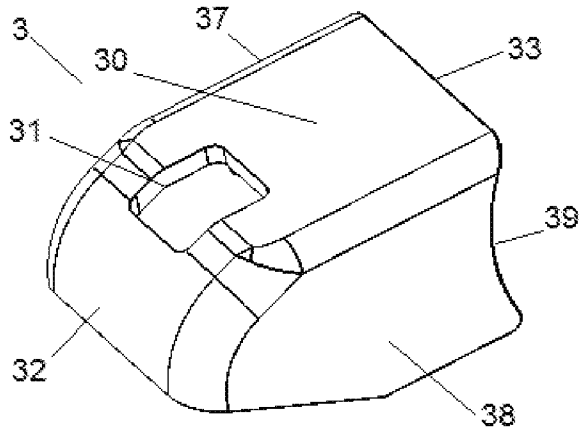

FIGURE 12

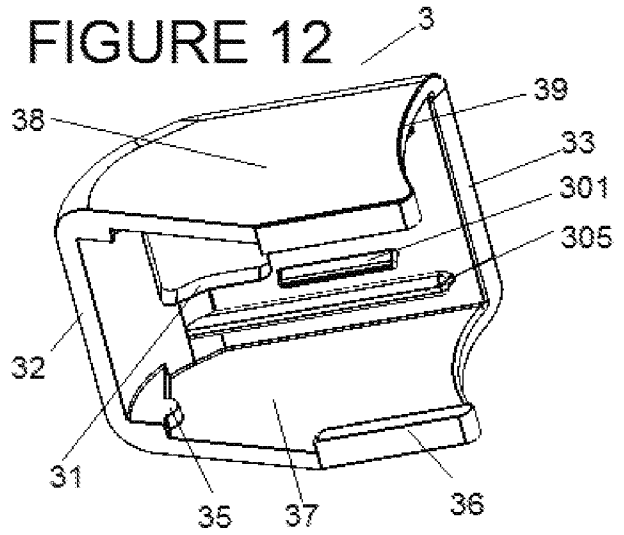

FIGURE 13

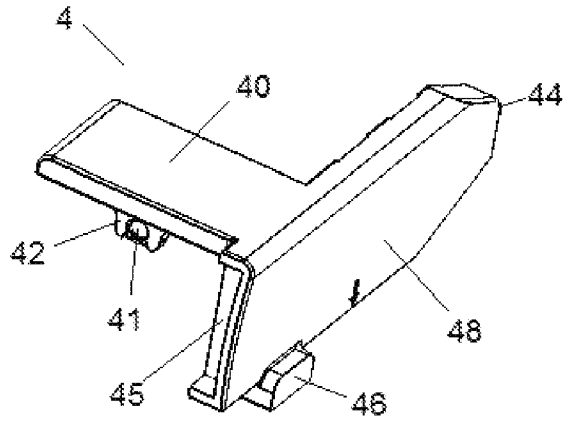

FIGURE 14

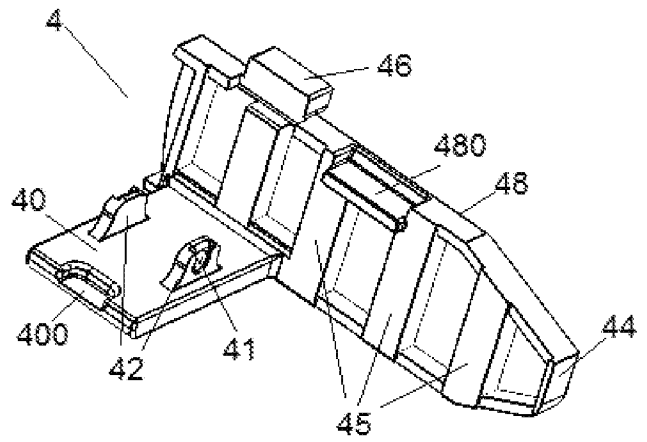

FIGURE 15

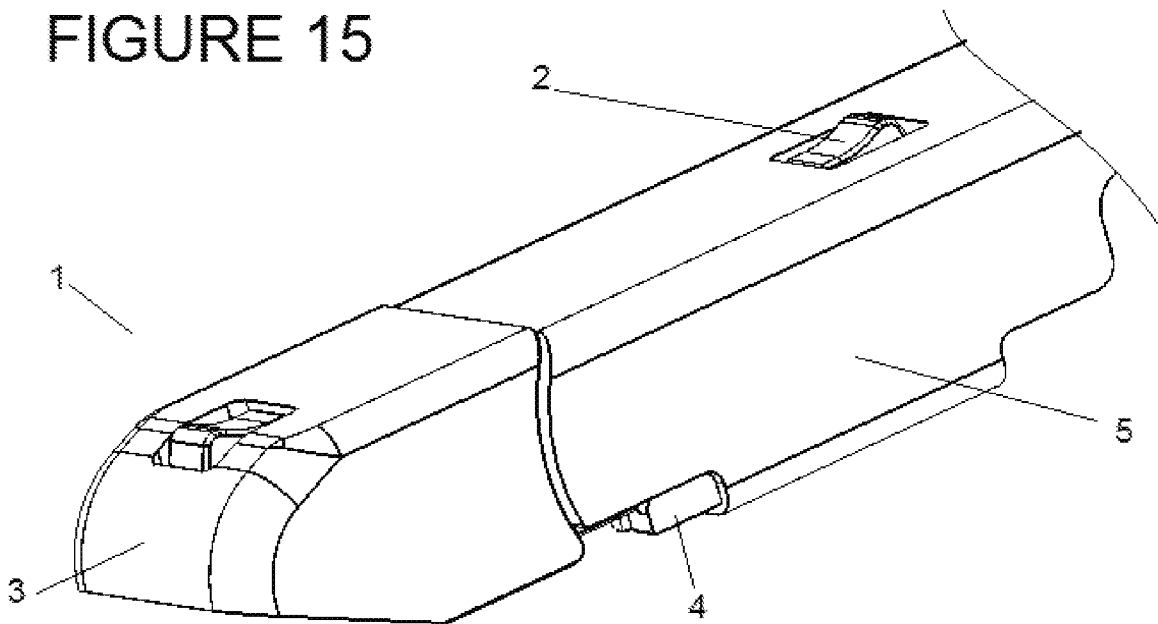

FIGURE 16

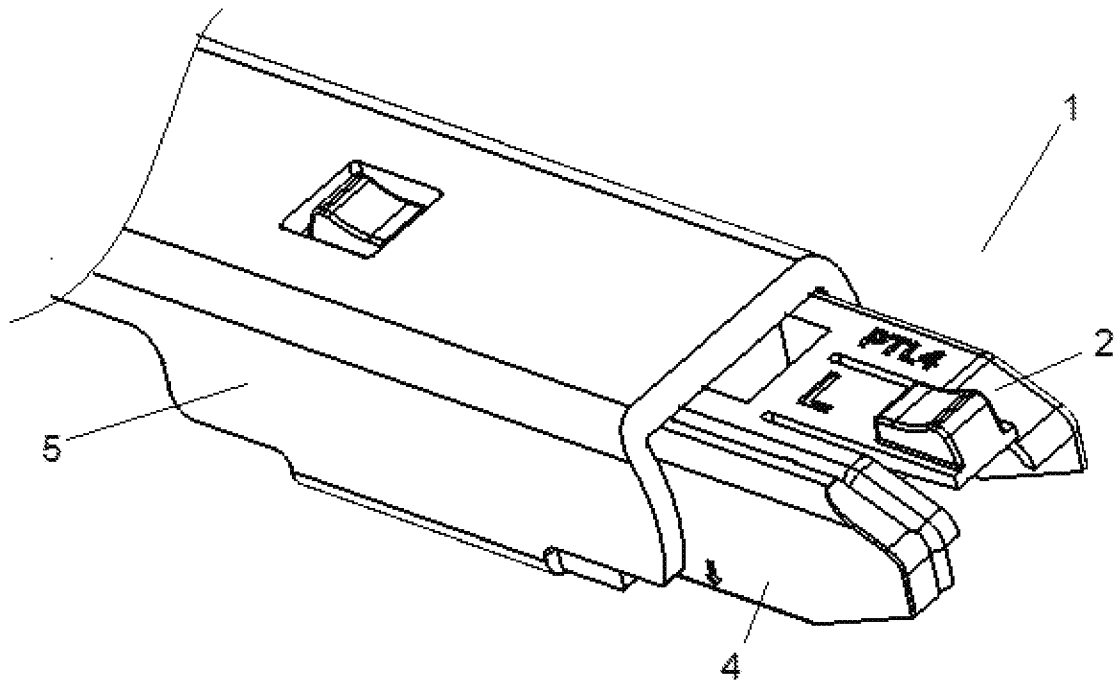

FIGURE 17

