



- (51) **International Patent Classification:**
A61B 18/18 (2006.01)
- (21) **International Application Number:**
PCT/US2009/066133
- (22) **International Filing Date:**
30 November 2009 (30.11.2009)
- (25) **Filing Language:** English
- (26) **Publication Language:** English
- (30) **Priority Data:**
12/337,232 17 December 2008 (17.12.2008) US
- (71) **Applicant (for all designated States except US):** THE SPECTRANETICS CORPORATION [US/US]; 96 Talamine Court, Colorado Springs, Colorado 80907 (US).
- (72) **Inventors; and**
- (75) **Inventors/Applicants (for US only):** TAYLOR, Kevin, D. [US/US]; 14715 East Coachman Drive, Colorado Springs, Colorado 80908 (US). BOWE, Wade [US/US]; 11871 Cloudy Creek Ct, Colorado Springs, Colorado 80921 (US).
- (74) **Agents:** GIBBY, Darin, J. et al.; Townsend and Townsend and Crew LLP, 1400 Wewatta St, Suite 600, Denver, Colorado 80202 (US).

- (81) **Designated States (unless otherwise indicated, for every kind of national protection available):** AE, AG, AL, AM, AO, AT, AU, AZ, BA, BB, BG, BH, BR, BW, BY, BZ, CA, CH, CL, CN, CO, CR, CU, CZ, DE, DK, DM, DO, DZ, EC, EE, EG, ES, FI, GB, GD, GE, GH, GM, GT, HN, HR, HU, ID, IL, IN, IS, JP, KE, KG, KM, KN, KP, KR, KZ, LA, LC, LK, LR, LS, LT, LU, LY, MA, MD, ME, MG, MK, MN, MW, MX, MY, MZ, NA, NG, NI, NO, NZ, OM, PE, PG, PH, PL, PT, RO, RS, RU, SC, SD, SE, SG, SK, SL, SM, ST, SV, SY, TJ, TM, TN, TR, TT, TZ, UA, UG, US, UZ, VC, VN, ZA, ZM, ZW.
- (84) **Designated States (unless otherwise indicated, for every kind of regional protection available):** ARIPO (BW, GH, GM, KE, LS, MW, MZ, NA, SD, SL, SZ, TZ, UG, ZM, ZW), Eurasian (AM, AZ, BY, KG, KZ, MD, RU, TJ, TM), European (AT, BE, BG, CH, CY, CZ, DE, DK, EE, ES, FI, FR, GB, GR, HR, HU, IE, IS, IT, LT, LU, LV, MC, MK, MT, NL, NO, PL, PT, RO, SE, SI, SK, SM, TR), OAPI (BF, BJ, CF, CG, CI, CM, GA, GN, GQ, GW, ML, MR, NE, SN, TD, TG).

Published:

- with international search report (Art. 21(3))

- (54) **Title:** RAPID EXCHANGE BIAS LASER CATHETER DESIGN

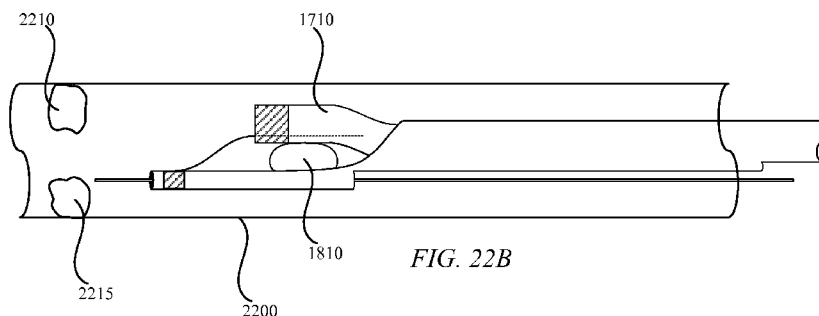

- (57) **Abstract:** Embodiments of a balloon biasing laser catheter are provided. In some embodiments, the laser catheter may include a distal tip that extends from the distal end of the catheter from a point near the light guide aperture. The distal tip may be disposed at the periphery of the catheter. In some embodiments, a balloon may be disposed between the light guide aperture and the distal tip, such that the light guide extending from the aperture may be disposed proximate with the distal tip having the balloon in between. A retaining wire may be coupled with the distal tip and slidably coupled with the light guide. The retaining wire may keep the light guide biased relatively parallel with the distal tip and/or the catheter body when the balloon is inflated. The light guide may include a guidewire lumen the extends to the distal end of the distal tip.

WO 2010/071737 A1

RAPID EXCHANGE BIAS LASER CATHETER DESIGN

CROSS-REFERENCES TO RELATED APPLICATIONS

[0001] This application is a continuation in part of U.S. Non-Provisional Application Serial
5 No. 11/228,845 filed on September 16, 2005, which claims the benefit of U.S. Provisional
Application Serial No. 60/611,191 filed September 17, 2004, which is hereby incorporated by
reference in its entirety.

TECHNICAL FIELD

[0002] The embodiments described herein are generally directed to improved apparatus and
10 methods for the delivery of laser energy, including without limitation, to a laser delivery
catheter.

BACKGROUND OF THE INVENTION

[0003] Arteries are the primary blood vessels that are responsible for providing blood and
oxygen to the heart muscle. Arterial disease occurs when arteries become narrowed or
15 blocked by a buildup of plaque (as some examples, atherosclerotic plaque or other deposits).
When the blockage is severe, the flow of blood and oxygen to the heart muscle is reduced,
causing chest pain. Arterial blockage by clots formed in a human body may be relieved in a
number of traditional ways. Drug therapy, including nitrates, beta-blockers, and peripheral
vasodilator drugs to dilate the arteries or thrombolytic drugs to dissolve the clot, can be
20 effective. If drug treatment fails, angioplasty may be used to reform or remove the
atherosclerotic plaque or other deposits in the artery.

[0004] Traditional balloon angioplasty is sometimes used to address the blockage by
inserting a narrow, flexible tube having a balloon into an artery in the arm or leg. The
blocked area in the artery can be stretched apart by passing the balloon to the desired
25 treatment site and gently inflating it a certain degree. In the event drug therapy is ineffective
or angioplasty is ineffective or too risky (often introduction of a balloon in an occluded artery
can cause portions of the atherosclerotic material to become dislodged which may cause a
total blockage at a point downstream of the subject occlusion thereby requiring emergency
procedures), the procedure known as excimer laser angioplasty may be indicated.

30 [0005] Excimer laser angioplasty procedure is similar in some respects to conventional
coronary balloon angioplasty. A narrow, flexible tube, the laser catheter, is inserted into an

artery in the arm or leg. The laser catheter contains one or more optical fibers, which can transmit laser energy. The laser catheter is then advanced inside the artery to the targeted obstruction at the desired treatment site. After the laser catheter has been positioned, the laser is energized to “remove” the obstruction.

5 [0006] In many procedures, the lesion is often engaged similar to conventional balloon angioplasty by crossing the blockage with a guidewire. The laser catheter's thin, flexible optical fibers facilitate the desired positioning and alignment of the catheter. Using the excimer laser, the clinician performs a controlled blockage removal by sending bursts of ultraviolet light through the catheter and against the blockage, a process called “ablation.”
10 The catheter is then slowly advanced through the blockage reopening the artery. If there are multiple blockages, the catheter is advanced to the next blockage site and the above step is repeated. When the indicated blockages appear to be cleared, the catheter is withdrawn.

[0007] However, due to the configuration of the optical fibers in most prior art laser catheters, the clinician is able to ablate only material that is typically directly in front of the
15 distal end of the catheter. Thus, the debulked tissue area is limited to an area approximately the size of the optical fiber area at the distal end of the catheter. Typically, follow-up balloon angioplasty is recommended.

[0008] Thus, it would be desirable to provide an apparatus and methods that could bias the distal end of the laser catheter in a desired direction to enable the clinician to ablate an area
20 larger than the area of the distal end of the catheter. Furthermore, because plaque may be eccentric in a blood vessel and require directional control to adequately ablate the target area, it would be advantageous to provide an apparatus that is sufficiently flexible to travel and rotate around the target area so that the clinician may control the area to be ablated.

BRIEF SUMMARY OF THE INVENTION

25 [0009] A catheter comprising a catheter body, a light guide, a distal tip, a retaining wire and a balloon is provided according to one embodiment. The catheter body, for example may include a central axis, a first proximal end and a first distal end. The catheter body may also include a lumen disposed between the first proximal end and the first distal end, the lumen having an opening at the first distal end. The light guide may include a second proximal end
30 and a second distal end. In some embodiments, the light guide may also include at least one optical fiber and may at least partially be disposed within the lumen and movable therein. The distal tip may be positioned at the periphery of the catheter body and extend from the

first distal end of the catheter body. The distal tip may also include a guidewire lumen that includes a guidewire port at the distal end of the distal tip. The retaining wire may be coupled with the distal tip and slidably coupled with the light guide. The balloon, for example, may be positioned between the opening at the first distal end of the catheter body
5 and the distal tip.

[0010] In some embodiments, the balloon may be configured to bias the light guide away from the central axis from the catheter body when the balloon is inflated. In some embodiments, the catheter may include a guidewire lumen. In some embodiments, at least a portion of the guidewire lumen may be located within the distal tip and/or a portion may be
10 located within the catheter body. In some embodiments, the guidewire lumen may be parallel with the lumen within the catheter body. In some embodiments, the catheter body may include a proximal guidewire port and/or a distal guidewire port. In some embodiments, the catheter may also include a balloon and/or a balloon lumen (or tube) coupled with the balloon. In some embodiments, the distal tip and/or the light guide may include a radiopaque
15 marker

[0011] A catheter having a first proximal end and a first distal end is provided according to another embodiment. The catheter may include a light guide lumen having a second distal end and a second proximal end, the second proximal end being substantially contiguous with the first proximal end, the second distal end having an opening. A distal tip may also be
20 included having a third proximal end and a third distal end, the third proximal end being substantially contiguous with the second distal end. The catheter may include a balloon lumen having a fourth distal end and fourth proximal end, the fourth proximal end being substantially contiguous with the second distal end. A balloon may be coupled with the balloon lumen at the fourth distal end. A guidewire lumen may be included that extends
25 through the distal tip.

[0012] In accordance with some embodiments, without limitation, the invention comprises a catheter having a catheter body including a central axis between a first proximal end and a first distal end. The housing has a lumen disposed between the first proximal end and the first distal end in communication with a cavity disposed proximate the first distal end. A
30 laser delivery member is movable and at least partially disposed within the lumen having a second proximal end and a second distal end. A ramp is disposed at an angle to the central axis and proximate the first distal end of the catheter body within the cavity. The ramp is in

communication with the lumen and is adapted to move the second distal end of the laser delivery member outwardly from the central axis of the elongated member. A guidewire is in mechanical communication with both the laser delivery member and the catheter body. The guidewire is adapted to bias the second distal end of the laser delivery member generally inwardly toward the central axis of the housing. In some embodiments, without limitation, the ramp is used to determine the offset of the central axis of the tip of the laser delivery member from the central axis of the housing, while keeping the axes substantially parallel, by adjusting the extent to which the laser delivery member travels on the ramp, and the disposition of the laser delivery member on the guidewire maintains the offset tip substantially parallel to the central axis of the housing. Methods of using same are also disclosed.

BRIEF DESCRIPTION OF THE DRAWINGS

[0013] The features and inventive aspects of the present invention will become more apparent upon reading the following detailed description, claims, and drawings, of which the following is a brief description:

[0014] FIG. 1 is perspective elevated view of a catheter according to one embodiment;

[0015] FIG. 2 is an exploded perspective view of a cavity of FIG. 1;

[0016] FIG. 3 is an exploded perspective view of FIG. 1 showing one embodiment of a ramp;

[0017] FIG. 4 is an exploded perspective view of FIG. 1 showing a ramp, a laser delivery member, and a guidewire;

[0018] FIG. 5 is a perspective elevated view of a first embodiment of a support structure;

[0019] FIG. 6 is a top plan view of FIG. 5;

[0020] FIG. 7 is a side plan view of FIG. 5;

[0021] FIG. 8 is a top plan view of a second embodiment of a support structure;

[0022] FIG. 9 is a side plan view of FIG. 8;

[0023] FIG. 10 is a perspective elevated view of a third embodiment of a support structure;

[0024] FIG. 11 is a top plan view of FIG. 10;

[0025] FIG. 12 is a perspective elevated view of a fourth embodiment of a support structure;

[0026] FIG. 13 is a perspective elevated view of a fifth embodiment of a support structure;

[0027] FIG. 14 is a perspective elevated view of a sixth embodiment of a support structure;

5 [0028] FIG. 15 is a top plan view of a seventh embodiment of a support structure; and

[0029] FIG. 16 is a perspective elevated view of FIG. 15.

[0030] FIG. 17 is a side view of a balloon biasing catheter according to one embodiment.

[0031] FIG. 18A shows a side view of the distal end of a deflated balloon biasing catheter according to one embodiment.

10 [0032] FIG. 18B shows a side view of the distal end of an inflated balloon biasing catheter according to one embodiment.

[0033] FIG. 18C shows a side view of the distal end of a deflated balloon biasing catheter with a proximal guidewire port within the catheter body according to one embodiment.

15 [0034] FIG. 18D shows a side view of the distal end of a deflated balloon biasing catheter with a proximal guidewire port proximal with the distal tip according to one embodiment.

[0035] FIG. 19 shows an end view of the distal tip of a balloon biasing catheter according to one embodiment.

[0036] FIG. 20 is a cutaway view of the distal tip of a balloon biasing catheter according to one embodiment.

20 [0037] FIG. 21 is a cutaway view of balloon biasing catheter showing a light guide, balloon lumen and guidewire lumen according to one embodiment.

[0038] FIGS. 22A, 22B, and 22C show a cutaway view of a balloon biasing catheter in use within a vessel according to one embodiment.

25 [0039] FIG. 23 is a flowchart describe one embodiment for using a balloon biasing catheter.

[0040] FIG. 24 is another flowchart describe one embodiment for using a balloon biasing catheter.

[0041] FIG. 25 shows a cutaway view of the distal tip of a balloon biasing catheter according to one embodiment.

DETAILED DESCRIPTION OF THE INVENTION

5 [0042] Referring now to the drawings, illustrative embodiments are shown in detail. Although the drawings represent some embodiments, the drawings are not necessarily to scale and certain features may be exaggerated to better illustrate and explain an innovative aspect of an embodiment. Further, the embodiments described herein are not intended to be exhaustive or otherwise limit or restrict the embodiments of the invention to the precise form
10 and configuration shown in the drawings and disclosed in the following detailed description.

[0043] Referring now to FIGS. 1 - 4, a catheter 10 is shown having an elongated housing 12. The elongated housing 12 includes a central axis between a first proximal end 14 and a first distal end 16. A cavity 18 is located proximate to the first distal end 16 of elongated housing 12 having a ramp 20 at an angle to the central axis of the housing 12. The angle of
15 the ramp 20 may but need not be the same over the length of the ramp. In some preferred embodiments, without limiting the scope of the invention, the housing includes a tapering end 30 and a guidewire aperture 32 capable of accepting the guidewire 28. A laser delivery member 22 comprising one or more optical fibers capable of transmitting light energy is disposed within a lumen 26 of the housing 12 having a second proximal end (not shown) and
20 a second distal end 24 movable therein. In some embodiments, without limitation, the laser delivery member 22 may be in mechanical communication with a guidewire 28 as further discussed below.

[0044] The guidewire 28 is threaded through a needle (not shown) into the artery and the needle is removed. The guidewire is advanced to or near the treatment site and may be
25 inserted at its distal end into or across the lesion to be treated, as desired. The guidewire 28 serves as a tracking guide for the housing 12 and laser delivery member 22 to run on. Guidewires for such uses are known in the art and may comprise those with diameters between about 0.010 and 0.06 inches, with 0.014 and 0.018 inches diameter being typical sizes for artery applications. The guidewires may have bendable tips of coiled wire or plastic
30 and a more rigid shaft of tapered ground stainless steel or other suitable material for push and torque transmission. The housing 12 and laser delivery member 22 are introduced coaxially,

either sequentially or simultaneously, onto the guidewire 28 and advanced to a target area as further discussed below.

5 [0045] In some embodiments, without limitation, the housing 12 is introduced onto the guidewire 28 that has been inserted into the patient, and the housing is advanced to or near the treatment site such that portions of the guidewire 28 are disposed at least initially within the guidewire aperture 32, tapering end 30, and lumen 26 of the housing. The laser delivery member 22 is then introduced onto the guidewire 28 so disposed within the catheter 10. The laser delivery member 22 is then advanced along the guidewire 28 such that the distal end 24 of the laser delivery member 22 becomes supported by the ramp 20 and oriented within the cavity 18 at any angle between 1 degree and 90 degrees in relation to the central axis of the housing 12, as desired by the user. Laser energy is then applied to the treatment site according to methods and protocols known to those of ordinary skill in the art. In some embodiments, without limiting the scope of the invention, in conjunction with the application of laser energy, the position of the laser delivery member 22 may optionally be varied by the user by moving the member 22 proximally or distally in order to adjust the angle of disposition of its distal end 24. Optionally, the offset of the central axis of the tip of the laser delivery member 22 from the central axis of the housing 12 may be varied by adjusting the distance that the delivery member 22 travels on the ramp 20 while keeping the central axis of the tip substantially parallel to the central axis of the housing 12. In addition, the catheter 10 containing the laser delivery member 22 may optionally be rotated along its central axis during the laser treatment and thereby apply laser energy to areas of the treatment site within the arc of the rotation. Optionally, the guidewire 28 may be withdrawn before application of laser energy and after the laser delivery member 22 has been introduced via the guidewire 28 into the lumen 26 of the housing 12.

25 [0046] The elongated housing 12 is an elongated structure having a lumen or lumen 26 large enough to accommodate the laser delivery member 22 and guidewire 28. The lumen 26 extends the entire length of the housing 12 from the first proximal end 14 to the first distal end 16. Optionally, in some embodiments, the lumen 26 may extend only to the ramp 20. Various control mechanisms including electrical, optical, and mechanical control mechanisms may be employed with the housing 12 permitting the catheter to be specifically directed to a target area (not shown) within the blood vessel. One embodiment of the housing includes a tapering end 30 and a guidewire aperture 32 capable of accepting the guidewire 28. The housing 12 may be made from any rigid, semi-flexible, or flexible material including a

combination thereof made from a material including metal, plastic, rubber, and the like.

Round or flat metal ribbon wire may be embedded within the material, inserted through the cavity 18, or disposed at the first distal end 16 to add stability to the housing 12 at the first distal end 16. The length of the housing 12 may be varied as desired. The housing 12 may
5 be one piece or have a plurality of sections including a support structure section at the first distal end 16 as discussed further below. The distal end 16 of the housing 12 may include a non-traumatic polymer tip separate or integrated into the housing 12. This allows the forces seen in bending to be dissipated throughout the structure, reducing stress risers that could cause failure. The housing 12 may also include at least one wire disposed within the lumen
10 26 to add robustness to the housing 12. The lumen 26 is in communication with cavity 18 and wire aperture 32. The lumen 26 is open to the exterior of the housing 12 through the cavity 18.

[0047] The ramp 20 is disposed within cavity 18 and is configured to project the laser delivery member 22 outwardly at various determinable angles. Optionally, the ramp 20 is
15 used to determine the offset of the central axis of the tip of the laser delivery member 22 from the central axis of the housing 20, while keeping the axes substantially parallel, by adjusting the extent to which the laser delivery member 22 travels on the ramp 20. In some embodiments without limitation, the disposition of the laser delivery member 22 on the guidewire 28 maintains the offset tip substantially parallel to the central axis of the housing
20 12. In some embodiments, without limitation, the angle of lateral deviation of the ramp 20 from central axis of the housing 12 will vary in range as desired from one (1) degree to ninety (90) degrees, more usually in the range from thirty (30) degrees to sixty-five (65) degrees. By employing ramp 20 having different exit angles from the associated lumen 26, different angles and/or offsets may be selected for treating a target area after the catheter 10 has been
25 located within a patient. In some embodiments, without limitation, the ramp 20 may be adjustable, as one example only, by inflation of a balloon, and/or the ramp 20 may be slidable to allow varying degrees of offset.

[0048] The ramp 20 may be a built-up feature within the lumen 26 of the housing 12 and may be located anywhere along the longitudinal length of the housing 12, but preferably at or
30 within about 3 cm from the first distal end 16 of the housing 12. The ramp 20 may be formed or fused to the internal wall of the housing 12 and made from metal, plastic, rubber, and the like. In one embodiment, the ramp length (RL) is generally 1 cm. However, the ramp length (RL) may also be varied.

[0049] The first distal end 16 of the housing 12 may be formed from plastic, metal, or any combination thereof. When metal is used, materials must be selected to provide appropriate flexibility without producing failure since the cavity 18 tends to reduce the structural integrity of some portions of the housing 12. Thus, in some embodiments, the first distal end 16
5 comprises a shape memory alloy, as one example only, nickel-titanium alloy. In other embodiments, without limitation, the first distal end 16 may comprise a stent-like structure proximal, distal, within, or a combination of such proximate the cavity 18. The stent-like structure may be made from at least one of stainless steel, cobalt-chromium, nickel titanium, and the like.

10 [0050] An alternative embodiment of the housing 12 comprises having at least one section at the first distal end 16. A first embodiment of a support structure is support member 34 as shown in FIGS. 5 - 7. The support member 34 may be used to support the first distal end 16 while providing flexibility without producing failure. The first distal end 16 of the housing 12 may otherwise experience limited torsional and bending strength of the area around the
15 cavity 18 specifically traversing bends having a radius of about 0.75 inches. The support member 34 assists in withstanding the torsional and bending forces when traversing bends of about 0.75 inches, while maintaining aspects of both integrity and functionality. In some embodiments, without limitation, support member 34 reinforces the area around the cavity 18 at the first distal end 16 with struts 36 forming a stent-like pattern 38. Support member 34 is
20 formed from metal, plastic, or combinations thereof, and is at least partially axially disposed around the wall of the first distal end 16 of the housing 12. The housing 12 may be one longitudinal piece or have a plurality of sections including the support structure as described above disposed at the first distal end 16 of the housing 12. Other embodiments of the support structure include a marker band proximate the first distal end 16 of the housing 12 and
25 radiopaque markers at various intervals along the ramp 20 to demarcate acceptable ramp 20 positions for the catheter 10. As one example only, a user may place a catheter at a first mark on the ramp to increase the offset for ablation to 1mm. A second mark might equal a 1.5 mm offset. This way the support structure may be used progressively, as one example only, as a progressive atherectomy tool. Additional embodiments having generally similar benefits
30 may also be used, as further discussed below.

[0051] Referring to FIGS. 8 and 9, a second embodiment of a support structure is shown as second support member 40 having a spring-like geometry 42. The support member 40 may be used to support the first distal end 16 while providing flexibility without producing failure.

The second support member 40 acts as a backbone for the first distal end 16 of the housing 12. The spring-like geometry 42 permits flexing without causing failure. The height H of the spring-like geometry 42 may be of any height but is preferably below the centerline of the second support member 40. The ramp 20 may be molded over the spring like geometry 42 including having a top coat (not shown).

[0052] Referring to FIGS. 10 and 11, a third embodiment of a support structure is shown as a third support member 44. The support member 44 may be used to support the first distal end 16 while providing flexibility without producing failure. The third support member 44 provides variable stiffness along the length of the member 44. Member 44 is the most rigid at rib 46 and most flexible at rib 48. This flexibility is accomplished by having the ribs increase in width W and distance D in addition to decreasing the side of a beam 50 as shown in FIG. 11. Beam 50 tapers from a first wide beam width BW1 to a narrower beam width BW2. A tip 52 having a tip length TL disposed at the distal end support member 44 functions to provide support for the first distal end 16 of the housing 12 while allowing additional flexibility. The ramp 20 may be molded over the spring-like geometry 42 including having a top coat (not shown). The support member length L may be varied depending on user requirements including varying the tip length TL.

[0053] FIG. 12 shows a fourth embodiment of a support structure as fourth support member 54 disposed at the first distal end 16 of the housing 12. The support member 54 may be used to support the first distal end 16 while providing flexibility without producing failure. Support member 54 includes a rigid body 56 and a variably rigid base 58 extending from the body 56. Body 56 includes an aperture 57 in communication with lumen 26. The base 58 may be elastomeric having the greatest flexibility at distal end 60. The ramp 20 may be molded over the base 58 including having a top coat (not shown). The support member base length BL may be varied according to user requirements.

[0054] FIG. 13 shows a fifth embodiment of a support structure as fifth support member 62. The support member 62 includes a rigid body 64 having a flexible tapered nose portion 66. At least the nose portion 66 may be comprised of elastomeric material, as one example only, Rebax 55D available from Arkema. The body 64 is configured to communicate with the first distal end 16 of the housing 12. An aperture 68 is disposed within body 64 in communication with lumen 26 of the housing 12 and is configured to accommodate both the laser delivery member 22 and guidewire 28. Aperture 68 is also in communication with the

nose widow 69. The nose window 69 of the nose portion 66 includes a nose ramp 70 configured to project the laser delivery member 22 outwardly at various predetermined angles. Optionally, the ramp 20 is used to determine the offset of the central axis of the tip of the laser delivery member 22 from the central axis of the housing 20, while keeping the axes substantially parallel, by adjusting the extent to which the laser delivery member 22 travels on the ramp 20. In some embodiments without limitation, the disposition of the laser delivery member 22 on the guidewire 28 maintains the offset tip substantially parallel to the central axis of the housing 12. Usually, the angle of lateral deviation of the ramp 20 from the housing 12 will vary in range as desired from one (1) degree to ninety (90) degrees, more usually in the range from thirty (30) degrees to sixty-five (65) degrees. The nose portion also includes a nose lumen 72 and a nose guidewire aperture 74. The guidewire 28 disposed within and in mechanical communication the laser delivery member 22 extends outwardly from the second distal end 24 of the laser delivery member 22 and is guided through the nose lumen 72 and extending out the guidewire aperture 74. Both the nose lumen 72 and guidewire aperture 74 provide securement for the guidewire 28 so that the guidewire 28 may properly bias the second distal end 24 of the laser delivery member 22 generally inwardly toward the central axis of the body 64.

[0055] FIG. 14 shows a sixth embodiment of a support structure as sixth support member 80. The support member 80 may be used to support the first distal end 16 while providing flexibility without producing failure. Support member 80 includes a rigid body 82 and at least two variably rigid legs 84 extending from the body 82. Body 82 includes an aperture 86 in communication with the lumen 26. The body 82 may be elastomeric having the greatest flexibility at distal end 88. The legs 84 may be of any shape extending from the body 82. The ramp 20 may be molded over the legs 84 including having a top coat (not shown). The support member leg length LL may be varied depending on user requirements.

[0056] FIGS. 15 and 16 show a seventh embodiment of a support structure as seventh support member 90. The support member 90 may be used to support the first distal end 16 while providing flexibility without producing failure. The first distal end 16 of the housing 12 may otherwise experience limited torsional and bending strength of the area around the cavity 18 specifically traversing bends having a radius of about 0.75 inches. The support member 90 assists in withstanding the torsional and bending forces when traversing bends of about 0.75 inches while maintaining both integrity and functionality. Support member 90 reinforces the area around the cavity 18 at the first distal end 16 with a braid 92 forming a

stent-like pattern 94. Support member 90 is formed from metal or plastic and is at least partially axially disposed around the wall of the first distal end 16 of the housing 12. The housing 12 may be one longitudinal piece or have a plurality of sections including the support structure as described above disposed at the first distal end 16 of the housing 12. Support member 90 includes a rigid body 92 and a variably rigid base 94 forming the stent-like pattern 94 extending from the body 92. Body 92 includes an aperture 96 in communication with lumen 26. The base 94 may be elastomeric having the greatest flexibility at distal end 98. A tip 100 having a tip length TL disposed at the distal end support member 90 functions to provide support for the first distal end 16 of the housing 12 while allowing additional flexibility. The ramp 20 may be molded over the base 94 including having a top coat (not shown). The support member stent-like length SL may be varied depending on user requirements.

[0057] In operation, once the guidewire 28 is in place, or as it is being positioned, the housing 12 is inserted. This housing 12 has a central lumen 26, which may include the laser delivery member 22 and guidewire 28. The housing 12 and the laser delivery member 22 are advanced through the guidewire into the desired target area. Therefore, the guidewire 28 is in mechanical communication with both the laser delivery member 22 and the elongated housing 12. However, the housing 12 may be advanced prior to inserting the laser delivery member 22. As the laser delivery member 22 approaches the ramp 20, it is biased in an outwardly direction through the cavity 18. The further the laser delivery member 22 is advanced, the more it projects outwardly from the cavity 18 at the first distal end 16 of the housing 12. In some embodiments, without limitation, the guidewire 28 disposed within the laser delivery member 22 biases the second distal end 24 of the laser delivery member 22 inwardly providing a travel path and forcing the second distal end 24 to face forward along the guidewire 28 and generally parallel to the centerline of the housing 12. Otherwise, the second distal end 24 of the laser delivery member 22 would continue along the ramp 20 further projecting away from the centerline of the housing 12 and would not be “attacking” the target area in front of the catheter 10 as desired.

[0058] FIG. 17 is a side view of a balloon biasing catheter according to one embodiment. A balloon biasing catheter may include a catheter body 1705 (or elongated housing) with a light guide 1710 disposed within a lumen of catheter body 1705 and extending from an aperture within catheter body 1705. For example, light guide 1710 may include a plurality of fiber optics. As another example, the light guide may be a liquid light guide and/or a

combination of a liquid light guide and a fiber optic light guide. In some embodiments, the light guide is free to slide within the lumen of the catheter body. In some embodiments, the light guide lumen may slide relative to the catheter body. In other embodiments, the light guide may be fixed within the lumen of the catheter body. Light guide 1710 may be located
5 within catheter body 1705 and may extend from the proximal end of the catheter body to the distal end of the catheter body. At the proximal end of the catheter body, light guide 1710 may be coupled with a laser coupler. The light guide lumen may include an aperture at or near the distal end of catheter body 1705 from which light guide 1710 may extend. In some
10 embodiments, light guide 1710 may extend 1-10 mm from the aperture. In some
embodiments, light guide 1710 may also include a radiopaque marker band 1712 near the distal end.

[0059] A balloon biasing catheter may also include a guidewire lumen. The guidewire lumen may be configured to allow a guidewire to pass and/or slide therethrough. In some embodiments, the guidewire lumen may extend, for example, from distal guidewire port 1720
15 through a portion of catheter body 1705. In some embodiments, the guidewire lumen may extend to or near the proximal end of catheter body 1705. In other embodiments, guidewire lumen may extend from the distal end to a position proximal with the light guide aperture and/or proximal with balloon 1810. The guidewire lumen may be configured to accept a guidewire and allow the guidewire to slide within the guidewire lumen 1812. Proximal
20 guidewire port 1720 may be located any where along catheter body 1705.

[0060] FIG. 18A shows a side view of the distal end of a balloon biasing catheter with a deflated (or partially deflated) balloon. Distal tip 1733 extends beyond the catheter body. In some embodiments, distal tip 1733 may be integral with catheter body 1705; for example, distal tip 1733 may be manufactured as part of catheter body 1705. In some embodiments,
25 distal tip 1733 extends beyond the aperture of the light guide lumen. In some embodiments, distal tip 1733 may be contiguous and/or coterminal with a peripheral portion of the catheter body. Guidewire lumen 1812 extends through distal tip 1733 and terminates at distal guidewire port 1720. Accordingly, in some embodiments, a balloon biasing catheter may slide over a previously placed guidewire by introducing the proximal end of the guidewire
30 through distal guidewire port 1720, into guidewire lumen 1812, and then sliding the balloon biasing catheter over the guidewire within guidewire lumen 1812. The proximal end of the guidewire may then exit the balloon biasing catheter through proximal guidewire port 1725. Distal tip 1733 may also include a radiopaque marker 1805.

[0061] Distal tip 1733 may also include balloon 1810. Balloon 1810 may be located between distal tip 1733 and the distal end of light guide 1710. In some embodiments, distal tip 1733 may include a shelf-like structure upon which balloon 1810 may be positioned. Balloon 1810 may be coupled with a balloon lumen (or tube) 1813. Balloon lumen 1813 may extend to balloon port 1730. Balloon 1810 may be inflated and/or deflated by pressurizing balloon lumen 1813 with liquid using balloon port 1730. By inflating balloon 1810, light guide 1710 may be biased away from the central axis of catheter body 1705 as shown in FIG. 18B. It should be noted, that in some embodiments light guide 1710 remains relatively parallel with the central axis of catheter body 1705 and/or distal tip 1733 when balloon 1810 is inflated. As will be discussed, retaining wire 1715 aids in keeping light guide 1710 relatively parallel with catheter body 1705. Balloon 1810, for example, may deflect light guide 1710 1.0 mm. In other embodiments, light guide 1710 may be biased 0.5 mm, 1.5 mm, 2.0 mm, 2.5 mm, 3.0 mm etc. away from the central axis of catheter body 1705. By biasing the light guide, the balloon biasing catheter may ablate a larger diameter area than if the light guide is not biased.

[0062] Balloon lumen may couple with a luer fitting at balloon port 1730. Balloon port 1730 may be proximate with catheter body 1705 as shown. In some embodiments, balloon lumen may bifurcate with the catheter body and may extend a distance away from the catheter body. Balloon lumen 1813 may include a small diameter lumen. For example, the inner diameter of balloon lumen may be approximately 0.001 inches. In some embodiments, the inner diameter of balloon lumen 1813 may be between 0.0005 and 0.01 inches. The outside diameter of balloon lumen 1813, for example, may be 0.016 inches. In some embodiments, the outside diameter of balloon lumen 1813 may be 0.05 to 0.005 inches. At balloon port 1730 or luer, balloon lumen 1813 may be coupled with a syringe or an inflator. Balloon 1810 may be inflated by injecting fluid through balloon lumen 1813 using either a syringe or an inflator. In some embodiments, the balloon may be inflated using a contrast agent fluid or saline solution. Balloon lumen 1813 may include any type of plastic tubing known in the art. For example, balloon lumen 1813 may comprise nylon, Teflon, polyethylene, etc.

[0063] Balloon 1810 may have a diameter of about 1 mm to 3 mm when inflated, according to one embodiment. In some embodiments, balloon may have an inflated diameter up to about 5 mm and as little as 0.5 mm. In some embodiments, balloon 1810 may comprise a portion of tubing with a sealed distal end. In some embodiments, a portion of tubing may

form balloon 1810 and have thinner walls and/or a larger diameter such that the balloon portion of the tubing inflates under pressure. Balloon 1810, for example, may comprise any type of plastic, for example, balloon 1810 may comprise nylon, Teflon, polyethylene, etc. Balloon 1810, in some embodiments, may extend the entire length of distal tip 1733. For example, balloon 1810 may be 10 cm, 9 cm, 8 cm, 7 cm, 6 cm, 5 cm, 4 cm, 3 cm, 2 cm, or 1 cm in length.

[0064] Retaining wire 1715 may be detachably coupled with either or both distal tip 1733 and/or light guide 1710. For example, retaining wire 1715 may be connected with the distal tip using solder, clamps, glue, fused, etc. In some embodiments, retaining wire is soldered with radiopaque marker band 1712. In other embodiments, retaining wire 1715 may be coiled around the distal tip and glued or fused with distal tip 1733. In some embodiments, retaining wire 1715 may be sandwiched between distal tip 1733 and radiopaque marker band 1712. In some embodiments, retaining wire 1715 may extend through a portion of light guide 1710 as shown in FIG. 18A. For example, retaining wire 1715 may extend through light guide 1710 next to and/or with a plurality of optical fibers. Retaining wire 1715 may aid in retaining the position and/or bias of the light guide when balloon 1810 is deflated. Retaining wire 1715 may also aid in providing the proper bias when balloon 1810 is inflated. For example, retaining wire may be lengthened and/or include elasticity such that balloon biasing catheter may be more or less biased when balloon 1810 is inflated. In some embodiments, retaining wire provides resistance to light guide 710 when balloon 1810 is inflated, which may align light guide 1710 parallel with distal tip 1733 and/or catheter body 1705.

[0065] FIG. 18C shows a side view of the distal end of a balloon biasing catheter with a deflated (or partially deflated) balloon with proximal guidewire port 1822 disposed more toward the proximal end of the balloon biasing catheter than the distal end of light guide 1710 and balloon 1810. FIG. 18D shows proximal guidewire port 1822 disposed proximate with distal end of light guide 1710 and balloon 1810.

[0066] FIG. 19 is an end view of the balloon biasing catheter shown in FIG. 18A according to one embodiment. A catheter sheath 1705 (or elongated housing or catheter body) is shown containing a plurality of optical fibers 1905. In some embodiments, catheter sheath 1705 may have a diameter of approximately 2.0 mm. Each of the fibers, for example, may be less than about 0.1 mm. As another example, the fibers may be less than about 0.05 mm. The fiber optics may be contained within lumen 1911. For example, lumen 1911 may be about 1.0 mm by about 2.0 mm. Guidewire lumen 1910 is located beneath lumen 1911. Guidewire

lumen 1910, for example, may have an inside diameter of approximately 0.024 inches and inside diameter 0.018 inches. In other embodiments, guidewire lumen 1812 may have an outside diameter less than about 0.025 inches and/or an inside diameter less than about 0.02 inches.

5 [0067] Balloon 1810 may be positioned between guidewire lumen 1812 and optical fiber lumen 1911. Retaining wire 1715 is also shown. In the embodiment shown in FIG. 19, retaining wire 1715 is a flat wire. In other embodiments, retaining wire 1715 may be any type of wire, such as a round, rectangular, square and/or oval shaped wire. In FIG. 20 optical fiber lumen 1925 may be a separate round and/or oval shaped lumen and may be found
10 within a tube. Moreover, other retaining device may be employed that retain a first bias of the that is generally parallel with the central axis of the catheter sheath when the balloon is deflated and permit a radial bias of the catheter tip when the balloon is inflated.

[0068] FIG. 20 is a cutaway view of the distal tip of a balloon biasing catheter according to one embodiment. This cutaway view is provided along line Y-Y in FIG. 18A. As shown in
15 this embodiment, retaining wire 1715 is disposed within optical fiber lumen 1925. In some embodiments, retaining wire 1715 extends, for example, about 1 cm into optical fiber lumen 1925. In some embodiments, retaining wire 1715 can run the distance of the catheter body toward the proximal end and be secured at a termination point.

[0069] FIG. 21 is a cutaway view of balloon biasing catheter showing a optical fiber lumen
20 1925, balloon lumen 1813 and guidewire lumen 1812 within catheter sheath according to one embodiment. Balloon lumen 1813 may be disposed within a tube or other hollow member. Guidewire lumen 1812 may also be disposed within a tube or other hollow member. This cutaway view is provided along line Z-Z in FIG. 18A and/or X-X in FIG 17.

[0070] FIG. 22A shows a cutaway of a balloon biasing catheter in use within vessel 2200
25 near target 2205. The balloon biasing catheter may be inserted into vessel 2200 by following guidewire 2220. Guidewire 2220 may run through the guidewire lumen as shown in the figure. Balloon 1810 is deflated in FIG. 22A. Light guide 1710 may be activated and a portion of target 2220 may be ablated. FIG. 22B shows target 2205 after ablation with balloon biasing catheter positioned as shown in FIG. 22. Target 2205 may not be completely
30 ablated leaving target portions 2210 and 2215. In some embodiments, a hole within target 2210 may result.

[0071] FIG. 22B shows light guide 1710 biased axially by inflating balloon 1810. When balloon 1810 is inflated, light guide 1710 may be in position to ablate at least some of target portion 2210. Moreover, balloon 1810 may be partially or fully inflated as needed to align light guide 1710 with target portion 2210. FIG. 22C shows a resulting example of ablation using the configuration in FIG. 22B. Target portion 2210 has been partially ablated. In some embodiments, target portion 2210 may be completely ablated. FIG. 22C also shows balloon biasing catheter rotated within vessel 2200 about 180° and positioned to ablate target portion 1715. In some embodiments, balloon 1810 may be deflated prior to rotation and reinflated after rotation. In some embodiments, balloon biasing catheter and/or guidewire 2220 may be advanced during any of the ablation steps. In some embodiments, balloon biasing catheter may be rotated 90° or any other angle in order to ablate other target portions and/or material near or adhering to a vessel wall.

[0072] FIG. 23 shows a flowchart of a process for using a balloon biasing catheter according to one embodiment. Various other processes may be used that add to or take away from the process shown in FIG. 23 and described below. The proximal end of a guidewire is inserted through the distal guidewire port at the distal tip of the balloon biasing catheter at block 2305. The balloon biasing catheter may then be inserted into a vessel at block 2310 and slid over the guidewire and positioned near a target at block 2315. At block 2320 the laser may be activated ablating a portion of the target area. The balloon biasing catheter may be advanced at block 2323. Once ablation is complete, the laser is deactivated at block 2325. If portions of the target are not completely ablated, for example, if material remains near the vessel walls, then the balloon may be inflated at block 2330. When the balloon is inflated the distal tip of the balloon biasing catheter may be radially biased yet substantially parallel with the balloon biasing catheter and positioned to ablate unablated portions of the target. The laser may again be activated at block 2335 and portions of the target ablated. At block 2338 the balloon biasing catheter may be advanced toward the target. At block 2340 the laser is deactivated after a period of time and the balloon deflated at block 2345. If the ablation area is satisfactory and no more ablation is required as decided at block 2350 the balloon biasing catheter is removed at block 2360. However, if more ablation is required, the balloon biasing catheter may be rotated axially within the vessel at block 2355 and the process returns to block 2330.

[0073] FIG. 23 shows a flowchart of a process for using a balloon biasing catheter according to one embodiment. This flow chart is substantially similar to the flowchart shown

in FIG. 23. In this embodiment, however, at blocks 2423 and 2438 the light guide is advanced relative to the balloon biasing catheter. In such embodiments, the catheter body remains substantially still as the light guide is advanced to ablate target material.

[0074] FIG. 25 shows a cutaway view of a balloon biasing catheter according to one
5 embodiment. For example, this cutaway view may be cut along lines X-X, or Z-Z in FIG.
18A. As shown, the guidewire lumen 1812 is shown exterior to and attached with catheter
body 1705. The guidewire lumen 1812 may be disposed as shown within a tube. Moreover,
guidewire lumen 1812 may be disposed anywhere within optical fiber lumen 1925. Balloon
10 lumen 1813 in this embodiment is disposed within optical fiber lumen 1925 along with a
plurality of optical fibers 1905. In other embodiments, balloon lumen may be disposed
external to the catheter body 1705 either with or without the guidewire lumen 1812.

[0075] The preceding description has been presented only to illustrate and describe
exemplary embodiments of the methods and systems of the present invention. It is not
intended to be exhaustive or to limit the invention to any precise form disclosed. It will be
15 understood by those skilled in the art that various changes may be made and equivalents may
be substituted for elements thereof without departing from the scope of the invention. In
addition, many modifications may be made to adapt a particular situation or material to the
teachings of the invention without departing from the essential scope. Therefore, it is
intended that the invention not be limited to the particular embodiment disclosed as the best
20 mode contemplated for carrying out this invention, but that the invention will include all
embodiments falling within the scope of the claims. The invention may be practiced
otherwise than is specifically explained and illustrated without departing from its spirit or
scope.

WHAT IS CLAIMED IS:

- 1 1. A catheter comprising:
2 a catheter body having a central axis, a proximal end and a distal end, the
3 catheter body having a lumen disposed between the proximal end and the distal end, the
4 lumen having an opening at the distal end;
5 a light guide having a proximal end and a distal end, the light guide being at
6 least partially disposed within the lumen and movable therein;
7 a tip distally extending from the distal end of the catheter body;
8 a retaining wire coupled with the tip and slidably coupled with the light guide;
9 and
10 a balloon positioned within the opening, wherein the balloon is inflatable to
11 adjust the position of the distal end of the light guide.
- 1 2. The catheter according to claim 1, wherein the light guide comprises at
2 least one optical fiber.
- 1 3. The catheter according to claim 1, wherein the light guide comprises a
2 liquid medium.
- 1 4. The catheter according to claim 1, wherein the balloon is configured to
2 bias the light guide away from the central axis from the catheter body when the balloon is
3 inflated.
- 1 5. The catheter according to claim 1, further comprising a guidewire
2 lumen.
- 1 6. The catheter according to claim 5, wherein at least a portion of the
2 guidewire lumen is disposed within the tip.
- 1 7. The catheter according to claim 5, wherein at least a portion of the
2 guidewire lumen is disposed within the catheter body.
- 1 8. The catheter according to claim 5, wherein the catheter body includes a
2 proximal guidewire port coupled with the guidewire lumen.

1 9. The catheter according to claim 8, wherein the proximal guidewire port
2 is disposed proximate with the tip.

1 10. The catheter according to claim 8, wherein the proximal guidewire port
2 is disposed proximal to the tip.

1 11. The catheter according to claim 5, wherein the guidewire lumen
2 includes a distal port at a distal end of the tip.

1 12. The catheter according to claim 1, further comprising a balloon lumen
2 coupled with the balloon and extending within the catheter body.

1 13. The catheter according to claim 1, wherein the tip includes a
2 radiopaque marker near the distal end of the tip.

1 14. The catheter according to claim 1, wherein light guide includes a
2 radiopaque marker near the second distal end of the light guide.

1 15. The catheter according to claim 1, wherein the retaining wire holds the
2 second distal end of the light guide substantially parallel with the tip.

1 16. A catheter comprising:
2 a catheter body having a proximal end, a distal end, and a central axis;
3 a light guide disposed within the catheter body, the light guide having a
4 proximal end contiguous with the proximal end of the catheter body, the light guide having a
5 central axis substantially parallel with the central axis of the catheter body, the light guide
6 extending from a light guide aperture within the catheter body;

7 a tip extending from the distal end of the catheter body proximate with the
8 light guide aperture;

9 a balloon disposed proximate with the tip and proximate with the light guide
10 aperture; and

11 a guidewire lumen extending through the tip and terminating at an aperture
12 proximate with the distal end of the tip.

1 17. The catheter according to claim 16, further comprising a retaining wire
2 coupled with the tip and slidably coupled with the light guide.

1 18. The catheter according to claim 17, wherein the retaining wire applies
2 a bias force on the light guide and retains the light guide substantially parallel with the tip.

1 19. The catheter according to claim 16, wherein the guidewire lumen
2 includes a proximal guidewire port disposed within the catheter body proximal relative to the
3 light guide aperture.

1 20. The catheter according to claim 16, wherein the guidewire lumen
2 includes a proximal guidewire port disposed within the catheter body proximate with the light
3 guide aperture.

1 21. The catheter according to claim 16, further comprising a balloon lumen
2 coupled with the balloon and extending at least through a portion of the catheter body.

1 22. The catheter according to claim 21, wherein the catheter includes a
2 balloon port coupled with the balloon lumen end and coupled with the catheter body.

1 23. The catheter according to claim 16, wherein the tip is disposed at the
2 periphery of the catheter.

1 24. The catheter according to claim 16, wherein the balloon is disposed
2 between the tip and the light guide aperture.

1 25. The catheter according to claim 16, wherein the guidewire lumen
2 extends through at least a portion of the catheter.

1 26. The catheter according to claim 16, wherein the balloon is configured
2 to bias the light guide away from the tip when inflated.

1 27. The catheter according to claim 16, wherein the balloon is configured
2 to bias the light guide approximately 1 mm away from the tip when inflated.

1 28. A catheter comprising:
2 a catheter body including a proximal end and a distal end;
3 a light guide disposed within the catheter body, including a distal end
4 extending from a light guide aperture near the distal end of the catheter body, the light guide
5 including a proximal end contiguous with the catheter body proximal end;

6 a tip coupled with and extending from the distal end of the catheter body;
7 a retaining wire coupled with the tip and the light guide;
8 a balloon disposed proximate to the light guide aperture and the tip;
9 a balloon lumen coupled with the balloon and extending through at least a
10 portion of the elongate housing;
11 a guidewire lumen disposed at least within the tip and including a guidewire
12 aperture at the distal end of the tip; and
13 a laser coupled with the proximal end of the light guide.

1 29. The catheter according to claim 28, wherein the retaining wire is
2 slidably coupled with the light guide.

1 30. The catheter according to claim 28, wherein the balloon is configured
2 to bias the light guide away from the tip when inflated.

1 31. The catheter according to claim 28, wherein the retaining wire retains
2 the tip of the light guide substantially parallel with the tip.

1 32. A method for using an balloon biasing catheter comprising:
2 inserting the balloon biasing catheter into a vessel, wherein the balloon biasing
3 catheter includes a catheter body, a light guide disposed within the catheter body and coupled
4 with a laser, a tip, a retaining wire coupled with the tip and the light guide and a balloon
5 positioned to move the tip of the light guide when inflated;
6 positioning the distal end of the balloon biasing catheter near a target within
7 the vessel;
8 radially offsetting the distal tip of the light guide by inflating the balloon,
9 wherein the distal tip of the catheter remains substantially parallel with the catheter body;
10 activating the laser.

1 33. The method according to claim 32, further comprising threading a
2 guidewire through the guidewire lumen.

1 34. A catheter comprising:
2 a catheter body having a proximal end, a distal end, and a central axis;
3 a light guide disposed within the catheter body, the light guide having a
4 proximal end contiguous with the proximal end of the catheter body, the light guide having a

5 central axis substantially parallel with the central axis of the catheter body, the light guide
6 extending from a light guide aperture within the catheter body;
7 a tip extending from the distal end of the catheter body proximate with the
8 light guide aperture; and
9 a guidewire lumen extending through the tip and terminating at an aperture
10 proximate with the distal end of the tip.

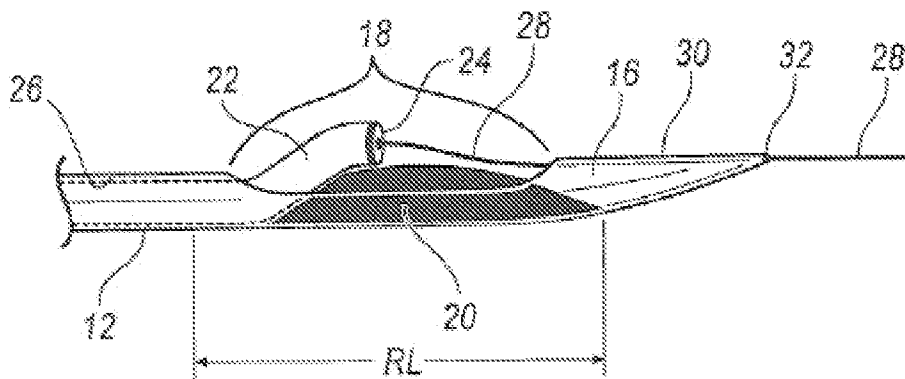
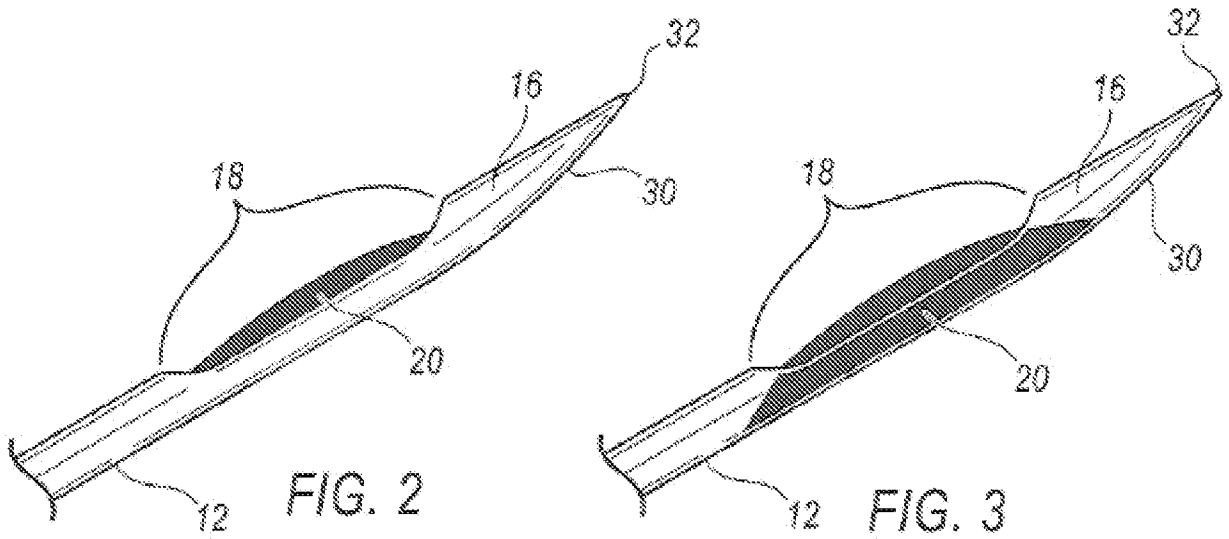
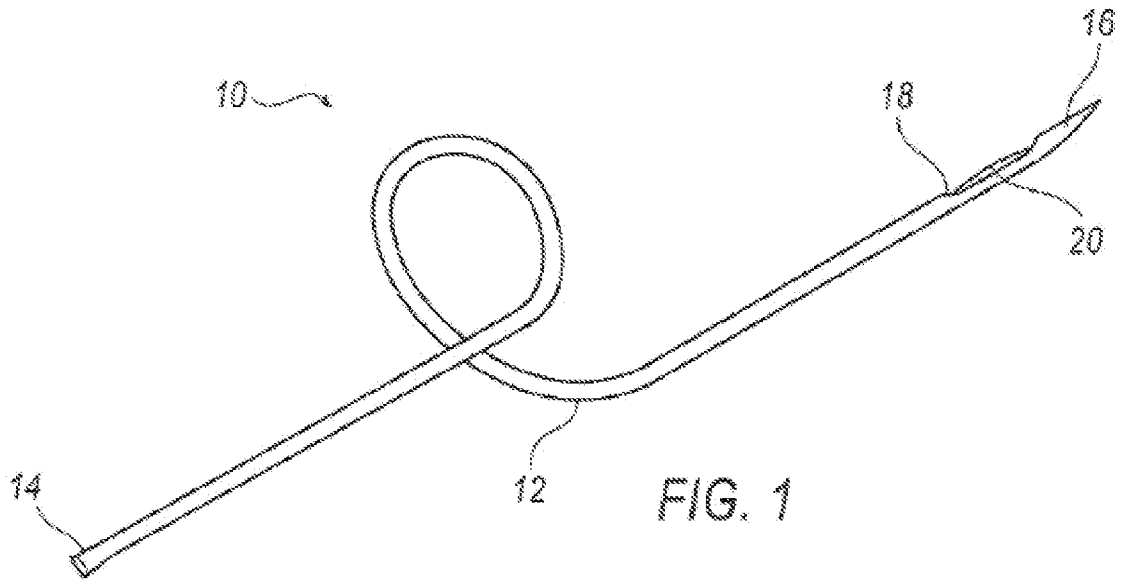

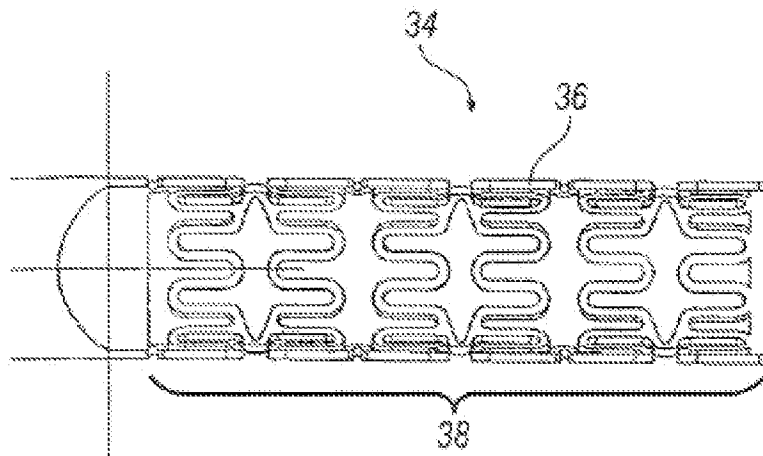
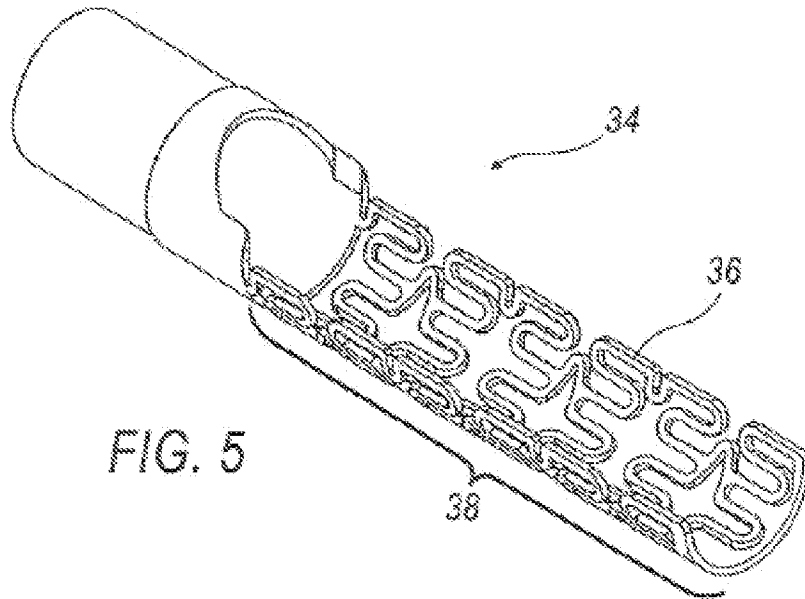

FIG. 6

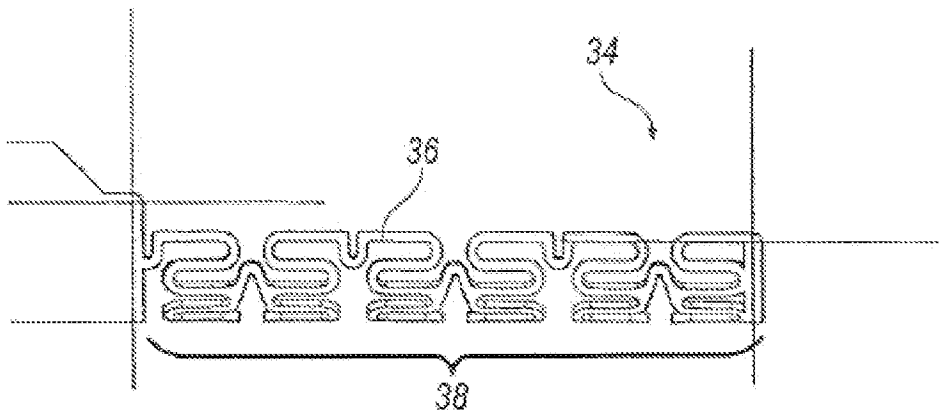

FIG. 7

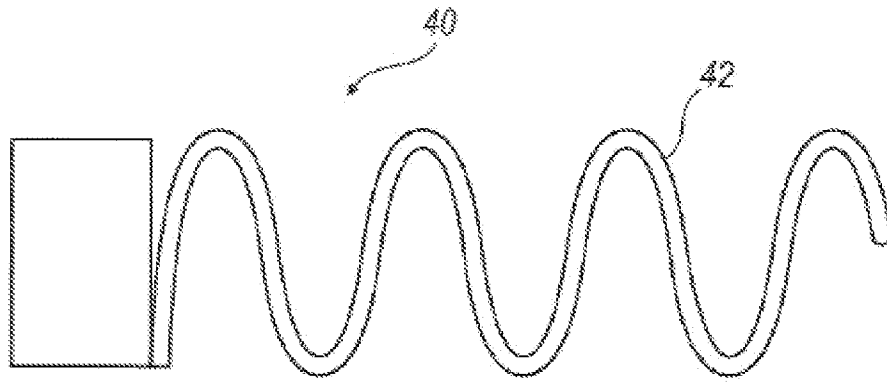

FIG. 8

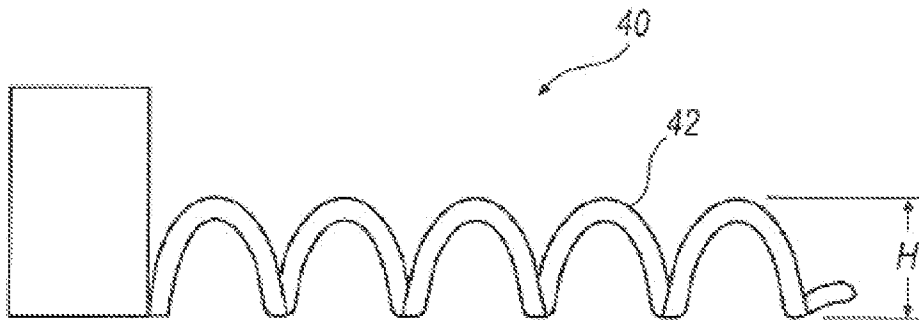
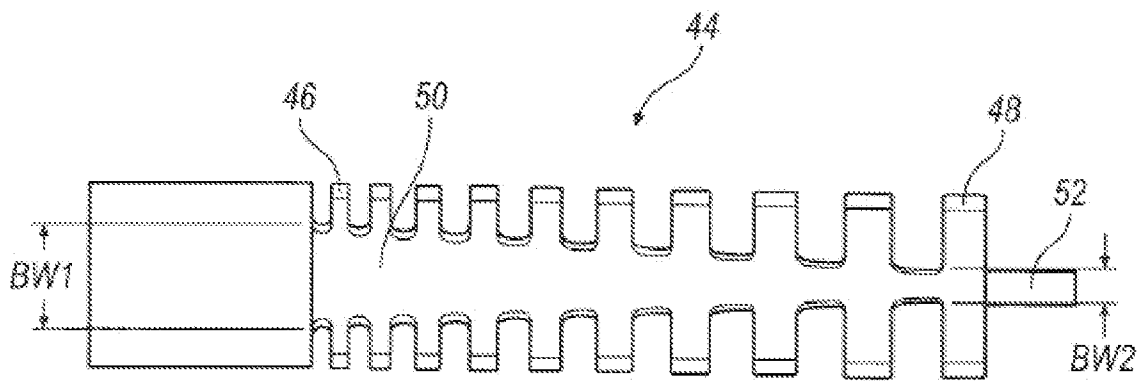
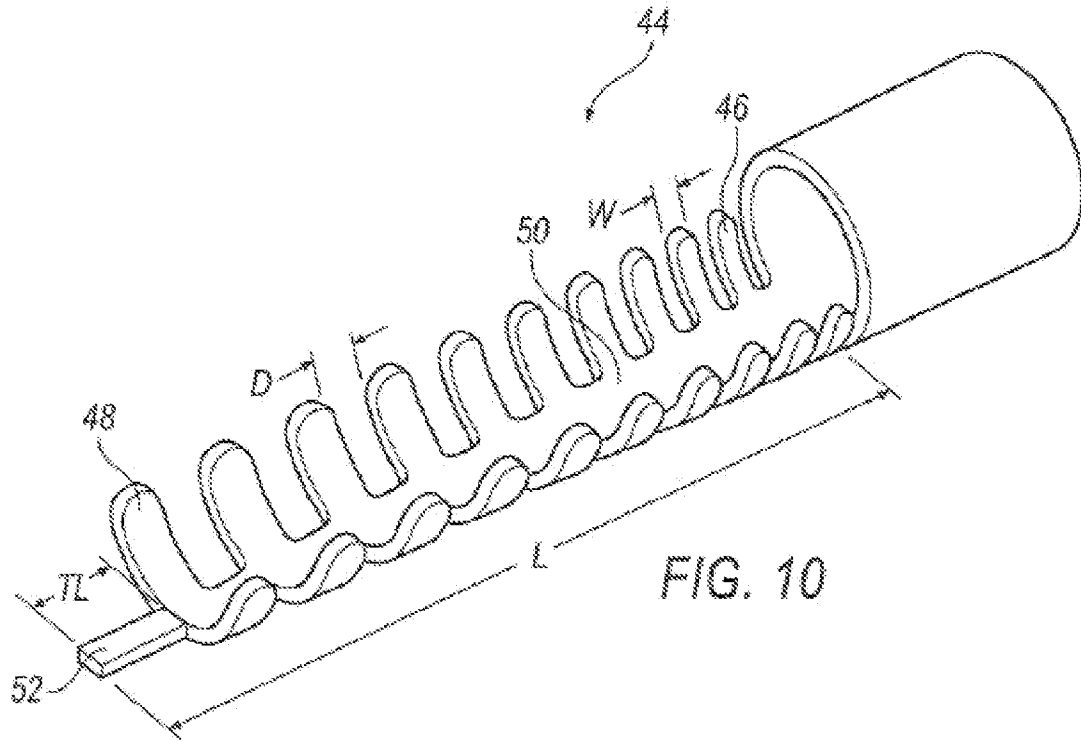
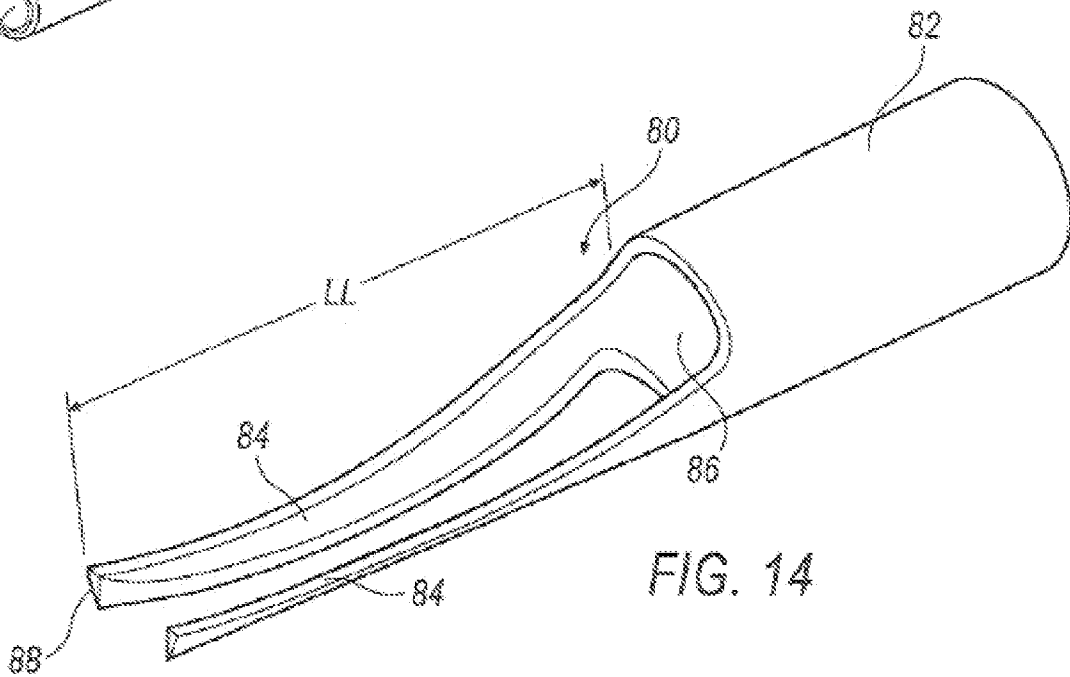
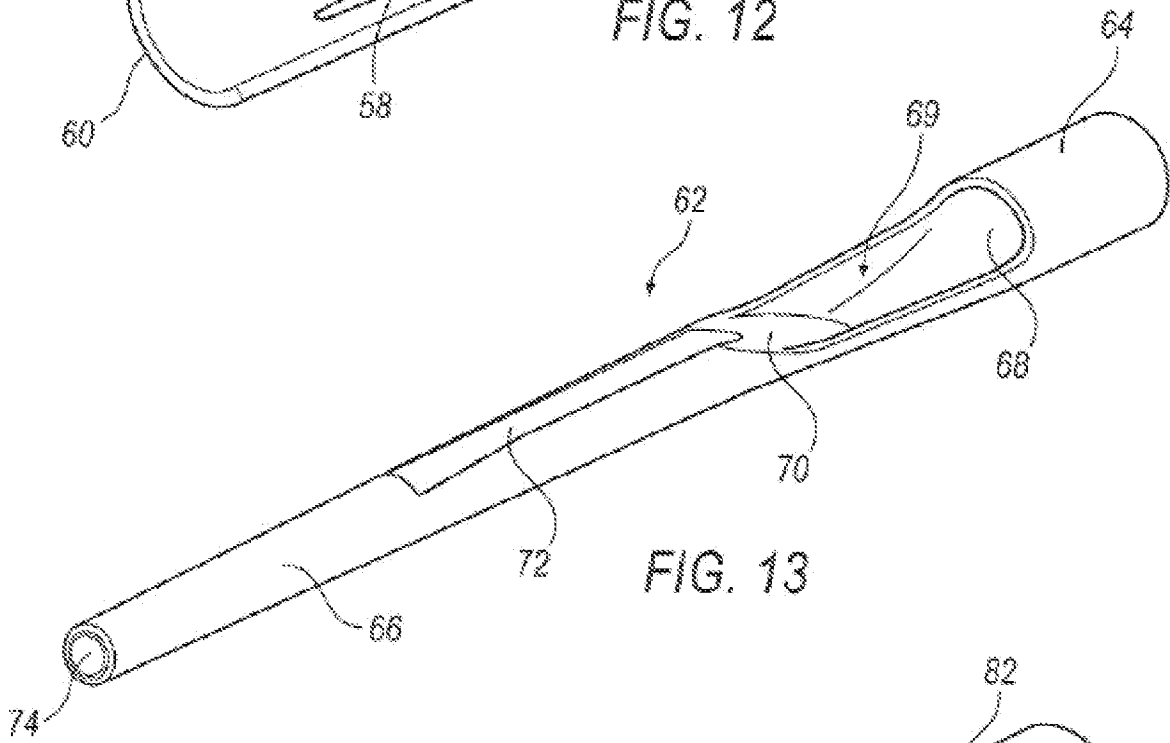
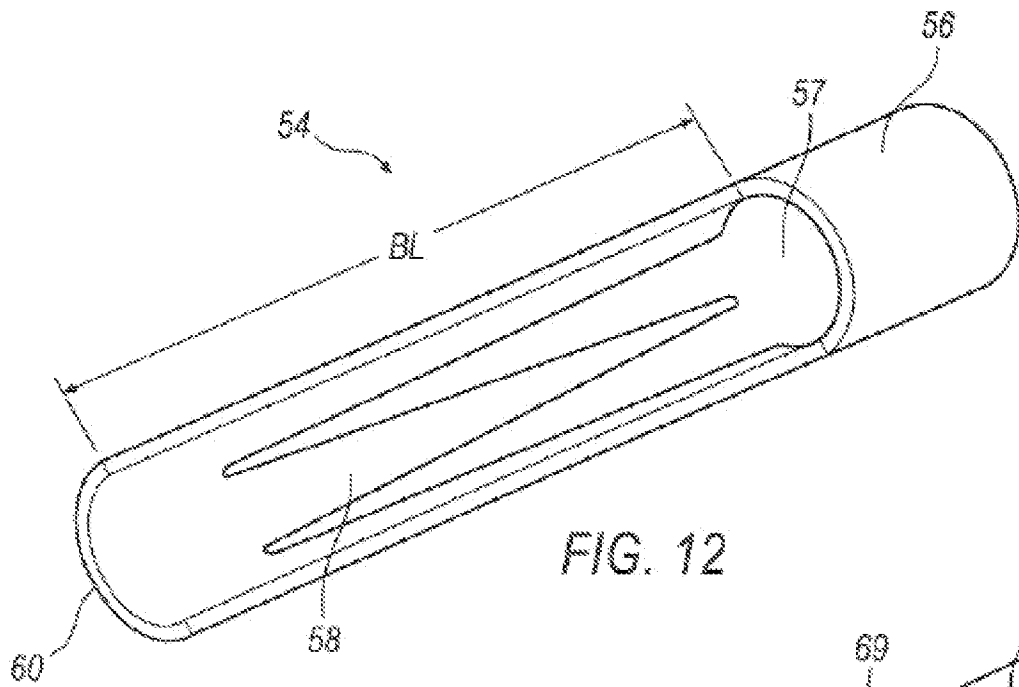

FIG. 9





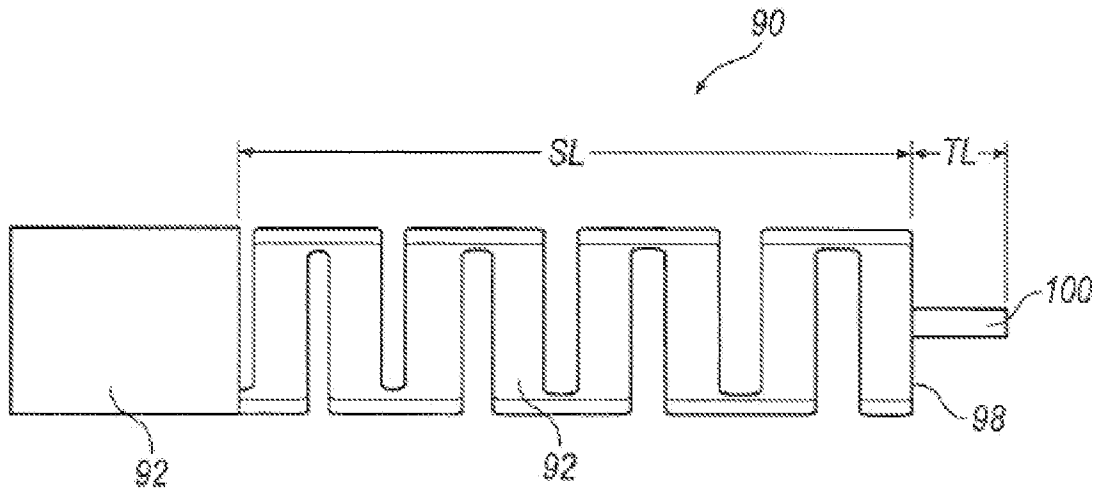

FIG. 15

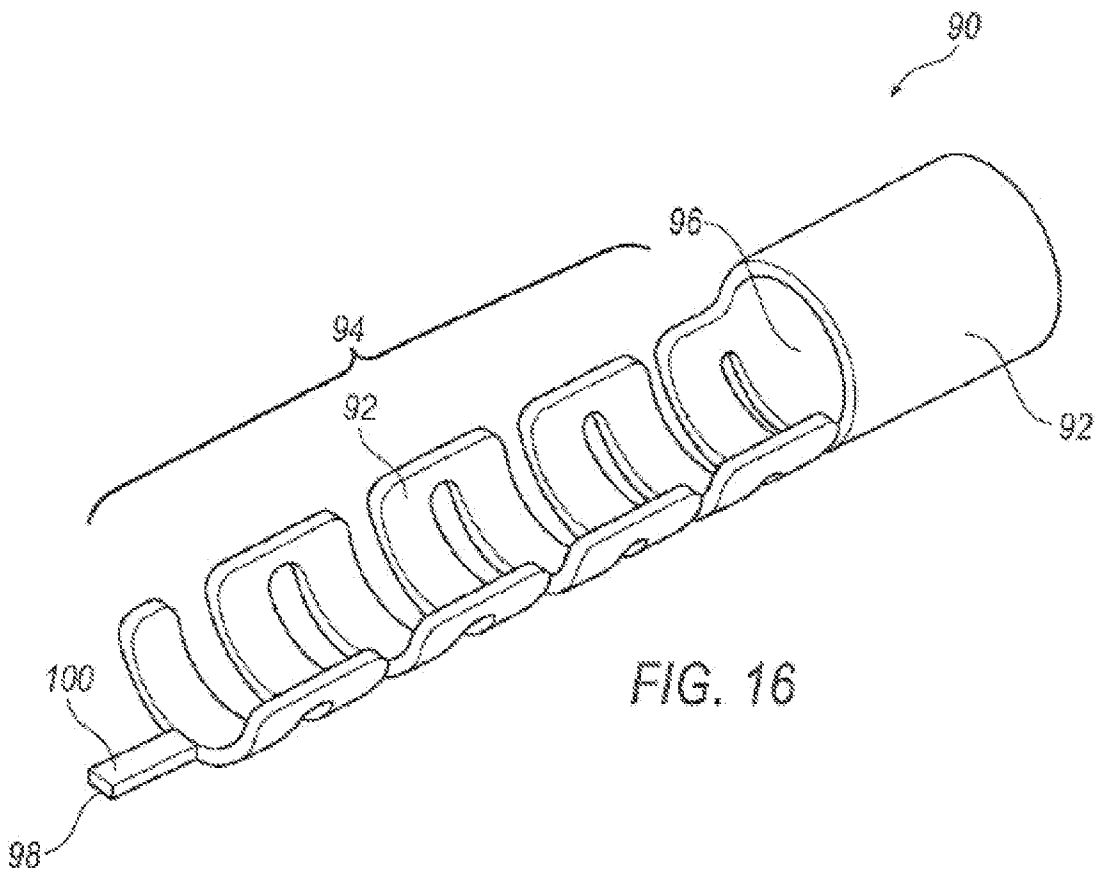

FIG. 16

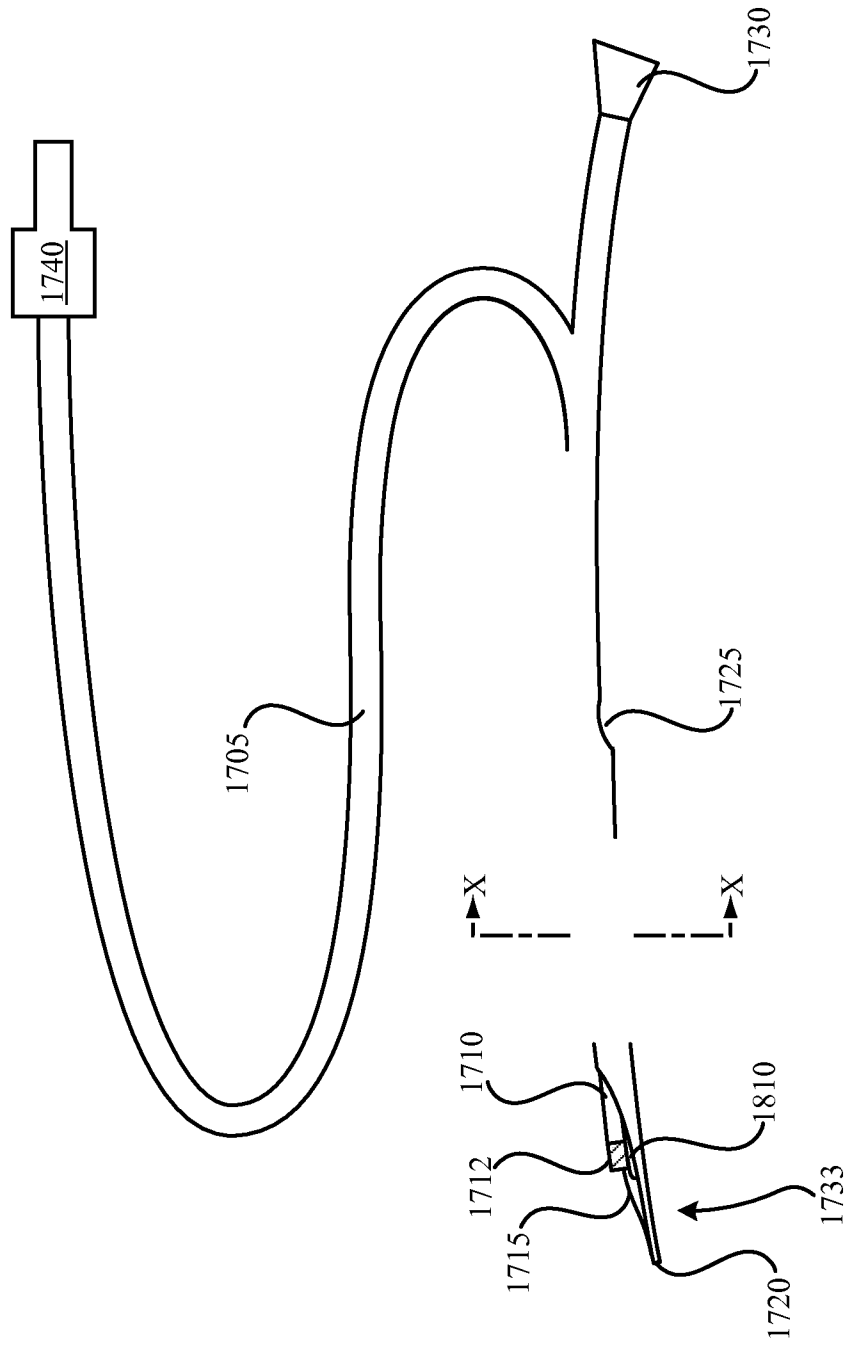

FIG. 17

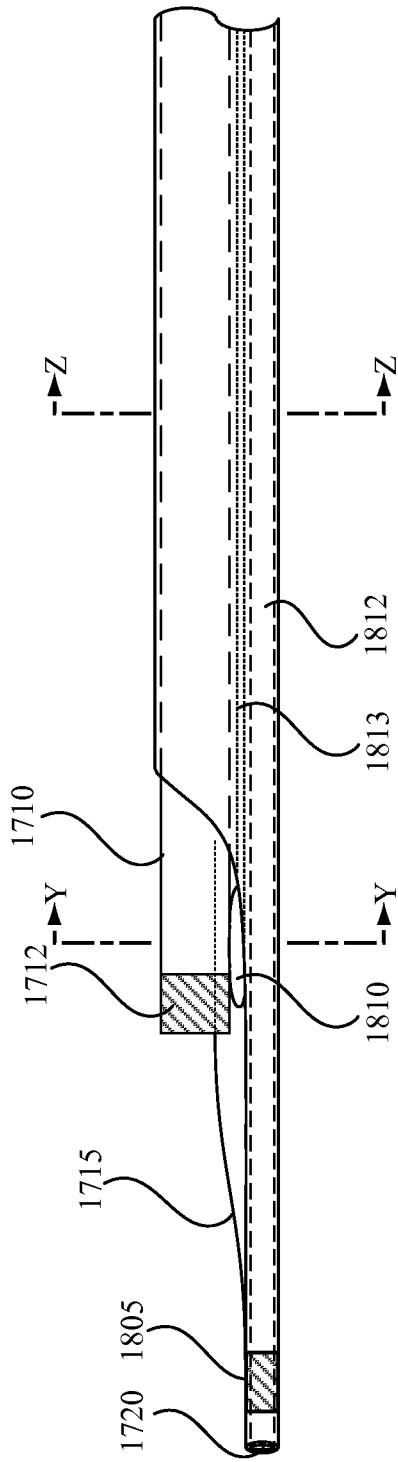

FIG. 18A

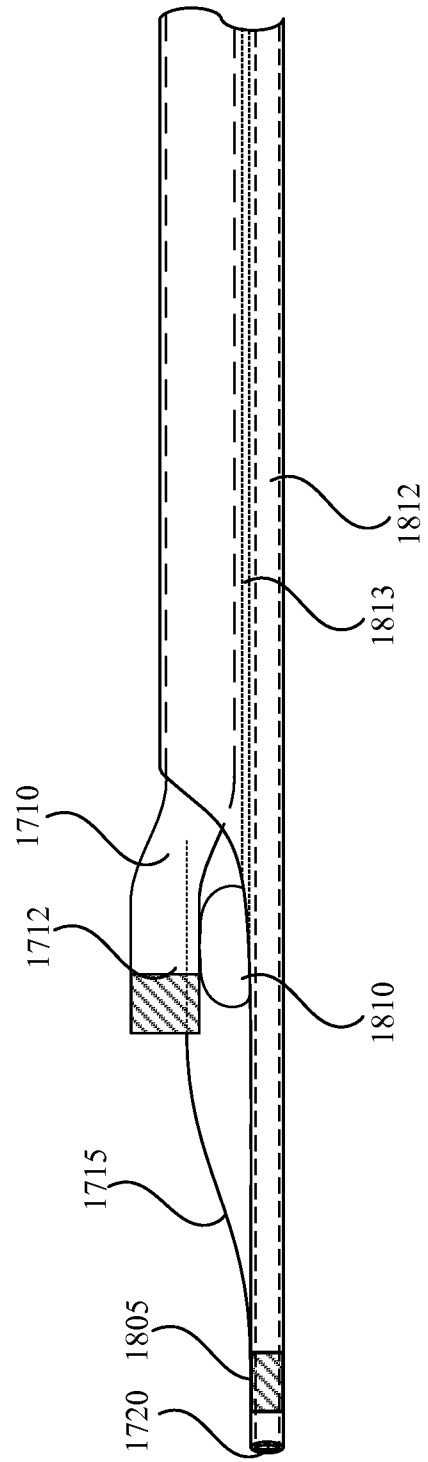

FIG. 18B

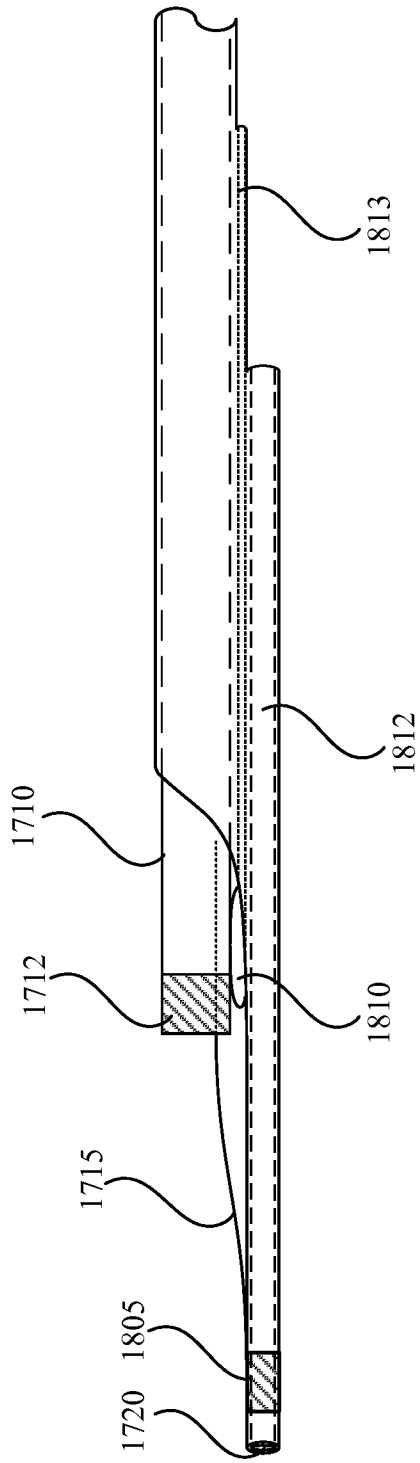

FIG. 18C

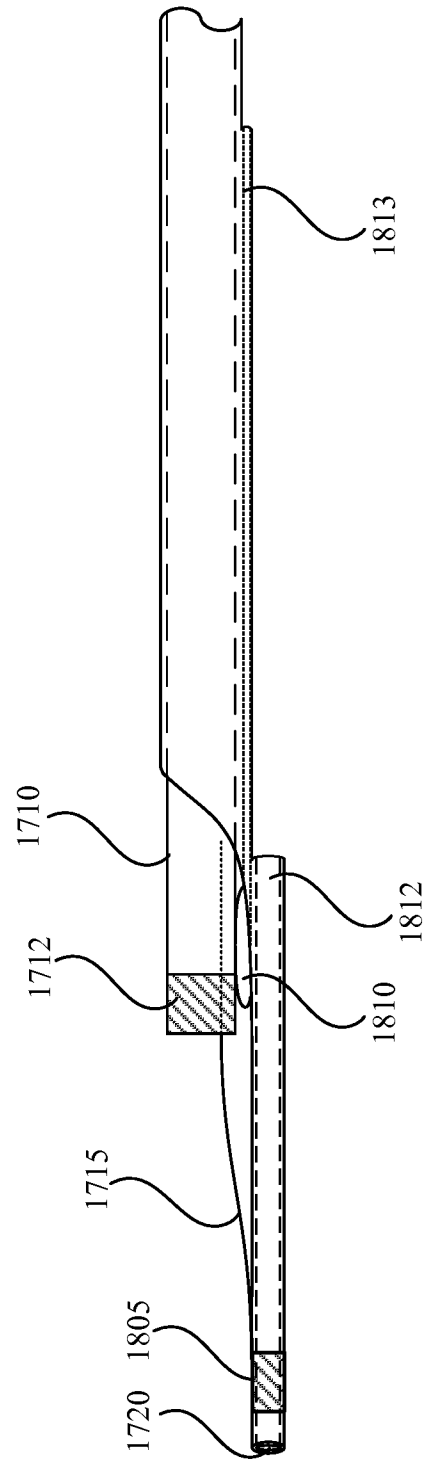

FIG. 18D

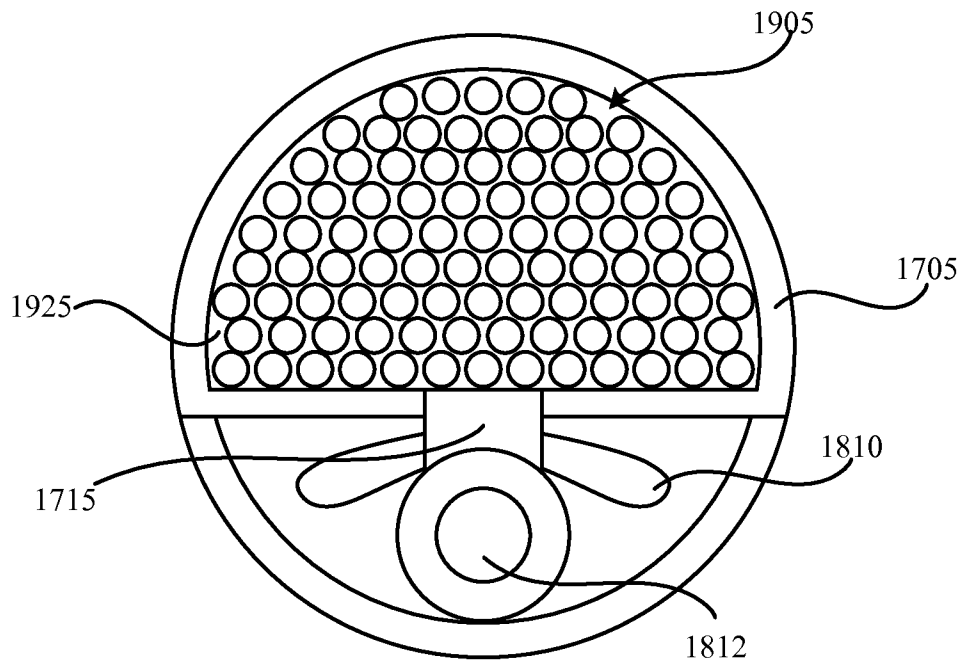

FIG. 19

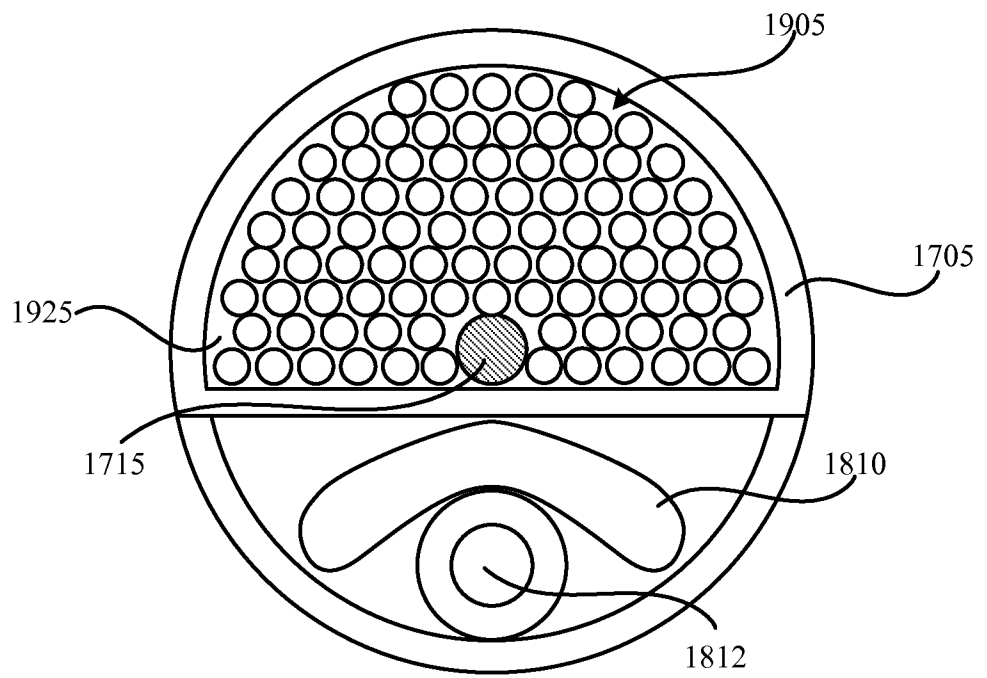

FIG. 20

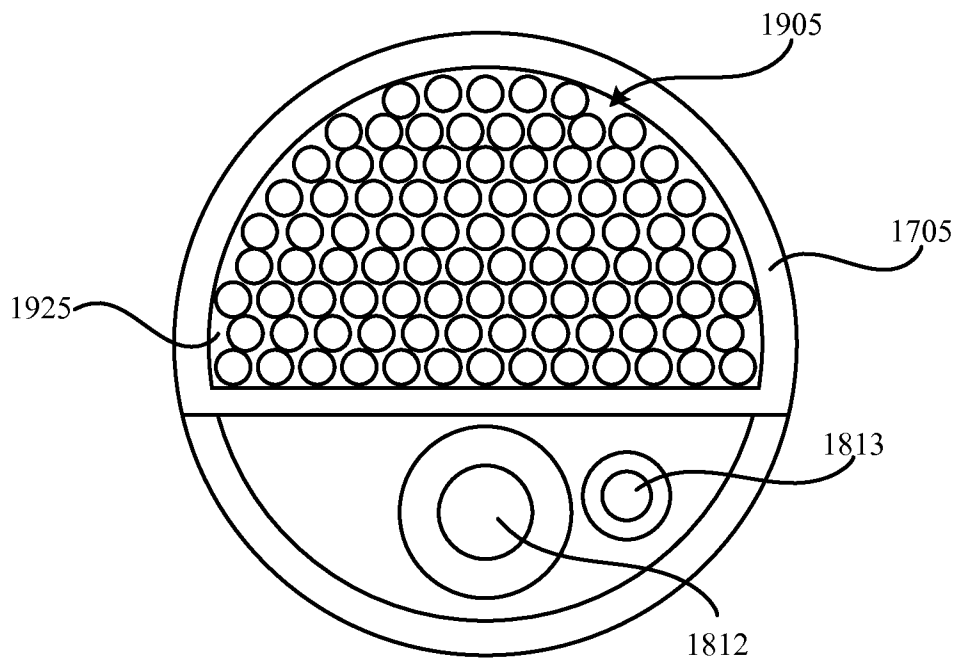
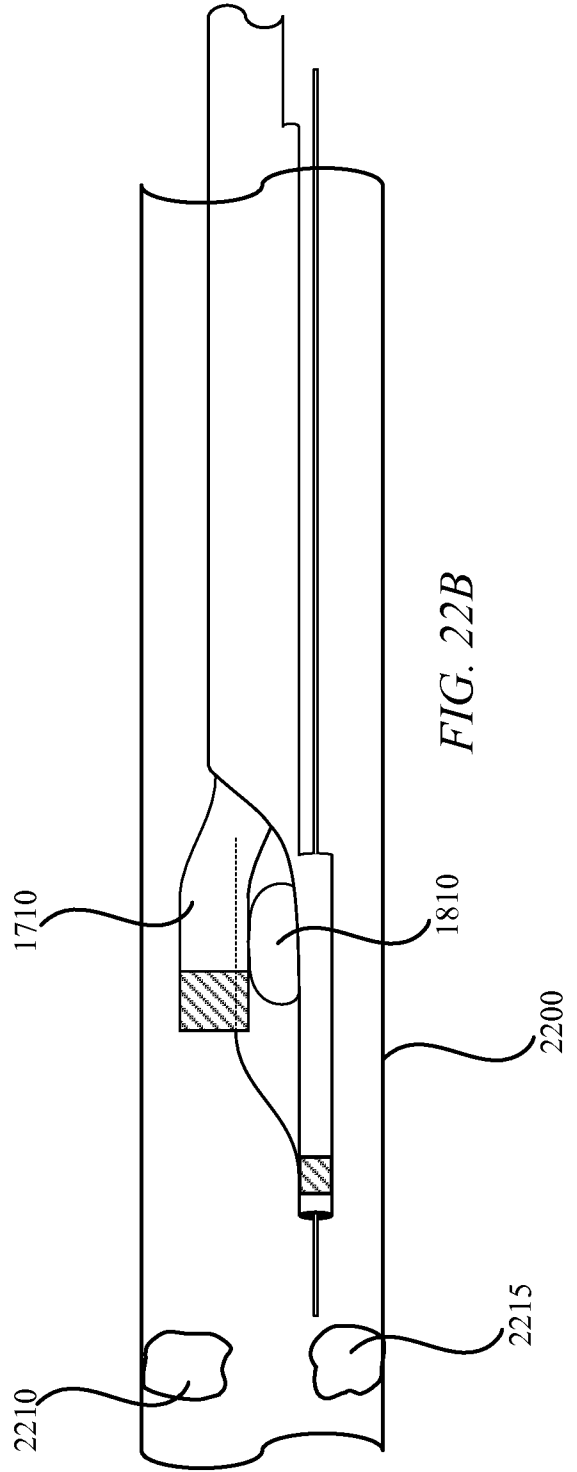
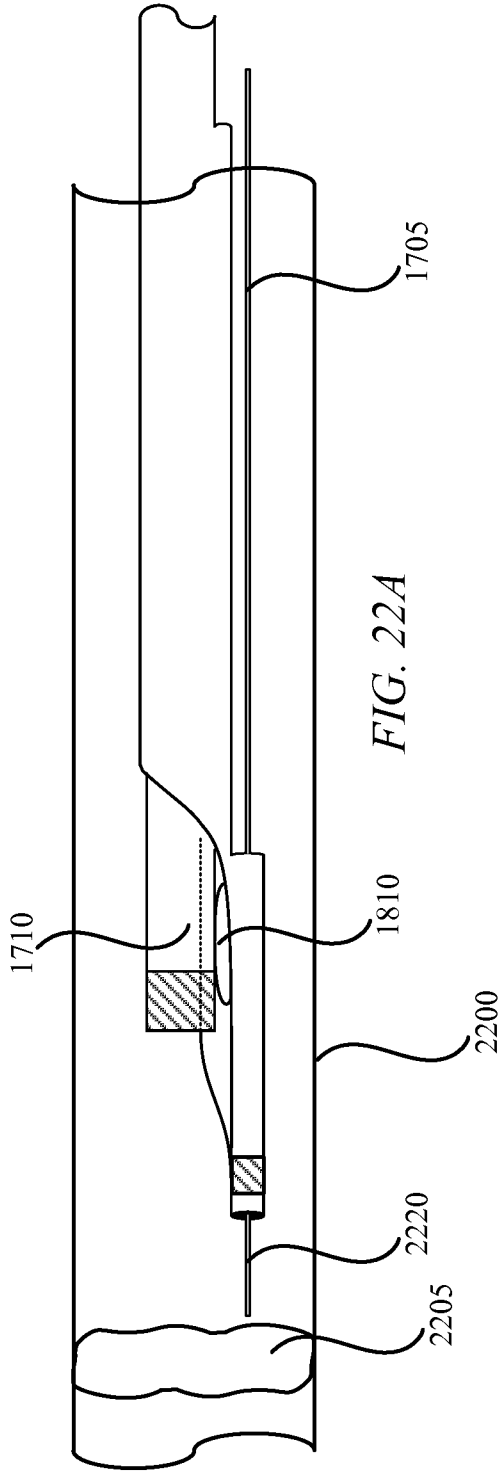

FIG. 21



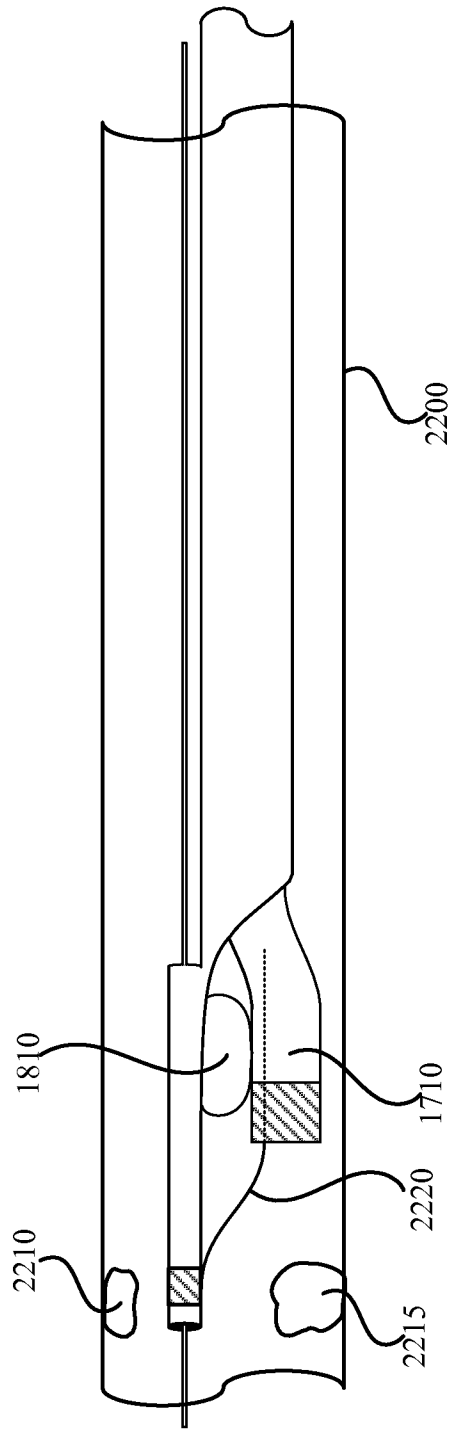

FIG. 22C

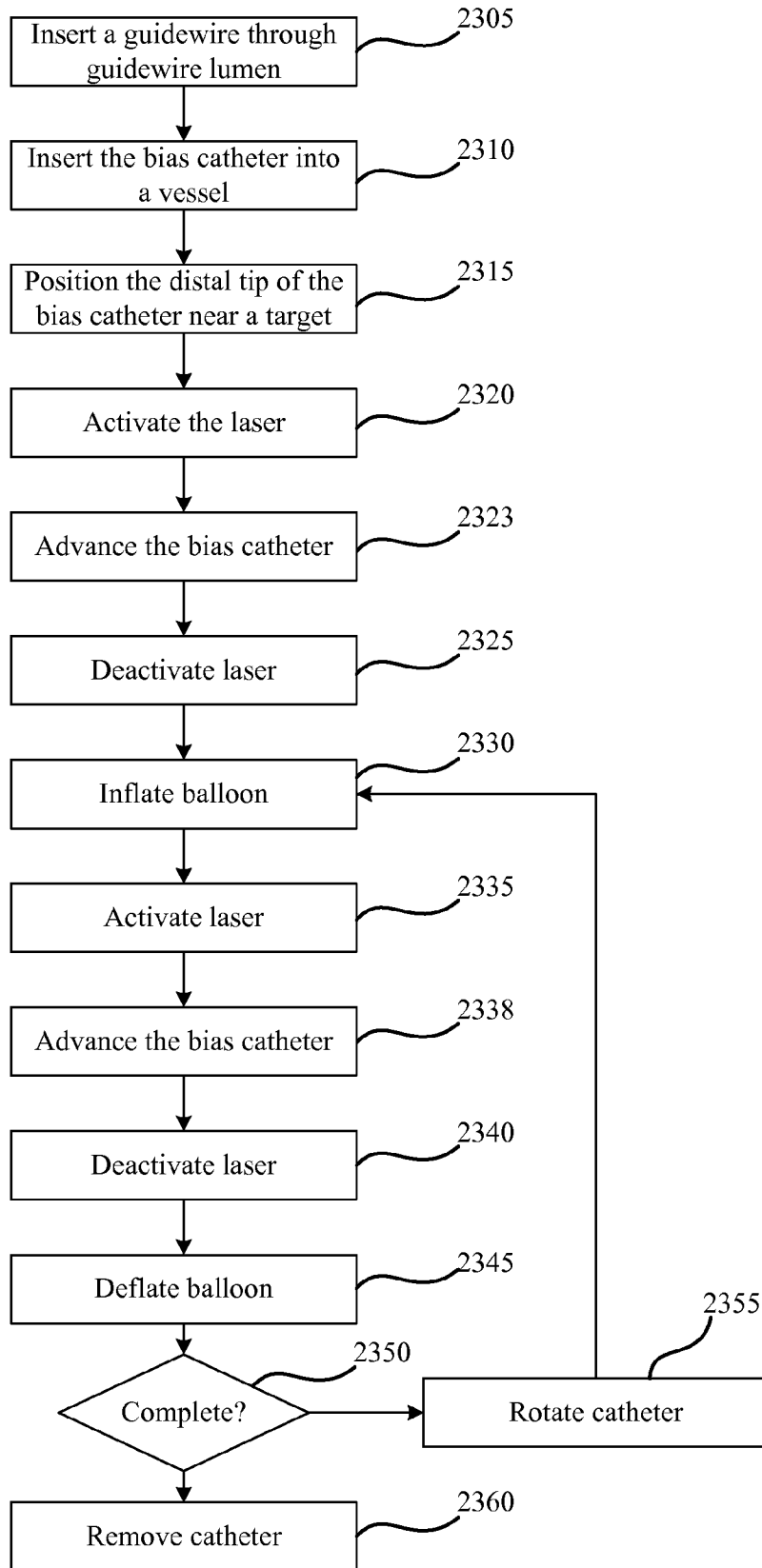

FIG. 23

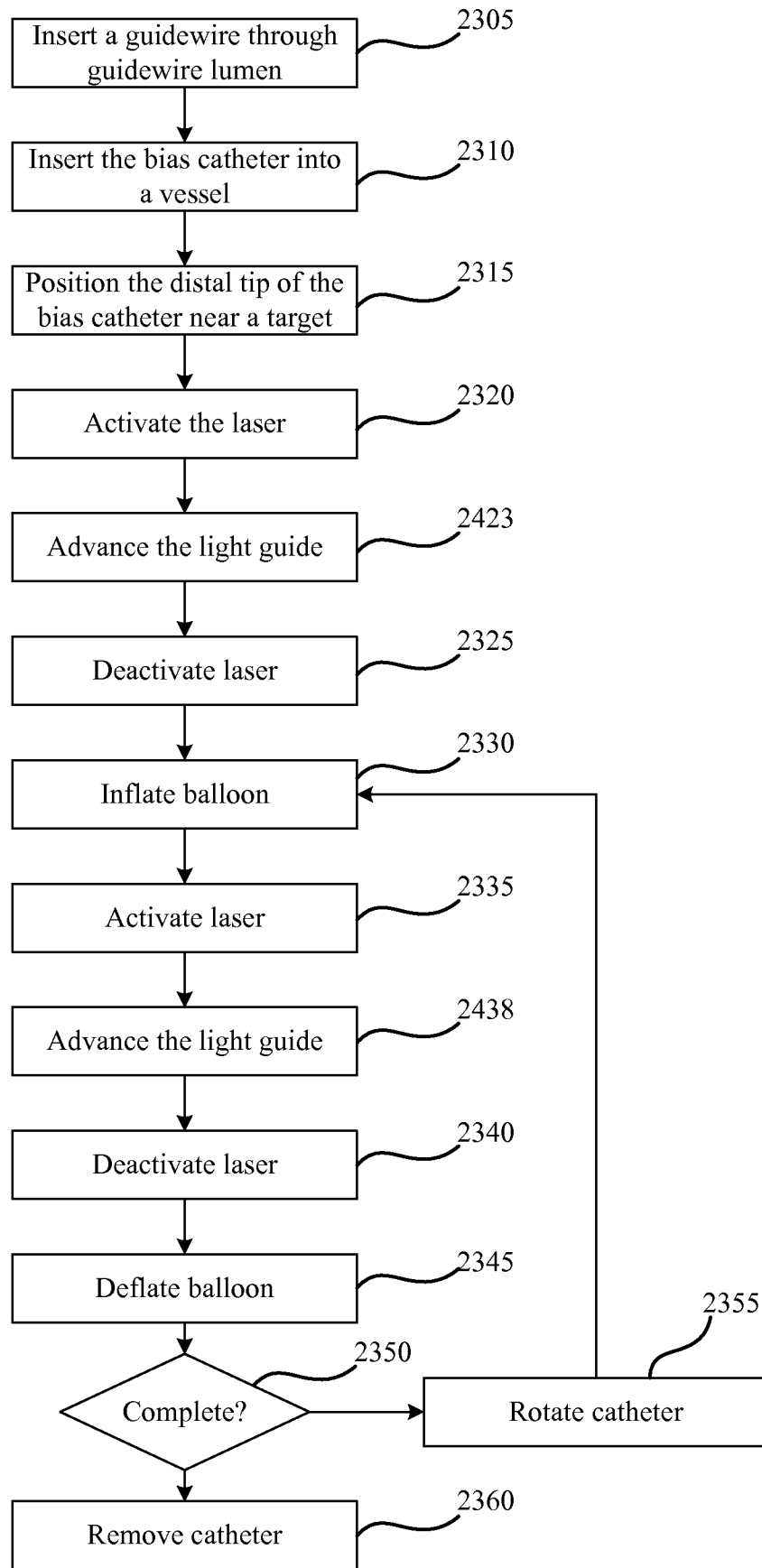

FIG. 24

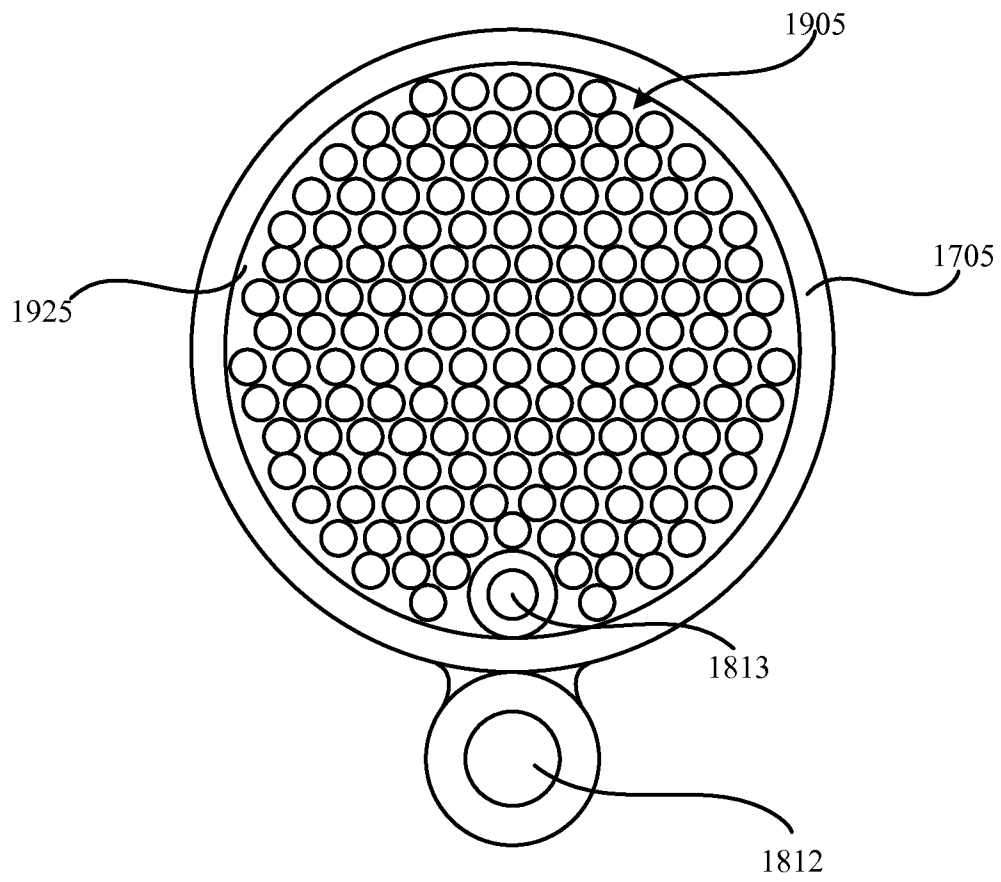

FIG. 25

INTERNATIONAL SEARCH REPORT

International application No.

PCT/US2009/066133

A. CLASSIFICATION OF SUBJECT MATTER

IPC(8) - A61B 18/18 (2010.01)

USPC - 606/7

According to International Patent Classification (IPC) or to both national classification and IPC

B. FIELDS SEARCHED

Minimum documentation searched (classification system followed by classification symbols)

IPC(8) - A61B 18/18 (2010.01)

USPC - 606/7, 14, 16-17; 607/89, 92-93

Documentation searched other than minimum documentation to the extent that such documents are included in the fields searched

Electronic data base consulted during the international search (name of data base and, where practicable, search terms used)

PatBase

C. DOCUMENTS CONSIDERED TO BE RELEVANT

Category*	Citation of document, with indication, where appropriate, of the relevant passages	Relevant to claim No.
X - Y	US 2006/0167442 A1 (HEBERT et al) 27 July 2006 (27.08.2006) entire document	1-2, 4-6, 15-18, 23-27, 32-34
		3, 7-14, 19-22, 28-31
Y	US 5,304,171 A (GREGORY et al) 19 April 1994 (19.04.1994) entire document	3
Y	US 5,024,234 A (LEARY et al) 18 June 1991 (18.06.1991) entire document	7-11
Y	US 5,484,433 A (TAYLOR et al) 16 January 1996 (16.01.1996) entire document	12, 14, 19-22, 28-31
Y	US 5,429,617 A (HAMMERSMARK et al) 04 January 1995 (04.01.1995) entire document	13
A	US 5,217,454 A (KHOURY) 08 June 1993 (08.06.1993) entire document	1-34
A	US 2003/0078566 A1 (ELLIOTT et al) 24 April 2003 (24.04.2003) entire document	1-34

 Further documents are listed in the continuation of Box C.

* Special categories of cited documents:

"A" document defining the general state of the art which is not considered to be of particular relevance

"E" earlier application or patent but published on or after the international filing date

"L" document which may throw doubts on priority claim(s) or which is cited to establish the publication date of another citation or other special reason (as specified)

"O" document referring to an oral disclosure, use, exhibition or other means

"P" document published prior to the international filing date but later than the priority date claimed

"T" later document published after the international filing date or priority date and not in conflict with the application but cited to understand the principle or theory underlying the invention

"X" document of particular relevance; the claimed invention cannot be considered novel or cannot be considered to involve an inventive step when the document is taken alone

"Y" document of particular relevance; the claimed invention cannot be considered to involve an inventive step when the document is combined with one or more other such documents, such combination being obvious to a person skilled in the art

"&" document member of the same patent family

Date of the actual completion of the international search

20 January 2010

Date of mailing of the international search report

26 JAN 2010

Name and mailing address of the ISA/US

Mail Stop PCT, Attn: ISA/US, Commissioner for Patents
P.O. Box 1450, Alexandria, Virginia 22313-1450

Facsimile No. 571-273-3201

Authorized officer:

Blaine R. Copenheaver

PCT Helpdesk: 571-272-4300

PCT OSP: 571-272-7774