

July 12, 1927.

1,635,617

T. HALL

RAISING AND TRAVERSING GEAR

Filed July 27, 1926

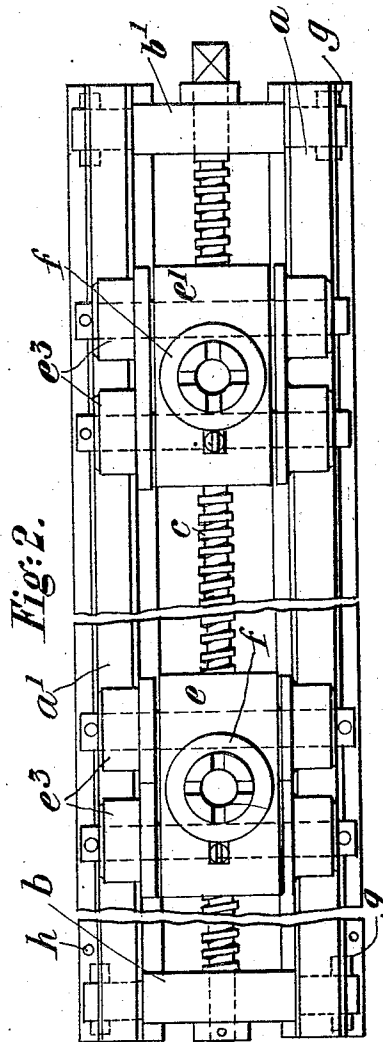
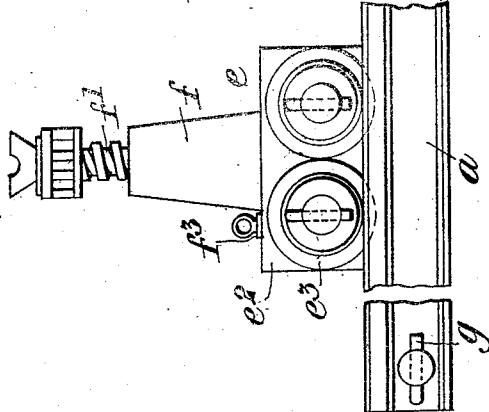
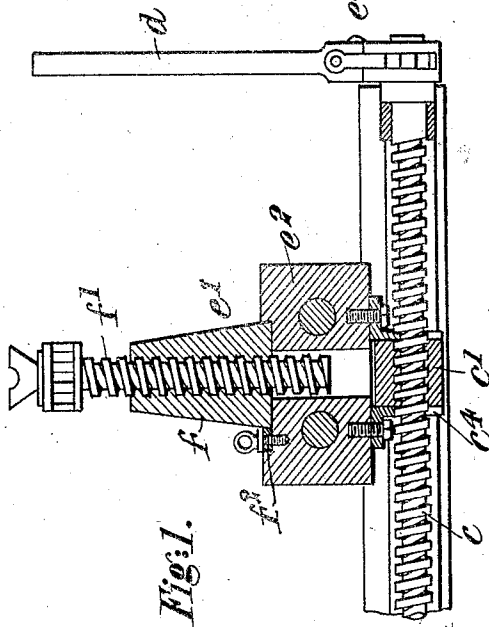
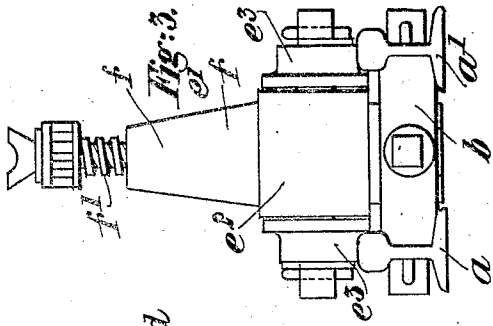

Inventor:
Thomas Hall.
By *Lucas Pinney* Attorney.

UNITED STATES PATENT OFFICE.

THOMAS HALL, OF MIDDLESBROUGH, ENGLAND.

RAISING AND TRAVERSING GEAR.

Application filed July 27, 1926, Serial No. 125,250, and in Great Britain July 25, 1925.

This invention relates to raising and traversing gear of the kind comprising a base carrying one or more carriages mounted for longitudinal movement along said base and adapted to carry lifting jacks, movement being imparted to the said carriages by means of a threaded shaft or screw mounted in the said base and engaging nuts on the said carriages.

The object of the invention is to provide means whereby the position of a carriage along the screw shaft, and more especially the relative position of a plurality of carriages, may be readily altered. Another object of the invention is to provide a compact apparatus which will be particularly adapted for use in restoring derailed trucks and the like to the rails of a railway track.

According to the invention the carriage nuts are associated with the carriages in such a manner that the carriages may be lifted away from the base so that the nuts may be moved separately along the shaft.

In a preferred form of construction the base comprises two rail lengths spaced apart, while the carriages comprise blocks mounted on rollers running on the said rail lengths.

The invention will now be described with reference to the accompanying drawing which shows an example of construction of the raising and traversing gear according to the present invention, particularly adapted for use in derailment operations.

In the said drawing:

Fig. 1 is a side elevation with parts in section,

Fig. 2 is a plan view of Fig. 1, and

Fig. 3 is an end view of Fig. 1.

Referring more particularly to the drawing, the base comprises two parallel lengths of rail, a , a^1 preferably flat bottomed, which are spaced apart at their ends by distance pieces b , b^1 detachably secured to the said rails, and which also serve as bearings to support a threaded shaft c running the whole length of the base, the end of the said shaft being shaped to receive a ratchet spanner d or a handle or the like.

Two carriages, e , e^1 are shown as provided, and these are in the form of rectangular blocks e^2 mounted on rollers e^3 running on the said rails a , a^1 . Underneath each carriage there is detachably secured a hollow bracket or cage e^4 which fits over a nut e^5 in threaded engagement with the shaft c , in such a manner that the nut is held against

turning. On the upper face of the carriage a recess is formed to receive the base of a lifting jack f while a central hole is formed through the carriage at the middle of the recess to receive the threaded shaft or screw f^1 of the jack, thus allowing for a relative large lifting range. The base of the jack is preferably round as also is the recess, the jack being held against turning movement by means of a spigot f^2 projecting from its base into a corresponding recess at the edge of the main recess. An eye bolt f^3 or the like may be provided for holding down the jack.

It will be seen that when the shaft c is turned, the two carriages will move along the rails at a uniform distance apart. In order that this distance may be varied expeditiously, or the position of the carriages otherwise changed, the cage e^4 underneath each carriage may be in the form of a flanged square box as shown having its top and bottom removed, the nut e^5 being of square section so as to fit inside the cage without the possibility of turning, while two opposite sides of the cage are slotted to receive the screw shaft. With this arrangement a carriage may be lifted off the rails altogether and its nut spun around until the desired position is reached, whereupon the carriage may be replaced.

In use, the apparatus is placed on the rails of the track underneath the derailed truck or the like, and where the truck is farther than usual from the rails one end of the base may have to be temporarily supported. The shaft c is then turned until the carriages e , e^1 with their jacks are underneath the sole or under frame of the truck which rests on the springs, whereupon the truck is jacked up until the wheels clear the rails. The shaft c is then turned until the wheels are over the track, and the jacks lowered until the wheels rest on the rails. If both pairs of wheels are off the rails, the operation is repeated for the other pair of wheels.

It will be seen that the only damage to the track as a result of using the apparatus according to the present invention occurs where both pairs of wheels are off the rails, in which case while the one pair is being angled into position the other pair acts as a pivot and thus tends slightly to enlarge any hole that has already been made by the wheels as they came off the rails.

To allow for portability, the securing

means between the rail lengths a , a' and the distance pieces b , b' are preferably in the form of cotters g so that the base, which is the heaviest part, may be readily assembled and disassembled, and this may be conveniently effected in situ if desired.

Holes are preferably drilled as at h along one of the flanges of each of the rails a , a' to receive bolts which project below the level of the rails to prevent the apparatus being slid off the permanent way.

The apparatus according to the present invention is adapted for all manner of uses where a vertical and horizontal movement are required, and particularly where space is restricted, for example in the case of railway work, where a derailment occurs at a sharp bend which precludes the use of the usual crane, or at crossings where it is impossible to use ramps and short rails.

What I claim as my invention and desire to secure by Letters Patent of the United States is:—

1. Raising and lowering gear comprising in combination a trackway, a carriage movable along the trackway and freely liftable bodily off the same, a jack on the carriage, a threaded shaft mounted longitudinally in the trackway, a nut adapted to travel on said shaft, and a cage secured to the base of the carriage and wherein the nut is disposed when said carriage is in place on the trackway, but which is withdrawn directly from said nut when the carriage is lifted.

2. Raising and lowering gear comprising in combination a trackway, a carriage movable along the trackway and freely liftable bodily off the same, a jack on the carriage, a threaded shaft mounted longitudinally in the trackway, a nut adapted to travel on said shaft, and a cage secured to the base of the carriage and wherein the nut is disposed when said carriage is in place on the trackway, but which is withdrawn directly from said nut when the carriage is lifted, said cage acting to hold the nut itself against rotation when engaged therewith.

3. Raising and lowering gear comprising in combination a trackway, a carriage movable along the trackway and freely liftable bodily off the same, a jack on the carriage, a threaded shaft mounted longitudinally in the trackway, a nut adapted to travel on said shaft, and a cage secured to the base of the carriage and wherein the nut is disposed when said carriage is in place on the trackway, but which is withdrawn directly from said nut when the carriage is lifted, said cage having oppositely-located slots to receive and release said shaft alternatively.

4. Raising and lowering gear comprising in combination a trackway, a carriage movable along the trackway and freely liftable bodily off the same, a jack on the carriage, a threaded shaft mounted longitudinally in the trackway, a nut adapted to travel on said shaft, and a cage secured to the base of the carriage and wherein the nut is disposed when said carriage is in place on the trackway, but which is withdrawn directly from said nut when the carriage is lifted, said cage acting to hold the nut itself against rotation when engaged therewith and having oppositely-located slots to receive and release said shaft alternatively.

5. Raising and lowering gear comprising in combination a trackway, a carriage movable along the trackway and freely liftable bodily off the same, a jack on the carriage, a threaded shaft mounted longitudinally in the trackway, an open cage of polygonal cross-section secured to the base of the carriage, and a polygonal nut on said shaft fitting removably within said cage when said carriage is in place on the trackway so as to be held against rotation by the cage but adapted to travel on the shaft when the latter is rotated, said cage being withdrawn directly from said nut when the carriage is lifted.

In witness whereof I have signed this specification.

THOMAS HALL.