

J. ROSENKRANZ.
Corn-Planter.

No. 197,178.

Patented Nov. 13, 1877.

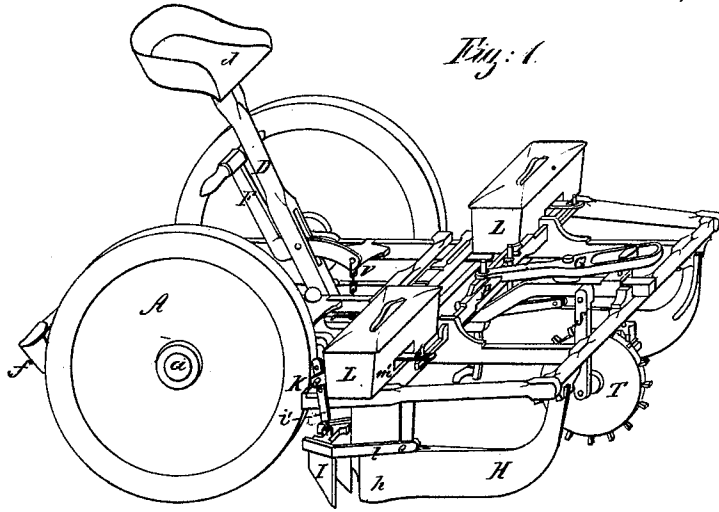
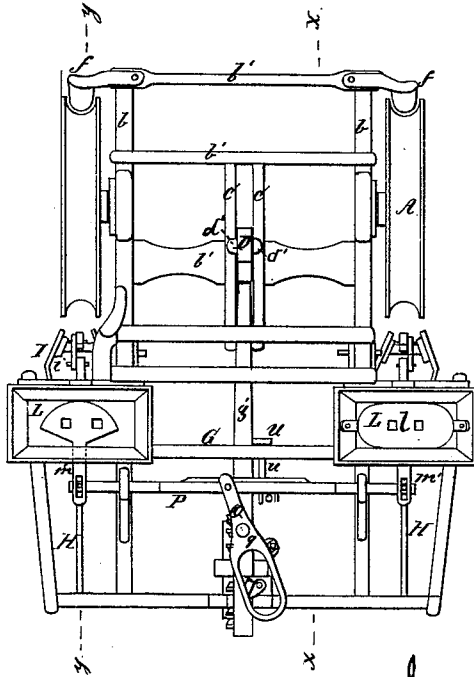

Fig. 1.

Fig. 2.



Witnessed.
L. H. Drey
Saml. R. Scharf

Inventor.
Jean Rosenkranz
by Geo. W. Dwyer
attys.

J. ROSENKRANZ. Corn-Planter.

No. 197,178.

Patented Nov. 13, 1877.

Fig: 3

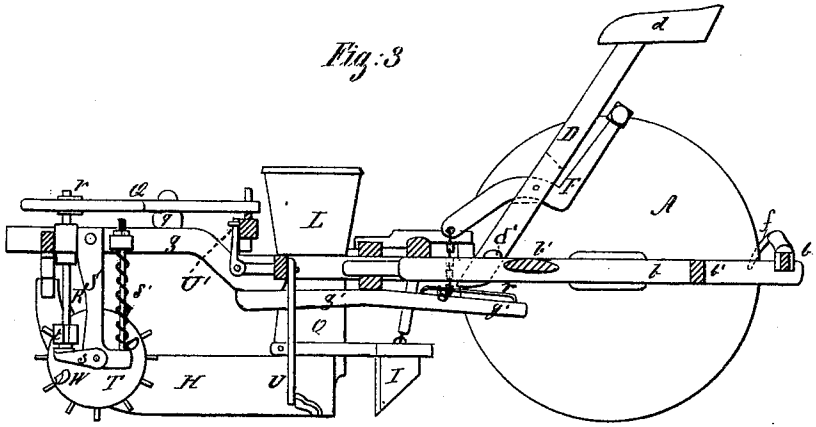

Fig: 4

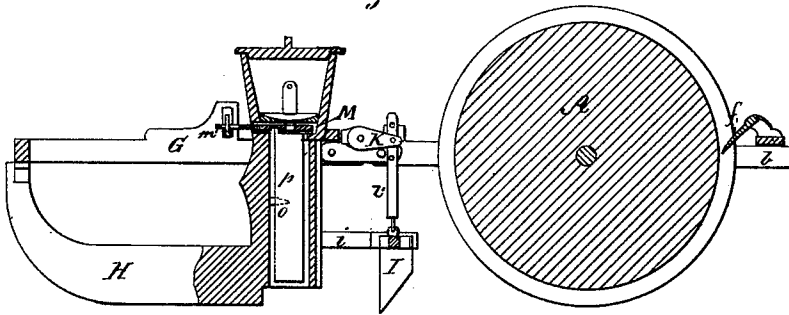

Fig: 5.

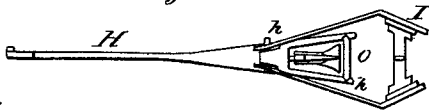

Fig: 6.

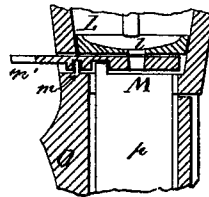

Fig: 7

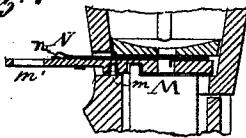
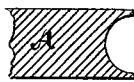

Fig: 8.



Witnessed.
L. M. Dwyer
Samuel R. Scharf

Inventor
Jean Rosenkrantz
 by *Geo. W. Dyarke*
Atty

UNITED STATES PATENT OFFICE.

JEAN ROSENKRANZ, OF ALLAN TOWNSHIP, LA SALLE COUNTY, ILLINOIS.

IMPROVEMENT IN CORN-PLANTERS.

Specification forming part of Letters Patent No. **197,178**, dated November 13, 1877; application filed August 24, 1877.

To all whom it may concern:

Be it known that I, JEAN ROSENKRANZ, of Allan township, (Streator P. O.,) in the county of La Salle and State of Illinois, have invented certain Improvements in Corn-Planters, of which the following is a full and exact description, reference being had to the accompanying drawings, in which—

Figure 1 is a perspective view of my improved implement. Fig. 2 is a top view of the same. Fig. 3 is a longitudinal section on line *x x* in Fig. 2. Fig. 4 is a similar view on line *y y* in Fig. 2. Fig. 5 is a bottom view of one of the runners. Fig. 6 is an enlarged longitudinal section of one of the feed-boxes. Fig. 7 is a similar view of the same, showing the adjustment of the grain-feed valve-holes; and Fig. 8 is a section of the rim of the traction-wheel.

The nature of my invention relates to the construction of a so-called "self-dropping check-row corn-planter;" and it consists, first, in the peculiar combination of devices for dropping the seed; and, second, in the peculiar arrangement for balancing the machine and for raising the runners off the ground, as more fully hereinafter set forth.

In the accompanying drawings, A represents the traction-wheels, having broad concave rims for the purpose of tightening the ground upon the seed, and being mounted on axle-spindles *a*, which are secured to the side beams of frame B.

The frame B consists of two side bars, *b*, girts *b'*, and two central longitudinal bars, C. D is the standard upon which the seat *d* for the driver is mounted. This standard is supported between the bars C by a bolt, *d'*, passed through said standard, and having oblong heads, which rest upon the bars C, and is held in an upright position by having projecting shoulders to its bottom end leaning against the bottom side of said bars, thus permitting the standard to be shifted forward or backward for balancing the machine by the weight of the driver. The central portion of said standard D is slotted for admitting the lever F, which is pivoted therein. Scrapers *f* are secured upon the ends of the rear girt *b'* for cleaning the wheels A of any clay adhering thereto. The front ends of the side beams *b* are pivoted

to the frame G, which carries the operating parts of the machine.

H are runners secured to the front ends of the frame, which terminate in furrow-openers *h* for drawing a furrow, into which the seed is dropped. The two small plows I, which follow each of the furrow-openers, are intended to cover the grain with loose earth, and make a small ridge on the row, to be packed by the traction-wheels while passing over. These plows are coupled to the feed-spouts by links *i*, and each pair is adjustably suspended by a rod, *i'*, to a crank, *k*, which is secured by a screw or bolt to a lug on frame G.

L are the feed-grain boxes upon the sides of frame G, having each a concave bottom with two feed-holes, *l*, in it, below which the dropper-valve M is pivoted, at *m*, having arm *m'*, by which is imparted to it an oscillating motion. This dropper-valve has two seed-holes, placed so in relation with the holes *l* of the feed-grain boxes that with each oscillation of the valve alternately one or the other feed-hole will be opened.

The size of the holes in valve M can be varied by a plate, N, having corresponding holes, and being arranged to slide upon said valve, and to be adjustably secured upon it at any desirable point by its hook-shaped end *n* being lodged into one of a series of serratures which are provided on top of valve-arm *m'*. This arrangement will have the advantage that the feed can be regulated from the outside of the machine, and without the waste of time of having the machine to take apart.

The dropper-spouts O, which guide the seed into the furrow, are pendent from under the grain-boxes, and terminate between the furrow-openers *h*, and have each a tongue, *p*, pivoted at *o*, whose upper end is coupled to the bottom of valve M. This tongue receives a vibrating movement at each oscillation of the valve, whereby its lower lipped end will catch and hold the grain, and release and drop it again on the next following movement, and will also prevent the seed from clogging in the spout.

The oscillation of the valves M is effected in the following manner: The arms *m'* of both valves M are connected by a rod, P, being

placed in guides upon frame G, and having a stud in its middle, which enters a slot in the end of a lever, Q, pivoted at *g* upon the frame, and having an oval-shaped slotted end, in which a crank, *r*, is rotating. This crank *r* is secured to the upper end of an upright spindle, R, which is pivoted to the central beam or wagon-pole *g* of frame G, and in a step-bearing piece *s*, which is adjustably bolted to one of the pendent brackets S, and counterpoised by a spiral spring, *s'*. A four-toothed pinion, *t*, is fixed upon the lower portion of spindle R. Wheel T, having a toothed rim for entering the ground and causing the said wheel to turn, is pivoted between the brackets S, to the face of which are attached two lugs or teeth, W, opposite to each other, to engage with the pinion *t*, and impart to the same an intermittent one-quarter revolution for each half-revolution of wheel T, so that a single movement is imparted to the lever Q with each revolution of the wheel T.

U is the marker, which is placed centrally between and in line with the dropper-spouts O. It consists of an arm, the upper end of which is secured upon one end of a rocking-shaft, *u*, journaled into the frame G, and having pivoted to its opposite end an arm, U', the upper end of which is engaged between two horizontally-projecting studs of rod P. The reciprocating motion of this rod will impart a pendulous motion to said lever, which will mark the ground directly opposite where the grain is dropped, so that the next row can be dropped to correspond, thereby insuring check and straight rows, and avoiding the necessity

of marking off the ground before commencing to plant.

The lever U' being hinged to the end of rocker-shaft *u*, it can be retracted, and thereby disengaged from the rod P.

The beam *g*, which is part of the wagon-pole, has a rearward-extension bar, *g'*, to the upper side of which is fixed an iron bar, *v*, to which the end of a chain, V, is linked, its opposite end being coupled to the end of lever F. By this arrangement the chain V can slide on the bar *v*, and can accommodate itself to the position of the seat-standard D. By means of the lever F the operating portion can be lifted to clear the ground while the machine is turned or transported.

What I claim as my invention is—

1. In combination with the feed-grain boxes L, having oscillating valves M, and dropper-spouts O, having tongues *p*, the rod P, lever Q, shaft R, with crank *r* and pinion *t*, and wheel T, all constructed and arranged within a frame, G, having runners H and plows I, substantially as described, to operate as specified.

2. The combination, with the frame B and adjustable seat-standard D, of the lever F, pivoted in the said seat-standard, the extension *g'* of the front frame, the rod *r*, and chain V, whereby the position of the seat-standard and its seat can be changed without interfering with the operation of the lever F, substantially as described and shown.

JEAN ROSENKRANZ.

Witnesses:

ADAM BERGE,
JOHN BERGE.