



(19) **United States**

(12) **Patent Application Publication**
INOUE et al.

(10) **Pub. No.: US 2001/0027804 A1**

(43) **Pub. Date: Oct. 11, 2001**

(54) **BUILDING MATERIAL, CLADDING ASSEMBLY, METHOD OF INSTALLING BUILDING MATERIAL, AIR FLOWING APPARATUS AND GENERATOR**

(30) **Foreign Application Priority Data**

Jun. 16, 1997 (JP)..... 158698/1997

Publication Classification

(75) **Inventors:** YUJI INOUE, NARA-SHI (JP);
ICHIRO KATAOKA, KYOTO (JP);
FUMITAKA TOYOMURA, KYOTO (JP);
SATORU SHIOMI, KYOTO (JP);
MAKOTO SASAOKA, KYOTO (JP)

(51) **Int. Cl.⁷** **E04H 14/00**

(52) **U.S. Cl.** **136/256**

(57) **ABSTRACT**

The present invention provides a building material with a solar cell having a solar cell unit fixed to a substrate, and an electrical conductive lead for leading output from the solar cell unit to the outside, wherein a jacket material of the electrical conductive lead is composed of at least one selected from the group consisting of polyethylene resins, polyamide resins, vinylidene fluoride resins, chloroprene rubber, ethylene-propylene rubber, silicone resins. The present invention also provides a cladding assembly including the building material fixed to the backing material by a fixing member, and the electrical conductive lead arranged between the building material and the backing material to contact the backing material, for leading output from the solar cell unit to the outside, wherein the backing material contains any one of an asphalt resin, a vinyl chloride resin, a polystyrene resin, and a polyurethane resin. Therefore, the long-term reliability of the cladding assembly having the electrical conductive lead of the solar cell unit, which is laid directly on the backing material, is improved.

Correspondence Address:

FITZPATRICK CELLA HARPER & SCINTO
30 ROCKEFELLER PLAZA
NEW YORK, NY 10112 (US)

(73) **Assignee: Justin J, Oliver**

(*) **Notice:** This is a publication of a continued prosecution application (CPA) filed under 37 CFR 1.53(d).

(21) **Appl. No.: 09/096,515**

(22) **Filed: Jun. 12, 1998**

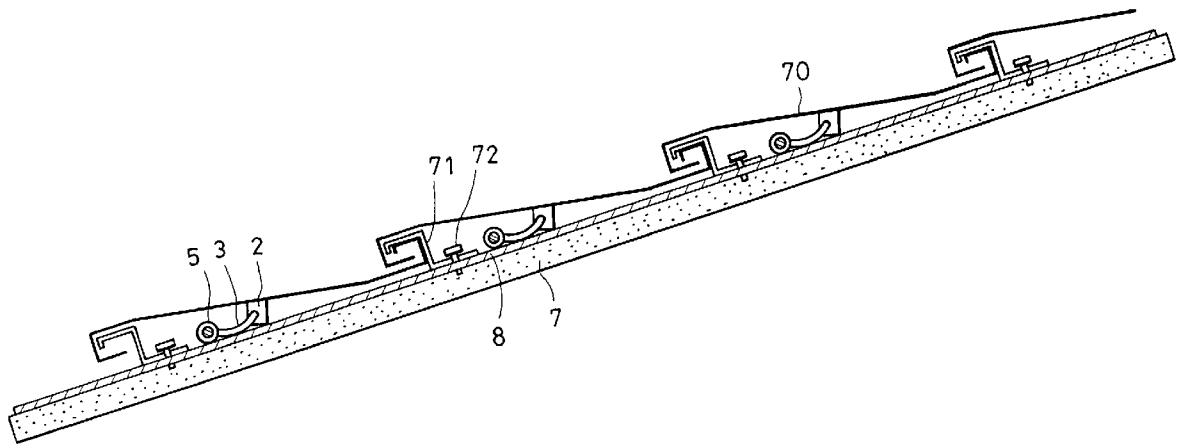
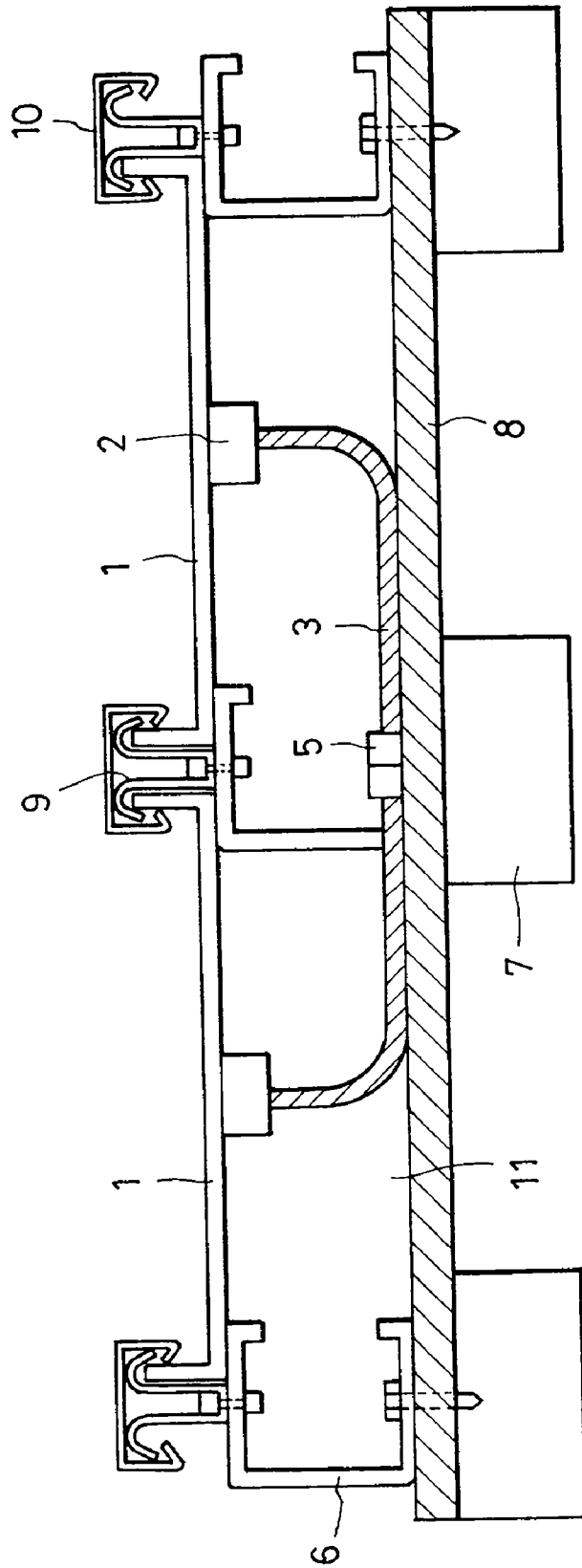

FIG. 1



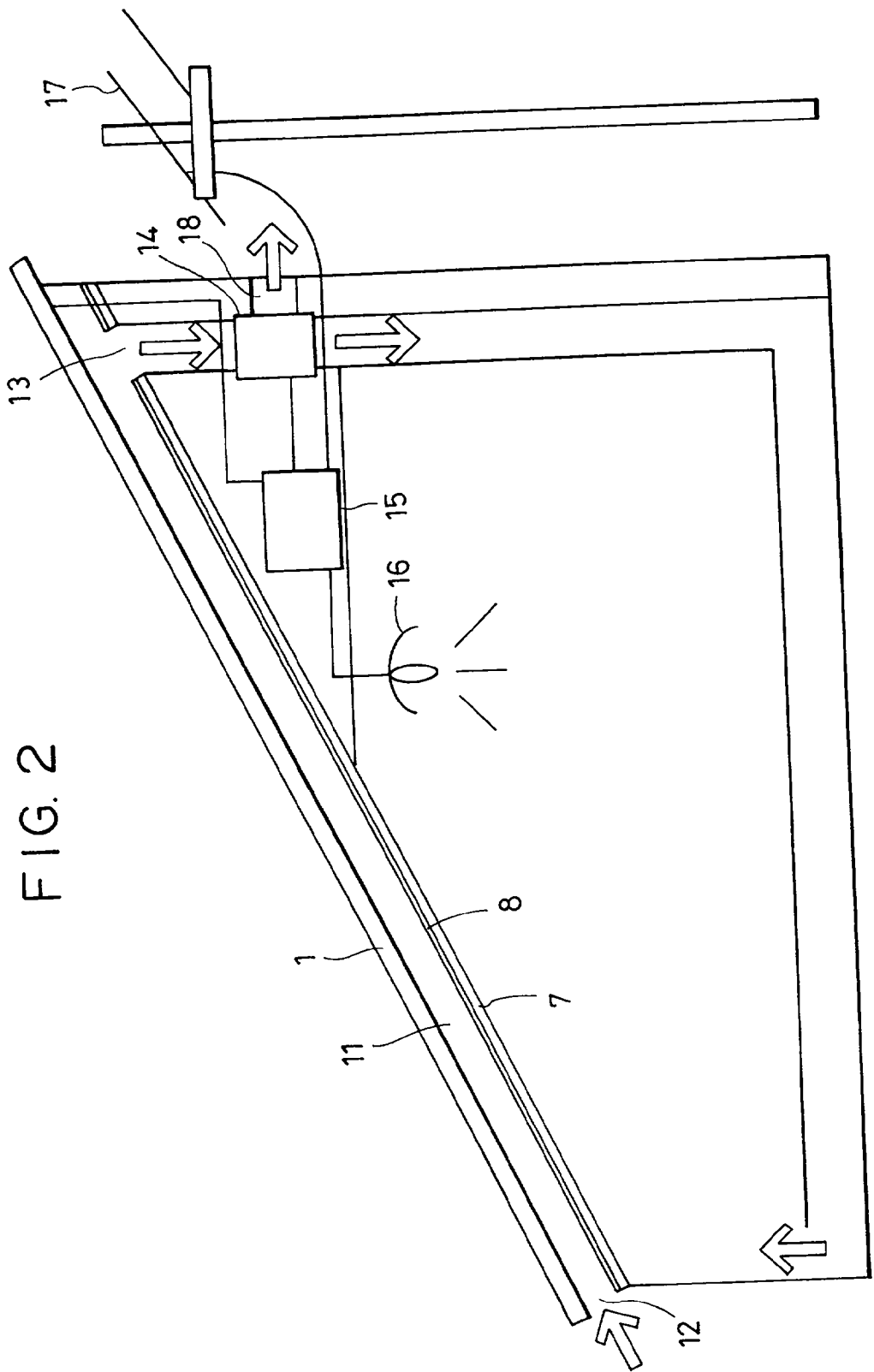

FIG. 3

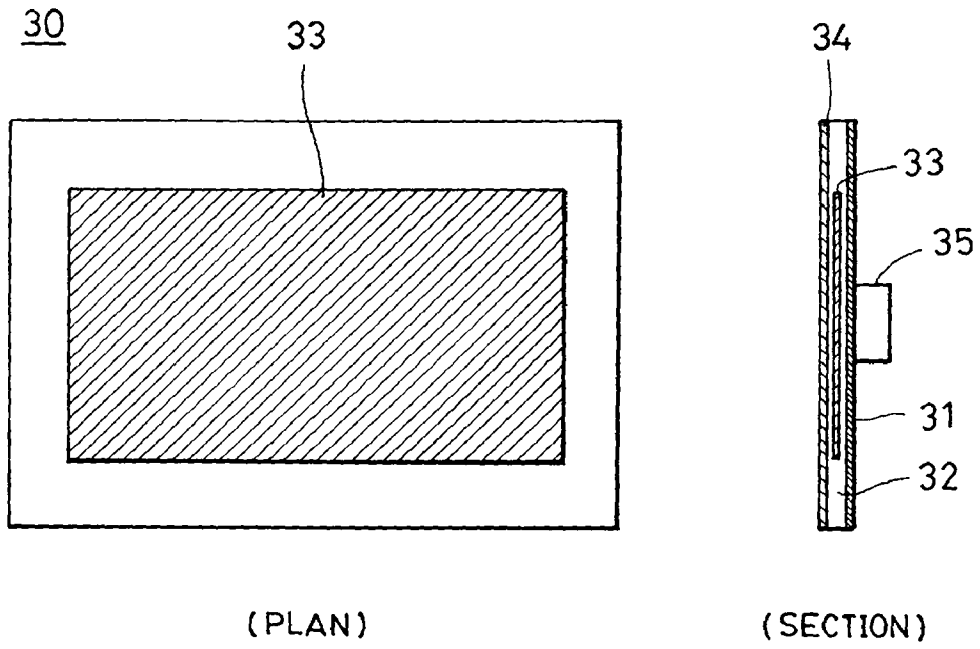

FIG. 4

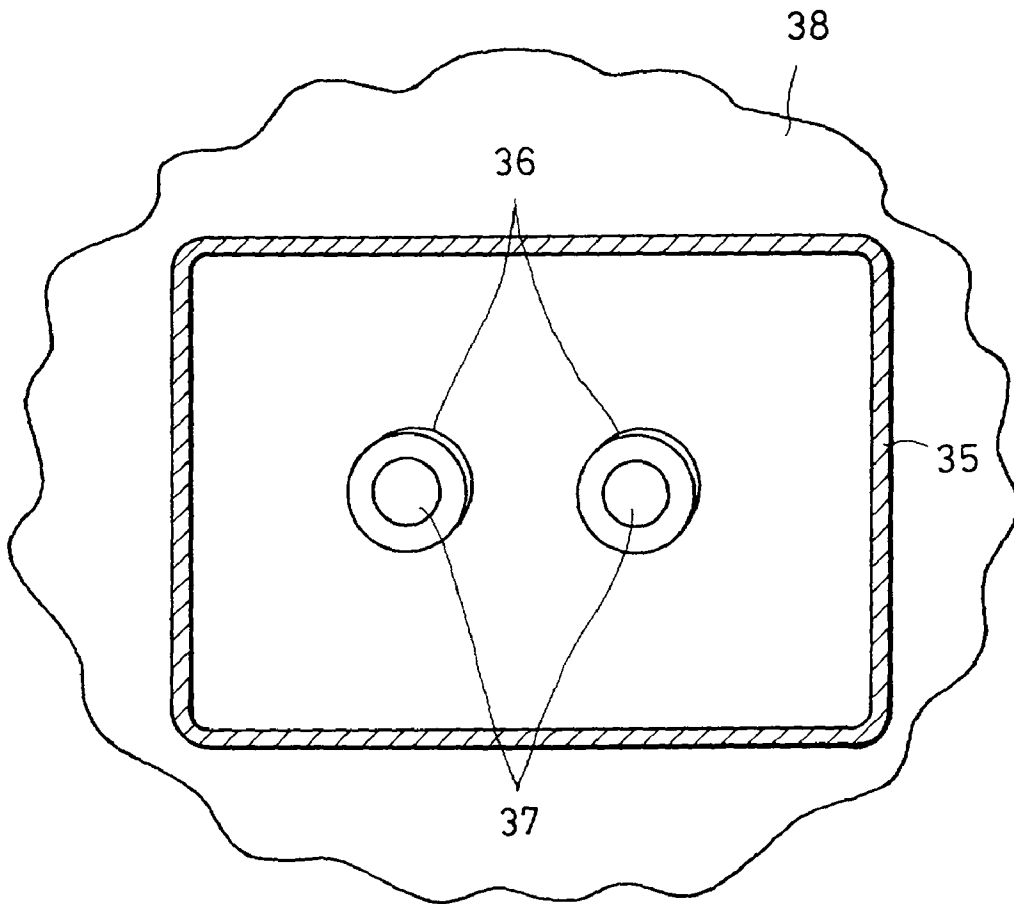

FIG. 5

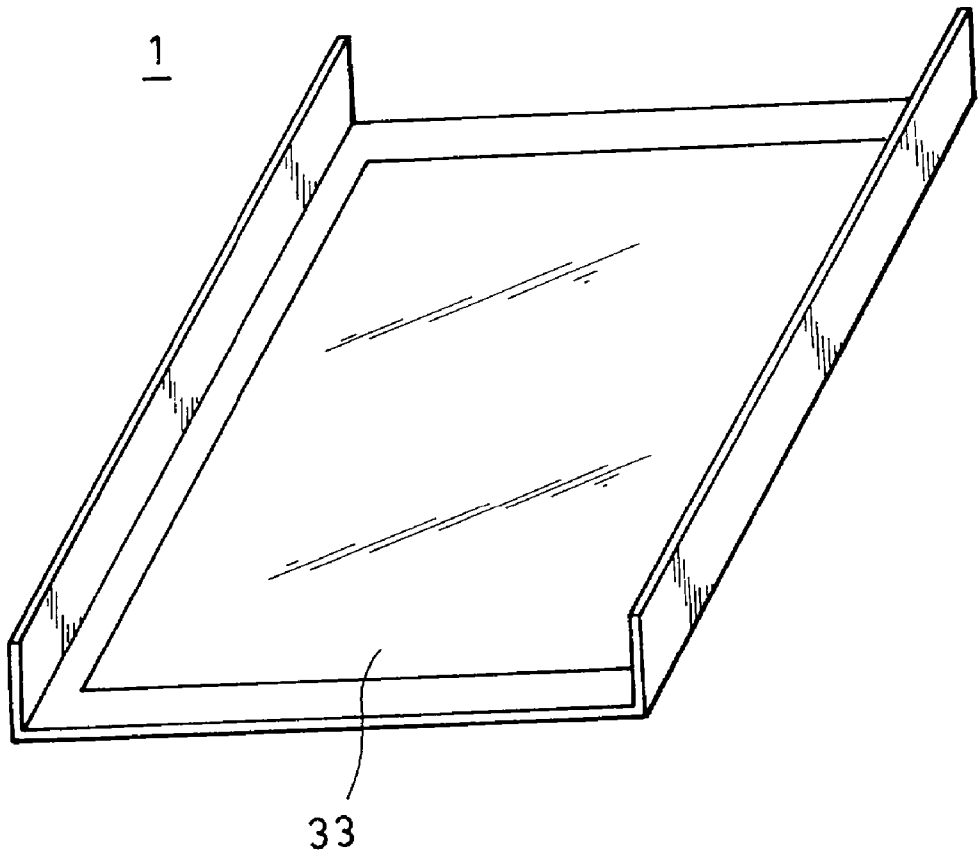

FIG. 6

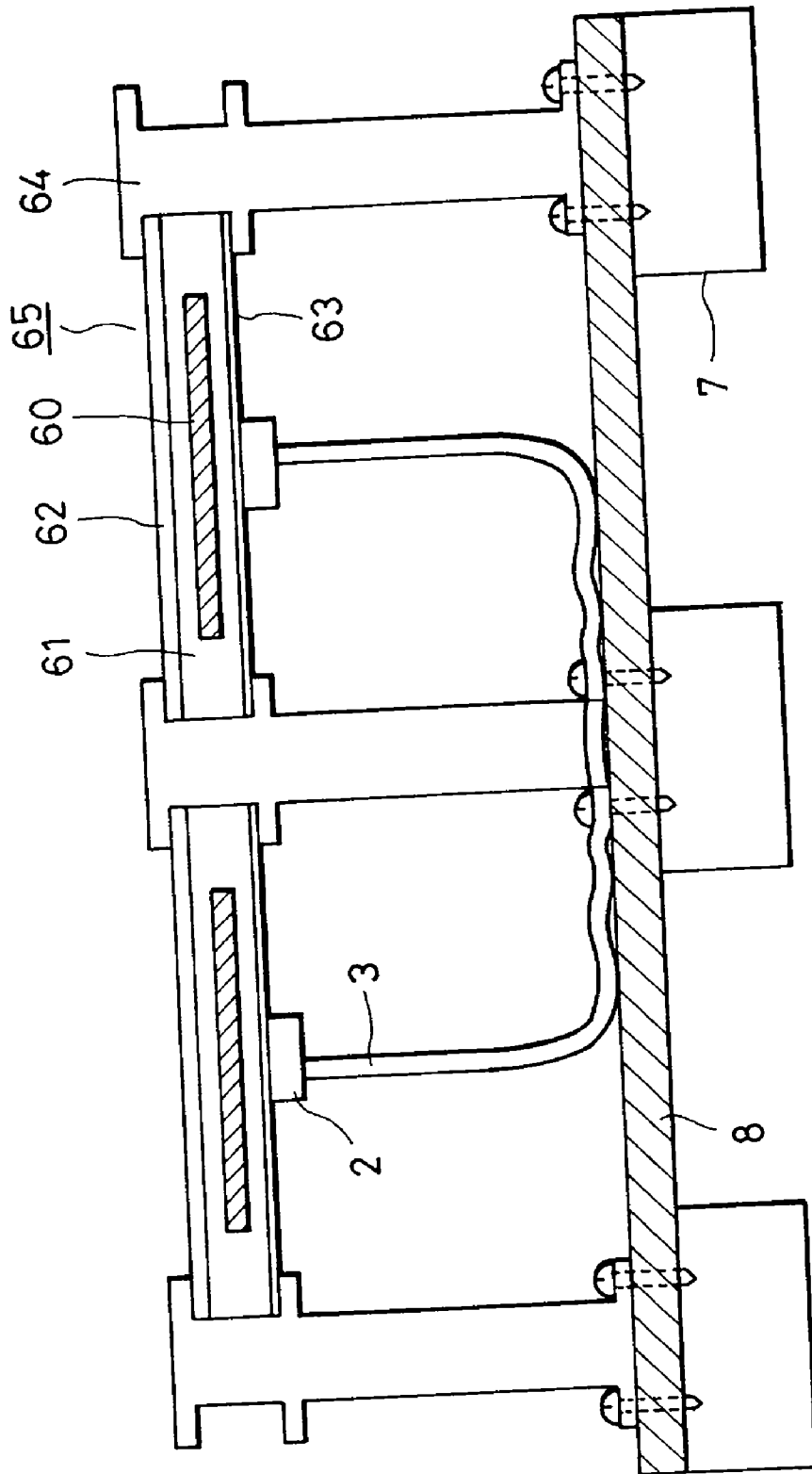

FIG. 7

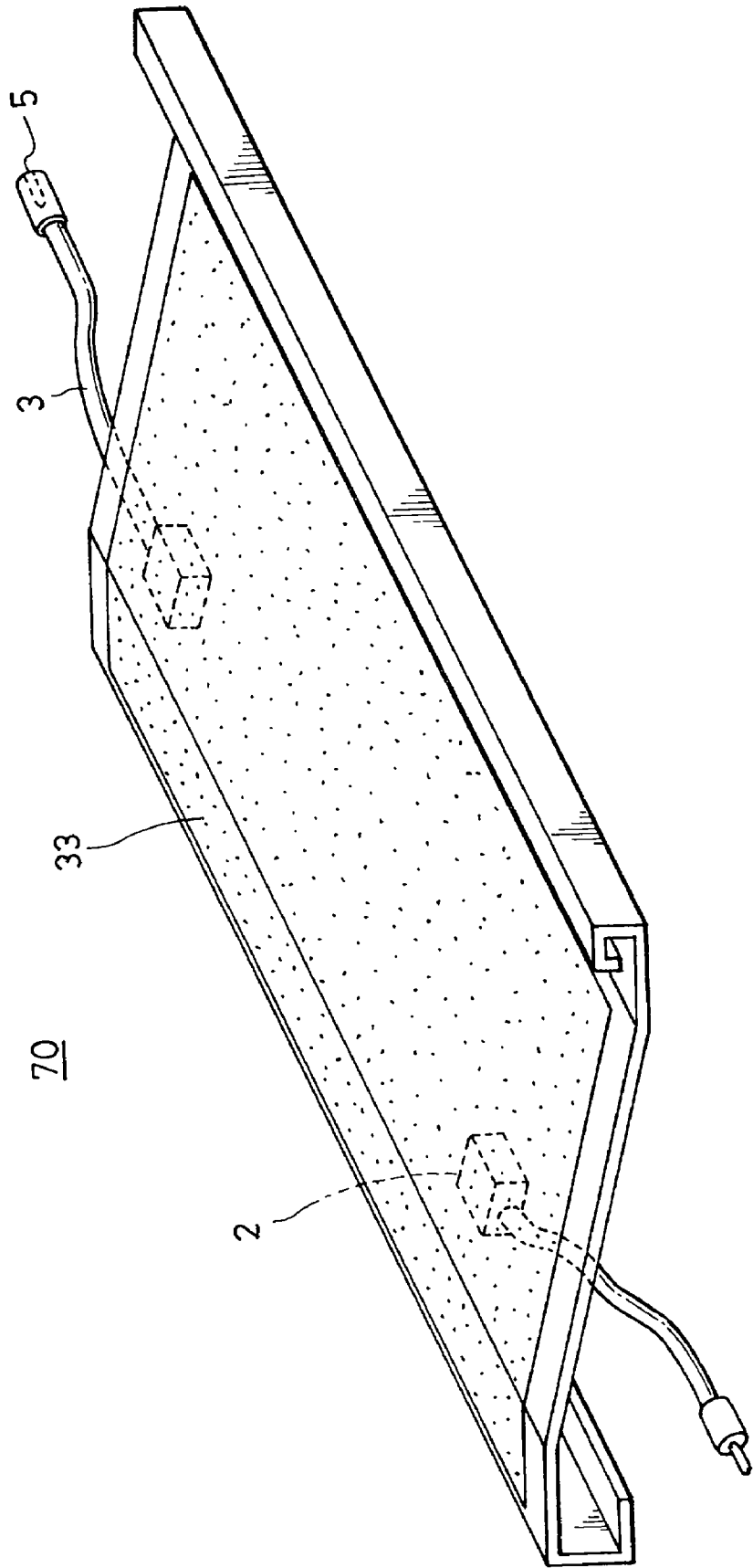
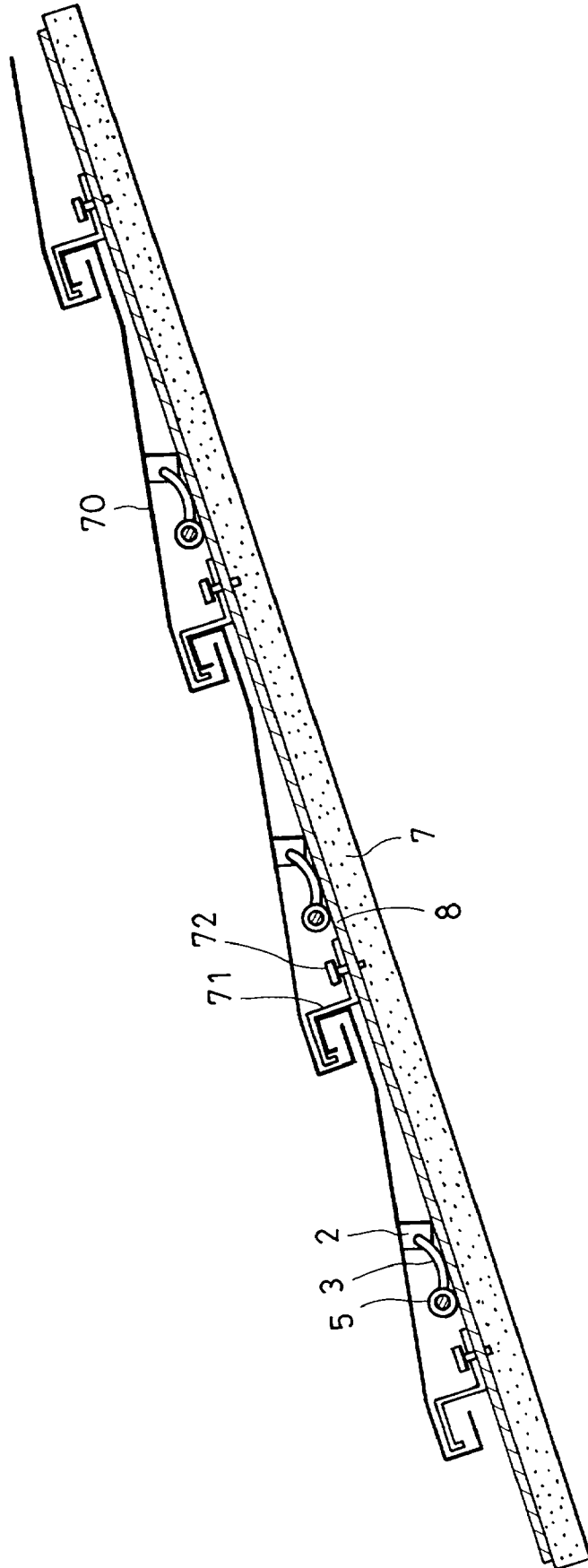

FIG. 8



**BUILDING MATERIAL, CLADDING ASSEMBLY,
METHOD OF INSTALLING BUILDING
MATERIAL, AIR FLOWING APPARATUS AND
GENERATOR**

BACKGROUND OF THE INVENTION

[0001] 1. Field of the Invention

[0002] The present invention relates to a building material, and a cladding assembly, an air flowing apparatus and a generator each comprising the building material, and particularly to a building material comprising solar cell units with excellent long-term reliability which are electrically connected to each other by electrical conductive leads.

[0003] 2. Description of the Related Art

[0004] In recent years, solar cell modules integral with building materials such as a roof, a wall, and the like have been extensively developed and constructed. For example, in Japanese Patent Laid-Open No. 7-211932, roof materials integral with solar cells for batten seam roofing are installed on a backing material such as wood, mortar, cement, or the like through a spacer member. In this case, the adjacent solar cell modules for batten seam roofing are electrically connected by a cord with a connector in the space between the solar cell modules and the backing material.

[0005] In Japanese Patent Laid-Open No. 7-302924, a plurality of roof panels with solar cells for lateral roofing are laid on a roof material, and wiring materials for electrically connecting the roof panels with solar cells are passed through the space between the roof material and the roof panels with solar cells for lateral roofing.

[0006] In the roof panels with solar cells, wiring materials including connectors and connecting cables for electrically connecting the adjacent solar cells are connected in the space between the backing material such as a roof board, and the roof panels with solar cells.

[0007] As described above, where the solar cell modules are laid on the backing material, and the adjacent solar cells are connected by the electrical conductive leads comprising cables and connectors, a method is frequently used in which the adjacent solar cell modules are successively installed on the backing material with the electrical conductive leads of the adjacent solar cell modules arranged in the space between the backing material and the solar cell modules. For example, an eaves-side solar cell module is fixed, and then the electrical conductive lead of a ridge-side solar cell directly above the eaves-side solar cell module is electrically connected in the space between the backing material and the solar cell modules by using, for example, a connector or the like. This work is repeated to successively laying roofing materials on the ridge side.

[0008] However, in the above installation method, the space between the backing material and the solar cell modules is narrow, and connecting works must be carried out on the back sides of the modules, not on the front sides, thereby causing difficulties in working. Also, at low temperatures in winter, the cables and connectors are hardened, and thus the work becomes more difficult.

[0009] Furthermore, since the electrical conductive leads must be connected in the narrow space, the electrical conductive leads are forced to be pulled, or excessive force is

applied to the electrical conductive leads and the connection portions between the electrical conductive leads and the solar cell modules. In some cases, an electrical conductive lead is removed from a solar cell module.

[0010] Therefore, it is thought that the electrical conductive leads of the solar cell modules are lengthened to facilitate the work of connecting the electrical conductive leads of the adjacent solar cell modules.

[0011] In this case, lengthening the electrical conductive lead of each of the solar cell modules inevitably easily causes contact between the electrical conductive leads of the solar cells, such as output leads or the like, and the backing material.

[0012] The inventors found that when the electrical conductive leads of the solar cells modules are brought into contact with the backing material and placed under severe conditions for a long period of time, the performance of the solar cell modules deteriorates in some cases.

[0013] As each of the electrical conductive leads, a conductor coated with a vinyl chloride resin is widely used. As the backing material, an asphalt waterproof sheet, a vinyl chloride sheet, a polyurethane heat insulating material, and a polystyrene heat insulating material are used. Such a conventional system, where the electrical conductive leads are brought into contact with the backing material for a long period of time, some chemical reaction probably takes place between the electrical conductive leads and the backing material to deteriorate the vinyl chloride resin of the electrical conductive leads. This causes deterioration in flexibility of the resin, and thus partial cracks in the vinyl chloride resin. As a result, in outdoor exposure to wind and rain for a long period of time, water enters a terminal box through the cracks of the coating materials of the electrical conductive leads due to the capillary phenomenon, and possibly causes a short circuit in the solar cell modules in a terminal box.

[0014] Furthermore, the water enters the solar cell unit through a terminal hole and reaches the silver paste on the solar cell unit. In the silver paste, silver is ionized by light to cause electromigration, thereby possibly deteriorating the performance of the solar cell unit.

SUMMARY OF THE INVENTION

[0015] The present invention provides a building material with a solar cell comprising a solar cell unit fixed on a substrate, and an electrical conductive lead for leading the output from the solar cell unit to the outside, wherein a jacket material of the electrical conductive lead is composed of at least one selected from the group consisting of polyethylene resins, polyamide resins, vinylidene fluoride resins, chloroprene, ethylene-propylene rubber, silicone resins and fluororesins.

[0016] The present invention also provides a cladding assembly comprising a building material with a solar cell which comprises a solar cell unit fixed on a substrate and which is fixed on a backing material by a fixing member, and an electrical conductive lead arranged between the building material and the backing material to contact the backing material, for leading the output from the solar cell unit to the outside, wherein a jacket material of the electrical conductive lead is composed of at least one selected from the group

consisting of polyethylene resins, polyamide resins, vinylidene fluoride resins, chloroprene, ethylene-propylene rubber, silicone resins and fluoro-resins, and the backing material contains any one of asphalt resins, vinyl chloride resins, polystyrene resins, and polyurethane resins.

[0017] The present invention further provides a method of installing a building material comprising fixing a building material with a solar cell comprising a solar cell unit fixed on a substrate on a backing material by a fixing member, and arranging an electrical conductive lead between the building material and the backing material to bring it into contact with the backing material, for leading the output from the solar cell unit to the outside, wherein a jacket material of the electrical conductive lead is composed of at least one selected from the group consisting of polyethylene resins, polyamide resins, vinylidene fluoride resins, chloroprene, ethylene-propylene rubber, silicone resins and fluoro-resins, and the backing material contains any one selected from the group consisting of asphalt resins, vinyl chloride resins, polystyrene resins, and polyurethane resins.

[0018] The present invention further provides an air flowing apparatus comprising a building material with a solar cell which comprises a solar cell unit fixed on a substrate, and which is fixed on a backing material with a space therebetween so that outside air flows into the space, passes therethrough and is entrapped in a house or discharged to the outdoors, and an electrical conductive lead arranged between the building material and the backing material to contact the backing material, for leading the output from the solar cell unit to the outside, wherein a jacket material of the electrical conductive lead is composed of at least one selected from the group consisting of polyethylene resins, polyamide resins, vinylidene fluoride resins, chloroprene, ethylene-propylene rubber, silicone resins and fluoro-resins, and the backing material contains any one of asphalt resins, vinyl chloride resins, polystyrene resins, and polyurethane resins.

[0019] The present invention further provides a power generator comprising the building material and a power inverter.

[0020] Further objects, features and advantages of the present invention will become apparent from the following description of the preferred embodiments with reference to the attached drawings.

BRIEF DESCRIPTION OF THE DRAWINGS

[0021] FIG. 1 is a schematic sectional view showing an example of a cladding assembly of the present invention;

[0022] FIG. 2 is a schematic sectional view showing an example of an air flowing apparatus of the present invention;

[0023] FIG. 3 is a schematic drawing showing a plan and a section of an example of a solar cell module applied to the present invention;

[0024] FIG. 4 is a schematic plan view showing an example of a terminal outlet of a solar cell module applied to the present invention;

[0025] FIG. 5 is a schematic perspective view showing an example of a building material of the present invention;

[0026] FIG. 6 is a schematic sectional view showing another example of a cladding assembly of the present invention;

[0027] FIG. 7 is a schematic perspective view showing another example of a building material of the present invention; and

[0028] FIG. 8 is a schematic sectional view showing a further example of a cladding assembly of the present invention.

DESCRIPTION OF THE PREFERRED EMBODIMENT

[0029] FIG. 1 shows an example in which a building material with a solar cell is provided on a roof. To the back of a roof panel 1 with a solar cell is mounted a terminal box 2 for outputting power, to which a wiring material 3 is connected for electrical connection with an adjacent roof panel with a solar cell by a connector 5. The roof material 1 is fixed to a spacer member 6 by a fixing member 9 which is covered with a cap 10. The spacer member 6 is fixed on a roof backing material (roof board) 8 fixed on rafters 7 to form a space 11 between the roof material 1 and the roof board 8.

[0030] As described above, when the wiring material 3 is lengthened to some extent for improving wiring workability, the wiring material 3 contacts the roof board 8, as shown in FIG. 1.

[0031] (Electrical Conductive Lead 3)

[0032] A jacket material of an electrical conductive lead for electrically connecting a solar cell unit of the present invention is composed of at least one selected from the group consisting of polyethylene resins, polyamide resins, vinylidene fluoride resins, chloroprene, ethylene-propylene rubber, silicone resins and fluoro-resins.

[0033] Furthermore, the SP value (solubility parameter) of the backing material is preferably different from the SP value of the jacket material of the electrical conductive lead. With the backing material having a SP value different from the SP value of the jacket material of the electrical conductive lead, chemical reaction between the backing material and the jacket material of the electrical conductive lead hardly takes place, thereby further suppressing deterioration of the electrical conductive lead.

[0034] The coating of the electrical conductive lead may be multiple coating as long as at least the outermost coating material comprises one of the above materials.

[0035] Specifically, polyethylene resins which can be used as the jacket material of the electrical conductive lead include high-density polyethylene, low-density polyethylene, fire retardant polyethylene, crosslinked polyethylene, and the like. Examples of wires used as the electrical conductive lead comprising a polyethylene jacket include outdoor polyethylene insulated wires (OE), outdoor crosslinked polyethylene insulated wires (OC), high-tension pull-down crosslinked polyethylene insulated wires (PDC), fireproof wires (FP), heatproof wires (HP), and the like; examples of wires used as the electrical conductive lead comprising a polyamide jacket include heat resisting PVC nylon jacketed wires, vinyl nylon insulated shielding wires, and the like; examples of wires used as the electrical conductive lead comprising a vinylidene fluoride resin jacket include PVF double wires, and the like; examples of wires used as the electrical conductive lead comprising a

chloroprene rubber jacket include cabtyre cables (PNCT, RNCT), and the like; examples of wires used as the electrical conductive lead comprising an ethylene-propylene rubber jacket include high-tension pull-down EP rubber insulated wires (PDP), and the like; examples of wires used as the electrical conductive lead comprising a silicone resin jacket include silicone rubber insulated fiber-glass braided wires (KGB) and the like; examples of wires used as the electrical conductive lead comprising a fluoro-resin jacket include Teflon ETFE wires, Teflon FET wires, PFA insulated wires, and the like.

[0036] (Connector 5)

[0037] In the present invention, connectors can be used for electrically connecting adjacent solar cell units.

[0038] As a material for the connectors, a material having excellent heat resistance, weather resistance, cold resistance and oil resistance is preferably used. From the viewpoint that no chemical reaction with the backing material takes place, as a jacket material of the connector material, a material comprising at least one of polyethylene resins, polyamide resins, vinylidene fluoride resins, chloroprene, ethylene-propylene rubber, silicone resins, and fluoro-resins is preferably used.

[0039] (Roof Backing Material 8)

[0040] The backing material is used for structurally supporting building materials such as a roof, a wall, and the like, and for waterproofing and heat insulation.

[0041] In consideration of durability, cost, general-purpose properties, etc., as material for the backing material, a material containing at least one of asphalt resins, vinyl chloride resins, polystyrene resins, and polyurethane resins is preferably used.

[0042] Specifically, a heat insulating board, a waterproof sheet, and the like can be used. Examples of heat insulating boards include polystyrene foams (board-shaped), hard polyurethane foams (board-shaped), and the like.

[0043] The polystyrene foams (board-shaped) include primary foams (extruded polystyrene foams) formed by continuous extrusion foaming, and secondary foams (beaded polystyrene foams) formed by fusion molding primary foamed beads.

[0044] Each of the hard polyurethane foams (board-shaped) is a heat insulating material obtained by molding, into a board, a foam generally obtained by chemical reaction of polyol, isocyanate and a foaming agent. Since flon gas is used as the foaming agent, the heat insulating materials are characterized by low thermal conductivity and high heat insulation. Examples of such products include a sandwich foam formed in a plate with a predetermined thickness between two facing materials by utilizing the adhesion of urethane resin, and a product cut out from a large block.

[0045] On the roof backing material (roof board) is preferably arranged an under roofing material for improving waterproof performance.

[0046] For example, as the type of the under roofing material, a sheet material, a foamed plastic product, or the like can be used.

[0047] As the sheet material, asphalt roofings, a modified asphalt material, a synthetic resin material, and the like can be used.

[0048] The asphalt roofings include asphalt roofings and asphalt felts. The former comprises special paper referred to as roofing base paper impregnated with straight asphalt, and the surface coated with brown asphalt, and the latter comprises roofing base paper impregnated with straight asphalt.

[0049] The modified asphalt material comprises synthetic rubber of synthetic resin compatible with asphalt, which is mixed with an appropriate amount of asphalt to modify asphalt in order to improve low temperature properties, high temperature properties, nail hole sealing properties, adhesion, durability, etc. Examples of such modified asphalt materials include a material comprising a synthetic fiber nonwoven fabric used as a reinforcing material, and modified asphalt coated on both or one side thereof, a material comprising modified asphalt sandwiched between two fibrous sheets.

[0050] Furthermore, as the synthetic resin material, for example, polyvinyl chloride can be used. Examples of such materials which can be used include a single sheet of polyvinyl chloride, a laminate of polyvinyl chloride and other materials (such as craft paper, a nonwoven fabric, asphalt, coal tar, an asphalt felt, and the like).

[0051] The foamed plastic material is used for obtaining the effects of thermally insulating, preventing dewing, eliminating rain noise, etc.

[0052] (Building Material with Solar Cell)

[0053] As the solar cell used for the building material with a solar cell of the present invention, a silicon semiconductor solar cell such as a single crystal silicon solar cell, a polycrystalline silicon solar cell, an amorphous silicon solar cell, or the like; or a compound solar cell such as a III-V group compound solar cell, a II-VI group compound solar cell, a I-III-VI group compound solar cell, or the like can be used.

[0054] For a thin film solar cell comprising a non-single crystal semiconductor, a solar cell sealed on a substrate with a resin is preferably used. In the use of a metallic steel sheet used for a metallic roof as the substrate, the metallic steel sheet can be bent the same shape as the metallic roof or the like, for example, the shape of a bent sheet or a roll, or a shape for lateral roofing. As the substrate, a flexible resin film can also be used. In this case, like the under roofing material, the substrate can be placed directly on the roof backing material **8** without using the spacer member **6**, and can be protected by glass.

[0055] For the solar cell comprising a single crystal semiconductor, glass is used as the substrate in a light receiving surface, and the solar cell is sealed with a resin on the back of the substrate.

[0056] The solar cell used in the present invention is preferably a non-single crystal silicon solar cell. The non-single crystal silicon solar cell deteriorates by light, but it is recovered by heat annealing. Therefore, particularly, the non-single crystal silicon solar cell is suitable for use in a structure in which the solar cell becomes high temperature, as the roofing material of the present invention. Also, since the non-single crystal silicon solar cell has high structural strength and a bending ability, it has a high degree of selectivity of shapes, and can thus be applied to various shapes of roofs and walls.

[0057] Also, since the solar cell module can also function as a metallic roof, the total cost can be reduced. From the

viewpoint of appearance, the solar cell module can be processed to the same various shapes as conventional metallic roofs, and thus various designs can be made without disorder in an existing building.

[0058] Since the solar cell module uses no glass as a surface protecting material, the weight of the solar cell module can be reduced, and the weight of a roof itself can be reduced due to no need for an intermediate material such as a frame or the like, thereby decreasing damage due to earthquake or the like.

[0059] (Application to Air Flowing Apparatus)

[0060] FIG. 2 is an example in which the building material with the solar cell is applied to an air flowing apparatus for houses. In FIG. 2, the air flow is shown by arrows, i.e., outside air taken in through an eaves portion 12 passes through the space 11 between the roofing material 1 and the roof backing material 8, and is entrapped in a house through a ridge portion 13. At an intermediate position of the air flow passage is provided a fan 14 for flowing air. In the cold season, the air heated in the space 11 is entrapped in the house, and in the hot season, the heated air is discharged to the outside through an exhaust port 18 to improve heat insulation performance. Heat accumulating means may be provided below the floor.

[0061] The electric power generated by the roofing material 1 with the solar cell is introduced in the house through the ridge portion, converted by an inverter 15, and consumed by a load 16 such as an electric light or the like. The inverter 15 may have the function to link with system power 17.

[0062] Embodiment 1

[0063] In this embodiment, amorphous silicon solar cell units were serially connected on a stainless substrate, and a Galvalume steel sheet was provided on the back of the substrate and sealed with a weather resisting resin to form a solar cell module. The module was bent to a shape for batten seam roofing to form a building material with a solar cell.

[0064] Each of the amorphous silicon solar cell units was formed as follows. On a cleaned roll-shaped long stainless substrate having a thickness of 0.1 mm was formed an Al layer containing 1% of Si by sputtering. Next, a n/i/p type amorphous silicon semiconductor layer was formed by a plasma CVD process. Then ITO (indium-tin-oxide) was formed by resistance heating vaporization to form an amorphous silicon solar cell unit. Next, the long solar cell unit formed as described above was punched to a desired size by using a press machine, and the ITO electrode in the periphery of the solar cell unit was removed by etching for repairing a short-circuit. Next, on the ITO was formed, as a collecting grid electrode, silver paste comprising a polyester resin as a binder by screen printing. Then, a tinned copper wire as a collecting electrode of the grid electrode was arranged to cross the grid electrode at right angles. Then, adhesive silver ink was dropped at the intersections with the grid electrode, and dried by heating to connect the grid electrode and the tinned copper wire. At this time, in order to prevent contact between the tinned copper wire and the end surface of the stainless substrate, a polyimide tape was applied below the tinned copper wire.

[0065] The ITO layer/a-Si layer in a portion of the non-generation region of the thus-formed solar cell unit was removed by a grinder to expose the stainless substrate, and a copper foil was welded to the portion by a spot welder to solder the copper foil to the tinned copper wire, followed by serial connection.

[0066] Next, the thus-formed solar cell units were sealed on a metallic plate with a resin. Namely, as shown in FIG. 3, a Galvalume steel sheet 31 having a thickness of 0.8 mm, EVA 32, the serially-connected solar cell units 33, EVA 32 and a fluoro-resin film 34 comprising an unstretched ethylene-tetrafluoroethylene copolymer fluoro-resin film (Aflex, produced by Asahi Glass Co., Ltd.) were laminated in turn, and the EVA was then melted at 150° C. by using a vacuum laminator to form a solar cell module 30 sealed with a weather resisting resin. In the Galvalume steel sheet 31 were previously formed two holes for taking out terminals.

[0067] The adhesive surface of the fluoro-resin film 34 has previously been processed with plasma in order to improve adhesion to the EVA 32. Also the serially connected solar cell units 33 had a size smaller than the Galvalume steel sheet on the back side because the edge of the solar cell module 30 was bent in a later step.

[0068] Next, as shown in FIG. 4, wiring terminals 37 as plus and minus terminals were exposed from the two terminal outlet holes 36 formed in the Galvalume steel sheet 31 on the back of the solar cell module 30. Then a terminal outlet box 35 was mounted by using a silicone resin 38 to cover the two terminal outlet holes 36. Then the wiring material (electrical conductive lead) 3 with the connector 5 was attached to each of the wiring terminals 37.

[0069] Next the edges of the solar cell module 30 were bent upward by using a bending machine to form the roofing material 1 with a solar cell, as shown in FIG. 5.

[0070] Next the roofing material was provided, as shown in FIG. 1. The roof backing material 8 was placed on the rafters 7, and two roofing materials 1 with solar cells of a roll type were installed on the backing material 8 through the C-shaped spacer steel materials 6 to form a roof.

[0071] An accelerated weathering test was carried out with varying materials of the electrical conductive lead 3 and the backing material 8 to measure the output retention of the solar cells.

[0072] Specifically, as the coating material of the electrical conductive lead 3, a conventional vinyl chloride resin and a polyethylene resin, a polyamide resin, a vinylidene fluoride resin, butyl rubber, chloroprene, ethylene-propylene rubber, a silicone resin, and a fluoro-resin of the present invention were used. As the backing material 8, an asphalt waterproof sheet, a vinyl chloride sheet, a polyurethane heat insulating material, a polystyrene heat insulating material, a cemented excelsior board, and a water-resistant plywood were used in the test.

[0073] A 600-V crosslinked polyethylene insulated vinyl sheath power cable (600-V CV) having a conductor sectional area of 2 mm² was used as the electrical conductive lead comprising a vinyl chloride resin as the coating material; a single outdoor crosslinked polyethylene insulated electric wire (OC) having a conductor outer diameter of 5 mm was used as the electrical conductive lead comprising a polyethylene resin jacket; a heatproof PVC nylon jacket wire having a conductor outer diameter of 1.53 mm was used as the electrical conductive lead comprising a polyamide jacket; a polyvinylidene fluoride wire (PVF) with a rated voltage of 600 V having a conductor outer diameter of 1.5 mm was used as the electrical conductive lead comprising a vinylidene fluoride resin jacket; a cable (2PNCT) having a conductor sectional area of 2 mm² was used as the electrical conductive lead comprising a chloroprene coating material; a high-tension pull-down EP rubber

insulated wire (PDP) having a conductor outer diameter of 2 mm was used as the electrical conductive lead comprising an ethylene-propylene rubber coating; a silicone rubber insulated fiber-glass braided wire (KGB) having a conductor sectional area of 2 mm² was used as the electrical conductive lead comprising a silicone resin coating; a Teflon FEP wire having a conductor sectional area of 2 mm² was used as the electrical conductive lead comprising a fluoro-resin coating.

[0074] For the backing material 8, "Mitsuboshi Roofing" produced by Tajima Roofing Co., Ltd. was used as an asphalt waterproof sheet; "Hytonton" produced by Matsushita Electric Works, Ltd., a vinyl chloride sheet; "Achilles Board" produced by Achilles Co., Ltd., a polyurethane heat insulation; and "Kanelight Foam" produced by Kaneka Corporation, a polystyrene heat insulation.

[0075] The accelerated test was carried out as described below. First, in order to securely achieve contact between the electrical conductive lead 3 and the backing material 8, a weight was placed on the electrical conductive lead 3. In this state, the accelerated weathering test was carried out on the assumption that the solar cell module was exposed to sunlight, wind and rain for a long period of time outdoors, e.g., on a roof.

[0076] In order to stabilize the performance of the solar cells, the building materials with solar cells installed on the backing material were exposed under the light condition of 1 SUN for 1000 hours to accelerate initial deterioration of the solar cells. At the same time, the initial output of the solar cell module was measured. Then, the building materials with solar cells were placed in a high-temperature-high-humidity chamber of a temperature of 85° C. and a humidity of 85% for 500 hours. After the weight was removed, the building materials 1 with solar cells were removed from the spacer steel material 6. The electrical conductive lead 3 was wound 10000 turns on a cylinder having a diameter of 20 mm, and placed in a 1-SUN sunshine weatherometer for 3000 hours. Then, the output of the building material 1 with the solar cell was measured.

[0077] The output retention of the solar cell module after the accelerated weathering test relative to the output of the solar cell module before the accelerated weathering test was considered as the solar cell output retention. The results are shown in Table 1.

TABLE 1

(Solar cell output retention after accelerated weathering test)						
Backing material	Asphalt water-poor sheet	Vinyl chloride sheet	Poly-urethane heat insulation	Poly-styrene heat insulation	Cemented excelsior board	Water-proof plywood
	Coating material of connecting wire Vinyl chloride resin					
Solar cell output retention (%)	5%	3%	2%	7%	98%	97%
	Coating material of connecting wire Polyethylene resin					
Solar cell output retention (%)	101%	98%	98%	97%	99%	99%

TABLE 1-continued

(Solar cell output retention after accelerated weathering test)						
Backing material	Asphalt water-poor sheet	Vinyl chloride sheet	Poly-urethane heat insulation	Poly-styrene heat insulation	Cemented excelsior board	Water-proof plywood
	Coating material of connecting wire Polyamide resin					
Solar cell output retention (%)	103%	98%	95%	98%	98%	102%
	Coating material of connecting wire Vinylidene fouride resin					
Solar cell output retention (%)	97%	96%	96%	98%	104%	97%
	Coating material of connecting wire Chloroprene					
Solar cell output retention (%)	101%	98%	99%	99%	97%	94%
	Coating material of connecting wire Ethylene-propylene rubber					
Solar cell output retention (%)	99%	93%	93%	98%	93%	98%
	Coating material of connecting wire Silicone resin					
Solar cell output retention (%)	104%	101%	98%	99%	98%	99%
	Coating material of connecting wire Fluoro-resin					
Solar cell output retention (%)	96%	100%	101%	96%	98%	99%

[0078] In the system using a vinyl chloride resin as the coating material for the electrical conductive lead (connecting wire) and each of an asphalt waterproof sheet, a vinyl chloride sheet, a polyurethane heat insulation, and a polystyrene heat insulation as the backing material, the output from the solar cell module was hardly obtained after the accelerated weathering test.

[0079] On the other hand, in the system using a vinyl chloride resin as the coating material for the electrical conductive lead, and each of a cemented excelsior board and a waterproof plywood as the backing material, deterioration in output of the solar cell module was hardly observed after the accelerated weathering test.

[0080] On the other hand, in the system using each of a polyethylene resin, a polyamide resin, a vinylidene fluoride resin, butyl rubber, chloroprene rubber, ethylene-propylene rubber, a silicone resin and a fluororesin as the coating material for the electrical conductive lead 3, no deterioration in output of the solar cell module was observed after the accelerated weathering test regardless of the type of the backing material 8 used.

[0081] As a result of analysis of the solar cell module in which no output was obtained after the accelerated test, the portion of the coating material of the electrical conductive lead of the solar cell module which contacted the backing material was greatly hardened, and the electrical conductive lead was partially cracked.

[0082] Therefore, as a result of examination of the resistance between the plus-side outlet portion and the minus-side outlet portion, it was found that the electrical conductive leads in the plus-side outlet portion and the minus-side outlet portion are short-circuited.

[0083] Also as a result of observation of the inside of the terminal outlet box 2 of the roofing material, the terminal outlet portion of the solar cell module was wetted. This indicated that the plus and minus terminal wiring materials 37 are short-circuited.

[0084] Next, the portion of the system in which no output was obtained after the accelerated test due to the electric short circuit caused by wetting in the terminal box 2 of the roofing material 1 was sufficiently dried by a dryer, and then the output of the solar cell was measured. The results are shown in Table 2.

TABLE 2

Backing material	Coating material of connecting wire			
	Asphalt water-poor sheet	Vinyl chloride sheet	Poly-urethane heat insulation	Poly-styrene heat insulation
Solar cell output retention (%)	78%	83%	80%	85%

[0085] As shown in Table 2, in the solar cell module in which the short-circuited portion was dried by a dryer, the output retention was recovered to only about 80%.

[0086] (Embodiment 2)

[0087] Although, in Embodiment 1, the amorphous silicon solar cell was used as a solar cell unit, in this embodiment, a glass-sealed solar cell module using a crystalline solar cell was formed, and two solar cell modules were installed on various backing materials with a space therebetween in the same manner as Embodiment 1.

[0088] This embodiment will be described in detail below with reference to FIG. 6. A crystalline silicon solar cell was used as a solar cell unit 60, and a grid electrode was mounted thereto. Then, two crystalline silicon solar cell units were serially connected. The serially connected crystalline silicon solar cell units 60 were arranged between a glass surfacing material 62 and a back sealing material 63 com-

prising moisture-resistant fluororesin with an aluminum foil sandwiched therein, and sealed with EVA used as a filler 61 to form a solar cell module 65.

[0089] In the terminal outlet portion of the solar cell module 65 were formed two terminal outlet holes, and were provided a terminal box 2 and an electrical conductive lead 3 in the same manner as Embodiment 1.

[0090] The two solar cell modules 65 were set in a frame 64, and the frame 64 was mounted to a backing material 8 and supporting materials 7.

[0091] In this embodiment, as in Embodiment 1, a vinyl chloride resin, a polyethylene resin, a polyamide resin, a vinylidene fluoride resin, butyl rubber, chloroprene rubber, ethylene-propylene rubber, and a silicone resin, a fluororesin were used as the coating material for the electrical conductive lead (connecting wire), and an asphalt waterproof sheet, a vinyl chloride sheet, a polyurethane heat insulator, a polystyrene heat insulator, a cemented excelsior board, and a waterproof plywood were used in the test.

[0092] In the system using a conventional vinyl chloride resin as the coating material for the electrical conductive lead and each of an asphalt waterproof sheet, a vinyl chloride sheet, a polyurethane insulating material and a polystyrene insulating material as the backing material, as in Embodiment 1, all solar cell modules were short-circuited after the accelerated test, and no output was obtained. As a result of analysis of a solar cell module in which no output was obtained after the accelerated test, the coating material of the electrical conductive lead of the solar cell module was greatly hardened, and thus the electrical conductive lead was partially cracked. As a result of observation of the inside of the terminal outlet box of the solar cell module, the terminal outlet portion of the solar cell module was wetted, as in Embodiment 1. It was thus confirmed that the plus and minus terminal wiring materials respectively exposed from the terminal outlet holes were electrically short-circuited.

[0093] On the other hand, in the system using each of a polyethylene resin, a polyamide resin, a vinylidene fluoride resin, chloroprene rubber, ethylene-propylene rubber, a silicone resin and a fluororesin as the coating material for the electrical conductive lead, as in Embodiment 1, no deterioration was observed in output of the solar cell module after the accelerated test regardless of the type of the backing material used.

[0094] (Embodiment 3)

[0095] An accelerated test was carried out by the same method as Embodiment 2 except that a polycrystalline silicon solar cell unit was used as a solar cell unit in place of the crystalline silicon solar cell used in Embodiment 1. The same results as Embodiment 2 were obtained.

[0096] (Embodiment 4)

[0097] The solar cell module shown in FIG. 3 was formed by the same method as Embodiment 1, and bent to the shape of a so-called lateral roofing material as shown in FIG. 7 to form a roofing material 70 with a solar cell. In order to provide this roofing material 70, the roofing material 70 positioned on the eaves side is first fixed on the roof backing material 8 by a clip 71 and a nail 72. The roof backing material 8 comprises an asphalt waterproof sheet placed on a batten fixed on rafters 7. The building materials 70 with solar cells adjacent in the lateral direction are electrically

connected by electrical conductive leads **3** and connectors **5** between the roofing materials **70** and the roof backing material **8**. After such exertion, the same accelerated test as Embodiment 1 was carried out to obtain the same results as Embodiment 1.

[0098] As described above, in a building material with a solar cell of the present invention, electrical conductive leads for electrically connecting solar cells can be laid to contact the backing material, and the electrical conductive lead of a solar cell unit can thus be lengthened. Therefore, in laying the solar cell units on the backing material, excessive force is not applied to the connection between the solar cell body and the electrical conductive lead, thereby improving laying workability of the solar cell units.

[0099] Also the building material with a solar cell of the present invention causes no cracking in the electrical conductive lead of the solar cell unit even if the backing material and the electrical conductive lead of the solar cell unit contact each other for a long period of time, and thus has the effect of stabilizing the performance of the solar cell unit.

[0100] Furthermore, in the building material with a solar cell of the present invention, solar cell modules can be laid directly on a waterproof sheet such as an asphalt roofing, and thus the electrical conductive leads can be passed even in a narrow space.

[0101] While the present invention has been described with reference to what are presently considered to be the preferred embodiments, it is to be understood that the invention is not limited to the disclosed embodiments. On the contrary, the invention is intended to cover various modifications and equivalent arrangements included within the spirit and scope of the appended claims. The scope of the following claims is to be accorded the broadest interpretation so as to encompass all such modifications and equivalent structures and functions.

What is claimed is:

1. A building material with a solar cell comprising a solar cell unit fixed to a substrate, and an electrical conductive lead for leading output from the solar cell unit to the outside, wherein the electrical conductive lead is composed of at least one selected from the group consisting of polyethylene resins, polyamide resins, vinylidene fluoride resins, chloroprene rubber, ethylene-propylene rubber, silicone resins, and fluoro-resins.

2. A building material according to claim 1, wherein the substrate is composed of at least one selected from the group consisting of metals, resins and glass.

3. A building material according to claim 1, further comprising a connector provided at the end of the electrical conductive lead and composed of at least one selected from the group consisting of polyethylene resins, polyamide resins, vinylidene fluoride resins, chloroprene rubber, ethylene-propylene rubber, silicone resins, and fluoro-resins.

4. A cladding assembly comprising:

a plurality of building materials with solar cells each of which comprises a solar cell unit fixed to a substrate, and is fixed on a backing material by a fixing member; and

electrical conductive leads arranged between the building materials and the backing material to contact the backing material, for leading output from the solar cell units to the outside;

wherein a jacket material of each of the electrical conductive leads is composed of at least one selected from the group consisting of polyethylene resins, polyamide resins, vinylidene fluoride resins, chloroprene rubber, ethylene-propylene rubber, silicone resins, and fluoro-resins; and the backing material contains any one of asphalt resins, vinyl chloride resins, polystyrene resins, and polyurethane resins.

5. A cladding assembly according to claim 4, wherein the substrate is composed of at least one selected from the group consisting of metals, resins and glass.

6. A cladding assembly according to claim 4, further comprising a connector provided at the end of each of the electrical conductive leads and composed of at least one selected from the group consisting of polyethylene resins, polyamide resins, vinylidene fluoride resins, chloroprene rubber, ethylene-propylene rubber, silicone resins, and fluoro-resins.

7. A cladding assembly according to claim 4, further comprising a spacer member provided between the building materials and the backing material.

8. A cladding assembly according to claim 4, wherein the plurality of building materials are arranged on the backing material so that the adjacent building materials are electrically connected by the electrical conductive leads.

9. A method of installing a building material:

fixing a plurality of building materials with solar cells each comprising a solar cell unit fixed to a substrate on a backing material by a fixing member; and

arranging an electrical conductive lead between the corresponding building material and the backing material to bring the electrical conductive lead into contact with the backing material, for leading output from each of the solar cell units to the outside;

wherein a jacket material of the electrical conductive lead is composed of at least one selected from the group consisting of polyethylene resins, polyamide resins, vinylidene fluoride resins, chloroprene rubber, ethylene-propylene rubber, silicone resins, and fluoro-resins, and the backing material contains any one of asphalt resins, vinyl chloride resins, polystyrene resins, and polyurethane resins.

10. A method of installing a building material according to claim 9, further comprising providing a spacer member between the building materials and the backing material.

11. A method of installing a building material according to claim 9, further comprising arranging the plurality of the building materials on the backing material, and electrically connecting the electrical conductive leads of the adjacent building materials.

12. An air flowing apparatus comprising:

a building material with a solar cell which comprises a solar cell unit fixed to a substrate and which is fixed to a backing material with a space therebetween so that outside air flows in the space, passes through the space and is entrapped in a house or discharged to the outdoors; and

an electrical conductive lead arranged between the building material and the backing material to contact the backing material, for leading output from the solar cell unit to the outside;

wherein a jacket material of the electrical conductive lead is composed of at least one selected from the group consisting of polyethylene resins, polyamide resins, vinylidene fluoride resins, chloroprene rubber, ethyl-

ene-propylene rubber, silicone resins, and fluoro-resins, and the backing material contains any one of asphalt resins, vinyl chloride resins, polystyrene resins, and polyurethane resins.

13. A power generator comprising a building material according to claim 1, and a power inverter.

* * * * *