

April 17, 1962

A. JACKSON ETAL

3,030,602

BRACKET REINFORCEMENT FOR LOCKING CONNECTORS

Filed Jan. 13, 1959

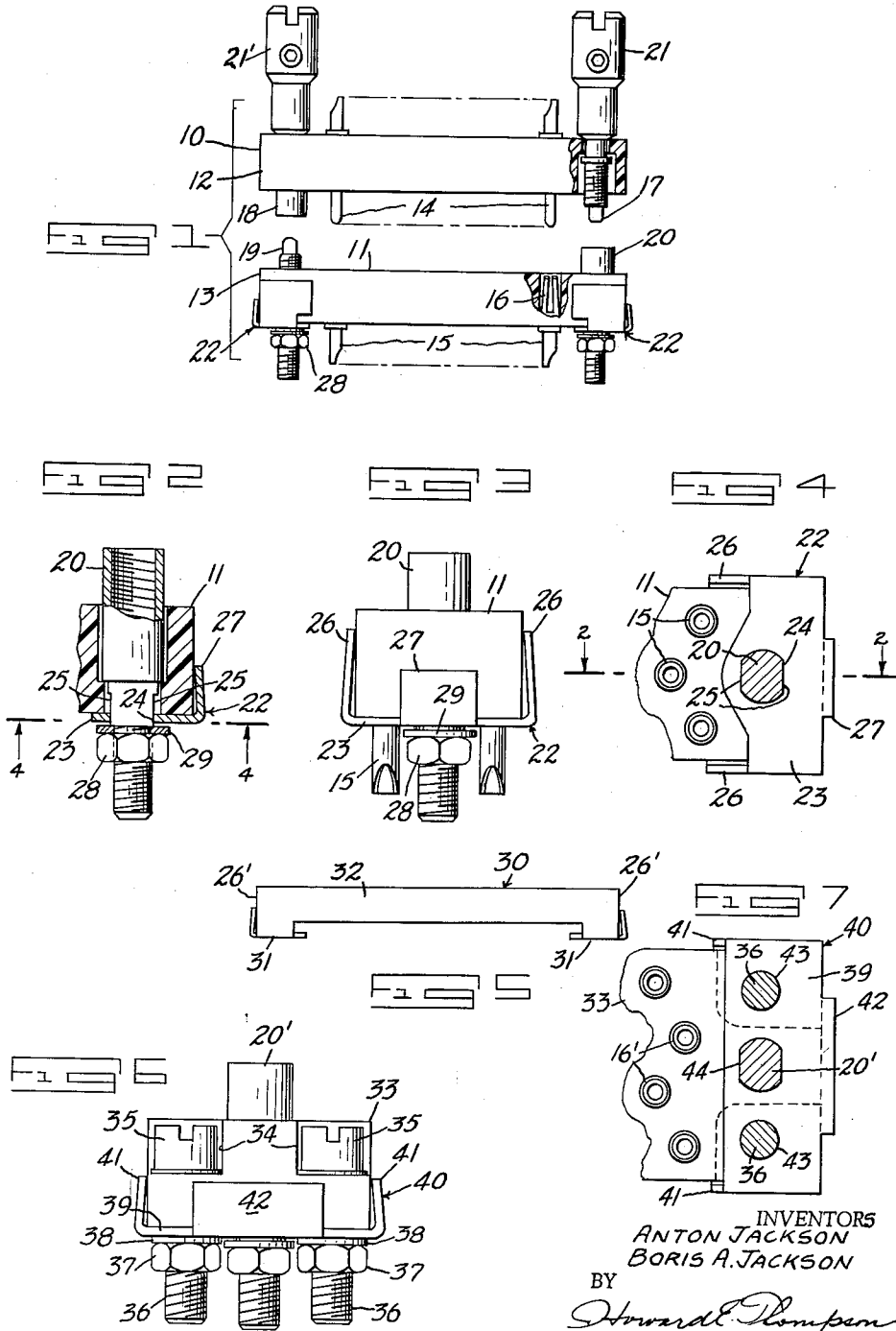

INVENTORS
ANTON JACKSON
BORIS A. JACKSON

BY
Howard E. Thompson

ATTORNEY

1

2

3,030,602

BRACKET REINFORCEMENT FOR LOCKING CONNECTORS

Anton Jackson, Truedale Lake Drive, South Salem, N.Y.,
and Boris A. Jackson, 30 La Farge Lane, Manhasset, N.Y.

Filed Jan. 13, 1959, Ser. No. 786,520
2 Claims. (Cl. 339-92)

This invention relates to electrical connectors employing male and female contacts on two connector bodies, the bodies having means for coupling and locking the connectors together with the contacts in engagement. More particularly, the invention deals with connectors of the character described, wherein reinforcements, in the form of brackets, are provided at ends of the connectors, in conjunction with which the coupling pins and sockets are mounted to take up the stress or strain in the operation of securing the connectors together and to prevent breakage of the molded connected bodies.

Still more particularly, the invention deals with brackets of the character described, comprising bottom plates, in which the coupling pin and sockets are keyed, the plates having two side and one end wall engaging side and end walls of the connector body.

The novel features of the invention will be best understood from the following description, when taken together with the accompanying drawing, in which certain embodiments of the invention are disclosed and, in which, the separate parts are designated by suitable reference characters in each of the views, and in which:

FIG. 1 is a bracketed view, diagrammatically illustrating two pin and socket connectors, with parts of the construction broken away and in section and illustrating reinforcing brackets arranged upon one of the connector bodies.

FIG. 2 is an enlarged sectional view of one end portion of one of the connectors shown in FIG. 1, with part of the construction shown in elevation and broken away, the section being on the line 2-2 of FIG. 4.

FIG. 3 is an end view of the structure shown in FIG. 2.

FIG. 4 is a section on the line 4-4 of FIG. 2.

FIG. 5 is a side view of a modified form of bracket construction detached, wherein two brackets are integrally joined in their side plates.

FIG. 6 is a view, similar to FIG. 3, showing an enlarged and modified type of connector and bracket structure; and

FIG. 7 is a view, similar to FIG. 4 of the structure shown in FIG. 6.

Our improved locking connector deals with devices of this type and kind as generally illustrated in our prior Patent Number 2,845,604, granted July 29, 1958, and, in FIG. 1 of the drawing for illustrative purposes, we have diagrammatically shown a male connector unit at 10 and a female connector unit at 11. The units 10 and 11 comprise molded connector bodies 12 and 13, respectively, preferably formed of plastics, to provide the insulating properties. The body 12 is adapted to support a plurality of male contact pins, part of which are indicated at 14; whereas, the body 13 supports a corresponding number of female sockets, part of which are indicated at 15, the spring end of one socket being indicated at 16 to illustrate establishment of electrical connection with one of the pins 14, when the connectors are coupled together by the alignment and coupling pins and sockets 17 and 18 on the connector 10 and 19 and 20 on the connector 11.

The pin and socket 17 and 18 of the connector 10 include screwdriver heads 21 and 21', respectively, for rotating 17 and 18 in establishing coupling engagement with 20 and 19, respectively, of the connector 11. The pins and sockets 17 and 18; 19 and 20 have a free mounting

in the respective connectors 10 and 11, as is clearly indicated by the sectional portion of the connector 10 in FIG. 1 and the sectional showing of FIG. 2. This is to establish free movement of the pins and sockets in assuring positive alignment and non-jamming coupling and uncoupling between the two connectors.

To simplify the present illustration, we have shown bracket-type reinforcing members 22 mounted on the ends of the connector 11, it being understood that, if desired, similar type of members can be mounted on the connector 10. The members 22 comprise a bottom plate 23, having a key-type of aperture 24 centrally thereof, as clearly noted in FIG. 4 of the drawing, to receive the flattened shanks 25 of the pin and socket members 19 and 20, the sides of the socket member 20 only being shown by way of illustration. This construction retains the pin and sockets 19 and 20 against rotation in the connector 11, while the pin and socket 17 and 18 are free to rotate in the connector 10. The members 22 also include side plates 26 which preferably bear upon the sides of the connector 11, as clearly noted in FIG. 3 of the drawing. The members also include an end plate 27 which bears upon the end walls of the connector 11, as indicated, for example, in FIG. 2 of the drawing.

The pin and socket 19 and 20 have threaded ends, upon which are mounted nuts 28, which bear upon washers 29, seating upon the portions of the connectors having the flattened sides 25 in such manner as to provide slight clearance for axial movement of the pin and socket 19 and 20 in the connector 11. In this connection, it will be noted, from a consideration of FIG. 1 of the drawing, that the coupling of the heads 21 with the pin and socket 18 is such as to provide similar clearance for axial movement.

The contacts 14 and 15 are more or less of conventional construction and include the means projecting beyond surfaces of the connectors 10 and 11 for attachment of circuit wires therewith, but no detailed description of the contacts is deemed to be necessary.

In FIG. 5 of the drawing is shown a slight modification, wherein a unitary reinforcing member 30 is employed which includes bracket ends, as at 31, which would be substantially identical with the brackets 22, the only difference being that side plates 26' of the bracket ends 31 are integrally joined in a plate portion 32, so that the bracket ends 31 will have a definite spacing one with respect to the other. A structure of this type and kind will be more costly than utilizing the brackets, as shown at 22, but assemblage with the connector is simplified. As each bracket end 31 is of the same general structure as the brackets 22, no further description is deemed to be necessary.

In FIGS. 6 and 7 of the drawing, we have shown a modified form of connector 33 which differs from the connector 11 in being of greater width to accommodate a greater number of contacts, indicated in part at 16' in FIG. 7 of the drawing. The connector 33 is modified in providing recessed ends, as at 34, for reception of the heads 35 of mounting screws 36 for mounting the connector in connection with suitable supports.

Arranged on the screws 36 are nuts 37 for drawing washers 38 into firm engagement with the bottom plate 39 of a bracket 40 which is generally similar to the bracket 22; in other words, the bracket 40 includes side plates 41, similar to the side plates 26, an end plate 42, similar to the end plate 27 for engagement with the side and end wall of the connector 33.

At 20' is indicated a coupling socket, identical with the socket 20, and it will be understood that the opposed end of the connector 33 will employ a coupling pin, similar to the pin 19, and also the two screws, as at 36.

With the structure shown in FIGS. 6 and 7, it will be

3

apparent that the bracket 40, or the bottom plate 39 thereof, will have apertures, as at 43, for reception of the screws 36, as well as a key aperture 44, similar to the aperture 24, for reception of the coupling socket 20'.

Having fully described our invention, what we claim as new and desire to secure by Letters Patent is:

1. In connectors of the class described, an elongated body of plastic material having pin and socket alinement and couplings at end portions thereof, means comprising bracket members arranged on end portions of the connector body for reinforcing the connector body where the pin and socket alinement and couplings are coupled therewith, said brackets comprising a bottom plate and integral side and end plates disposed on side and end walls of each bracket being inwardly contracted to bear on the end and sides of the connector body, and the bottom plate of said brackets having apertures in which said pin and socket alinement couplings are snugly arranged.

2. In connectors of the class described, an elongated body of plastic material having pin and socket alinement and couplings at end portions thereof, means comprising bracket members arranged on end portions of the connector body for reinforcing the connector body where the

4

pin and socket alinement and couplings are coupled therewith, said brackets comprising a bottom plate and integral side and end plates disposed on side and end walls of the connector body, said end plate and side plates of each bracket being inwardly contracted to bear on the end and sides of the connector body, the bottom plate of said brackets having apertures in which said pin and socket alinement couplings are snugly arranged, a pair of screws mounted in each end portion of the connector body, and the bottom plate of said brackets having apertures receiving said screws in positive mounting of the brackets on end portions of the connector body.

References Cited in the file of this patent

UNITED STATES PATENTS

2,089,844	Anderson	Aug. 10, 1937
2,760,174	Burt et al.	Aug. 21, 1956
2,761,108	Jackson et al.	Aug. 28, 1956
2,788,386	McCarty	Apr. 9, 1957
2,845,603	Jackson et al.	July 29, 1958
2,845,604	Jackson et al.	July 29, 1958
2,888,660	Fox	May 26, 1959
2,902,665	D'Amico	Sept. 1, 1959