

July 17, 1962

R. L. MANNING

3,044,673

KNIFE SHEATH

Filed July 10, 1959

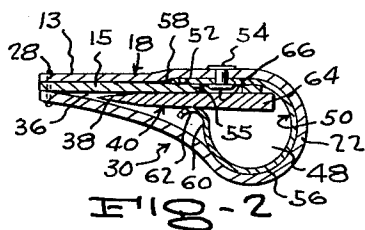
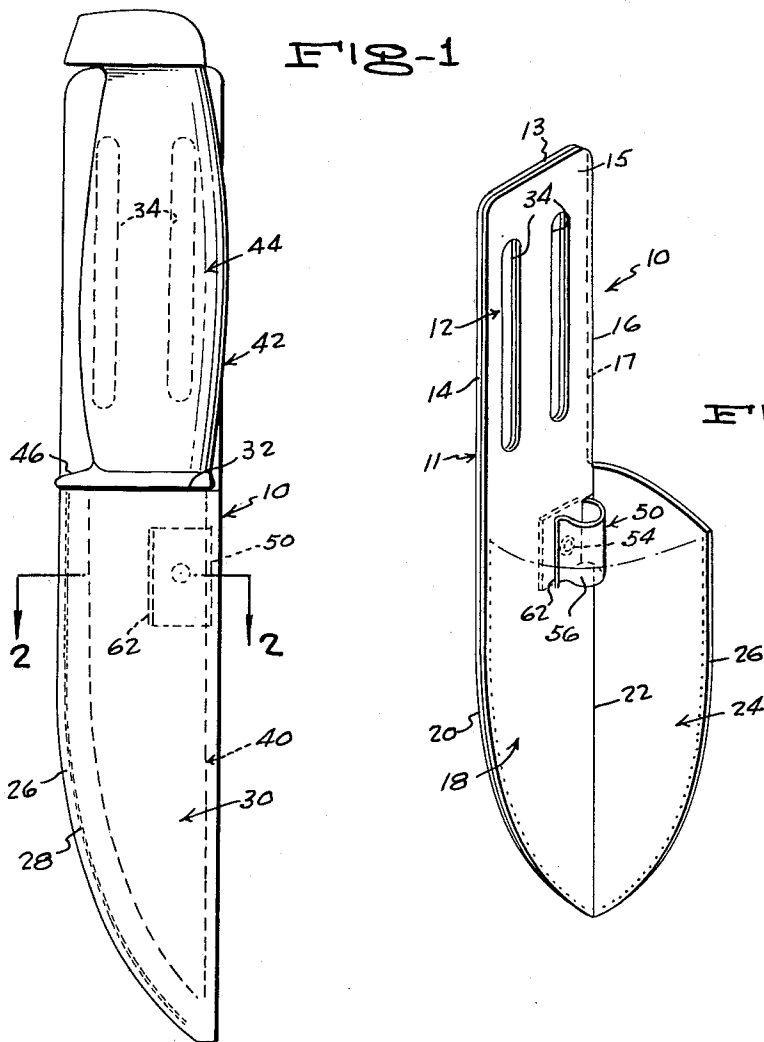

INVENTOR.

RICHARD L. MANNING

BY

*McMorrow, Berman & Davidson*  
ATTORNEYS

1

3,044,673

**KNIFE SHEATH**

Richard L. Manning, Whittier, Calif.  
(679 Center St., Costa Mesa, Calif.)

Filed July 10, 1959, Ser. No. 826,204

4 Claims. (Cl. 224-2)

This invention relates to an improved knife sheath of the type having knife blade engaging means for releasably retaining a knife in the sheath.

The primary object of the invention is to provide a more efficient and practical sheath of the kind indicated which has a spring clip, serving as the knife blade retaining means, one of whose arms is secured to a wall of the pocket of the sheath, and is protectively covered, so as to protect the blade of a knife engaged in the clip between the protected arm and the other arm of the clip, and so as to provide a friction-producing component, which enhances the knife-retaining action of the sheath.

Another object of the invention is to provide, in a knife sheath of the character indicated above, a retaining clip which is designed to frictionally grip the thicker or back edge area of a knife blade, with the cutting edge area of the blade extending out of the clip.

A further object of the invention is to provide a knife sheath of the character indicated above, wherein the pocket of the sheath is transversely tapered, and the retaining clip is located in the wider part of the pocket and the cutting edge of a knife blade is protectively disposed in the narrower part of the pocket.

A still further object of the invention is to provide a knife sheath of the character indicated above wherein the incorporation therein of a retaining clip of the character indicated above adds little to the cost of manufacture of the sheath, and weight, of the sheath, and makes no increase in the bulk of the sheath.

Other important objects and advantageous features of the invention will be apparent from the following description and the accompanying drawings, wherein, for purposes of illustration only, a specific form of the invention is set forth in detail.

In the drawings:

FIGURE 1 is a side elevation of a knife sheath of the invention, showing a knife with its blade inserted in and retainably secured in the sheath;

FIGURE 2 is an enlarged horizontal section taken on the line 2-2 of FIGURE 1; and

FIGURE 3 is a perspective view of the sheath in a partially completed condition.

Referring in detail to the drawings, wherein like numerals designate like parts throughout the several views, the illustrated knife sheath, generally designated 10, comprises a preferably one-piece, generally L-shaped blank of flexible sheet material, such as leather, comprising a vertically elongated, double rear panel 11 which includes a parallel-sided, generally rectangular upper portion 12, having side edges 14 and 16, and a lower portion 18, which has a downwardly and laterally inwardly curved free side edge 20, which is a continuation of the side edge 14, and a vertical straight fold 22 which is a continuation of the side edge 16. The fold 22 serves as the connection to the lower rear wall portion 12 of a front wall 24, which has the same shape as the lower portion 18, and has a curved free side edge 26, which is secured coextensively to and along the curved side edge 20, by suitable means, such as stitching 28, so as to form a knife blade pocket 30, having an upper edge 32. The upper portion rear wall portion 12 is provided with suitable belt attachment means, such as a pair of spaced vertical slots 34. The rear panel 11 is composed of a rear ply 13 and a front panel 15, these panels being coextensive and se-

2

cured together along their edges, as indicated at 17. The fold 22 is a continuation of the rear ply 13.

As seen in FIGURE 2, the fold 22 is designedly broad and curved, rather than sharp and creased, so that the cross section of the knife blade pocket 30 has a comma-shaped cross section, with the narrower side 36 thereof not substantially wider than the tapered cutting edge portion 38 of a knife blade 40, of such as a hunting knife 32, having a handle 44, and a flanged guard 46 between the handle and the blade, which is adapted to bear upon the upper edge 32 of the pocket 30, as shown in FIGURE 1.

Located in the wider side 48 of the pocket 30 is retaining spring clip 50, preferably of non-corrosive metal, which, preferably comprises a single length of flat spring strip, which includes a flat, horizontally elongated rear arm 52, which bears against the front side of the lower portion of the front ply 15 of the rear panel 11 and behind the front ply 15 thereof, at a point near to and spaced downwardly from the upper edge 32 of the pocket 30, and is secured in place, by suitable means, such as a headed rivet 54, extending through the arm 52 and the rear ply 13. The clip 50 further comprises, on its end adjacent to the fold 22, a preferably integral forward gripping arm 56. As seen in FIGURE 2, the rear clip arm 52 is shorter than the width of the pocket 30, and has a free end 58 which is spaced from the narrower side 36 of the pocket 30.

As seen in FIGURE 2, the forward gripping arm 56 of the clip 50 is curved laterally outwardly, forwardly, laterally inwardly, and rearwardly to a free end 60, and is tensioned rearwardly toward the rear arm 52. The curvature of the forward arm 56 is preferably substantially uniform and arcuate, and the diameter of the arm 58 is such that it occupies the space between the rear arm 52 and forward or front wall 24, and bears supportably against and gives arcuate form to the fold 22. On the free end 60 of the forward gripping arm 56 a reversely curved terminal 62, which curves away from the rear arm 52, and provides for easy and non-marring insertion of the point and the back edge 64 of the knife blade 40 into place between the clip arm 56 and the front ply 15, as the blade 40 is inserted downwardly in and is moved laterally into place therebetween. As seen in FIGURES 1 and 3, the clip 50 is of substantial vertical dimension, the forward arm 56 preferably being greater in height than in lateral or horizontal width, so as to provide the forward arm 56 with substantial gripping tension and with a relatively wide bearing upon a knife blade, without being required to be of relatively thick or heavy gauge.

The forward head 66 of the rivet 54 is preferably inset in an opening 55 in the front ply 15, in order to provide a non-marring surface on the front ply 15 covering the rear clip arm 52, and at the same time provide a knife blade engaging friction medium more effective than the surface of the rear clip arm 52.

It will be evident from the foregoing, and from the drawings, that a knife blade 40 inserted downwardly in the pocket 30 between the forward gripping arm 56 of the clip 50 and the front ply 15 of the rear panel 11, will be held securely against accidental removal from the pocket and against being joggled out of the pocket, but can be easily and quickly removed from the sheath by drawing upwardly on the handle 44, preferably with an accompanying slight forward pressure on the handle 44, so as to spread the gripping arm 56 of the clip 50 away from the rear panel 11.

Although there has been shown and described herein a preferred form of the invention, it is to be understood that the invention is not necessarily confined thereto, and that any change or changes in the structure of and in the relative arrangements of components thereof are con-

templated as being within the scope of the invention as defined by the claims appended hereto.

What is claimed is:

1. A knife sheath comprising a rear panel, a front wall secured along its edges to related edges of the rear panel and defining a pocket, and a spring clip located within the pocket and extending in a transverse direction with respect to the longitudinal axis of the pocket and having a transversely-extending rear arm fixed to said rear panel, and a transversely-extending forward gripping arm fixed at one end to said rear arm and having a free end, said forward arm being rearwardly tensioned toward said rear arm, said pocket having an upper edge, said clip being located below and near to the upper edge of the pocket, said rear clip arm being substantially flat, and said forward clip arm being laterally outwardly, forwardly, laterally inwardly, and rearwardly curved toward said free end, said forward clip arm being arcuately curved, a broadly curved fold securing said front wall to a related side edge of the rear panel and giving said pocket a relatively narrow side and a relatively wide side, said clip being located in the wide side of the pocket, with said forward clip arm being supportably engaged with said fold and the forward wall.

2. A knife sheath comprising a rear panel, a front wall secured along its edges to related edges of the rear panel and defining a pocket, and a spring clip located within the pocket and extending in a transverse direction with respect to the longitudinal axis of the pocket and having a transversely-extending rear arm fixed to said rear panel, and a transversely-extending forward gripping arm fixed at one end to said rear arm and having a free end, said forward arm being rearwardly tensioned toward said rear arm, said pocket having an upper edge, said clip being located below and near to the upper edge of the pocket, said rear clip arm being substantially flat, and said forward clip arm being laterally outwardly, forwardly, laterally inwardly, and rearwardly curved toward said free end, said forward clip arm being arcuately curved, a broadly curved fold securing said front wall to a related side edge of the rear panel and giving said pocket a relatively narrow side and a relatively wide side, said clip being located in the wide side of the pocket, with said forward clip arm being supportably engaged with said fold and the forward wall, said forward clip arm being on an end of the rear clip arm, said rear clip arm having a free end

spaced from adjacent edges of the rear panel and front wall, and a pad extending across the front of the rear panel between the free end of the forward clip arm and said rear panel.

3. A knife sheath comprising a rear panel, a front wall secured along its edges to related edges of the rear panel and defining a pocket, and a spring clip located within the pocket and extending in a transverse direction with respect to the longitudinal axis of the pocket and having a transversely-extending rear arm fixed to said rear panel, and a transversely-extending forward gripping arm fixed at one end to said rear arm and having a free end, said forward arm being rearwardly tensioned toward said rear arm, said rear panel comprising a rear ply and a front ply, said rear clip arm being disposed between said front and rear plies, a rivet extending through said rear ply and said rear clip arm and securing the latter in place, the front ply having an opening registered with said rivet, the adjacent end of the rivet being inset in said opening.

4. A sheath for a knife having a handle and a blade, said sheath comprising a blade pocket of substantially the length of a knife blade, said pocket comprising front and rear panels, a spring clip disposed within said pocket and extending in a transverse direction with respect to the longitudinal axis of the pocket and comprising a transversely-extending rear arm secured to said rear panel and a transversely-extending forward arm, said forward arm having a free end facing and spaced from a side of the pocket, said forward arm being forwardly curved between its ends, and a pad secured to the forward side of the rear panel, the rear clip arm being disposed between the pad and the rear panel with the free end of the forward clip arm bearing against the forward side of the pad.

References Cited in the file of this patent

UNITED STATES PATENTS

1,092,244	Coolidge	Apr. 7, 1914
1,439,310	Hay et al.	Dec. 19, 1922
1,610,535	Smith	Dec. 14, 1926
2,109,232	Hoyt	Feb. 22, 1938
2,387,900	Hartwell	Oct. 30, 1945
2,528,501	Davis	Nov. 7, 1950

FOREIGN PATENTS

107,863	Austria	Nov. 10, 1927
---------	---------	---------------