



(11) **EP 1 876 291 A2**

(12) **EUROPEAN PATENT APPLICATION**

(43) Date of publication:
09.01.2008 Bulletin 2008/02

(51) Int Cl.:
D21F 11/00 (2006.01) D21F 1/00 (2006.01)

(21) Application number: **07019184.6**

(22) Date of filing: **17.10.2002**

(84) Designated Contracting States:
DE FR GB IT

- **Lindsay, Jeffrey D.**
Appleton, WI 54915 (US)
- **Chiu, Kai F.**
Bellvue, WA 98004 (US)

(30) Priority: **02.11.2001 US 15838**
02.11.2001 US 15858

(74) Representative: **Davies, Christopher Robert**
Frank B. Dehn & Co.
St Bride's House
10 Salisbury Square
London EC4Y 8JD (GB)

(62) Document number(s) of the earlier application(s) in accordance with Art. 76 EPC:
02784144.4 / 1 440 195

(71) Applicant: **KIMBERLY-CLARK WORLDWIDE, INC.**
Neenah, WI 54956 (US)

Remarks:

This application was filed on 28 - 09 - 2007 as a divisional application to the application mentioned under INID code 62.

(72) Inventors:
• **Burazin, Mark Alan**
Oshkosh, WI 54902 (US)

(54) **Fabric for use in the manufacture of tissue products having visually discernable background texture regions bordered by curvilinear decorative elements**

(57) The present invention is a woven sculpted fabric for the manufacture of a tissue web having a tissue contacting surface and a method for making such a woven sculpted fabric. The tissue contacting surface of the woven sculpted fabric includes at least a first group of strands and a second group of strands wherein the first group of strands extend in a first direction and the second group of strands extend in a second direction. The first group of strands are adapted to produce elevated floats and depressed sinkers thereby defining a three-dimensional fabric surface comprising; a first background region having a set of substantially parallel first elevated floats separated by a set of substantially parallel first depressed sinkers, comprising first depressed sinkers positioned between adjacent first elevated floats and com-

prising first elevated floats positioned between adjacent first depressed sinkers; a second background region having a set of substantially parallel second elevated floats separated by a set of substantially parallel second depressed sinkers, comprising second depressed sinkers positioned between adjacent second elevated floats and comprising second elevated floats positioned between adjacent a second depressed sinkers; and, a transition region positioned between the first and second background regions, wherein the first elevated floats of the first background region become the second elevated floats of the second background region and the first depressed sinkers of the first background region become the second depressed sinkers of the second background region.

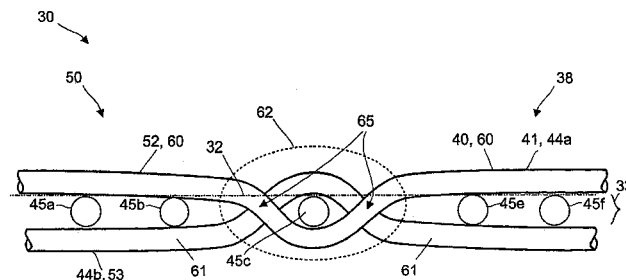

FIGURE 8

EP 1 876 291 A2

Description

BACKGROUND

[0001] The present invention relates to the field of paper manufacturing. More particularly, the present invention relates to the manufacture of absorbent tissue products such as bath tissue, facial tissue, napkins, towels, wipers, and the like. Specifically, the present invention relates to improved fabrics used to manufacture absorbent tissue products having visually discernible background texture regions bordered by curvilinear decorative elements, methods of tissue manufacture, methods of fabric manufacture, and the actual tissue products produced.

[0002] In the manufacture of tissue products, particularly absorbent tissue products, there is a continuing need to improve the physical properties and final product appearance. It is generally known in the manufacture of tissue products that there is an opportunity to mold a partially dewatered cellulosic web on a papermaking fabric specifically designed to enhance the finished paper product's physical properties. Such molding can be applied by fabrics in an uncreped through air dried process as disclosed in U.S. Patent No. 5,672,248 issued on September 30, 1997 to Wendt et al., or in a wet pressed tissue manufacturing process as disclosed U.S. Patent No. 4,637,859 issued on January 20, 1987 to Trokhan. Wet molding typically imparts desirable physical properties independent of whether the tissue web is subsequently creped, or an uncreped tissue product is produced.

[0003] However, absorbent tissue products are frequently embossed in a subsequent operation after their manufacture on the paper machine, while the dried tissue web has a low moisture content, to impart consumer preferred visually appealing textures or decorative lines. Thus, absorbent tissue products having both desirable physical properties and pleasing visual appearances often require two manufacturing steps on two separate machines. Hence, there is a need to combine the generation of visually discernible background texture regions bordered by curvilinear decorative elements with the paper manufacturing process to reduce manufacturing costs. There is also a need to develop a paper manufacturing process that not only imparts visually discernible background texture regions bordered by curvilinear decorative elements to the sheet, but also maximizes desirable physical properties of the absorbent tissue products without deleteriously affecting other desirable physical properties.

[0004] Previous attempts to combine the above needs, such as those disclosed in U.S. Patent No. 4,967,805 issued on November 6, 1990 to Chiu, U.S. Patent No. 5,328,565 issued on July 12, 1994 to Rasch et al., and in U.S. Patent No. 5,820,730 issued on October 13, 1998 to Phan et al., have manipulated the papermaking fabric's drainage in different localized regions to produce a pat-

tern in the wet tissue web in the forming section of the paper machine. Thus, the texture results from more fiber accumulation in areas of the fabric having high drainage and fewer fibers in areas of the fabric having low drainage. Such a method can produce a dried tissue web having a non-uniform basis weight in the localized areas or regions arranged in a systematic manner to form the texture. While such a method can produce textures, the sacrifice in the uniformity of the dried tissue web's physical properties such as tear, burst, absorbency, and density can degrade the dried tissue web's performance while in use.

[0005] For the foregoing reasons, there is a need to generate aesthetically pleasing combinations of background texture regions and curvilinear decorative elements in the dried or partially dried tissue web, while being manufactured on the paper machine, using a method that produces a substantially uniform density dried tissue web which has improved performance while in use.

[0006] Numerous woven fabric designs are known in papermaking. Examples are provided by Sabut Adanur in Paper Machine Clothing, Lancaster, Pennsylvania: Technomic Publishing, 1997, pp. 33 - 113, 139 - 148, 159 - 168, and 211 - 229. Another example is provided in Patent Application WO 00/63489, entitled "Paper Machine Clothing and Tissue Paper Produced with Same," by H.J. Lamb, published on October 26, 2000.

SUMMARY

[0007] The present invention comprises paper manufacturing processes that may satisfy one or more of the foregoing needs. For example, a paper manufacturing fabric of the present invention, when used as a through-drying fabric in an uncreped tissue making process, produces an absorbent tissue product having a substantially uniform density as well as possessing visually discernible background texture regions bordered by curvilinear decorative elements. The present invention is also directed towards fabrics for manufacturing the absorbent tissue product, processes of making the absorbent tissue product, processes of making the fabric, and the absorbent tissue products themselves.

[0008] Therefore in one aspect, the present invention relates to a fabric for producing an absorbent tissue product with visually discernible background texture regions bordered by curvilinear decorative elements comprising: a woven fabric having background texture regions formed by MD warp floats alternating with MD warp sinkers woven into a support structure (i.e., at least a single layer of CD shutes) below the MD floats; the warps and shutes at the borders of the background texture regions are arrayed to form transition regions comprising the curvilinear decorative elements.

[0009] In another aspect, the present invention relates to a method for manufacturing an absorbent tissue product with visually discernible background texture regions bordered by curvilinear decorative elements comprising:

forming the wet tissue web, partially dewatering the wet tissue web, rush transferring the wet tissue web, wet molding the wet tissue web into a fabric having visually discernible background texture regions bordered by curvilinear decorative elements, and throughdrying the web.

[0010] In an additional aspect, the present invention relates to a tissue product with background texture regions bordered by curvilinear decorative elements that form aesthetically pleasing repeating patterns comprising: visually discernible background texture regions of MD ripples, ridges, or the like, corresponding to a image of the background texture regions of the fabric, bordered by curvilinear decorative elements, corresponding to an image of the curvilinear transition regions of the fabric, where the curvilinear decorative elements in the tissue web are visually distinct from the background texture regions in the tissue.

[0011] Unlike U.S. Patent No. 5,672,248 issued on September 30, 1997 to Wendt et al., where the warp knuckles are closely spaced or contacting and arranged into patterns, the present invention produces the curvilinear decorative elements in the absorbent tissue product at a substantially continuous transition region which forms borders between background texture regions. The curvilinear decorative elements comprise geometric configurations with the leading end of one or more raised MD floats adjacent to or in proximity to the trailing end of another raised MD float. The decorative pattern consists of the visually discernible background texture regions, such as corrugations, lines, ripples, ridges, and the like, and the curvilinear decorative elements which form transition regions between the background texture regions. It is the arrangement of the transition regions in the present invention that provide the decorative pattern. Because the curvilinear decorative elements are produced at the transition region (rather than from a decorative pattern resulting from shoulder to shoulder or side by side positioning of warp knuckles of other fabrics) the raised MD floats can be purposely distributed more uniformly across the sheet side surface of the fabric to improve the uniformity and CD stretch properties of the tissue web with respect to physical properties while still imparting a distinctive texture highlighted by curvilinear decorative elements as a decorative pattern to the tissue web. In addition, because the curvilinear decorative elements producing the distinctive pattern occurs at the relatively small transition area, it is possible to weave the fabric with more intricate patterns than possible in the fabrics disclosed in U.S. Patent No. 5,672,248.

[0012] The background texture regions are designed to impart preferred finished product properties when used as an UCTAD throughdrying fabric, including roll bulk, stack bulk, CD stretch, drape, and durability. The curvilinear decorative elements may provide additional hinge points to enhance finished product drape. The background texture regions in the finished product contrast visually with the curvilinear transition regions, providing the decorative effect.

[0013] In one aspect of the present invention, the curvilinear decorative elements form woven transition regions which allow the warps to alternate function between MD warp float and MD warp sinker. When finished so the warps are parallel to the MD, the background texture regions across each transition region are out of phase with each other, with the highest parts of one background texture region corresponding to the lowest part of the other. This out of phase alternation results in improved anti-
nesting behavior, significantly improving the roll firmness - roll bulk relationship at a given one-sheet caliper.

[0014] In some embodiments, all of the floats (or elevated regions) in a background region are surrounded by sinkers (or depressed regions), with the possible exception of floats adjacent to a transition region or fabric edge, and all of the sinkers (or depressed regions) in a background region are surrounded by floats (or elevated regions), with the possible exception of sinkers adjacent to a transition region or fabric edge.

BRIEF DESCRIPTION OF THE DRAWINGS

[0015] These and other features, aspects, and advantages of the present invention will be better understood with regard to the following description, appended claims, and accompanying drawings where:

FIGURE 1A is a schematic diagram of one embodiment of the fabric of the present invention.

FIGURE 1B is a schematic diagram of one embodiment of the fabric of the present invention.

FIGURE 2 is a schematic diagram of one embodiment of the fabric of the present invention.

FIGURE 3 is a cross-sectional view of one embodiment of the fabric of the present invention.

FIGURE 4 is a cross-sectional view of one embodiment of the fabric of the present invention.

FIGURE 5 is a cross-sectional view of one embodiment of the fabric of the present invention.

FIGURE 6 is a cross-sectional view of one embodiment of the fabric of the present invention.

FIGURE 7 is a schematic diagram of a surface profile and corresponding material lines of one embodiment of the fabric of the present invention.

FIGURE 8 is a cross-sectional view of one embodiment of the fabric of the present invention.

FIGURE 9 is a schematic diagram of one embodiment of the fabric of the present invention.

FIGURE 10 is a CADEYES display screen shot of a putty impression of one embodiment of the fabric of the present invention.

FIGURE 11 is a CADEYES display screen shot of dried tissue molded on one embodiment of the fabric of the present invention.

FIGURE 12 is a CADEYES display screen shot of dried tissue molded on one embodiment of the fabric of the present invention.

FIGURE 13 is a CADEYES display screen shot of dried tissue molded on one embodiment of the fabric of the present invention.

FIGURE 14 is a CADEYES display screen shot of dried tissue molded on one embodiment of the fabric of the present invention.

FIGURE 15 is a CADEYES display screen shot of dried tissue molded on one embodiment of the fabric of the present invention.

FIGURE 16 is a CADEYES display screen shot of a putty impression of one embodiment of the fabric of the present invention.

FIGURE 17 is a CADEYES display screen shot of a putty impression of one embodiment of the fabric of the present invention.

FIGURE 18 is a schematic diagram of one embodiment of the fabric of the present invention.

FIGURE 19 is a schematic diagram of one embodiment of the fabric of the present invention.

FIGURE 20 is a schematic diagram of one embodiment of the fabric of the present invention.

FIGURE 21 is a schematic diagram of one embodiment of the fabric of the present invention.

FIGURE 22 is a schematic diagram of one embodiment of the fabric of the present invention:

FIGURE 23 is a CADEYES display screen shot of a putty impression of one embodiment of the fabric of the present invention.

FIGURE 24 is a CADEYES display screen shot of a putty impression of one embodiment of the fabric of the present invention.

FIGURE 25 is a schematic diagram of one embodiment of the fabric of the present invention.

FIGURE 26A is a schematic diagram of one embodiment of the fabric of the present invention.

FIGURE 26B is a schematic diagram of one embodiment of the fabric of the present invention.

FIGURE 26C is a schematic diagram of one embodiment of the fabric of the present invention.

FIGURE 26D is a schematic diagram of one embodiment of the fabric of the present invention.

FIGURE 26E is a schematic diagram of one embodiment of the fabric of the present invention.

FIGURE 27 is a schematic diagram for making an uncreped dried tissue web in accordance with an embodiment of the present invention.

FIGURE 28 is a photograph of one embodiment of the fabric of the present invention.

FIGURE 29 is a photograph of the air side of a dried tissue web made using one embodiment of the fabric of the present invention.

FIGURE 30 is a photograph of the fabric side of a dried tissue web made using one embodiment of the fabric of the present invention.

DEFINITIONS

[0016] As used herein, "**curvilinear decorative element**" refers to any line or visible pattern that contains either straight sections, curved sections, or both that are substantially connected visually. Thus, a decorative pattern of interlocking circles may be formed from many curvilinear decorative elements shaped into circles. Similarly, a pattern of squares may be formed from many curvilinear decorative elements shaped into individual squares. It is understood that curvilinear decorative elements also may appear as undulating lines, substantially connected visually, forming signatures or patterns as well as multiple warp mixed with single warp to generate textures of more complicated patterns.

[0017] Also, as used herein "**decorative pattern**" refers to any non-random repeating design, figure, or motif. It is not necessary that the curvilinear decorative elements form recognizable shapes, and a repeating design of the curvilinear decorative elements is considered to constitute a decorative pattern.

[0018] As used herein, the term "**float**" means an unwoven or non-interlocking portion of a warp emerging from the topmost layer of shutes that spans at least two consecutive shutes of the topmost layer of shutes.

[0019] As used herein, a "**sinker**" means a span of a warp that is generally depressed relative to adjacent floats, further having two end regions both of which pass

under one or more consecutive shutes.

[0020] As used herein, "**machine-direction**" or "**MD**" refers to the direction of travel of the fabric, the fabric's individual strands, or the paper web while moving through the paper machine. Thus, the MD test data for the tissue refers to the tissue's physical properties in a sample cut lengthwise in the machine-direction. Similarly, "**cross-machine direction**" or "**CD**" refers to a direction orthogonal to the machine-direction extending across the width of the paper machine. Thus, the CD test data for the tissue refers to the tissue's physical properties in a sample cut lengthwise in the cross-machine direction. In addition, the strands may be arranged at acute angles to the MD and CD directions. One such arrangement is described in "Rolls of Tissue Sheets Having Improved Properties", Burazin et al., EP 1 109 969 A1 which published on June 27, 2001 and incorporated herein by reference to the extent it is not contradictory herewith.

[0021] As used herein, "**plane difference**" refers to the z-direction height difference between an elevated region and the highest immediately adjacent depressed region. Specifically, in a woven fabric, the plane difference is the z-direction height difference between a float and the highest immediately adjacent sinker or shute. Z-direction refers to the axis mutually orthogonal to the machine direction and cross-machine direction.

[0022] As used herein, "**transfer fabric**" is a fabric that is positioned between the forming section and the drying section of the web manufacturing process.

[0023] As used herein, "**transition region**" is defined as the intersection of three or more floats on three or more consecutive MD strands. The transition regions are formed by deliberate interruptions in the textured background regions, which may result from a variety of arrangements of intersections of the floats. The floats may be arranged in an overlapping intersection or in a non-overlapping intersection.

[0024] As used herein, a "**filled**" transition region is defined as a transition region where the space between the floats in the transition region is partially or completely filled with material, raising the height in the transition area. The filling material may be porous. The filling material may be any of the materials discussed hereinafter for use in the construction of fabrics. The filling material may be substantially deformable, as measured by High Pressure Compressive Compliance (defined hereinafter).

[0025] As used herein, the term "**warp**" can be understood as a strand substantially oriented in the machine direction, and "**shute**" can be understood to refer to the strands substantially oriented in the cross-machine direction of the fabric as used on a papermachine. The warps and shutes may be interwoven via any known fabric method of manufacture. In the production of endless fabrics, the normal orientation of warps and shutes, according to common weaving terminology, is reversed, but as used herein, the structure of the fabric and not its method of manufacture determine which strands are classified as warps and which are shutes.

[0026] As used herein "**strand**" refers a substantially continuous filament suitable for weaving sculptured fabrics of the present invention. Strands may include any known in the prior art. Strands may comprise monofilament, cabled monofilament, staple fiber twisted together to form yarns, cabled yarns, or combinations thereof. Strand cross-sections, filament cross sections, or stable fiber cross sections may be circular, elliptical, flattened, rectangular, oval, semi-oval, trapezoidal, parallelogram, polygonal, solid, hollow, sharp edged, rounded edged, bi-lobal, multi-lobal, or can have capillary channels. Strand diameter or strand cross sectional shape may vary along its length.

[0027] As used herein "**multi-strand**" refers to two or more strands arranged side by side or twisted together. It is not necessary for each side-by-side strand in a multi-strand group to be woven identically. For example, individual strands of a multi-strand warp may independently enter and exit the topmost layer of shutes in sinker regions or transition regions. As a further example, a single multi-strand group need not remain a single multi-strand group throughout the length of the strands in the fabric, but it is possible for one or more strands in a multi-strand group to depart from the remaining strand(s) over a specific distance and serve, for example, as a float or sinker independently of the remaining strand(s).

[0028] As used herein, "**Frazier air permeability**" refers to the measured value of a well-known test with the Frazier Air Permeability Tester in which the permeability of a fabric is measured as standard cubic feet of air flow per square foot of material per minute with an air pressure differential of 0.5 inches (12.7 mm) of water under standard conditions. The fabrics of the present invention can have any suitable Frazier air permeability. For example, though drying fabrics can have a permeability from about 55 standard cubic feet per square foot per minute (about 16 standard cubic meters per square meter per minute) or higher, more specifically from about 100 standard cubic feet per square foot per minute (about 30 standard cubic meters per square meter per minute) to about 1,700 standard cubic feet per square foot per minute (about 520 standard cubic meters per square meter per minute), and most specifically from about 200 standard cubic feet per square foot per minute (about 60 standard cubic meters per square meter per minute) to about 1,500 standard cubic feet per square foot per minute (about 460 standard cubic meters per square meter per minute).

DETAILED DESCRIPTION

The Process

[0029] Referring to **FIGURE 27**, a process of carrying out the present invention will be described in greater detail. The process shown depicts an uncreped through dried process, but it will be recognized that any known papermaking method or tissue making method can be used in conjunction with the fabrics of the present inven-

tion. Related uncreped through air dried tissue processes are described in U.S. Patent No. 5,656,132 issued on August 12, 1997 to Farrington et al. and in U.S. Patent No. 6,017,417 issued on January 25, 2000 to Wendt et al. Both patents are herein incorporated by reference to the extent they are not contradictory herewith. In addition, fabrics having a sculpture layer and a load bearing layer useful for making uncreped through air dried tissue products are disclosed in U.S. Patent No. 5,429,686 issued on July 4, 1995 to Chiu et al. also herein incorporated by reference to the extent it is not contradictory herewith. Exemplary methods for the production of creped tissue and other paper products are disclosed in U.S. Patent No. 5,855,739, issued on January 5, 1999 to Ampulski et al.; U.S. Patent No. 5,897,745, issued on April 27, 1999 to Ampulski et al.; U.S. Patent No. 5,893,965, issued on April 13, 1999 to Trokhan et al.; U.S. Patent No. 5,972,813 issued on October 26, 1999 to Polat et al.; U.S. Patent No. 5,503,715, issued on April 2, 1996 to Trokhan et al.; U.S. Patent No. 5,935,381, issued on August 10, 1999 to Trokhan et al.; U.S. Patent No. 4,529,480, issued on July 16, 1985 to Trokhan; U.S. Patent No. 4,514,345, issued on April 30, 1985 to Johnson et al.; U.S. Patent No. 4,528,239, issued on July 9, 1985 to Trokhan; U.S. Patent No. 5,098,522, issued on March 24, 1992 to Smurkoski et al.; U.S. Patent No. 5,260,171, issued on November 9, 1993 to Smurkoski et al.; U.S. Patent No. 5,275,700, issued on January 4, 1994 to Trokhan; U.S. Patent No. 5,328,565, issued on July 12, 1994 to Rasch et al.; U.S. Patent No. 5,334,289, issued on August 2, 1994 to Trokhan et al.; U.S. Patent No. 5,431,786, issued on July 11, 1995 to Rasch et al.; U.S. Patent No. 5,496,624, issued on March 5, 1996 to Steljes, Jr. et al.; U.S. Patent No. 5,500,277, issued on March 19, 1996 to Trokhan et al.; U.S. Patent No. 5,514,523, issued on May 7, 1996 to Trokhan et al.; U.S. Patent No. 5,554,467, issued on September 10, 1996, to Trokhan et al.; U.S. Patent No. 5,566,724, issued on October 22, 1996 to Trokhan et al.; U.S. Patent No. 5,624,790, issued on April 29, 1997 to Trokhan et al.; U.S. Patent No. 6,010,598, issued on January 4, 2000 to Boutillier et al.; and, U.S. Patent No. 5,628,876, issued on May 13, 1997 to Ayers et al., the specification and claims of which are incorporated herein by reference to the extent that they are not contradictory herewith.

[0030] In **Figure 27**, a twin wire former **8** having a papermaking headbox **10** injects or deposits a stream **11** of an aqueous suspension of papermaking fibers onto a plurality of forming fabrics, such as the outer forming fabric **12** and the inner forming fabric **13**, thereby forming a wet tissue web **15**. The forming process of the present invention may be any conventional forming process known in the papermaking industry. Such formation processes include, but are not limited to, Fourdriniers, roof formers such as suction breast roll formers, and gap formers such as twin wire formers and crescent formers.

[0031] The wet tissue web **15** forms on the inner forming fabric **13** as the inner forming fabric **13** revolves about

a forming roll **14**. The inner forming fabric **13** serves to support and carry the newly-formed wet tissue web **15** downstream in the process as the wet tissue web **15** is partially dewatered to a consistency of about **10** percent based on the dry weight of the fibers. Additional dewatering of the wet tissue web **15** may be carried out by known paper making techniques, such as vacuum suction boxes, while the inner forming fabric **13** supports the wet tissue web **15**. The wet tissue web **15** may be additionally dewatered to a consistency of at least about 20%, more specifically between about 20% to about 40%, and more specifically about 20% to about 30%. The wet tissue web **15** is then transferred from the inner forming fabric **13** to a transfer fabric **17** traveling preferably at a slower speed than the inner forming fabric **13** in order to impart increased MD stretch into the wet tissue web **15**.

[0032] The wet tissue web **15** is then transferred from the transfer fabric **17** to a throughdrying fabric **19** whereby the wet tissue web **15** preferably is macroscopically rearranged to conform to the surface of the throughdrying fabric **19** with the aid of a vacuum transfer roll **20** or a vacuum transfer shoe like the vacuum shoe **18**. If desired, the throughdrying fabric **19** can be run at a speed slower than the speed of the transfer fabric **17** to further enhance MD stretch of the resulting absorbent tissue product **27**. The transfer is preferably carried out with vacuum assistance to ensure conformation of the wet tissue web **15** to the topography of the throughdrying fabric **19**. This yields a dried tissue web **23** having the desired bulk, flexibility, CD stretch, and enhances the visual contrast between the background texture regions **38** and **50** and the curvilinear decorative elements which border the background texture regions **38** and **50**.

[0033] In one embodiment, the throughdrying fabric **19** is woven in accordance with the present invention, and it imparts the curvilinear decorative elements and background texture regions **38** and **50**, such as substantially broken-line like corduroy, to the wet tissue web **15**. It is possible, however, to weave the transfer fabric **17** in accordance with the present invention to achieve similar results. Furthermore, it is also possible to eliminate the transfer fabric **17**, and transfer the wet tissue web **15** directly to the throughdrying fabric **19** of the present invention. Both alternative papermaking processes are within the scope of the present invention, and will produce a decorative absorbent tissue product **27**.

[0034] While supported by the throughdrying fabric **19**, the wet tissue web **15** is dried to a final consistency of about 94 percent or greater by a throughdryer **21** and is thereafter transferred to a carrier fabric **22**. Alternatively, the drying process can be any noncompressive drying method that tends to preserve the bulk of the wet tissue web **15**.

[0035] In another aspect of the present invention, the wet tissue web **15** is pressed against a Yankee dryer by a pressure roll while supported by a woven sculpted fabric **30** comprising visually discernable background texture regions **38** and **50** bordered by curvilinear decorative el-

ements. Such a process, without the use of the sculpted fabrics **30** of the present invention, is shown in U.S. Patent No. 5,820,730 issued on October 13, 1998 to Phan et al. The compacting action of a pressure roll will tend to densify a resulting absorbent tissue product **27** in the localized regions corresponding to the highest portions of the sculpted fabric **30**.

[0036] The dried tissue web **23** is transported to a reel **24** using a carrier fabric **22** and an optional carrier fabric **25**. An optional pressurized turning roll **26** can be used to facilitate transfer of the dried tissue web **23** from the carrier fabric **22** to the carrier fabric **25**. If desired, the dried tissue web **23** may additionally be embossed to produce a combination of embossments and the background texture regions and curvilinear decorative elements on the absorbent tissue product **27** produced using the throughdrying fabric **19** and a subsequent embossing stage.

[0037] Once the wet tissue web **15** has been non-compressively dried, thereby forming the dried tissue web **23**, it is possible to crepe the dried tissue web **23** by transferring the dried tissue web **23** to a Yankee dryer prior to reeling, or using alternative foreshortening methods such as microcreping as disclosed in U.S. Patent No. 4,919,877 issued on April, 24, 1990 to Parsons et al.

[0038] In an alternative embodiment not shown, the wet tissue web **15** may be transferred directly from the inner forming fabric **13** to the throughdrying fabric **19** and the transfer fabric **17** eliminated. The throughdrying fabric **19** is constructed with raised MD floats **60**, and illustrative embodiments are shown in **FIGURES 1A, 1B, 2, 9, and 28**. The throughdrying fabric **19** may be traveling at a speed less than the inner forming fabric **13** such that the wet tissue web **15** is rush transferred, or, in the alternative, the throughdrying fabric **19** may be traveling at substantially the same speed as the inner forming fabric **13**. If the throughdrying fabric **19** is traveling at a slower speed than the speed of the inner forming fabric **13**, an uncreped absorbent tissue product **27** is produced. Additional foreshortening after the drying stage may be employed to improve the MD stretch of the absorbent tissue product **27**. Methods of foreshortening the absorbent tissue product **27** include, by way of illustration and without limitation, conventional Yankee dryer creping, microcreping, or any other method known in the art.

[0039] Differential velocity transfer from one fabric to another can follow the principles taught in any one of the following patents, each of which is herein incorporated by reference to the extent it is not contradictory herewith: U.S. Patent No. 5,667,636, issued on September 16, 1997 to Engel et al.; U.S. Patent No. 5,830,321, issued on November 3, 1998 to Lindsay et al.; U.S. Patent No. 4,440,597, issued on April 3, 1984 to Wells et al.; U.S. Patent No. 4,551,199, issued on November 5, 1985 to Weldon; and, U.S. Patent No. 4,849,054, issued on July 18, 1989 to Klowak.

[0040] In yet another alternative embodiment of the present invention, the inner forming fabric **13**, the transfer

fabric **17**, and the throughdrying fabric **19** can all be traveling at substantially the same speed. Foreshortening may be employed to improve MD stretch of the absorbent tissue product **27**. Such methods include, by way of illustration without limitation, conventional Yankee dryer creping or microcreping.

[0041] Any known papermaking or tissue manufacturing method may be used to create a three-dimensional web **23** using the fabrics **30** of the present invention as a substrate for imparting texture to the wet tissue web **15** or the dried tissue web **16**. Though the fabrics **30** of the present invention are especially useful as through drying fabrics and can be used with any known tissue making process that employs throughdrying, the fabrics **30** of the present invention can also be used in the formation of paper webs as forming fabrics, transfer fabrics, carrier fabrics, drying fabrics, imprinting fabrics, and the like in any known papermaking or tissue making process. Such methods can include variations comprising any one or more of the following steps in any feasible combination:

- web formation in a wet end in the form of a classical Fourdrinier, a gap former, a twin-wire former, a crescent former, or any other known former comprising any known headbox, including a stratified headbox for bringing layers of two or more furnishes together into a single web, or a plurality of headboxes for forming a multilayered web, using known wires and fabrics or fabrics of the present invention;
- web formation or web dewatering by foam-based processes, such as processes wherein the fibers are entrained or suspended in a foam prior to dewatering, or wherein foam is applied to an embryonic web prior to dewatering or drying, including the methods disclosed in U.S. Patent 5,178,729, issued on January 12, 1993 to Janda, and U.S. Patent No. 6,103,060, issued on August 15, 2000 to Munerelle et al., both of which are herein incorporated by reference to the extent they are not contradictory herewith;
- differential basis weight formation by draining a slurry through a forming fabric having high and low permeability regions, including fabrics of the present invention or any known forming fabric;
- rush transfer of a wet web from a first fabric to a second fabric moving at a slower velocity than the first fabric, wherein the first fabric can be a forming fabric, a transfer fabric, or a throughdrying fabric, and wherein the second fabric can be a transfer fabric, a throughdrying fabric, a second throughdrying fabric, or a carrier fabric disposed after a throughdrying fabric (one exemplary rush transfer process is disclosed in U.S. Patent No. 4,440,597 to Wells et al, herein incorporated by reference to the extent it is not contradictory herewith), wherein the aforementioned fabrics can be selected from any known suitable fabric including fabrics of the present invention;

- application of differential air pressure across the web to mold it into one or more of the fabrics on which the web rests, such as using a high vacuum pressure in a vacuum transfer roll or transfer shoe to mold a wet web into a throughdrying fabric as it is transferred from a forming fabric or intermediate carrier fabric, wherein the carrier fabric, throughdrying fabric, or other fabrics can be selected from the fabrics of the present invention or other known fabrics;
- use of an air press or other gaseous dewatering methods to increase the dryness of a web and/or to impart molding to the web, as disclosed in U.S. Patent No. 6096169, issued on August 1, 2000 to Hermans et al.; U.S. Patent No. 6,197,154, issued on March 6, 2001 to Chen et al.; and, U.S. Patent No. 6,143,135, issued on November 7, 2000 to Hada et al., all of which are herein incorporated by reference to the extent they are not contradictory herewith;
- drying the web by any compressive or noncompressive drying process, such as throughdrying, drum drying, infrared drying, microwave drying, wet pressing, impulse drying (e.g., the methods disclosed in U.S. Patent No. 5,353,521, issued on October 11, 1994 to Orloff and U.S. Patent No. 5,598,642, issued on February 4, 1997 to Orloff et al.), high intensity nip dewatering, displacement dewatering (see J.D. Lindsay, "Displacement Dewatering To Maintain Bulk," Paperi Ja Puu, vol. 74, No. 3, 1992, pp. 232-242), capillary dewatering (see any of U.S. Patent Nos. 5,598,643; 5,701,682; and 5,699,626, all of which issued to Chuang et al.), steam drying, etc.
- printing, coating, spraying, or otherwise transferring a chemical agent or compound on one or more sides of the web uniformly or heterogeneously, as in a pattern, wherein any known agent or compound useful for a web-based product can be used (e.g., a softness agent such as a quaternary ammonium compound, a silicone agent, an emollient, a skin-wellness agent such as aloe vera extract, an antimicrobial agent such as citric acid, an odor-control agent, a pH control agent, a sizing agent; a polysaccharide derivative, a wet strength agent, a dye, a fragrance, and the like), including the methods of U.S. Patent No. 5,871,763, issued on February 16, 1999 to Luu et al.; U.S. Patent No. 5,716,692, issued on February 10, 1998 to Warner et al.; U.S. Patent No. 5,573,637, issued on November 12, 1996 to Ampulski et al.; U.S. Patent No. 5,607,980, issued on March 4, 1997 to McAtee et al.; U.S. Patent No. 5,614,293, issued on March 25, 1997 to Krzysik et al.; U.S. Patent No. 5,643,588, issued on July 1, 1997 to Roe et al.; U.S. Patent No. 5,650,218, issued on July 22, 1997 to Krzysik et al.; U.S. Patent No. 5,990,377, issued on November 23, 1999 to Chen et al.; and, U.S. Patent No. 5,227,242, issued on July 13, 1993 to Walter et al., each of which is herein incorporated by reference to the extent they are not contradictory herewith;
- imprinting the web on a Yankee dryer or other solid

surface, wherein the web resides on a fabric that can have deflection conduits (openings) and elevated regions (including the fabrics of the present invention), and the fabric is pressed against a surface such as the surface of a Yankee dryer to transfer the web from the fabric to the surface, thereby imparting densification to portions of the web that were in contact with the elevated regions of the fabric, whereafter the selectively densified web can be creped from or otherwise removed from the surface;

- creping the web from a drum dryer, optionally after application of a strength agent such as latex to one or more sides of the web, as exemplified by the methods disclosed in U.S. Patent No. 3,879,257, issued on April 22, 1975 to Gentile et al.; U.S. Patent No. 5,885,418, issued on March 23, 1999 to Anderson et al.; U.S. Patent No. 6,149,768, issued on November 21, 2000 to Hepford, all of which are herein incorporated by reference to the extent they are not contradictory herewith;
- creping with serrated crepe blades (e.g., see U.S. Patent No. 5,885,416, issued on March 23, 1999 to Marinack et al.) or any other known creping or foreshortening method; and,
- converting the web with known operations such as calendering, embossing, slitting, printing, forming a multiply structure having two, three, four, or more plies, putting on a roll or in a box or adapting for other dispensing means, packaging in any known form, and the like.

[0042] The fabrics 30 of the present invention can also be used to impart texture to airlaid webs, either serving as a substrate for forming a web, for embossing or imprinting an airlaid web, or for thermal molding of a web.

Fabric Structure

[0043] **Figure 1A** is a schematic showing the relative placement of the floats **60** on the paper-contacting side of the woven sculpted fabric **30** according to the present invention. The floats **60** consist of the elevated portions of the warps **44** (strands substantially oriented in the machine direction). Not shown for clarity are the shutes (strands substantially oriented in the cross-machine direction) and depressed portions of the warps **44** interwoven with the shutes, but it is understood that the warps **44** can be continuous in the machine direction, periodically rising to serve as a float **60** and then descending as one moves horizontally in the portion of the woven sculpted fabric **30** schematically shown in **Figure 1A**.

[0044] In a first background region **38** of the woven sculpted fabric **30**, the floats **60** define a first elevated region **40** comprising first elevated strands **41**. Between each pair of neighboring first elevated strands **41** in the first background region **38** is a first depressed region **42**. The depressed warps **44** in the first depressed region **42** are not shown for clarity. The combination of machine-

direction oriented, alternating elevated and depressed regions forms a first background texture **39**.

[0045] In a second background region **50** of the woven sculpted fabric **30**, there are second elevated strands **53** defining a second elevated region **52**. Between each pair of the neighboring second elevated strands **53** in the second background region **50** is a second depressed region **54**. The depressed warps **44** in the second depressed region **54** are not shown for clarity. The combination of machine-direction oriented, alternating second elevated and depressed regions **52** and **54** forms a second background texture **51**.

[0046] Between the first background region **38** and the second background region **50** is a transition zone **62** where the floats **44** from either the first background region **38** or the second background region **50** descend to become sinkers (not shown) or depressed regions **54** and **42** in the second background region **50** or first background region **38**, respectively. In the transition region **62**, ends or beginning sections of the floats **60** from different background texture regions **38** and **50** overlap, creating a texture comprising adjacent floats **60** rather than the first or second background textures **39** and **51** which have alternating floats **60** and first or second depressed regions **42** and **54**, respectively. Thus, the transition region **62** provides a visually distinctive interruption to the first and second background textures **39** and **51** of the first and second background regions **38** and **50**, respectively, and form a substantially continuous transition region to provide a macroscopic, visually distinctive curvilinear decorative element that extends in directions other than solely the machine direction orientation of the floats **60**. In **Figure 1A**, the transition region **62** forms a curved diamond pattern.

[0047] The overall visual effect created by a repeating unit cell comprising the curvilinear transition region **62** of **Figure 1A** is shown in **Figure 1B**, which depicts several continuous transition regions **62** forming a repeating wedding ring pattern of curvilinear decorative elements.

[0048] **Figure 2** depicts a portion of a woven sculpted fabric **30** made according to the present invention. In this portion, the three shutes **45a**, **45b**, and **45c** are interwoven with the six warps **44a - 44f**. A transition region **62** separates a first background region **38** from a second background region **50**. The first background region **38** has first elevated strands **41a**, **41b**, and **41c** which define the first elevated regions **40a**, **40b**, and **40c**, and the first depressed strands **43a**, **43b**, and **43c** which define the first depressed regions **42** (only one of which is labeled). The alternation between the first elevated regions **40a**, **40b**, and **40c** and the first depressed regions **42** creates a first background texture **39** in the first background region **38**.

[0049] Likewise, the second background region **50** has second elevated strands **53a**, **53b**, and **53c** which define the second elevated regions **52a**, **52b**, and **52c**, and the second depressed strands **55a**, **55b**, and **55c** which define the second depressed regions **54** (only one of which

is labeled).

[0050] The alternation of second elevated regions **52a**, **52b**, and **52c** with the second depressed regions **54** creates a second background texture **51** in the second background region **50**. The warps **44a**, **44b**, and **44c** forming the first elevated regions **40a**, **40b**, and **40c** in the first background region **38** become the second depressed regions **54** (second depressed strands **55a**, **55b**, and **55c**) in the second background region **50**, and visa versa.

[0051] In general, the warps **44** in either of the first and second background region **38** and **50** alternate in the cross-machine direction between being floats **60** and sinkers **61**, providing a background texture **39** or **51** dominated by machine direction elongated features which become inverted (floats **60** become sinkers **61** and visa versa) after passing through the transition zone **62**.

[0052] Three crossover zones **65a**, **65b**, and **65c** occur in the transition region **62** where a first elevated strand **41a**, **41b**, or **41c** descends below a shute **45a**, **45b**, or **45c** in the vicinity where a second elevated strand **53a**, **53b**, or **53c** also descends below a shute **45a**, **45b**, or **45c**. In the crossover zone **65a**, the warps **44a** and **44d** both descend from their status as floats **60** in the first and second background regions **38** and **50**, respectively, to become sinkers **61**, with the descent occurring between the shutes **45b** and **45c**.

[0053] The crossover zone **65c** differs from the crossover zones **65a** and **65b** in that the two adjacent warps **44c** and **44f** descend on opposite sides of a single shute **45a**. The tension in the warps **44c** and **44f** can act in the crossover zone **65c** to bend the shute **45a** downward more than normally encountered in the first and second background regions **38** and **50**, resulting in a depression in the woven sculpted fabric **30** that can result in increased depth of molding in the vicinity of the crossover zone **65c**. Overall, the various crossover zones **65a**, **65b**, and **65c** in the transition region **62** provide increased molding depth in the woven sculpted fabric **30** that can impart visually distinctive curvilinear decorative elements to an absorbent tissue product **27** molded thereon, with the visually distinct nature of the curvilinear decorative elements being achieved by means of the interruption in the texture dominated by the MD-oriented floats **60** between two adjacent background regions **38** and **50** and optionally by the increased molding depth in the transition region **62** due to pockets or depressions in the woven sculpted fabric **30** created by the crossover zones **65a**, **65b**, and **65c**.

[0054] The first and second depressed strands **43** and **55** can be classified as sinkers **61**, while the first and second elevated strands **41** and **53** can be classified as floats **60**.

[0055] The shutes **45** depicted in **Figure 2** represent the topmost layer of CD shutes **33** of the woven sculpted fabric **30**, which can be part of a base layer **31** of the woven sculpted fabric **30**. A base layer **31** can be a load-bearing layer. The base layer **31** can also comprise multiple groups of interwoven warps **44** and shutes **45** or

nonwoven layers (not shown), metallic elements or bands, foam elements, extruded polymeric elements, photocured resin elements, sintered particles, and the like.

[0056] **Figure 3** is a cross-sectional view of a portion of a woven sculpted fabric **30** showing a crossover region **65** similar to that of crossover region **65c** in **Figure 2**. Five consecutive shutes **45a - 45e** and two adjacent warps **44a** and **44b** are shown. The two warps **44a** and **44b** serve as a first elevated strand **41** and second elevated strand **53**, respectively, in a first background region **38** and a second background region **50**, respectively, where the warps **44a** and **44b** are floats **60** defining a first elevated region **40** and a second elevated region **52**, respectively. After passing through the transition region **62** and crossing over the shute **45c** in a crossover region **65**, the two warps **44a** and **44b** each become sinkers **61** as the two warps **44a** and **44b** extend into the second background region **50** and the first background region **38**, respectively.

[0057] In the crossover zone **65**, the two adjacent warps **44a** and **44b** descend on opposite sides of a single shute **45c**. The tension in the warps **44c** and **44f** can act in the crossover zone **65** to bend the shute **45c** downward relative to the neighboring shutes **45a**, **45b**, **45d**, and **45e**, and particularly relative to the adjacent shutes **45b** and **45d**, resulting in a depression in the woven sculpted fabric **30** having a depression depth **D** relative to the maximum plane difference of the float **60** portions of the warps **44a** and **44b** in the adjacent first and second background regions **38** and **50**, respectively, that can result in increased depth of molding in the vicinity of the crossover zone **65**.

[0058] The maximum plane difference of the floats **60** may be at least about 30% of the width of at least one of the floats **60**. In other embodiments, the maximum plane difference of the floats **60** may be at least about 70%, more specifically at least about 90%. The maximum plane difference of the floats **60** may be at least about 0.12 millimeter (mm). In other embodiments, the maximum plane difference of the floats **60** may be at least about 0.25 mm, more specifically at least about 0.37 mm, and more specifically at least about 0.63 mm.

[0059] **Figure 4** depicts another cross-sectional view of a portion of a woven sculpted fabric **30** showing a crossover region **65**. Seven consecutive shutes **45a - 45g** and two adjacent warps **44a** and **44b** are shown.

[0060] The two warps **44a** and **44b** serve as a first elevated strand **41** and second elevated strand **53**, respectively, in a first background region **38** and second background region **50**, respectively, where the warps **44a** and **44b** are floats **60** defining a first elevated region **40** and second elevated region **52**, respectively. The transition region **62** spans three shutes **45c**, **45d** and **45e**. Proceeding from right to left, the first elevated strand **41** enters the transition region **62** between the shutes **45f** and **45e**, descending from its status as a float **60** in first background region **38** as it passes beneath the float **45e**.

It then passes over the shute **45d** and then descends below the shute **45c**, continuing on into the second background region **50** where it becomes a sinker **61**. The second elevated strand **53** is a mirror image of the first elevated strand **41** (reflected about an imaginary vertical axis, not shown, passing through the center of the shute **45d**) in the portion of the woven sculpted fabric **30** depicted in **Figure 4**. Thus, the second elevated strand **53** enters the transition region **62** between the shutes **45b** and **45c**, passes over the shute **45d**, and then descends beneath the shute **45e** to become a sinker **61** in the first background region **38**. The first elevated strand **41** and the second elevated strand **53** cross over each other in a crossover region **65** above the shute **45d**, which may be deflected downward by tension in the warps **44a** and **44b**.

[0061] Also depicted is the topmost layer of CD shutes **33** of the woven sculpted fabric **30**, which can define an upper plane **32** of the topmost layer of CD shutes **33** when the fabric **30** is resting on a substantially flat surface. Not all shutes **45** in the topmost layer of CD shutes **33** sit at the same height; the uppermost shutes **45** of the topmost layer of CD shutes **33** determine the elevation of the upper plane **32** of the topmost layer of CD shutes **33**. The difference in elevation between the upper plane **32** of the topmost layer of CD shutes **33** and the highest portion of a float **60** is the "Upper Plane Difference," as used herein, which can be 30% or greater of the diameter of the float **60**, or can be about 0.1 mm or greater; about 0.2 mm or greater; or, about 0.3 mm or greater.

[0062] **Figure 5** depicts another cross-sectional view of a portion of a woven sculpted fabric **30** showing a transition region **62** with a crossover region **65**; the transition region **62** being between a first background region **38** and a second background region **50**. Eleven consecutive shutes **45a - 45k** and two adjacent warps **44a** and **44b** are shown. The configuration is similar to that of **Figure 4** except that the warp **44a** which forms the first elevated strand **41** is shifted to the right by about twice the typical shute spacing **S** such that the warp **44a** no longer passes over the same shute (**45e** in **Figure 5**, analogous to **45d** in **Figure 4**) as the warp **44b** that forms the second elevated strand **53** before descending to become a sinker **61**. Rather, the warp **44a** is shifted such that the warp **44a** passes over the shute **45g** before descending to become a sinker **61**. Both the warps **44a** and **44b** pass below the shute **45f** in the crossover region **65**.

[0063] **Figure 6** depicts yet another cross-sectional view of a portion of a woven sculpted fabric **30** showing a transition region **62** with a crossover region **65**. Seven consecutive shutes **45a - 45g** and two adjacent warps **44a** and **44b** are shown. The crossover region **65** is similar to the crossover regions **65a** and **65b** of **Figure 2**. Both warps **44a** and **44b** descend below a common shute **45d** in the transition region **62**, becoming the sinkers **61**.

[0064] **Figure 7** will be discussed hereinafter with respect to the analysis of the profile lines.

[0065] **Figure 8** is a cross-sectional view depicting an-

other embodiment of a woven sculpted fabric 30. Here the two adjacent warps 44a and 44b are shown interwoven with the five consecutive shutes 45a - 45e. As the warp 44a enters the transition region 62 from the first background region 38 where the warp 44a is a float 60, the warp 44a descends below the shute 45c in the transition region 62 and then rises again as it leaves the transition region 62 to become a float 60 in the second background region 50. Likewise, the warp 44b is a sinker 61 in the second background region 50, rises in the transition region 62 to pass above the shute 45c, then descends near the end of the transition region 62 to become a sinker 61 in the first background region 38. In the transition region 62, there are two crossover regions 65 for the two adjacent warps 44a and 44b. One can recognize that the first and second background textures 39 and 51 (not shown) formed by successive pairs of warps 44 (e.g., adjacent floats 60 and sinkers 61, such as the warp 44a and the warp 44b) would be interrupted at the transition region 62, and if multiple transition regions 62 were positioned to form a substantially continuous transition region 62 across a plurality of adjacent warps 44 (e.g., 8 or more adjacent warps 44), a curvilinear decorative element could be formed from the interruption in the background textures 39 and 51 of the background regions 38 and 50, respectively, imparting a visually distinctive texture to the wet tissue web 15 of an absorbent tissue product *27 molded on the woven sculpted fabric 30.

[0066] The sheets of the absorbent tissue products 27 (shown in Figures 29 and 30) of the present invention have two or more distinct textures. There may be at least one background texture 39 or 51 (also referred to as local texture) created by elevated warps 44, shutes 45, or other elevated elements in a woven sculpted fabric 30. For example, a first background region 38 of such a woven sculpted fabric 30 may have a first background texture 39 corresponding to a series of elevated and depressed regions 40 and 42 having a characteristic depth. The characteristic depth can be the elevation difference between the elevated and depressed strands 41 and 43 that define the first background texture 39, or the elevation difference between raised elements, such as the elevated warps 44 and shutes 45, and the upper plane 32 which sits on the topmost layer of CD shutes 33 of the woven sculpted fabric 30 (shown in Figure 4). The shutes 45 can be part of a base layer 31 of the woven sculpted fabric 30, which can be a load-bearing base layer 31 (the base layer in the woven sculpted fabric 30 of Figure 2 is depicted as the layer 31 of the shutes 45, but can comprise additional woven or interwoven layers, or can comprise nonwoven layers or composite materials)..

[0067] Figure 9 is a computer generated graphic of a woven sculpted fabric 30 according to the present invention depicting the shutes 45 and only the relatively elevated portions of the warps 44 on a black background for clarity. The most elevated portions of the warps 44, namely, the floats 60 that pass over two or more of the shutes 45, are depicted in white. Short intermediate

knuckles 59, which are portions of the warps 44 that pass over a single shute 45, are more tightly pulled into the woven sculpted fabric 30 and protrude relatively less. To indicate the relatively lesser height of the intermediate knuckles 59, the intermediate knuckles 59 are depicted in gray, as are the shutes 45. In the center of the graphic lies a first background region 38 having first elevated regions 40 (machine direction floats 60) separated from one another by the first depressed regions 41 comprising intermediate knuckles 59, shutes 45, and sinkers 61 (not shown). As a warp 44 having a first elevated region 40 passes through the transition region 62a and enters the second background region 50, it descends into the woven sculpted fabric 30 and at least part of the warp 44 in the second background region 50 becomes a second depressed region 53. Likewise, the warps 44 that form a second elevated region 52 in the second background region 50 become depressed after passing through the transition region 62a such that at least part of such warps 44 now form the first depressed regions 41.

[0068] A second transition region 62b is shown in Figure 9, although in this case it is part of repeating elements substantially identical to portions of the first transition region 62a. In other embodiments, the woven sculpted fabric 30 can have a complex pattern such that a basic repeating unit has a plurality of background regions (e.g., three or more distinct regions) and a plurality of transition regions 62.

30 Tissue Description

[0069] A second background region 50 of the woven sculpted fabric 30 may have a second background texture 51 with a similar or different characteristic depth compared to the first background texture 39 of the first background region 38. The first and second background regions 38 and 50 are separated by a transition region 62 which forms a visually noticeable border 63 between the first and second background regions 38 and 50 and which provides a surface structure molding the wet tissue web 15 to a different depth or pattern than is possible in the first and second background regions 38 and 50. The transition region 62 created is preferably oriented at an angle to the warp or shute directions. Thus, a wet tissue web 15 molded against the woven sculpted fabric 62 is provided with a distinctive texture corresponding to the first and/or second background textures 39 and/or 51 and substantially continuous curvilinear decorative elements corresponding to the transition region 62, which can stand out from the surrounding first and second background texture regions 39 and 51 of the first and second background regions 38 and 50 of the wet tissue web 15 by virtue of having a different elevation (higher or lower as well as equal) or a visually distinctive area of interruption between the first and second background texture regions 39 and 51 of the first and second background regions 38 and 50, respectively.

[0070] In one embodiment, the transition region 62 pro-

vides a surface structure wherein the wet tissue web **15** is molded to a greater depth than is possible in the first and second background regions **38** and **50**. Thus, a wet tissue web **15** molded against the woven sculpted fabric **30** is provided with greater indentation (higher surface depth) in the transition region **62** than in the first and second background regions **38** and **50**.

[0071] In other embodiments, the transition region **62** can have a surface depth that is substantially the same as the surface depth of either the first or second background regions **38** and **50**, or that is between the surface depths of the first and second background regions **38** and **50** (an intermediate surface depth), or that is within plus or minus 50% of the average surface depth of the first and second background regions **38** and **50**, or more specifically within plus or minus 20% of the average surface depth of the first and second background regions **38** and **50**.

[0072] When the surface depth of the transition region **62** is not greater than that of the first and second background regions **38** and **50**, the curvilinear decorative elements corresponding to the transition region **62** imparted to the wet tissue web **15** by molding against the transition region **62** is at least partially due to the interruption in the curvilinear decorative elements provided by the first and second background regions **38** and **50** which creates a visible border **63** or marking extending along the transition region **62**. The curvilinear decorative elements imparted to the wet tissue web **15** in the transition region **62** may simply be the result of a distinctive texture interrupting the first and second background regions **38** and **50**.

[0073] In one embodiment of the present invention, the first and second background regions **38** and **50** both have substantially parallel woven first and second elevated strands **41** and **53**, respectively, with a dominant direction (e.g., machine direction, cross-machine direction, or an angle therebetween), wherein first background texture **39** in the first background region **38** is offset from the second background texture **51** in the second background region **50** such that as one moves horizontally (parallel to the plane of the woven sculpted fabric **30**) along a woven first elevated strand **41** in the first background region **38** toward the transition region **62** and continues in a straight line into the second background region **50**, a second depressed region **54** rather than a second elevated strand **58** is encountered in the second background region **50**.

[0074] Likewise, a first depressed region **42** that approaches the transition region **62** in the first background region **38** becomes a second elevated strand **53** in the second background region **50**. When the woven sculpted fabric **30** is comprised of woven warps **44** (machine direction strands) and shutes **45** (cross-machine direction strands), the first and second elevated regions **40** and **52** are floats **60** rising above the topmost layer of CD shutes **33** of the woven sculpted fabric **30** and crossing over a plurality of roughly orthogonal strands before de-

scending into the topmost layer of CD shutes **33** of the woven sculpted fabric **30** again.

[0075] For example, a warp **44** rising above the topmost layer of CD shutes **33** of the woven sculpted fabric **30** can pass over 4 or more shutes **45** before descending into the woven sculpted fabric **30** again, such as at least any of the following number of shutes **45**: 5, 6, 7, 8, 9, 10, 15, 20, and 30. While the warp **44** in question is above the topmost layer of CD shutes **33**, the immediately adjacent warps **44** are generally lower, passing into the topmost layer of CD shutes **33**. As the warp **44** in question then sinks into the topmost layer of CD shutes **33**, the adjacent warps **44** rise and extend over a plurality of shutes **45**. Generally, over much of the woven sculpted fabric **30**, four adjacent warps **44** arbitrarily numbered in order 1, 2, 3, and 4, can have warps **44** 1 and 3 rise above the topmost layer of CD shutes **33** to descend below the topmost layer of CD shutes **33** after a distance, at which point warps **44** 2 and 4 are initially primarily below the surface of the warps **44** in the topmost layer of CD shutes **33** but rise in the region where warps **44** 1 and 3 descend.

[0076] In another embodiment of the present invention, the first and second background regions **38** and **50** both have substantially parallel woven first and second elevated strands **41** and **53** with a dominant direction (e.g., machine direction, cross-machine direction, or an angle therebetween), wherein first background texture **39** in the first background region **38** is offset from the second background texture **51** in the second background region **50** such that as one moves horizontally (parallel to the plane of the woven sculpted fabric **30**) along a woven first elevated strand **41** in the first background region **38** toward the transition region **62** and continues in a straight line into the second background region **50**, a woven second elevated strand **53** rather than a second depressed region **54** is encountered in the second background region **50**. Likewise, a first depressed region **42** that approaches the transition region **62** in the first background region **38** becomes a second depressed region **54** in the second background region **50**.

[0077] In another embodiment of the present invention, the woven sculpted fabric **30** is a woven fabric having a tissue contacting surface including at least two groups of strands, a first group of strands **46** extending in a first direction, and a second group of strands **58** extending in a second direction which can be substantially orthogonal to the first direction, wherein the first group of strands **46** provides elevated floats **60** defining a three-dimensional fabric surface comprising:

- a) a first background region **38** comprising a plurality of substantially parallel first elevated strands **41** separated by substantially parallel first depressed strands **43**, wherein each first depressed strand **43** is surrounded by an adjacent first elevated strand **41** on each side, and each first elevated strand **41** is surrounded by an adjacent first depressed strand **43** on each side;

b) a second background region **50** comprising a plurality of substantially parallel second elevated strands **53** separated by substantially parallel second depressed strands **55**, wherein each second depressed strand **55** is surrounded by an adjacent second elevated strand **53** on each side, and each second elevated strand **53** is surrounded by an adjacent second depressed strand **55** on each side; and,
 c) a transition region **62** between the first and second background regions **38** and **50**, wherein the first and second elevated strands **41** and **53** of both the first and second background regions **38** and **50** descend to become, respectively, the first and second depressed strands **43** and **55** of the second and first background regions **38** and **50**.

In the transition region **62**, the first group of strands **46** may overlap with a number of strands in the second group of strands **58**, such as any of the following: 1, 2, 3, 4, 5, 10, two or more, two or less, and three or less.

[0078] Each pair of first elevated floats **41** is separated by a distance of at least about 0.3 mm. In other embodiments, each pair of first elevated floats **41** is separated by a distance ranging between about 0.3 mm to about 25 mm, more specifically between about 0.3 mm to about 8 mm, more specifically between about 0.3 mm to about 3 mm, more specifically between about 0.3 mm to about 1 mm, more specifically between about 0.8 mm to about 1 mm. Each pair of second elevated floats **53** is separated by a distance of at least about 0.3 mm. In other embodiments, each pair of second elevated floats **53** is separated by a distance ranging between about 0.3 mm to about 25 mm, more specifically between about 0.3 mm to about 8 mm, more specifically between about 0.3 mm to about 3 mm, more specifically between about 0.3 mm to about 1 mm, more specifically between about 0.8 mm to about 1 mm.

[0079] The resulting surface topography of the dried tissue web **23** may comprise a primary pattern **64** having a regular repeating unit cell that can be a parallelogram with sides between 2 and 180 mm in length. For wetlaid materials, these three-dimensional basesheet structures can be created by molding the wet tissue web **15** against the woven sculpted fabrics **30** of the present invention, typically with a pneumatic pressure differential, followed by drying. In this manner, the three-dimensional structure of the dried tissue web **23** is more likely to be retained upon wetting of the dried tissue web **23**, helping to provide high wet resiliency.

[0080] In addition to the regular geometrical patterns (resulting from the first and second background texture regions **39** and **51**, and the curvilinear decorative elements of the primary pattern **64**, imparted by the woven sculpted fabrics **30** and other typical fabrics used in creating a dried tissue web **23**, additional fine structure, with an in-plane length scale less than about 1 mm, can be present in the dried tissue web **23**. Such a fine structure may stem from microfolds created during differential ve-

locity transfer of the wet tissue web **15** from one fabric or wire to another fabric or wire prior to drying. Some of the absorbent tissue products **27** of the present invention, for example, appear to have a fine structure with a fine surface depth of 0.1 mm or greater, and sometimes 0.2 mm or greater, when height profiles are measured using a commercial moiré interferometer system. These fine peaks have a typical half-width less than 1 mm. The fine structure from differential velocity transfer and other treatments may be useful in providing additional softness, flexibility, and bulk. Measurement of the fine surface structures and the geometrical patterns is described below.

15 CADEYES MEASUREMENTS

[0081] One measure of the degree of molding created in a wet tissue web **15** using the woven sculpted fabrics **30** of the present invention involves the concept of optically measured surface depth. As used herein, "surface depth" refers to the characteristic height of peaks relative to surrounding valleys in a portion of a structure such as a wet tissue web **15** or putty impression of a woven sculpted fabric **30**. In many embodiments of the present invention, topographical measurements along a particular line will reveal many valleys having a relatively uniform elevation, with peaks of different heights corresponding to the first and second background texture regions **39** and **51** and a more prominent primary pattern **64**. The characteristic elevation relative to a baseline defined by surrounding valleys is the surface depth of a particular portion of the structure being measured. For example, the surface depth of a first or second background texture regions **39** or **51** of a wet tissue web **15** may be 0.4 mm or less, while the surface depth of the primary pattern **66** may be 0.5 mm or greater, allowing the primary pattern **64** to stand out from the first or second background texture regions **39** or **51**.

[0082] The wet tissue webs **15** created in the present invention possess three-dimensional structures and can have a Surface Depth for the first or second background texture regions **39** or **51** and/or primary pattern **64** of about 0.15 mm. or greater, more specifically about 0.3 mm. or greater, still more specifically about 0.4 mm. or greater, still more specifically about 0.5 mm. or greater, and most specifically from about 0.4 to about 0.8 mm. The primary pattern **64** may have a surface depth that is greater than the surface depth of the first or second background texture regions **39** or **51** by at least about 10%, more specifically at least about 25%, more specifically still at least about 50%, and most specifically at least about 80%, with an exemplary range of from about 30% to about 100%. Obviously, elevated molded structures on one side of a wet tissue web **15** can correspond to depressed molded structures on the opposite of the wet tissue web **15**. The side of the wet tissue web **15** giving the highest Surface Depth for the primary pattern **64** generally is the side that should be measured.

[0083] A suitable method for measurement of Surface Depth is moiré interferometry, which permits accurate measurement without deformation of the surface of the wet tissue webs **15**. For reference to the wet tissue webs **15** of the present invention, the surface topography of the wet tissue webs **15** should be measured using a computer-controlled white-light field-shifted moiré interferometer with about a 38 mm field of view. The principles of a useful implementation of such a system are described in Bieman et al. (L. Bieman, K. Harding, and A. Boehnlein, "Absolute Measurement Using Field-Shifted Moiré," SPIE Optical Conference Proceedings, Vol. 1614, pp. 259-264, 1991). A suitable commercial instrument for moiré interferometry is the CADEYES® interferometer produced by Integral Vision (Farmington Hills, Michigan), constructed for a 38-mm field-of-view (a field of view within the range of 37 to 39.5 mm is adequate). The CADEYES® system uses white light which is projected through a grid to project fine black lines onto the sample surface. The surface is viewed through a similar grid, creating moiré fringes that are viewed by a CCD camera. Suitable lenses and a stepper motor adjust the optical configuration for field shifting (a technique described below). A video processor sends captured fringe images to a PC computer for processing, allowing details of surface height to be back-calculated from the fringe patterns viewed by the video camera.

[0084] In the CADEYES moiré interferometry system, each pixel in the CCD video image is said to belong to a moiré fringe that is associated with a particular height range. The method of field-shifting, as described by Bieman et al. (L. Bieman, K. Harding, and A. Boehnlein, "Absolute Measurement Using Field-Shifted Moiré," SPIE Optical Conference Proceedings, Vol. 1614, pp. 259-264, 1991) and as originally patented by Boehnlein (U.S. Patent No. 5,069,548, herein incorporated by reference), is used to identify the fringe number for each point in the video image (indicating which fringe a point belongs). The fringe number is needed to determine the absolute height at the measurement point relative to a reference plane. A field-shifting technique (sometimes termed phase-shifting in the art) is also used for sub-fringe analysis (accurate determination of the height of the measurement point within the height range occupied by its fringe). These field-shifting methods coupled with a camera-based interferometry approach allows accurate and rapid absolute height measurement, permitting measurement to be made in spite of possible height discontinuities in the surface. The technique allows absolute height of each of the roughly 250,000 discrete points (pixels) on the sample surface to be obtained, if suitable optics, video hardware, data acquisition equipment, and software are used that incorporates the principles of moiré interferometry with field-shifting. Each point measured has a resolution of approximately 1.5 microns in its height measurement.

[0085] The computerized interferometer system is used to acquire topographical data and then to generate

a grayscale image of the topographical data, said image to be hereinafter called "the height map". The height map is displayed on a computer monitor, typically in 256 shades of gray and is quantitatively based on the topographical data obtained for the sample being measured. The resulting height map for the 38-mm square measurement area should contain approximately 250,000 data points corresponding to approximately 500 pixels in both the horizontal and vertical directions of the displayed height map. The pixel dimensions of the height map are based on a 512 x 512 CCD camera which provides images of moiré patterns on the sample which can be analyzed by computer software. Each pixel in the height map represents a height measurement at the corresponding x- and y-location on the sample. In the recommended system, each pixel has a width of approximately 70 microns, i.e. represents a region on the sample surface about 70 microns long in both orthogonal in-plane directions). This level of resolution prevents single fibers projecting above the surface from having a significant effect on the surface height measurement. The z-direction height measurement must have a nominal accuracy of less than 2 microns and a z-direction range of at least 1.5 mm. (For further background on the measurement method, see the CADEYES Product Guide, Integral Vision, Farmington Hills, MI, 1994, or other CADEYES manuals and publications of Integral Vision, formerly known as Medar, Inc.).

[0086] The CADEYES system can measure up to 8 moiré fringes, with each fringe being divided into 256 depth counts (sub-fringe height increments, the smallest resolvable height difference). There will be 2048 height counts over the measurement range. This determines the total z-direction range, which is approximately 3 mm in the 38-mm field-of-view instrument. If the height variation in the field of view covers more than eight fringes, a wrap-around effect occurs, in which the ninth fringe is labeled as if it were the first fringe and the tenth fringe is labeled as the second, etc. In other words, the measured height will be shifted by 2048 depth counts. Accurate measurement is limited to the main field of 8 fringes.

[0087] The moiré interferometer system, once installed and factory calibrated to provide the accuracy and z-direction range stated above, can provide accurate topographical data for materials such as paper towels. (Those skilled in the art may confirm the accuracy of factory calibration by performing measurements on surfaces with known dimensions). Tests are performed in a room under Tappi conditions (23°C, 50% relative humidity). The sample must be placed flat on a surface lying aligned or nearly aligned with the measurement plane of the instrument and should be at such a height that both the lowest and highest regions of interest are within the measurement region of the instrument.

[0088] Once properly placed, data acquisition is initiated using Integral Visions's PC software and a height map of 250,000 data points is acquired and displayed, typically within 30 seconds from the time data acquisition

was initiated. (Using the CADEYES® system, the "contrast threshold level" for noise rejection is set to 1, providing some noise rejection without excessive rejection of data points). Data reduction and display are achieved using CADEYES® software for PCs, which incorporates a customizable interface based on Microsoft Visual Basic Professional for Windows (version 3.0). The Visual Basic interface allows users to add custom analysis tools.

[0089] The height map of the topographical data can then be used by those skilled in the art to identify characteristic unit cell structures (in the case of structures created by fabric patterns; these are typically parallelograms arranged like tiles to cover a larger two-dimensional area) and to measure the typical peak to valley depth of such structures. A simple method of doing this is to extract two-dimensional height profiles from lines drawn on the topographical height map which pass through the highest and lowest areas of the unit cells. These height profiles can then be analyzed for the peak to valley distance, if the profiles are taken from a sheet or portion of the sheet that was lying relatively flat when measured. To eliminate the effect of occasional optical noise and possible outliers, the highest 10% and the lowest 10% of the profile should be excluded, and the height range of the remaining points is taken as the surface depth. Technically, the procedure requires calculating the variable which we term "P10," defined at the height difference between the 10% and 90% material lines, with the concept of material lines being well known in the art, as explained by L. Mummery, in *Surface Texture Analysis: The Handbook*, Hommelwerke GmbH, Mühlhausen, Germany, 1990. In this approach, which will be illustrated with respect to **FIGURE 7**, the surface **70** is viewed as a transition from air **71** to material **72**. For a given profile **73**, taken from a flat-lying sheet, the greatest height at which the surface begins - the height of the highest peak - is the elevation of the "0% reference line" **74** or the "0% material line," meaning that 0% of the length of the horizontal line at that height is occupied by material **72**. Along the horizontal line passing through the lowest point of the profile **73**, 100% of the line is occupied by material **72**, making that line the "100% material line" **75**. In between the 0% and 100% material lines **74** and **75** (between the maximum and minimum points of the profile), the fraction of horizontal line length occupied by material **72** will increase monotonically as the line elevation is decreased. The material ratio curve **76** gives the relationship between material fraction along a horizontal line passing through the profile **73** and the height of the line. The material ratio curve **76** is also the cumulative height distribution of a profile **73**. (A more accurate term might be "material fraction curve").

[0090] Once the material ratio curve **76** is established, one can use it to define a characteristic peak height of the profile **73**. The P10 "typical peak-to-valley height" parameter is defined as the difference **77** between the heights of the 10% material line **78** and the 90% material line **79**. This parameter is relatively robust in that outliers

or unusual excursions from the typical profile structure have little influence on the P10 height. The units of P10 are mm. The Overall Surface Depth of a material **72** is reported as the P10 surface depth value for profile lines encompassing the height extremes of the typical unit cell of that surface **70**. "Fine surface depth" is the P10 value for a profile **73** taken along a plateau region of the surface **70** which is relatively uniform in height relative to profiles **73** encompassing a maxima and minima of the unit cells. Unless otherwise specified, measurements are reported for the surface **70** that is the most textured side of the wet tissue webs **15** of the present invention, which is typically the side that was in contact with the through-drying fabric **19** when air flow is toward the through-dryer **21**.

Detailed Description of Figures

[0091] **FIGURE 10** shows a screen shot **66** of the CADEYES® software main window containing a height map **80** of a putty impression of the woven sculpted fabric **30** made in accordance with the present invention. The height map **80** was created with a 35-mm field of view optical head with the CADEYES® moiré interferometry system. The putty impression was made using 65 grams of coral-colored Dow Corning 3179 Dilatant Compound (believed to be the original "Silly Putty®" material) in a conditioned room at 23°C and 50% relative humidity. The Dilatant Compound was rendered more opaque for better results with moiré interferometry by the addition of 0.8 g of white solids applied by painting white Pentel® (Torrance, CA) Correction Pen fluid (purchased 1997) on portions of the putty, allowing the fluid to dry, and then blending the painted portions to uniformly disperse the white solids (believed to be primarily titanium dioxide) throughout the putty. This action was repeated approximately a dozen times until a mass increase of 0.8 grams was obtained. The putty was rolled into a flat, smooth 9-cm wide disk, about 0.7 cm thick, which was placed over the woven sculpted fabric **30**. A stiff, clear plastic block with dimensions 22 cm x 9 cm x 1.3 cm, having a mass of 408 g, was centered over the putty disk and a 3.73 kg brass cylinder of 6.3-cm diameter was placed on the plastic block, also centered over the putty disk, and allowed to reside on the block for 8 seconds to drive the putty into the woven sculpted fabric **30**. After 8 seconds, the brass cylinder and plastic block were removed, and the putty was gently lifted from the woven sculpted fabric **30**. The molded side of the putty was turned face up and placed under a 35-mm field-of-view optical head of the CADEYES® device for measurement.

[0092] In the height map **80** in **FIGURE 10**, the horizontal bands of dark and light areas correspond to elevated and depressed regions. In a first background region **38'**, there are first elevated regions **40'** and first depressed regions **42'** created by molding against the first depressed regions **42** and the first elevated regions **40**, respectively, in a first background region **38** of a woven

sculpted fabric **30** (not shown). In a second background region **50'**, there are second elevated regions **52'** and second depressed regions **54'** corresponding to the second depressed regions **52** and the second elevated regions **54** in a second background region **50** of a woven sculpted fabric **30** (not shown). Between the first background region **38'** and the second background region **50'** is a transition region **62'** which is elevated, corresponding to a depressed transition region **62** of a woven sculpted fabric **30** (not shown). The elevated curvilinear decorative elements forming a transition region **62'** on the molded surface define a repeating elevated primary pattern **64** in which the repeating unit can be described as a diamond with concave sides. The junctions of the opposing MD strands in the transition region **62** of a woven sculpted fabric **30** (not shown) form pockets or segments of different plane height which visually connect to form curvilinear decorative elements making aesthetically pleasing design highlights in materials molded thereon.

[0093] The height map **80** contains some optical noise distorting the image along the left border of the height map **80**, and occasional spikes from optical noise in other portions of the image. Nevertheless, the structure of the putty impression is clearly discernible. The profile display **81** below the height map **80** shows the topography in the form of a profile **82** taken along a vertical profile line **87**. The topographical features of the profile **82** include peaks and valleys corresponding to first and second elevated regions **40'** and **52'** (the peaks) and first and second depressed regions **42'** and **54'** (the valleys), respectively, and the elevated transition regions **62'** that form the repeating curvilinear primary pattern **64**.

[0094] **FIGURE 11** shows a screen shot **66** of the CADEYES® software main window containing a height map **80** of a dried tissue web **23** molded on a woven sculpted fabric **30**, using a process substantially the same as the one described in the **Example**. The height map **80** is for a zoomed-in region covering a single unit cell of the curvilinear primary pattern **64**. The face-up side of the dried tissue web **23** - i.e., the surface being measured - is the side that was remote from the woven sculpted fabric **30** during through air drying, termed the "air side" of the dried tissue web **23**, as opposed to the opposing "fabric side" (not shown) that was in contact with the woven sculpted fabric **30** during through drying. Here, through drying on the woven sculpted fabric **30** imparted a molded texture that resembles the inverse of the texture in **FIGURE 10**. Thus, in the first background region **38'**, there are first elevated regions **40'** and first depressed regions **42'** created by molding of the fabric side of the tissue against first elevated regions **40** and first depressed regions **42**, respectively, in a first background region **38** of a woven sculpted fabric **30** (not shown). In the second background region **50'**, there are second elevated regions **52'** and second depressed regions **54'** corresponding to second elevated regions **52** and second depressed regions **54** in a second background region **50** of a woven sculpted fabric **30** (not

shown). Between the first background region **38'** and the second background region **50'** is a transition region **62'** which is depressed on the side of the dried tissue web **23** measured (the air side), but elevated on the opposing side (the fabric side), corresponding to a depressed transition region **62** of a woven sculpted fabric **30** (not shown). The depressed curvilinear decorative elements forming the transition region **62'** on the molded surface of the dried tissue web **23** define a repeating elevated primary pattern **64** in which the repeating unit can be described as a diamond with concave sides. The junctions of the opposing MD strands in the transition region **62** of a woven sculpted fabric **30** (not shown) form pockets or segments of different plane height which visually connect to form curvilinear decorative elements making aesthetically pleasing design highlights in materials molded thereon. Thus, the depressed transition regions **62'** form a repeating curvilinear primary pattern **64**.

[0095] The profile **82** along a vertical profile line **87** on the height map **80** is shown in the profile display **81** below the height map **80**, in which two depressed transition regions **62'** can be seen in the midst of the otherwise regular peaks and valleys, wherein the peaks correspond to first and second elevated regions **40'** and **52'**, respectively, and the valleys correspond to first and second depressed regions **42'** and **54'**, respectively.

[0096] **FIGURE 12** depicts a section of the height map **80** of **FIGURE 10** further displaying a profile **82** along a vertical profile line **87** on the height map **80**. The profile **82** shown in a vertically oriented profile display **81** comprises peaks and valleys, wherein the peaks correspond to first and second elevated regions **40'** and **52'**, respectively, and the valleys correspond to first and second depressed regions **42'** and **54'**, respectively, with transition regions **62'** also visible as relatively elevated features. A characteristic height of the peaks away from the transition regions **62'** is about 0.54 mm, while the transition regions **62'** display higher and broader peaks, with heights of about 0.75 mm.

[0097] **FIGURE 13** shows a section of a height map **80** for the dried tissue web **23** throughdried on the woven sculpted fabric **30** used in **FIGURE 10**, but with the sculpted fabric face up of the dried tissue web **23** (the side that was in contact with the woven sculpted fabric **30** during through drying). The profile display **81** shows a profile **82** measured along the vertical profile line **87** drawn across the height map **80** corresponding to the cross-machine direction of the tissue web **23**. The profile **82** has peaks corresponding to first and second elevated regions **40'** and **52'**, respectively, and the valleys corresponding to first and second depressed regions **42'** and **54'**, respectively, with transition regions **62'** also visible as relatively elevated features. The profile **82** shows that the broad peaks in the transition region **62'** have a greater height than the peaks away from the transition region **62'**. Relative to the valleys (the first depressed regions **42'**) in the first background region **38**, the peaks of the transition region **62'** show a height of about 0.55 mm. In the first

background region **38'**, the peaks (the first elevated regions **40'**) have about half the height of the transition region **62'** (e.g., a height of about 0.25 mm).

[0098] FIGURE 14 shows a portion of the height map **80** of FIGURE 11 with an accompanying profile display **81** showing a profile **82** taken along the horizontal (machine direction) profile line **87** drawn on the height map **80**. The profile **82** extends along the second elevated regions **52'** outside of the first background region **38'** and along the first depressed region **42'** within the first background region **38'**. A height difference **Z** of about 0.5 mm is spanned from the higher portion of the second elevated region **52'** to the depressed transition region **62'**.

[0099] FIGURE 15 is similar to FIGURE 14 except that a different profile line **87** is used, resulting in a different displayed profile **82** in the profile display **81**. The profile line **87** runs substantially in the machine direction, passing along a first depressed region **42'** in the first background region **38'**, then passing through a transition region **62'** and then along a second elevated region **52'** in the second background region **50'**. A vertical height difference **Z** of about 0.42 mm is spanned from the second elevated region **52'** to the first depressed region **42'**. The transition region **62** is about 0.2 mm lower than the first depressed region **42'** on this view of the fabric side of a molded dried tissue web **23** that has been throughdried on a woven sculpted fabric **30** according to the present invention.

[0100] FIGURE 16 shows a height map **80** of a putty impression of another woven sculpted fabric **30** made in accordance to the present invention, with a profile display **81** showing a profile **82** measured along a profile line **87** that spans a first background region **38'** and a second background region **50'** with a transition region **62'** therebetween. Based on the profile **82**, the transition region **62'** differs from the first elevated region **40'** by over than 0.4 mm, and differs from the second depressed region **54'** by over 0.8 mm (the height **Z**). Here the transition region **62'** forms a curvilinear decorative element with arcuate sides that entirely bound a closed area, though a portion of the closed area is not shown. Such closed areas can have a maximum diameter (maximum length of a line that can fit within the closed boundary while in the plane of the woven sculpted fabric **30**) of any of the following: 5 mm or greater; 10 mm or greater; 25 mm or greater; 50 mm or greater; and, 180 mm or greater, with an exemplary range of from about 8 mm to about 75 mm.

[0101] FIGURE 17 shows a height map **80** of a putty impression of yet another woven sculpted fabric **30** made in accordance to the present invention, wherein the transition regions **62'** form parallel lines at an angle relative to the substantially unidirectional warps **44** of the woven sculpted fabric **30**. In the profile display **81**, a profile **82** is shown corresponding to the surface height along the profile line **87** is substantially oriented in the cross-machine direction. The profile line **87** passes over second elevated regions **52'** and second depressed regions **54'** in the second background region **50'**, then passes across

a transition region **62'** and then over first elevated regions **40'** and second depressed regions **42'**. Here each transition region **62'** is substantially straight and forms a long line parallel to other transition regions **62'**. In general, when a transition region **62'** defines a line, the line can be at any angle to the machine direction (direction of the warps **44**), such as an absolute angle of 20 degrees or more, more specifically from about 20 degrees to less than 90 degrees, most specifically from about 30 degree to about 65 degrees. The height difference **Z** between the most elevated portion of the transition region **62'** along the profile **82** and the first depressed region of the first background region **38** is about 0.6 mm.

[0102] FIGURE 18 shows a schematic of a composite sculpted fabric **100** comprising a base fabric **102** with raised elements **108** attached thereon. The raised elements **108** as shown are aligned substantially in the machine direction **120** (orthogonal to the cross-machine direction **118**) in the portion of the composite sculpted fabric **100** shown, though the raised elements **108** could be oriented in any direction and could be oriented in a plurality of directions. The raised elements **108** as depicted have a height **H**, a length **L**, and a width **W**. The height **H** can be greater than about 0.1 mm, such as from about 0.2 mm to about 5 mm, more specifically from about 0.3 mm to about 1.5 mm, and most specifically from about 0.3 mm to about 0.7 mm. The length **L** can be greater than 2 mm, such as about 3 mm or greater, or from about 4 mm to about 25 mm. The width **W** can be greater than about 0.1 mm such as from about 0.2 mm to about 2 mm, more specifically from about 0.3 mm to about 1 mm.

[0103] In a first background region **38**, the machine-direction oriented, elongated raised elements **108** act as floats **60** that serve as first elevated regions **40**, with first depressed regions **42** therebetween that reside substantially on the underlying base fabric **102**, which can be a woven fabric. In a second background region **50**, the raised elements **108** act as floats **60** that serve as second elevated regions **52**, with second depressed regions **54** therebetween that reside substantially on the underlying base fabric **102**.

[0104] A transition region **62** is formed when a first elevated region **40** from a first background region **38** of the composite sculpted fabric **100** has an end **122** in the vicinity of the beginning **124** of two adjacent second elevated regions **52** in a second background region **50** of the composite sculpted fabric **100**, with the end **122** disposed in the cross-machine direction **118** at a position intermediate to the respective cross-machine direction locations of the two adjacent second elevated regions **52**, wherein the end **122** of raised elements **108** (either a first elevated region **40** or second elevated region **52**) refers to the termination of the raised element **108** encountered while moving along the composite sculpted fabric **100** in the machine direction **120**, and the beginning **124** of a raised element **108** refers to the initial portion of the raised element **108** encountered while moving along the composite sculpted fabric **100** in the same di-

rection. Were the raised elements **108** oriented in another direction, the direction of orientation for each raised element **108** is the direction one moves along in identifying ends **122** and beginnings **124** of raised elements **108** in order to identify their relationship in a consistent manner. Generally, features of the raised elements **108** can be successfully identified when either of the two possible directions (forward and reverse, for example) along the raised element **108** is defined as the positive direction for travel.

[0105] The transition region **62** separates the first and second background regions **38** and **50**. The shifting of the cross-machine directional locations of the raised elements **108** in the transition region **62** creates a break in the patterns of the first and second background regions **38** and **50**, contributing to the visual distinctiveness of the portion of the wet tissue web **15** molded against the transition region **62** of the composite sculpted fabric **100** relative to the portion of the wet tissue web **15** molded against the surrounding first and second background regions **38** and **50**. In the embodiment shown in **FIGURE 18**, the transition region **62** is also characterized by a gap width **G** which is the distance in the machine direction **120** (or, more generally, whatever direction the raised elements **108** are predominantly oriented in) between an end **122** of a raised element **108** in the first background region **38** and the nearest beginning **124** of a raised element **108** in the second background region **50**. The gap width **G** can vary in the transition region **62** or can be substantially constant. For positive gap widths **G** such as is shown in **FIGURE 18**, **G** can vary, by way of example, from about 0 to about 20 mm, such as from about 0.5 mm to about 8 mm, or from about 1 mm to about 3 mm.

[0106] A base fabric **102** can be woven or nonwoven, or a composite of woven and nonwoven elements or layers. The embodiment of the base fabric **102** depicted in **Figure 18** is woven, with the shutes **45** extending in the cross-machine direction **118** and the warps **44** in the machine direction **120**. The base fabric **102** can be woven according to any pattern known in the art and can comprise any materials known in the art. As with any woven strands for any fabrics of the present invention, the strands need not be circular in cross-section but can be elliptical, flattened, rectangular, cabled, oval, semi-oval, rectangular with rounded edges, trapezoidal, parallelograms, bi-lobal, multi-lobal, or can have capillary channels. The cross sectional shapes may vary along a raised element **108**; multiple raised elements with differing cross sectional shapes may be used on the composite sculpted fabric **100** as desired. Hollow filaments can also be used.

[0107] The raised elements **108** can be integral with the base fabric **102**. For example, a composite sculpted fabric **100** can be formed by photocuring of elevated resinous elements which encompass portions of the warps **44** and shutes **45** of the base fabric **102**. Photocuring methods can include UV curing, visible light curing, electron beam curing, gamma radiation curing, radiofrequency curing, microwave curing, infrared curing, or other

known curing methods involving application of radiation to cure a resin. Curing can also occur via chemical reaction without the need for added radiation as in the curing of an epoxy resin, extrusion of an autocuring polymer such as polyurethane mixture, thermal curing, solidifying of an applied hotmelt or molten thermoplastic, sintering of a powder in place on a fabric, and application of material to the base fabric **102** in a pattern by known rapid prototyping methods or methods of sculpting a fabric. Photocured resin and other polymeric forms of the raised elements **108** can be attached to a base fabric **102** according to the methods in any of the following patents: U.S. Patent No. 5,679,222, issued on October 21, 1997 to Rasch et al.; U.S. Patent No. 4,514,345, issued on April 30, 1985 to Johnson et al.; U.S. Patent No. 5,334,289, issued on August 2, 1994 to Trokhan et al.; U.S. Patent No. 4,528,239, issued on July 9, 1985 to Trokhan; U.S. Patent No. 4,637,859, issued on January 20, 1987 to Trokhan; commonly owned U.S. Patent No. 6,120,642, issued on September 19, 2000 to Lindsay and Burazin; and, commonly owned patent applications Serial Nos. 09/705,684 and 09/706,149, both filed on November 3, 2000 by Lindsay et al.; all of which are herein incorporated by reference to the extent they are not contradictory herewith.

[0108] U.S. Patent No. 6,120,642, issued on September 19, 2000 to Lindsay and Burazin, discloses methods of producing sculpted nonwoven throughdrying fabrics, and such methods can be applied in general to create composite sculpted fabrics **100** of the present invention. In one embodiment, such composite sculpted fabrics **100** comprise an upper porous nonwoven member and an underlying porous member supporting the upper porous member, wherein the upper porous nonwoven member comprises a nonwoven material (e.g., a fibrous nonwoven, an extruded polymeric network, or a foam-based material) that is substantially deformable. More specifically, the can have a High Pressure Compressive Compliance (hereinafter defined) greater than 0.05, more specifically greater than 0.1, and wherein the permeability of the wet molding substrate is sufficient to permit an air pressure differential across the wet molding substrate to effectively mold said web onto said upper porous nonwoven member to impart a three-dimensional structure to said web.

[0109] As used herein, "High Pressure Compressive Compliance" is a measure of the deformability of a substantially planar sample of the material having a basis weight above 50 gsm compressed by a weighted platen of 3-inches in diameter to impart mechanical loads of 0.2 psi and then 2.0 psi, measuring the thickness of the sample while under such compressive loads. Subtracting the ratio of thickness at 2.0 psi to thickness at 0.2 psi from 1 yields the High Pressure Compressive Compliance. In other word, High Pressure Compressive Compliance = $1 - (\text{thickness at 2.0 psi} / \text{thickness at 0.2 psi})$. The High Pressure Compressive Compliance can be greater than about 0.05, specifically greater than about 0.15, more

specifically greater than about 0.25, still more specifically greater than about 0.35, and most specifically between about 0.1 and about 0.5. In another embodiment, the High Pressure Compressive Compliance can be less than about 0.05, in cases where a less deformable composite sculpted fabric **100** is desired.

[0110] Other known methods can be used to create the composite sculpted fabrics **100** of the present invention, including laser drilling of a polymeric web to impart elevated and depressed regions, ablation, extrusion molding or other molding operations to impart a three-dimensional structure to a nonwoven material, stamping, and the like, as disclosed in commonly owned patent applications Serial Nos. 09/705,684 and 09/706,149, both filed on November 3, 2000 by Lindsay et al.; previously incorporated by reference.

[0111] **FIGURE 19** depicts another embodiment of a composite sculpted fabric **100** comprising a base fabric **102** with raised elements **108** attached thereon, similar to that of **FIGURE 18** but with raised elements **108** that taper to a low height H_2 relative to the minimum height H_1 of the raised element **108**. H_1 can be from about 0.1 mm to about 6 mm, such as from about 0.2 mm to about 5 mm, more specifically from about 0.25 mm to about 3 mm, and most specifically from about 0.5 mm to about 1.5 mm. The ratio of H_2 to H_1 can be from about 0.01 to about 0.99, such as from about 0.1 to about 0.9, more specifically from about 0.2 to about 0.8, more specifically still from about 0.3 to about 0.7, and most specifically from about 0.3 to about 0.5. The ratio of H_2 to H_1 can also be less than about 0.7, about 0.5, about 0.4, or about 0.3. Further, the gap width G , the distance between the beginning **124** and ends **122** of nearby raised elements **108** from adjacent first and second background regions **38** and **50**, is now negative, meaning that the end **122** of one raised element **108** (a first elevated region **40**) in the first background region **38** extends in machine direction **120** past the beginning **124** of the nearest raised element **108** (a second elevated region **52**) in the second background region **50** such that raised elements **108** overlap in the transition region **62**. Two gap widths G are shown: G_1 and G_2 at differing locations in the composite sculpted fabric **100**. Here the gap width G has nonpositive values, such as from about 0 to about -10 mm, or from about -0.5 mm to about -4 mm, or from about -0.5 mm to about -2 mm. However, a given composite sculpted fabric **100** may have portions of the transition region **62** that have both nonnegative and nonpositive (or positive and negative) values of G .

[0112] It is recognized that other topographical elements may be present on the surface of the composite sculpted fabric **100** as long as the ability of the raised elements **108** and the transition region **62** to create a visually distinctive molded wet tissue web **15** is not compromised. For example, the composite sculpted fabric **100** could further comprise a plurality of minor raised elements (not shown) such as ovals or lines having a height less than, for example, about 50% of the minimum height

H_1 of the raised elements **108**.

[0113] **FIGURES 20 - 22** are schematic diagram views of the raised elements **108** in a composite sculpted fabric **100** depicting alternate forms of the raised elements **108** according to the present invention. In each case, a set of first raised elements **108'** in a first background region **38** interacts with a set of second raised elements **108''** in a second background region **128** to define a transition region **62** between the first and second background regions **38** and **50**, wherein both the discontinuity or shift in the pattern across the transition region **62** as well as an optional change in surface topography along the transition region **62** contribute to a distinctive visual appearance in the wet tissue web **15** molded against the composite sculpted fabric **100**, wherein the loci of transition regions **62** define a visible pattern in the molded wet tissue web **15** (not shown). In **FIGURE 20**, the first and second raised elements **108'** and **108''** overlap slightly and define a nonlinear transition region **62** (i.e., there is a slight curve to it as depicted). Further, parallel, adjacent raised elements **108** in either a first or second background region **38** or **50**, are spaced apart in the cross-machine direction **118** by a distance S slightly greater than the width W of a first or second raised element **108'** or **108''** (e.g., the cross-machine direction spacing from centerline to centerline of the first and second raised elements **108'** and **108''** divided by the width W of the first and second raised elements **108'** and **108''** can be greater than about 1, such as from about 1.2 to about 5, or from about 1.3 to about 4, or from about 1.5 to about 3). In **FIGURE 21**, the spacing S is nearly the same as the width W (e.g., the ratio S/W can be less than about 1.2, such as about 1.1 or less or about 1.05 or less). Further, the overlapping first and second raised elements **108'** and **108''** in the transition region **62** results in a gap width of about $-2W$ or less (meaning that the ends **122** and beginnings **124** of the first and second raised elements **108'** and **108''** overlap by a distance of about twice or more the width W of the first and second raised elements **108'** and **108''**). In **FIGURE 22**, the tapered raised elements **108** are depicted which are otherwise similar to the raised elements **108** as shown in

FIGURE 20.

[0114] It will be recognized that the shapes and dimensions of the raised elements **108** need not be similar throughout the composite sculpted fabric **100**, but can differ from any of the first and second background region **38** or **50** to another or even within a first or second background region **38** or **50**. Thus, there may be a first background region **38** comprising cured resin first raised elements **108'** having a shape and dimensions (W , L , H , and S , for example) different from those of the second raised elements **108''** of the second background region **50**.

[0115] The raised elements **108** need not be straight, as generally depicted in the previous figures, but may be

curvilinear.

[0116] In **Figures 23** and **24**, a portion of the CADEYES height map **80** referred to in **Figure 17** was used to identify the approximate contour of elevated portions of the transition region **62'**. The original portion of the height map **80** is shown in **Figure 23**. The modified version is shown in **Figure 24**. The modified version was created by importing the original into the PhotoPlus 7@ graphics program for the PC by Serif, Inc. (Hudson, New Hampshire). The image was treated with the "Stretch" command to distribute the color histogram levels more fully across the spectrum. Then the most elevated portion of the transition region **62'** in the lower half of the image was selected by clicking with the color selection tool set to a tolerance value of **12**. The selected region of the transition region **62'** was then filled with white. The same procedure was applied to the transition region **62'** in the upper left hand corner of the image. The white portions of the transition region **62'** in effect show the shape of the contour encompassing the highest portions of the surface, and correspond roughly to the upper contours that could be imparted to a dried tissue web **23**. The elevated contours have a generally sinuous shape, with depresses islands corresponding to the floats **60** or knuckles of the woven sculpted fabric **30**.

[0117] **Figure 25** depicts a portion of a dried tissue web **23** having a continuous background texture **146** depicted as a rectilinear grid, though any pattern or texture could be used. The dried tissue web **23** further comprises a raised transition region **62'** which has a visually distinctive primary pattern **145**. In a local region **148** of the dried tissue web **23** that spans both sides of a portion of the transition region **62'**, two portions the background texture **146** define, at a local level, a first background region **38'** and a second background region **50'** separated by a transition region **62'** in the dried tissue web **23**. Thus, the first background region **38'** and the second background region **50'**, though separated by the transition region **62'**, are nevertheless contiguous outside the local region **148** of the dried tissue web **23**. In other embodiments, the transition region **62'** can define enclosed first and second background regions **38'** and **50'**, respectively, that are contiguous outside of a local region **148** or fully separated first and second background regions **38'** and **50'**, respectively, that are not contiguous.

[0118] **Figures 26a - 26e** show other embodiments for the arrangement of the warps **44** in the first background region **38** of a woven sculpted fabric **30** (though the embodiment shown could equally well be applied to a second background region **50**), taken in cross-sectional views looking into the machine direction. **Figure 26a** shows an embodiment related to those of **Figures 1a, 1b, and 2**, wherein each single float **60** is separated from the next single float **60** by a single sinker **61**. However, single strands are not the only way to form the first elevated regions **40** (which could equally well be depicted as second elevated regions **52**) or the first depressed regions **42** (which could equally well be depicted as sec-

ond depressed regions **54**). Rather, **Figures 26b - 26e** show embodiments in which at least one of the first elevated regions **40** or first depressed regions **42** comprises more than one warp **44**. **Figure 26b** shows single spaced apart single strand floats **60** forming the first elevated regions **40**, interspaced (with respect to a view from above the shute **45**) by double-strand sinkers **61** (or, equivalently, pairs of adjacent single-strand sinkers **61**) which define first depressed regions **42** between each first elevated region **40**. In **Figure 26c**, the first elevated regions **40** each comprise pairs of warps **44**, while the interspaced first depressed regions **42** likewise comprise pairs of warps **44** forming double-strand sinkers **61**. In **Figure 26d**, double-strand first elevated regions **40** are interspaced by triple-strand first depressed regions **42**. In **Figure 26e**, the single-, double-, and triple-strand groups form both the first elevated regions **40** and the first depressed regions **42**. Many other combinations are possible within the scope of the present invention. Thus, any machine-direction oriented elevated or depressed region in a woven sculpted fabric **30** can comprise a group of any practical number of warps **44**, such as any number from 1 to 10, and more specifically from 1 to 5. Such groups can comprise parallel monofilament strands or multifilament strands such as cabled filaments.

The Product

[0119] **FIGURE 28** is a photograph of a woven sculpted fabric **30** embodiment of the present invention. The decorative pattern repeats in a rectangular unit cell which is about 33 mm MD by 38 mm CD in size. The width of the floats **60** is about 0.70 mm. The adjacent elevated floats **60** are separated by a distance which averages about 0.89 mm.

[0120] In the woven sculpted fabric **30** shown in **FIGURE 28**, the plane difference varies in the MD and CD throughout the fabric unit cell. For a given float **60**, the plane difference tends to be minimal near transition regions **62** and maximal half way between two transition regions **62** in the MD. In general, plane difference is larger for a long sinker **61** between two long floats **60** than a short sinker **61** between two short floats **60**. This variation in plane difference contributes to the aesthetics of the overall decorative pattern.

[0121] In the woven sculpted fabric **30** shown in **FIGURE 28**, the separation distance between adjacent elevated floats **60** varies in the MD and CD throughout the fabric unit cell. This variation in separation distance between adjacent elevated floats **60** contributes to the aesthetics of the overall decorative pattern.

[0122] **FIGURES 29 and 30** shows the air side and the fabric side an absorbent tissue product **27** made in accordance with the present invention as described herein in the Example, depicting an interlocking circular primary pattern **64** made from the distinctive background textures **39** and **51** and curvilinear decorative elements on the dried tissue web **23** by a plurality of transition areas **62**

of throughdrying fabric **19**. The distinctive background textures **39** and **51** and curvilinear decorative elements, in addition to providing valuable consumer preferred aesthetics, also unexpectedly improve physical attributes of the absorbent tissue product **27**. The distinctive background textures **39** and **51** and curvilinear decorative elements in the dried tissue web **23** produced by the transition areas **62** form multi-axial hinges improving drape and flexibility of the finished absorbent tissue product **27**. In addition, the distinctive background textures **39** and **51** and curvilinear decorative elements are resistant to tear propagation improving tensile strength and machine runnability of the dried tissue web **23**.

[0123] In yet another advantage, the increased uniformity in spacing of the raised MD floats **60** possible with the present invention, while still producing distinctive background textures **39** and **51** and curvilinear line primary patterns **64**, maintains higher levels of caliper and CD stretch compared to decorative webs produced by the fabrics disclosed in U.S. Patent No. 5,429,686. The possibility of optimizing the uniformity and spacing of the raised MD floats **60** in the CD direction, without regard to spacing considerations in order to form the distinctive background textures **39** and **51** and curvilinear decorative elements in the dried tissue web **23**, is a significant advantage within the art of papermaking. The present invention allows for improved uniformity of the raised MD floats **60** in the CD direction, and the flexibility to form a multitude of complex distinctive background textures **39** and **51** and curvilinear decorative elements in the dried tissue web **23** within a single processing step.

EXAMPLE

[0124] In order to further illustrate the absorbent tissue products of the present invention, an uncreped throughdried tissue product was produced using the method substantially as illustrated in **FIGURE 27**. More specifically, a blended single-ply towel basesheet was made in which the fiber furnish comprised about 53% bleached recycled fiber (100% post consumer content), about 31% bleached northern softwood Kraft fiber, and about 16% bleached southern softwood Kraft fiber.

[0125] The fiber was pulped for 30 minutes at about 4-5 percent consistency and diluted to about 2.7 percent consistency after pulping. Kymene 557LX (commercially available from Hercules in Wilmington, DE) was added to the fiber at about 9 kilograms per tonne of pulp.

[0126] The headbox net slice opening was about 23 millimeters. The consistency of the stock fed to the headbox was about 0.26 weight percent.

[0127] The resulting wet tissue web **15** (shown in **FIGURE 27**) was formed on a c-wrap twin-wire, suction form roll, former with outer forming fabric **12** and inner forming fabric **13** being Voith Fabrics 2164-A33 fabrics (commercially available from Voith Fabrics in Raleigh, NC). The speed of the forming fabrics was about 6.9 meters per second. The newly-formed wet tissue web **15** was then

dewatered to a consistency of about 22-24 percent using vacuum suction from below inner forming fabric **13** before being transferred to transfer fabric **17**, which was traveling at about 6.3 meters per second (10 percent rush transfer). The transfer fabric **17** was a Voith Fabrics 2164-A33 fabric. Vacuum shoe **18** pulling about 420 millimeters of mercury vacuum was used to transfer the wet tissue web **15** to the transfer fabric **17**.

[0128] The wet tissue web **15** was then transferred to a throughdrying fabric **19** (Voith Fabrics t4803-7, substantially as shown in **FIGURE 28**). The throughdrying fabric **19** was traveling at a speed of about 6.3 meters per second. The wet tissue web **15** was carried over a pair of Honeycomb throughdryers (like the throughdryer **21** and commercially available from Valmet, Inc. (Honeycomb Div.) in Biddeford, ME) operating at a temperature of about 195 degrees C and dried to final dryness of at least about 97 percent consistency. The resulting uncreped dried tissue web **23** was then tested for physical properties without conditioning.

[0129] The fabric side of the resulting towel basesheet may appear substantially as shown in **FIGURE 29**. The air side of the resulting towel basesheet may appear substantially as shown in **FIGURE 30**.

[0130] The resulting dried tissue web **23** had the following properties: Basis Weight, 42 grams per square meter; CD Stretch, 5.5 percent; CD Tensile Strength, 1524 grams per 25.4 millimeters of sample width; Single Sheet Caliper, 0.55 millimeters; MD Stretch, 8.0 percent; MD Tensile Strength, 1765 grams per 25.4 millimeters of sample width; and, an wedding ring pattern as shown in **FIGURES 29** and **30**.

[0131] It will be appreciated that the foregoing examples and description, given for purposes of illustration, are not to be construed as limiting the scope of this invention, which is defined by the following claims and all equivalents thereto.

Claims

1. A woven sculpted fabric for the manufacture of a tissue web having a tissue contacting surface including at least a first group of strands and a second group of strands wherein the first group of strands extend in a first direction and the second group of strands extend in a second direction and the first group of strands are adapted to produce elevated floats and depressed sinkers, defining a three-dimensional fabric surface comprising:

a) a first background region having a set of substantially parallel first elevated floats separated by a set of substantially parallel first depressed sinkers, comprising first depressed sinkers positioned between adjacent first elevated floats and comprising first elevated floats positioned between adjacent first depressed sinkers;

- b) a second background region having a set of substantially parallel second elevated floats separated by a set of substantially parallel second depressed sinkers, comprising second depressed sinkers positioned between adjacent second elevated floats and comprising second elevated floats positioned between adjacent second depressed sinkers; and,
- c) a transition region positioned between the first and second background regions, wherein the first elevated floats of the first background region become the second elevated floats of the second background region and the first depressed sinkers of the first background region become the second depressed sinkers of the second background region.
2. The woven sculpted fabric of Claim 1, wherein at least one of the first elevated floats overlap at least one of the second elevated floats within the transition region.
 3. The woven sculpted fabric of Claim 1, wherein the direction of the first group of strands is in the machine direction.
 4. The woven sculpted fabric of Claim 1, wherein the direction of the first group of strands is at an acute angle to the machine direction.
 5. The woven sculpted fabric of Claim 1, wherein the direction of the first group of strands is substantially orthogonal to the second direction of the second group of strands.
 6. The woven sculpted fabric of Claim 1, wherein at least one of the first depressed sinkers is a multi-strand first depressed sinker.
 7. The woven sculpted fabric of Claim 1, wherein at least one of the second depressed sinkers is a multi-strand second depressed sinker.
 8. The woven sculpted fabric of Claim 1, wherein at least one of the first elevated floats is a multi-strand first elevated float.
 9. The woven sculpted fabric of Claim 1, wherein at least one of the second elevated floats is a multi-strand second elevated float.
 10. The woven sculpted fabric of Claim 1, wherein the transition region has greater surface depth than the first background region.
 11. The woven sculpted fabric of Claim 1, wherein the transition region has greater surface depth than the second background region.
 12. The woven sculpted fabric of Claim 1, wherein the transition region is filled.
 13. The woven sculpted fabric of Claim 1, wherein the transition region has substantially the same surface depth of the first background region.
 14. The woven sculpted fabric of Claim 1, wherein the transition region has substantially the same surface depth of the second background region.
 15. The woven sculpted fabric of Claim 1, wherein the maximum plane difference of the first elevated floats is at least about 0.12 mm.
 16. The woven sculpted fabric of Claim 1, wherein each of the first elevated floats has a width, and the maximum plane difference of the first elevated floats is at least about 30% of the width of one of the first elevated floats.
 17. The woven sculpted fabric of Claim 1, wherein the maximum plane difference of the second elevated floats is at least about 0.12 mm.
 18. The woven sculpted fabric of Claim 1, wherein each of the second elevated floats has a width, and the maximum plane difference of the second elevated floats is at least about 30% of the width of one of the second elevated floats.
 19. The woven sculpted fabric of Claim 1, wherein the first background region has a first background texture and the second background region has a second background texture.
 20. The woven sculpted fabric of Claim 19, wherein the first background texture of the first background region is substantially the same as the second background texture of the second background region.
 21. The woven sculpted fabric of Claim 20, wherein the first background texture of the first background region is different than the second background texture of the second background region.
 22. The woven sculpted fabric of Claim 1, wherein the maximum distance between adjacent first elevated floats is at least about 0.3 mm.
 23. The woven sculpted fabric of Claim 22, wherein the maximum distance between adjacent first elevated floats is greater than the width of one of the adjacent first elevated floats.
 24. The woven sculpted fabric of Claim 1, wherein the maximum distance between adjacent second elevated floats is at least about 0.3 mm.

25. The woven sculpted fabric of Claim 24, wherein the maximum distance between adjacent second elevated floats is greater than the width of one of the adjacent second elevated floats. 5
26. The woven sculpted fabric of Claim 1, wherein the woven sculpted fabric is a forming wire. 10
27. The woven sculpted fabric of Claim 1, wherein the woven sculpted fabric is a through air drying fabric. 15
28. The woven sculpted fabric of Claim 1, wherein the woven sculpted fabric is a transfer fabric. 20
29. The woven sculpted fabric of Claim 1, wherein the tissue contacting surface of the woven sculpted fabric is non-macroscopically monoplanar. 25
30. The woven sculpted fabric of Claim 1, wherein the transition region is filled with a polymeric resin. 30
31. The woven sculpted fabric of Claim 1, wherein each first elevated float has a first beginning point and a first ending point, each second elevated float has a second beginning point and a second ending point wherein the first ending point of at least one of the first elevated float is separated in the transition region by a gap having a width ranging from about 10 mm to about 0 mm from the second ending point of at least one of the nearest second elevated floats. 35
32. The woven sculpted fabric of Claim 31, wherein the gap has a width ranging from about 4 mm to about 0 mm. 40
33. A method of making a tissue product comprising:
- a) depositing an aqueous suspension of paper-making fibers onto a forming fabric thereby forming a wet tissue web;
 - b) transferring the wet tissue web to a woven sculpted fabric having a tissue contacting surface including at least a first group of strands and a second group of strands wherein the first group of strands extend in a first direction and the second group of strands extend in a second direction and the first group of strands are adapted to produce elevated floats and depressed sinkers, defining a three-dimensional fabric surface comprising:
 - i) a first background region having a set of substantially parallel first elevated floats separated by a set of substantially parallel first depressed sinkers, comprising first depressed sinkers positioned between adjacent first elevated floats and comprising first elevated floats positioned between adjacent first depressed sinkers;
 - ii) a second background region having a set of substantially parallel second elevated floats separated by a set of substantially parallel second depressed sinkers, comprising second depressed sinkers positioned between adjacent second elevated floats and comprising second elevated floats positioned between adjacent second depressed sinkers; and,
 - iii) a transition region positioned between the first and second background regions, wherein the first elevated floats of the first background region become the second elevated floats of the second background region and the first depressed sinkers of the first background region become the second depressed sinkers of the second background region; and,
- c) drying the wet tissue web.
34. The method of Claim 33, wherein the wet tissue web has a consistency of at least about 20 percent when the wet tissue web is transferred to the woven sculpted fabric. 45
35. The method of Claim 33, wherein drying the wet tissue web comprises noncompressive drying. 50
36. The method of Claim 35, wherein the noncompressive drying the wet tissue web comprises through air drying on a throughdrying fabric thereby forming a dried tissue web. 55
37. The method of Claim 36, wherein the speed of the throughdrying fabric is from about 10 to about 80 percent slower than the speed of the forming fabric.
38. The method of Claim 36, further comprising transferring the wet tissue web from the forming fabric to a transfer fabric before transferring the wet tissue web to the throughdrying fabric wherein the speed of the transfer fabric is from about 10 to about 80 percent slower than the speed of the forming fabric.
39. The method of Claim 38, wherein the speed of the transfer fabric is substantially the same as the speed of the woven sculpted fabric.
40. The method of Claim 33, wherein the wet tissue web is macroscopically rearranged to conform to the tissue contacting surface of the woven sculpted fabric.
41. The method of Claim 33, wherein the tissue contacting surface of the woven sculpted fabric is non-macroscopically monoplanar.

42. The method of Claim 36, wherein the dried tissue web is not creped.
43. The method of Claim 36, wherein the dried tissue web is transferred to a Yankee dryer. 5
44. The method of Claim 43, wherein the dried tissue web is removed from the Yankee dryer without creping. 10
45. The method of Claim 43, wherein the dried tissue web is removed from the Yankee dryer with creping.
46. The method of Claim 36, further comprising dewatering the wet tissue web by at least one of displacement dewatering, capillary dewatering, and application of an air press. 15
47. The method of Claim 36, further comprising dewatering the wet tissue web by at least one of impulse drying, radiofrequency drying, long nip pressing, wet pressing, steam drying, high intensity nip drying, and infrared drying. 20
48. The method of Claim 33, wherein the wet tissue web is treated with a chemical strength agent and creped two or more times. 25
49. The method of any of Claims 33 to 48, in which the fabric is as claimed in any of Claims 2 to 32. 30
50. A tissue product made by the method of any of Claims 33 to 49.
51. The tissue product of Claim 50, wherein the tissue product has a density that is substantially uniform. 35
52. The tissue product of Claim 50 or 51, wherein the tissue product has a machine direction stretch of greater than about 10 percent, further comprising a softness agent disposed on a surface of the tissue product. 40
53. The tissue product of Claim 50, wherein the tissue product has a machine direction stretch of greater than about 10 percent. 45

50

55

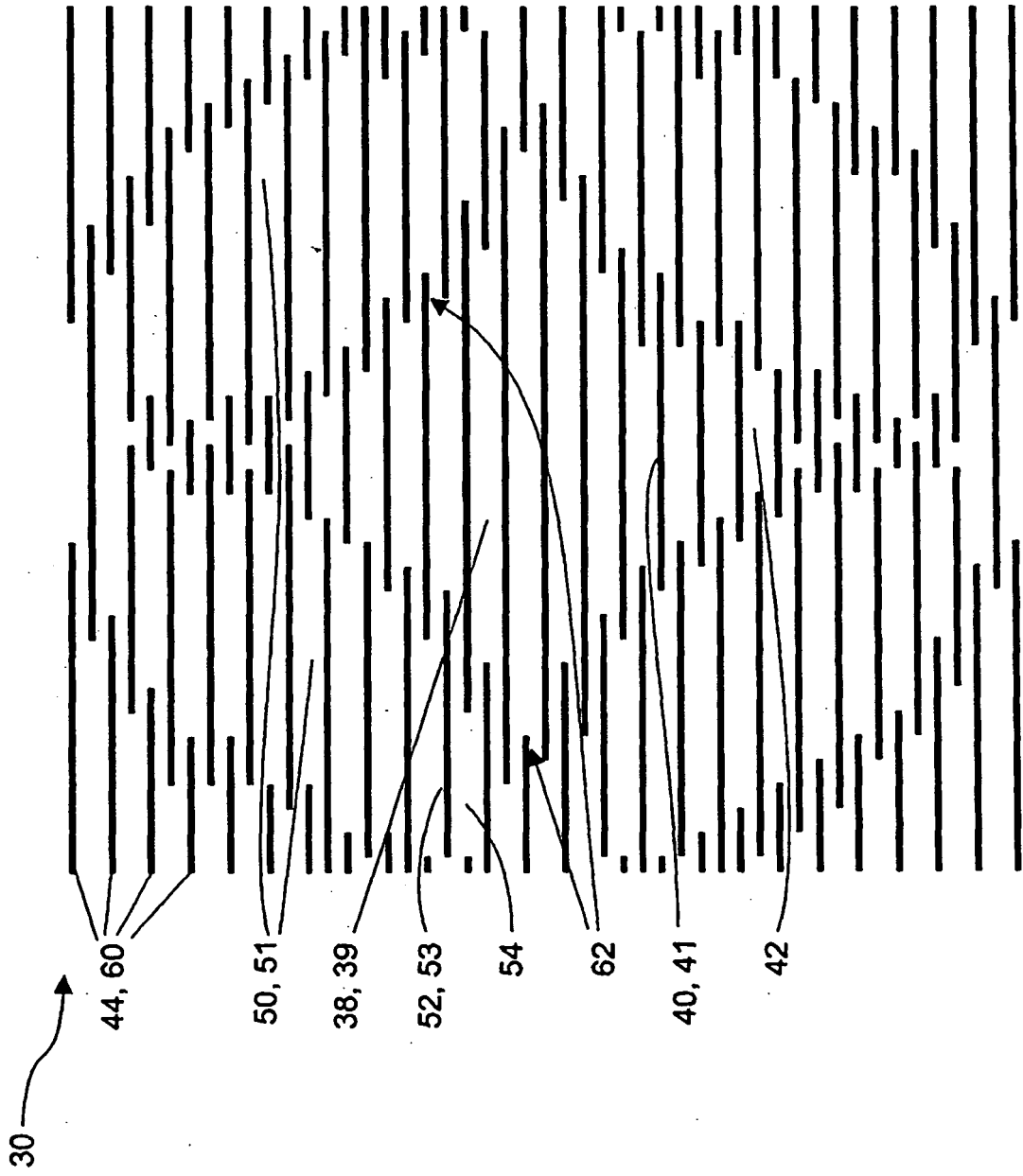

FIGURE 1A

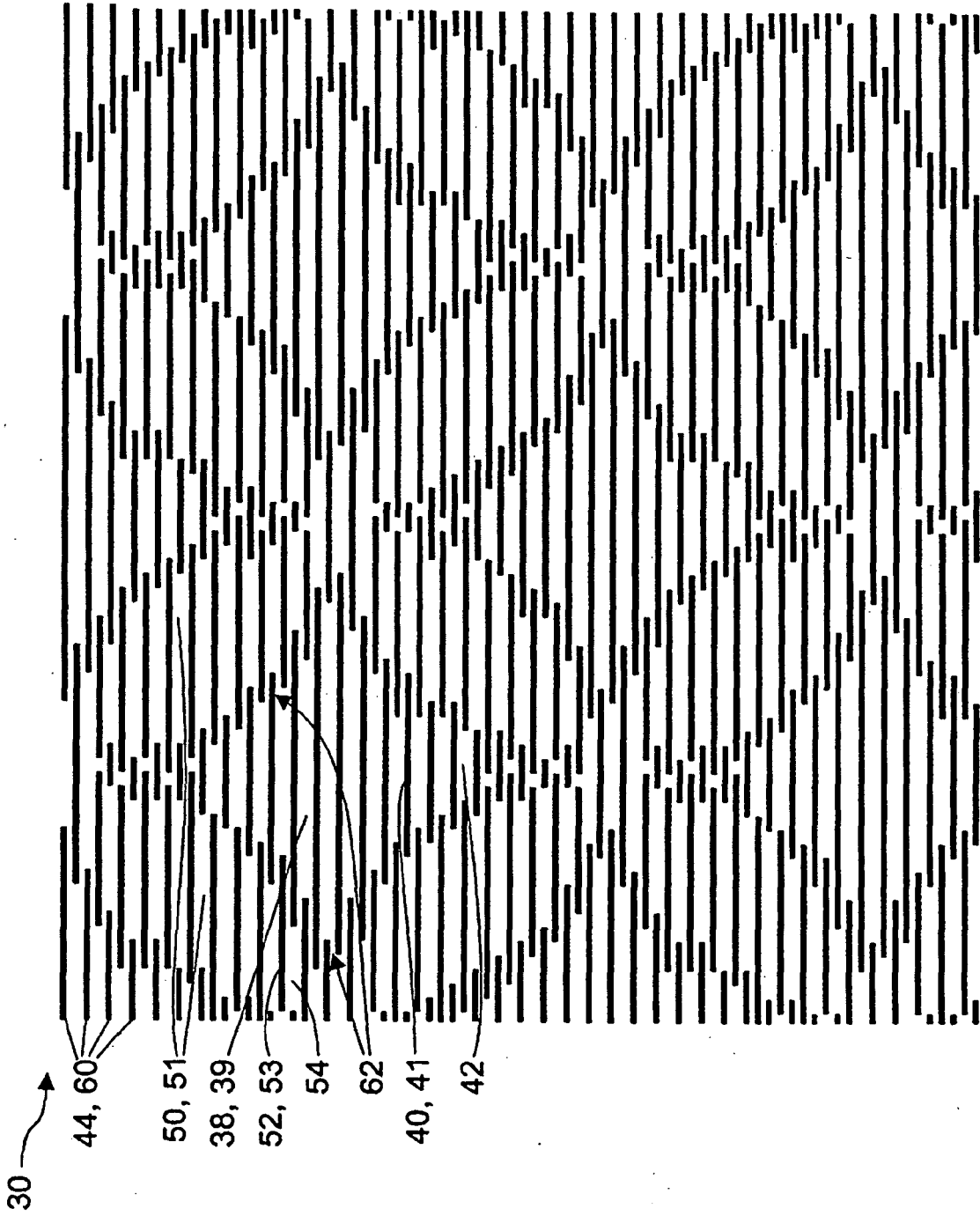

FIGURE 1B

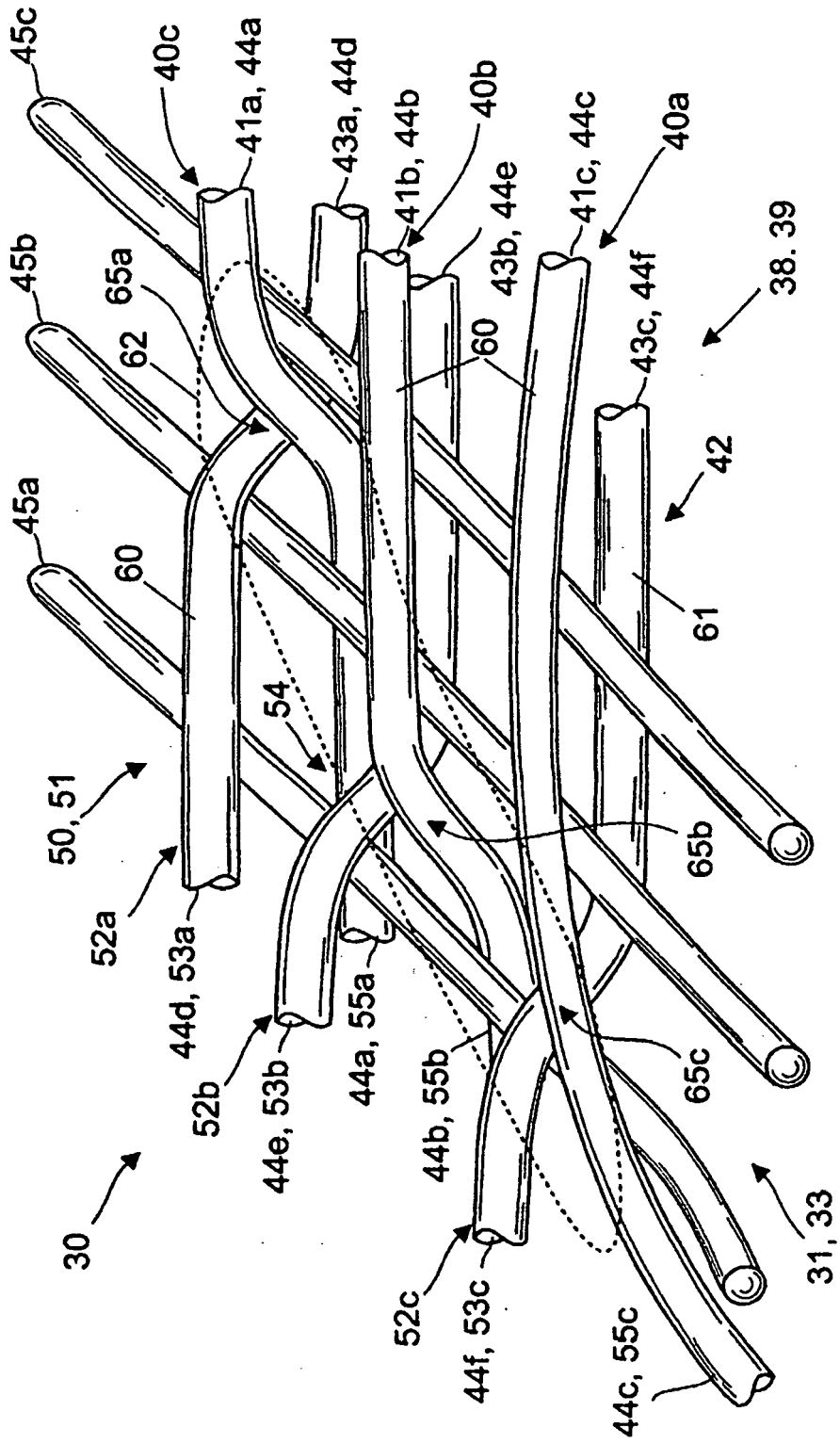

FIGURE 2

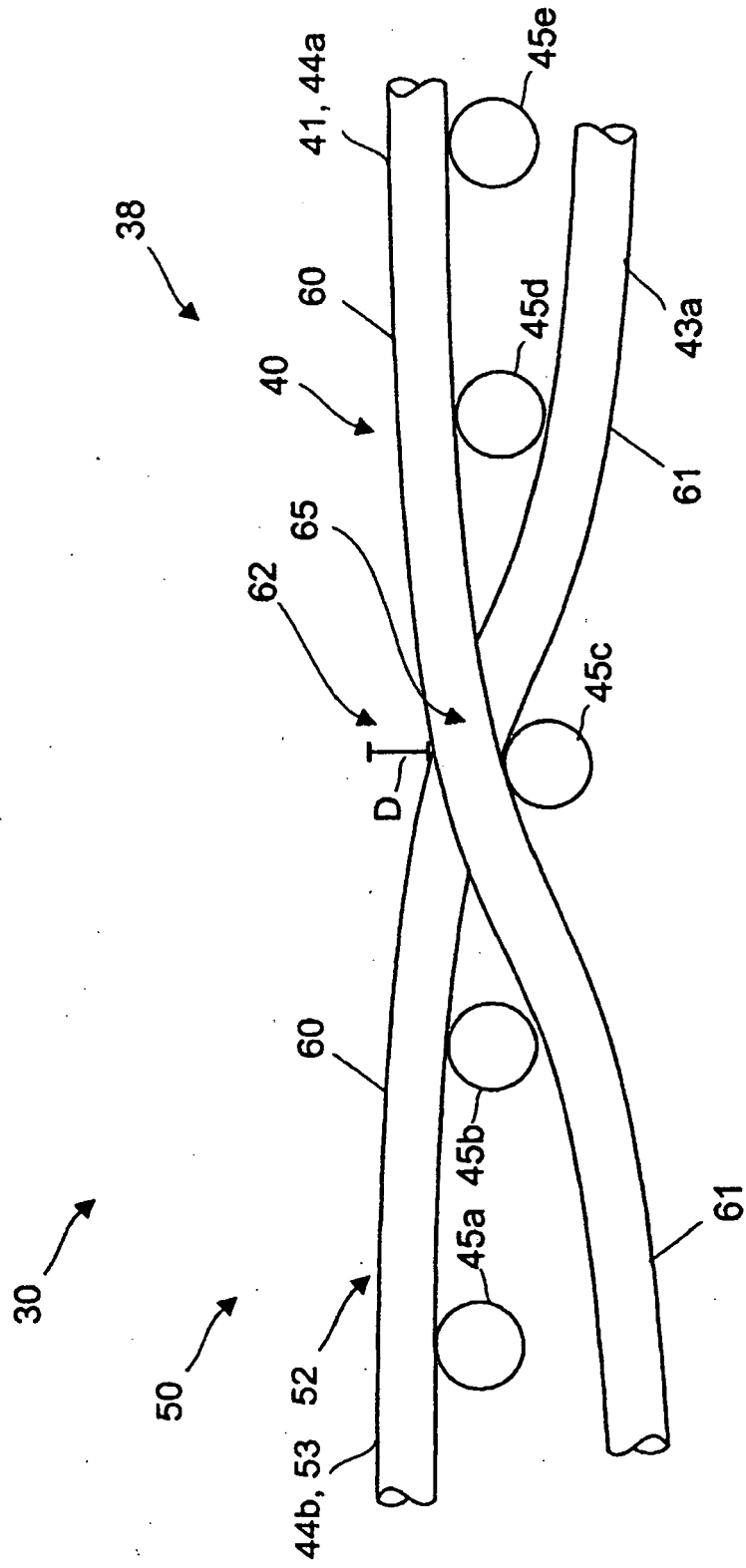

FIGURE 3

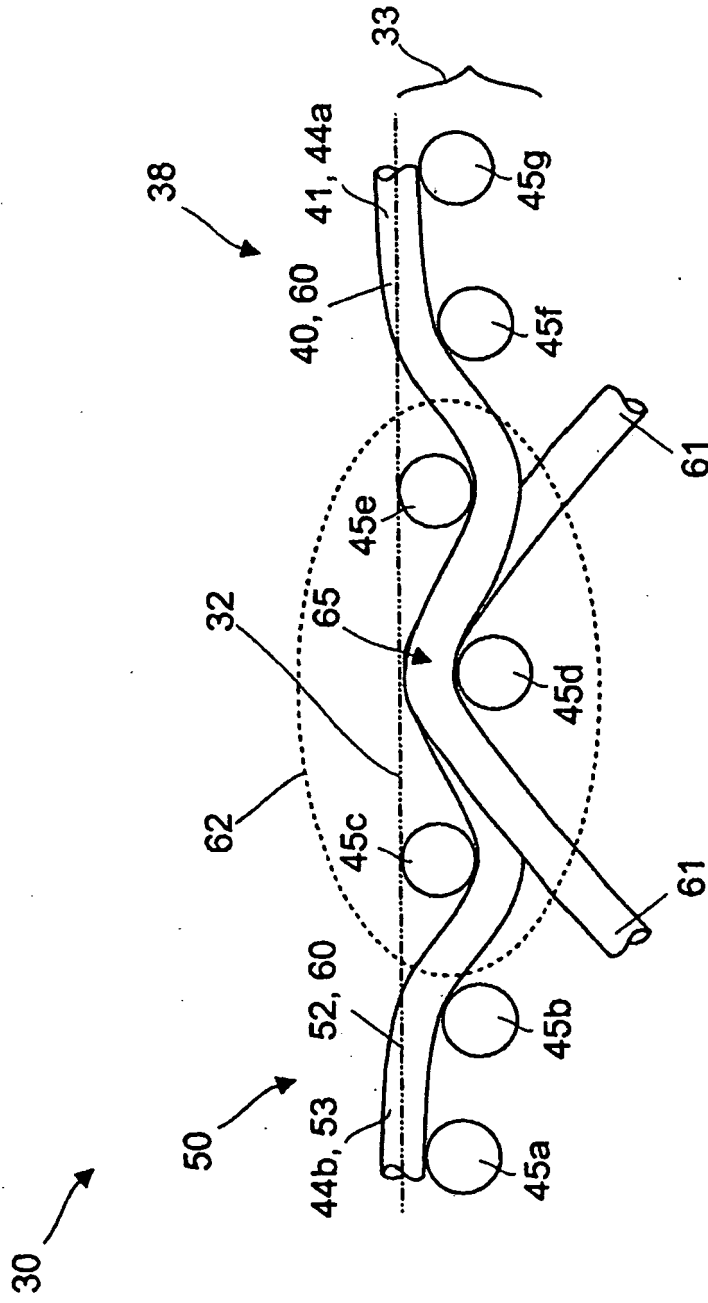

FIGURE 4

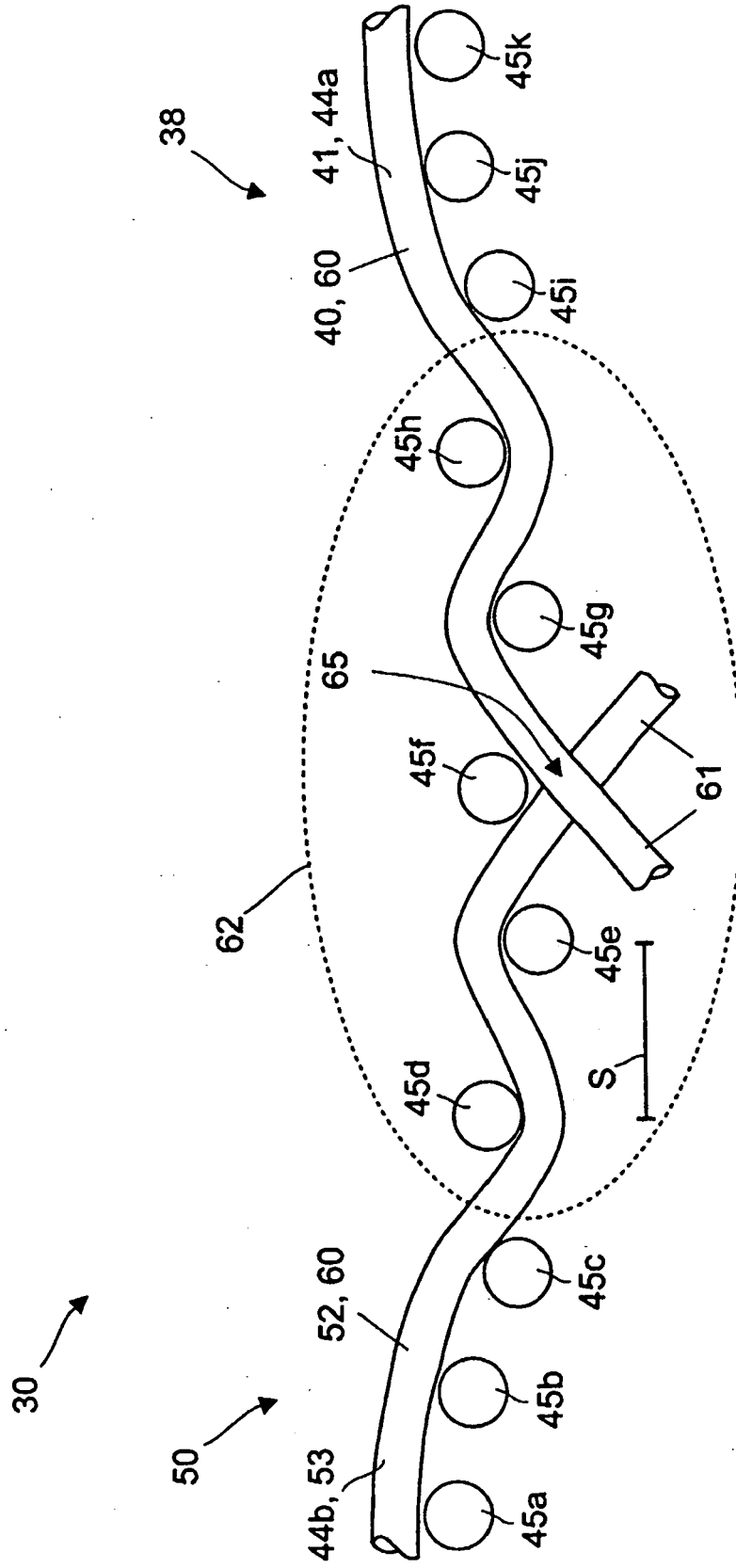

FIGURE 5

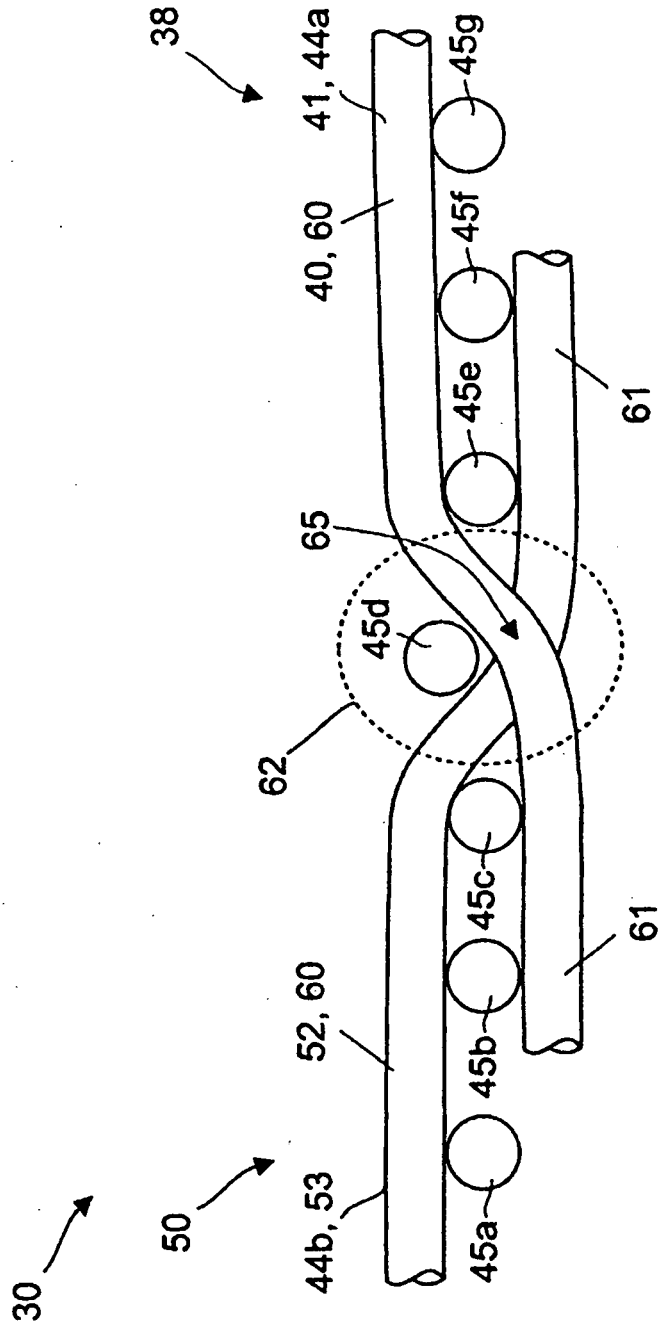

FIGURE 6

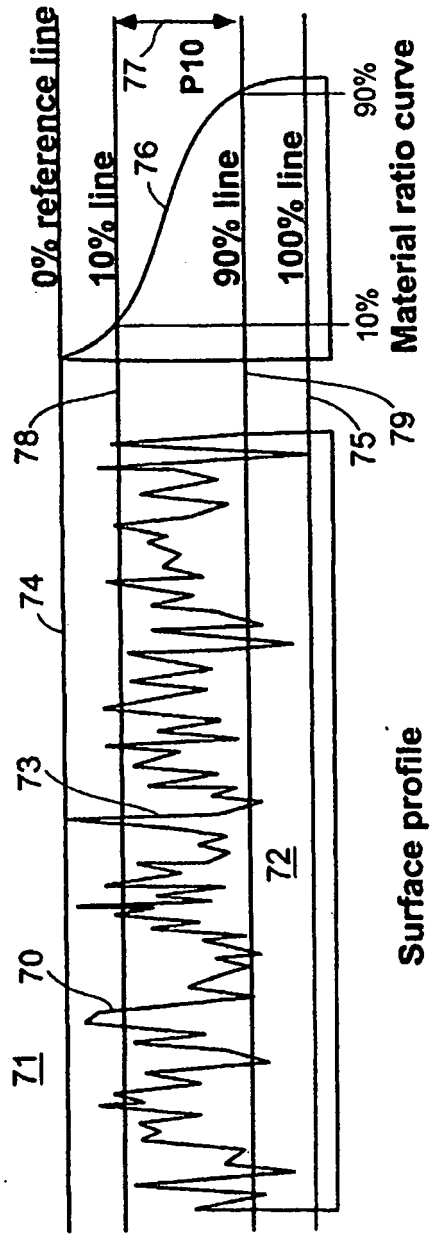

FIGURE 7

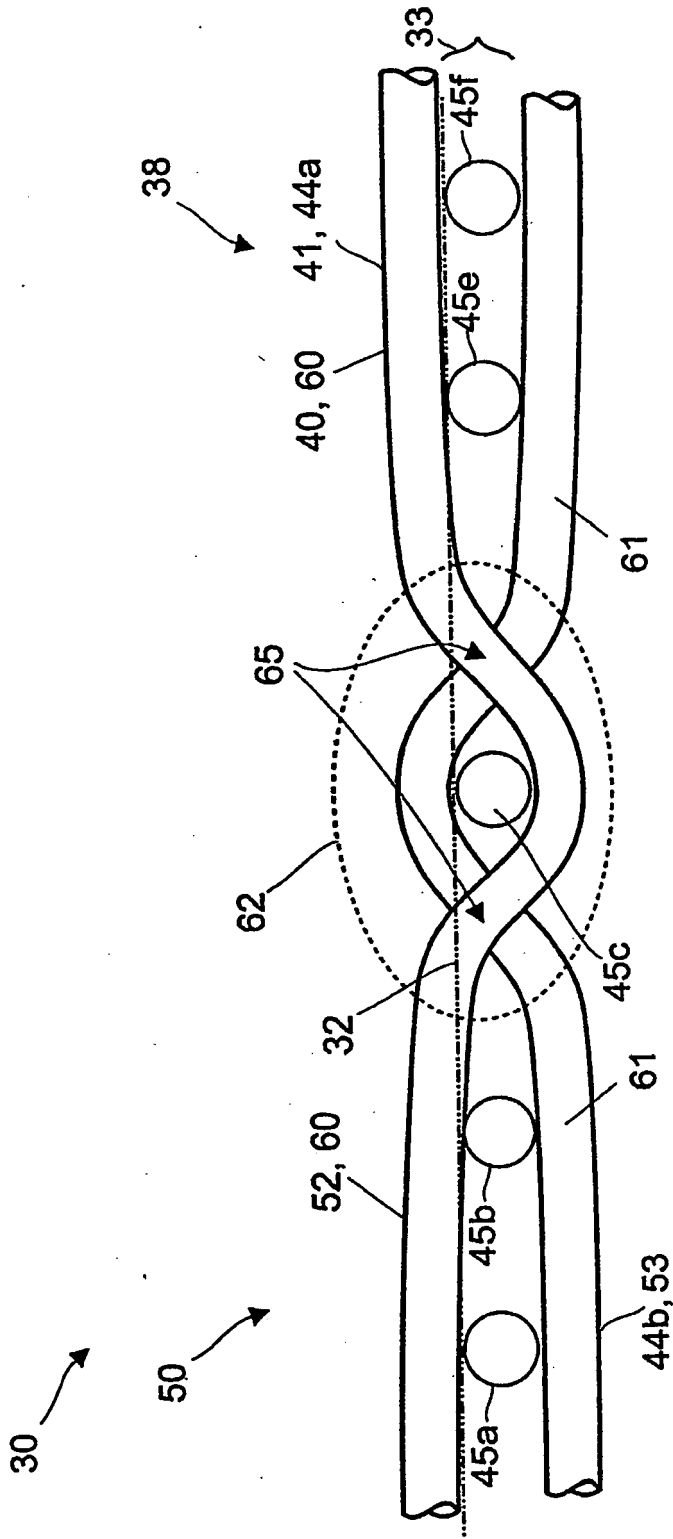

FIGURE 8

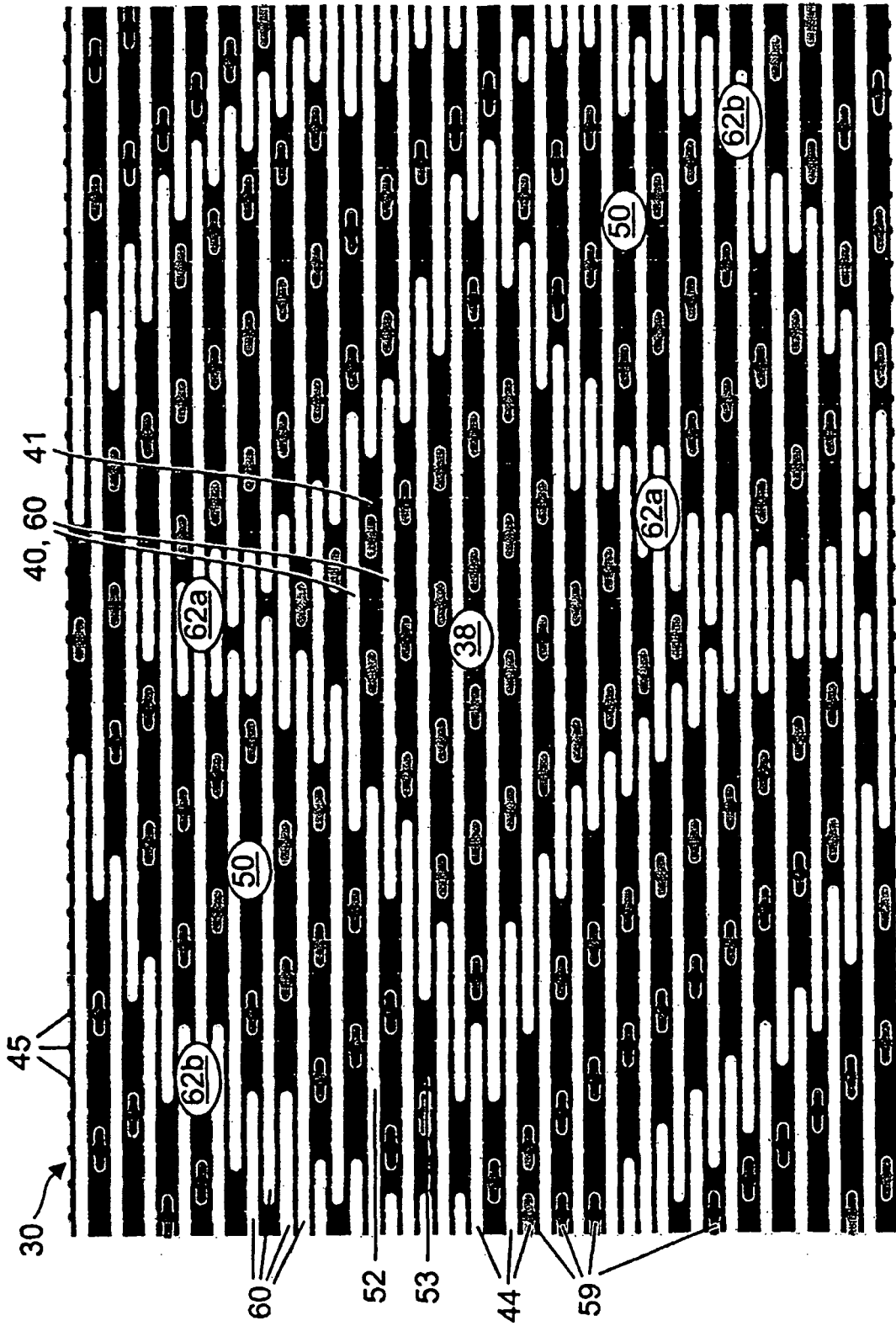

FIGURE 9

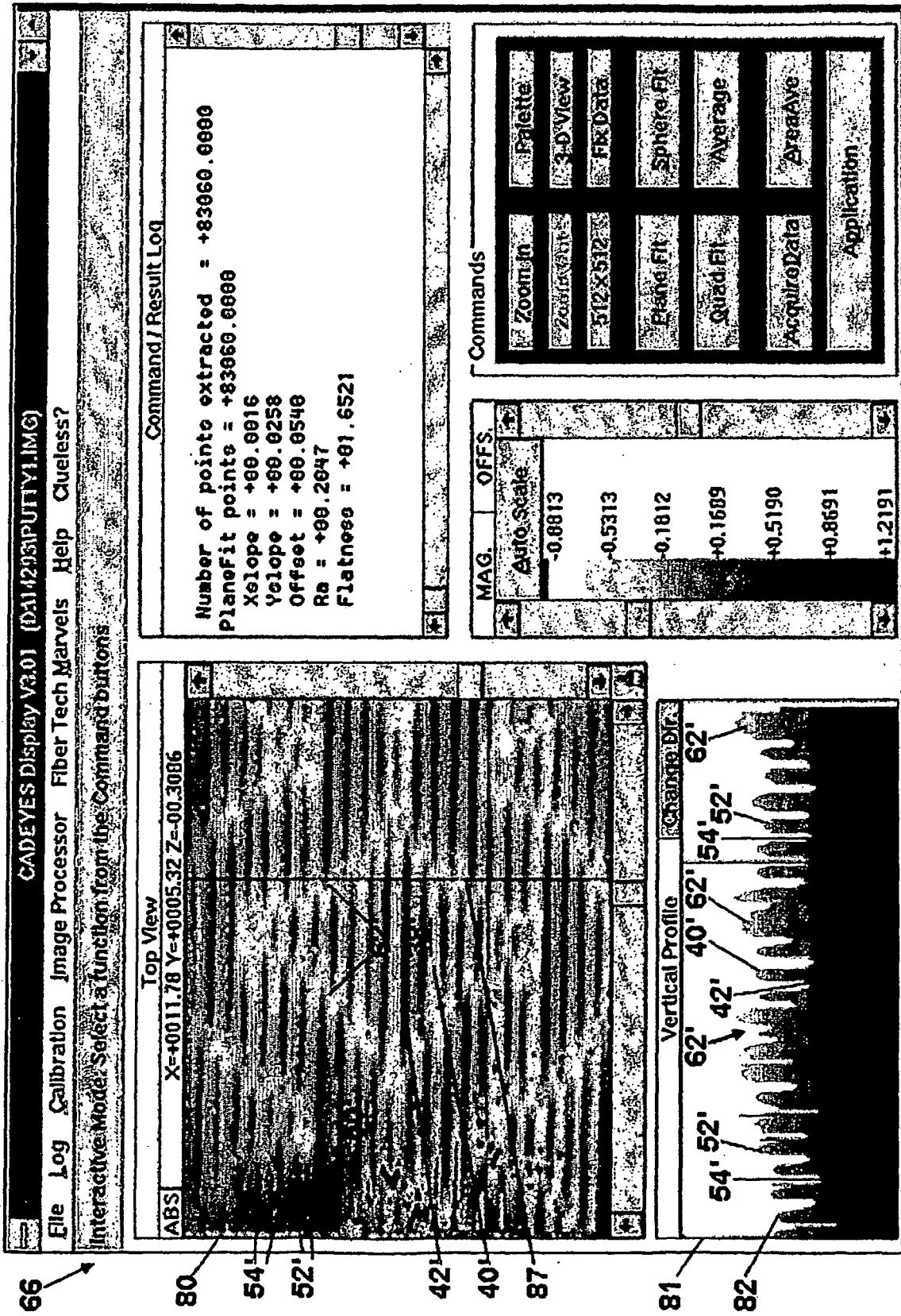

FIGURE 10.

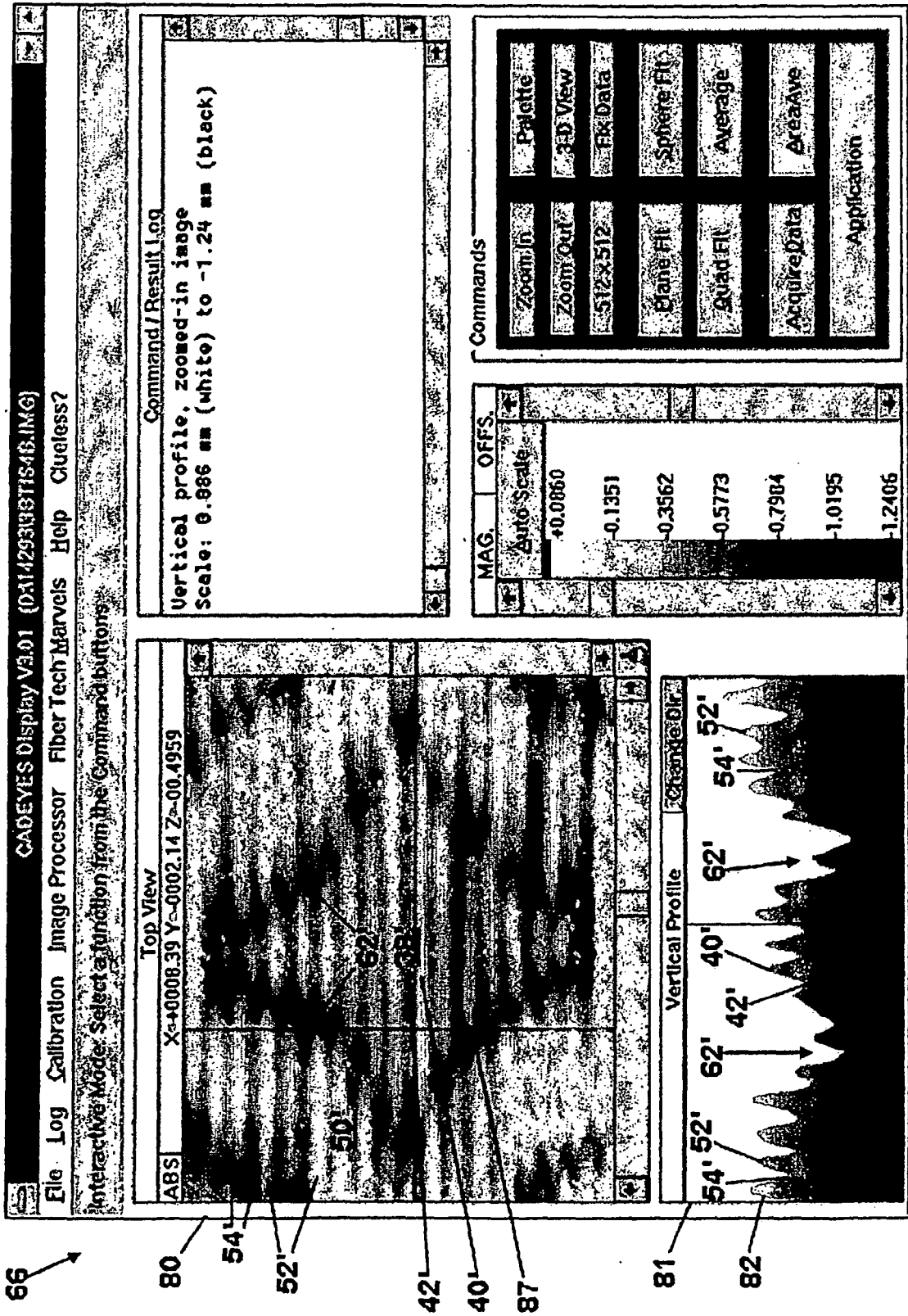

FIGURE 11.

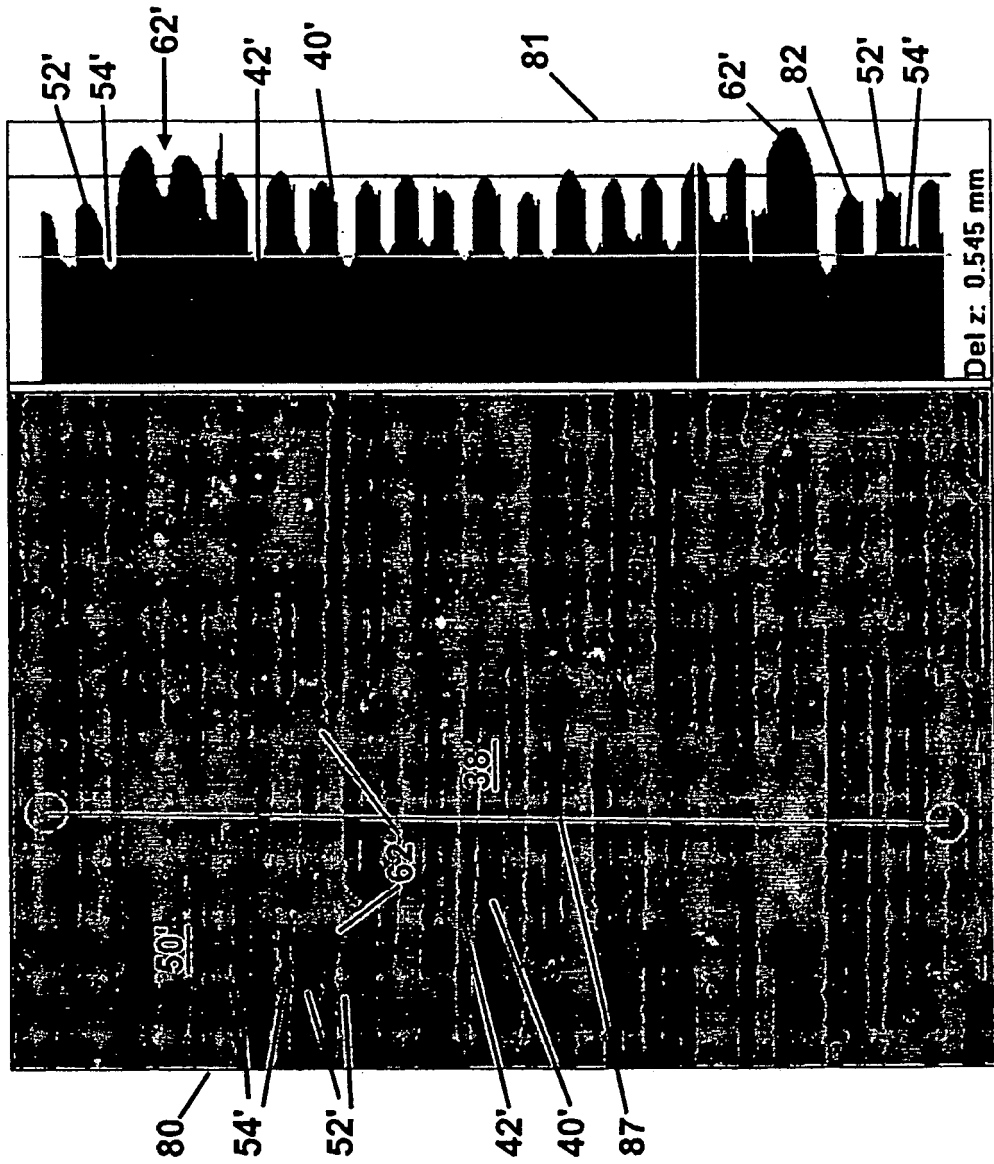

FIGURE 12.

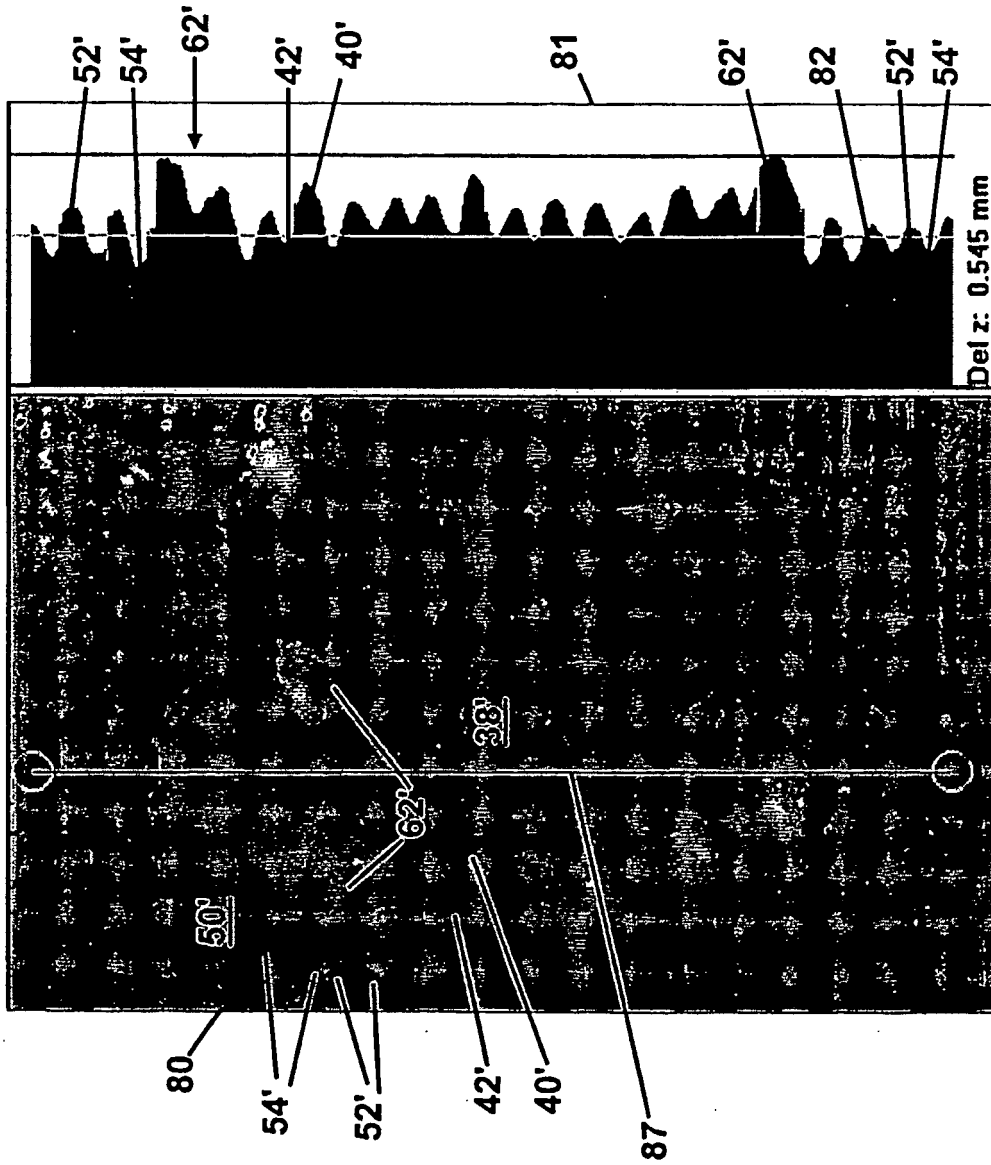

FIGURE 13.

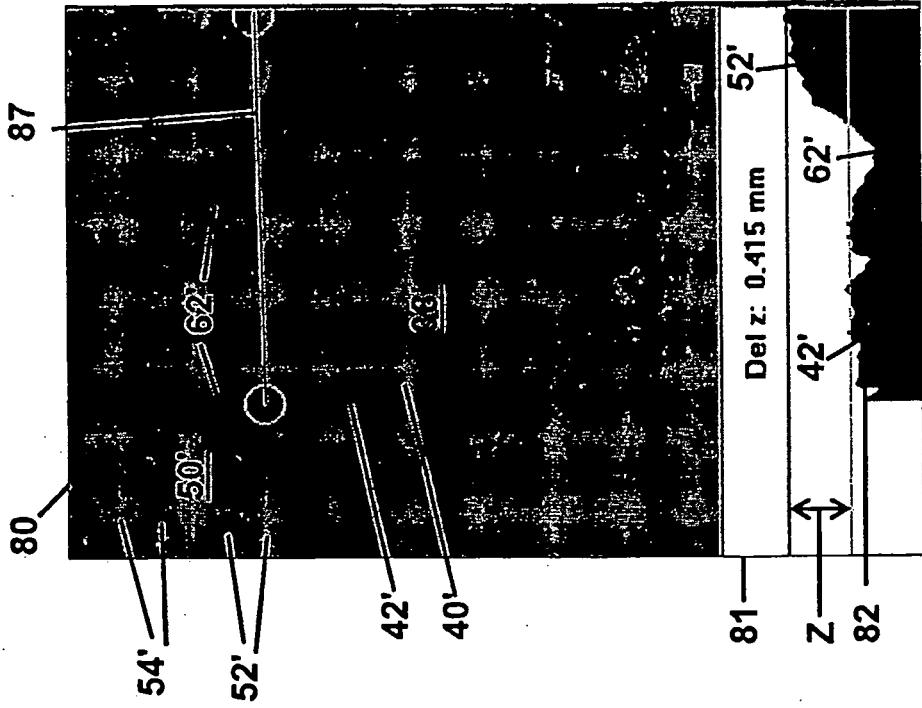

FIGURE 15.

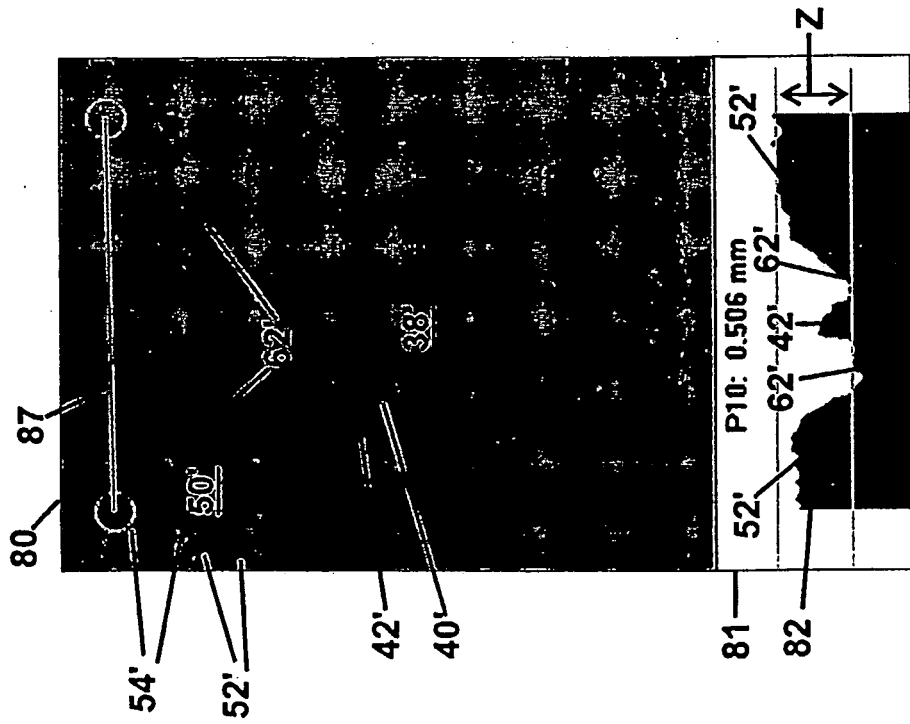

FIGURE 14.

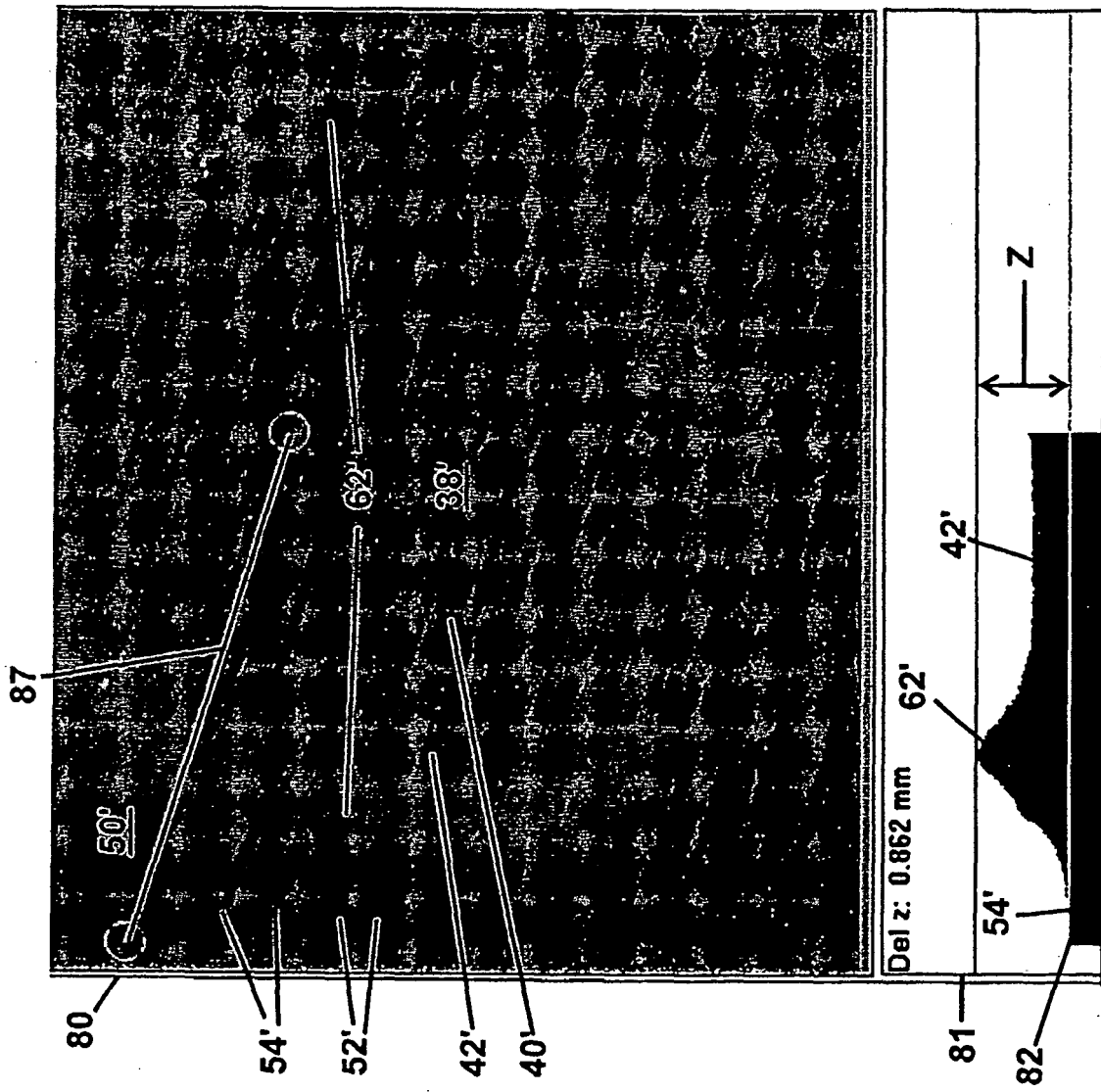

FIGURE 16.

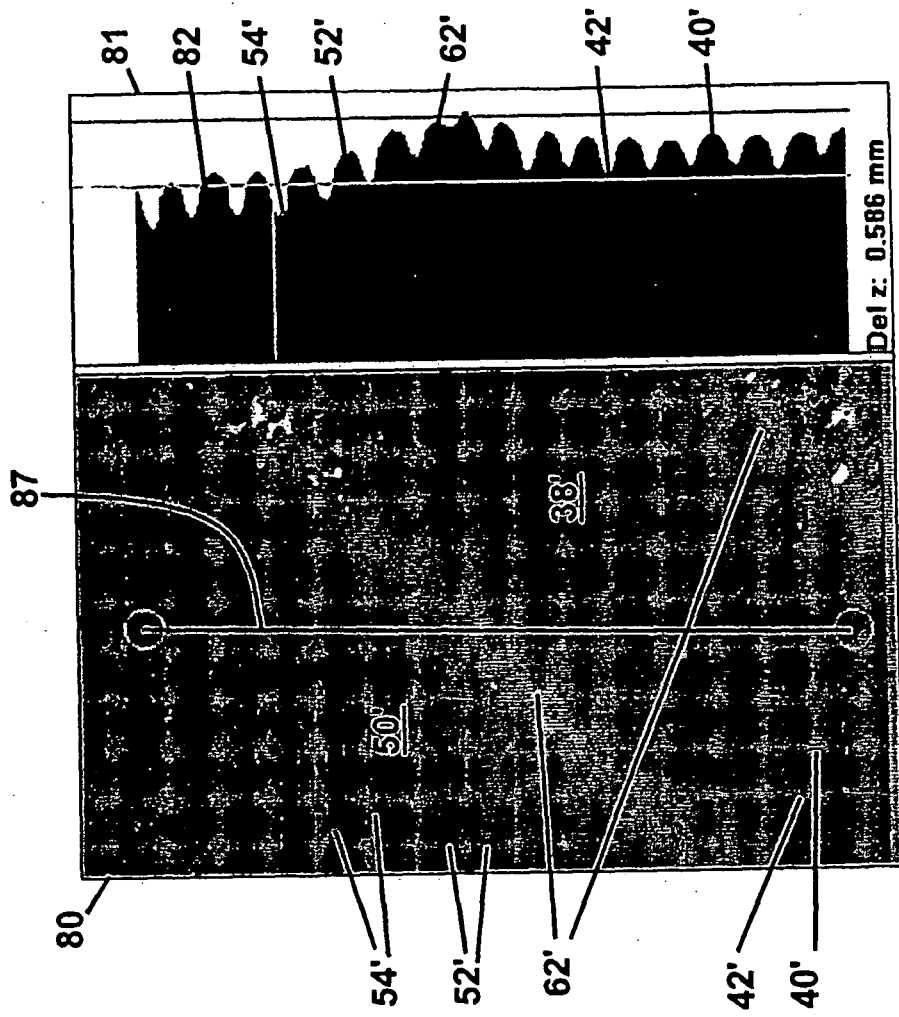

FIGURE 17.

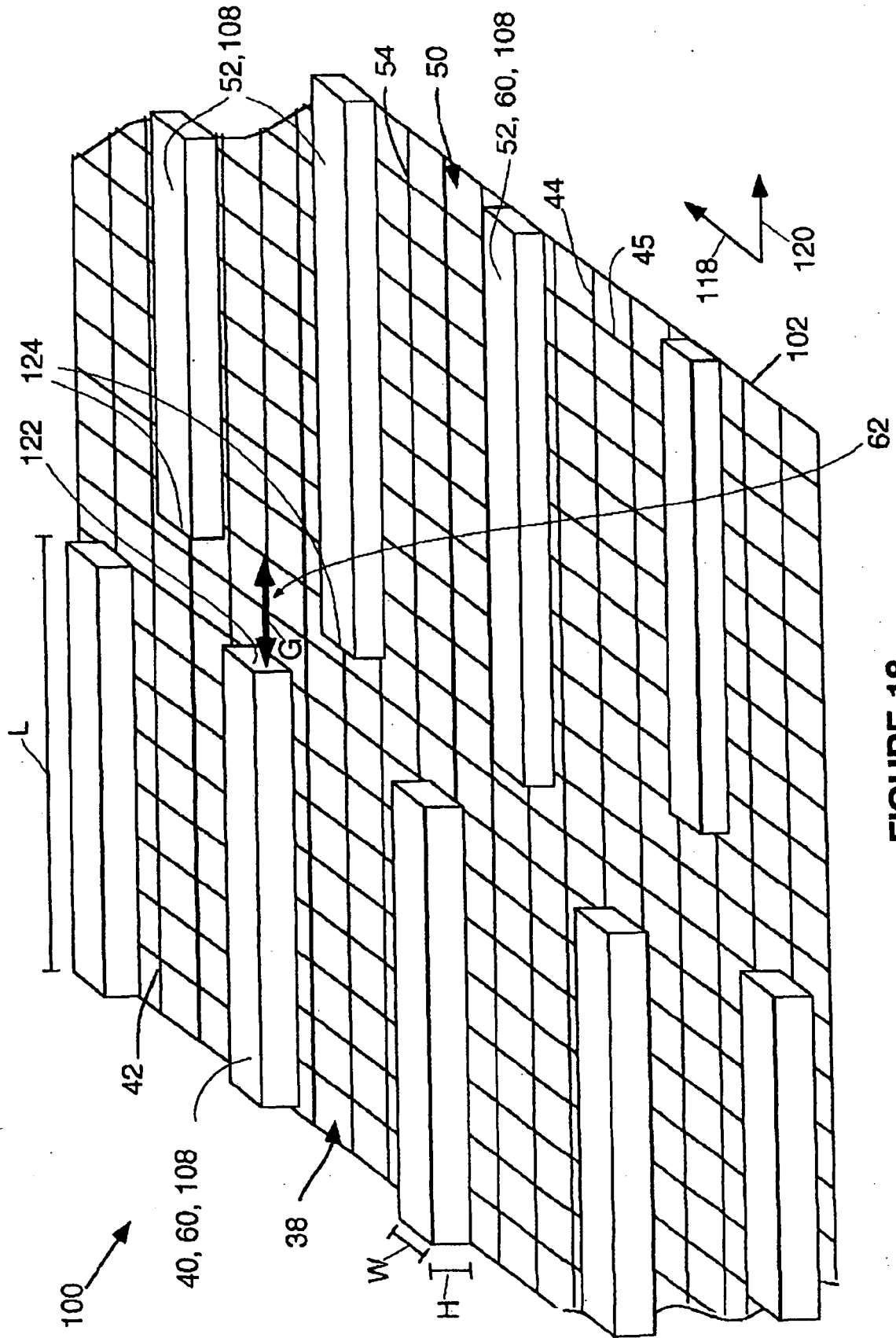

FIGURE 18

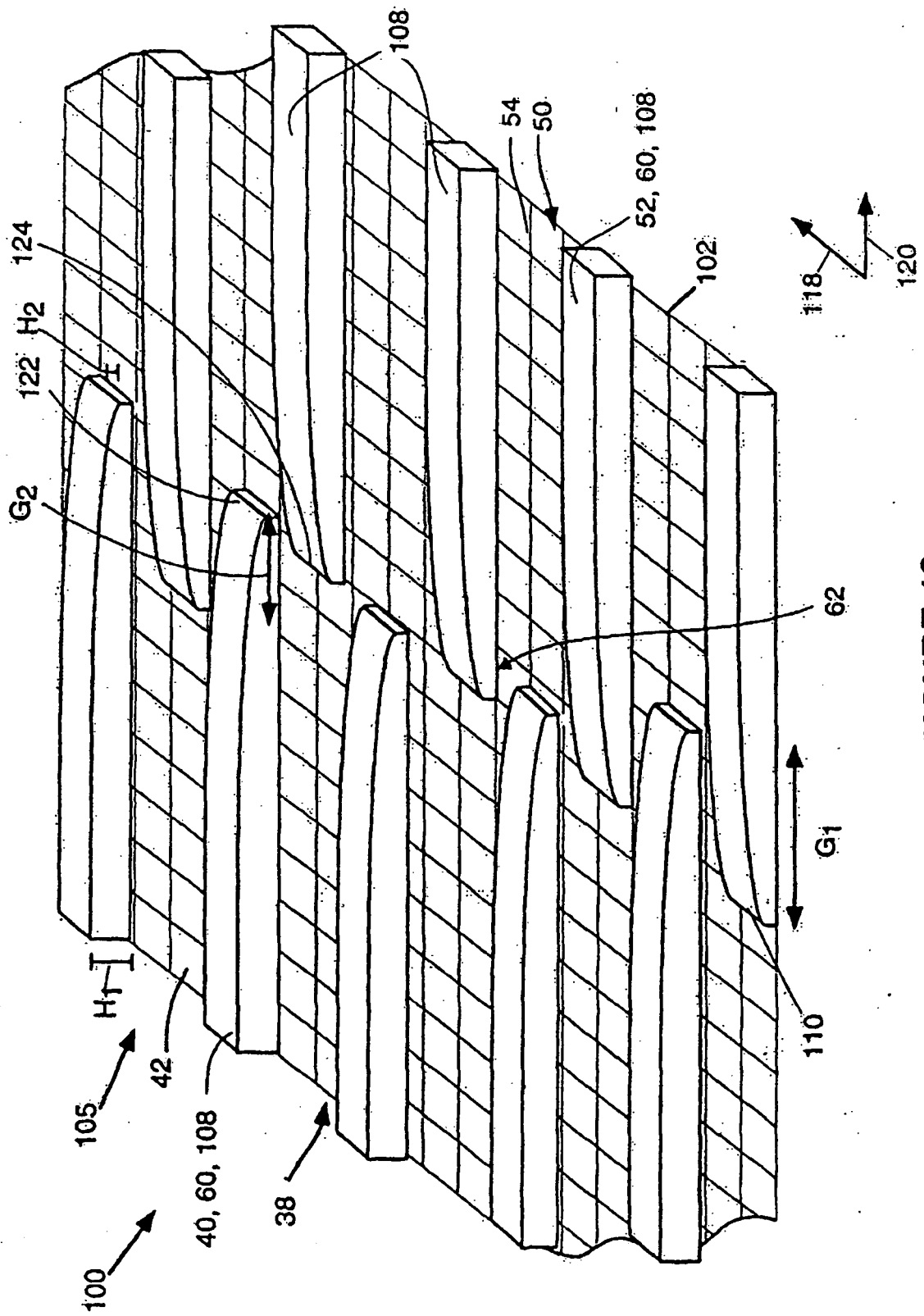

FIGURE 19

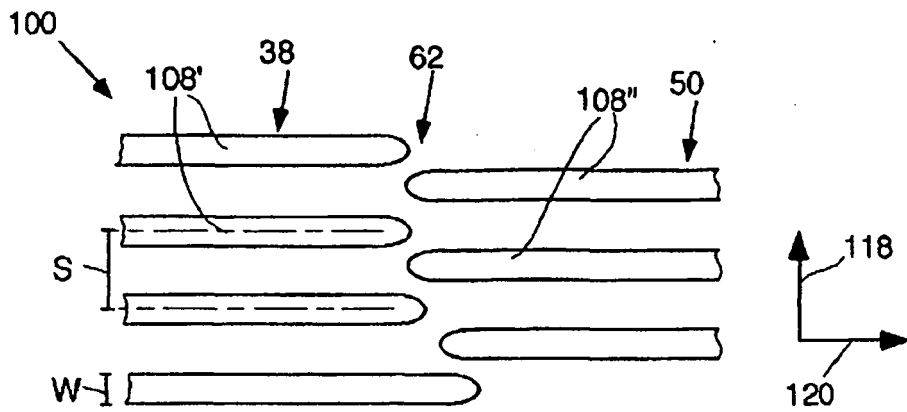

FIGURE 20

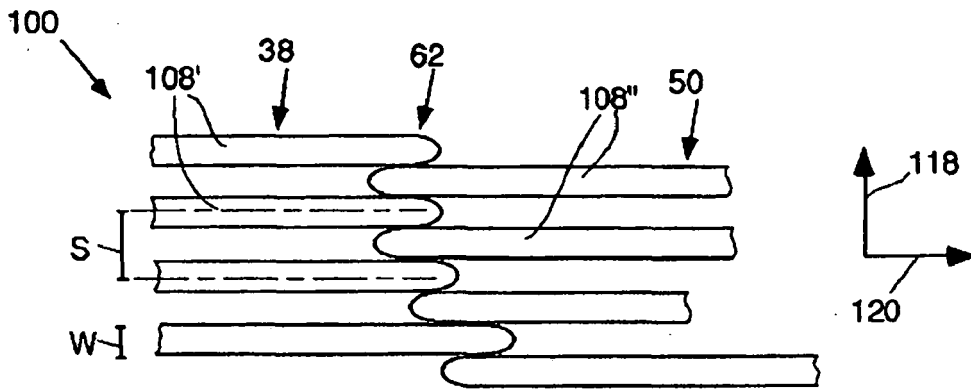

FIGURE 21

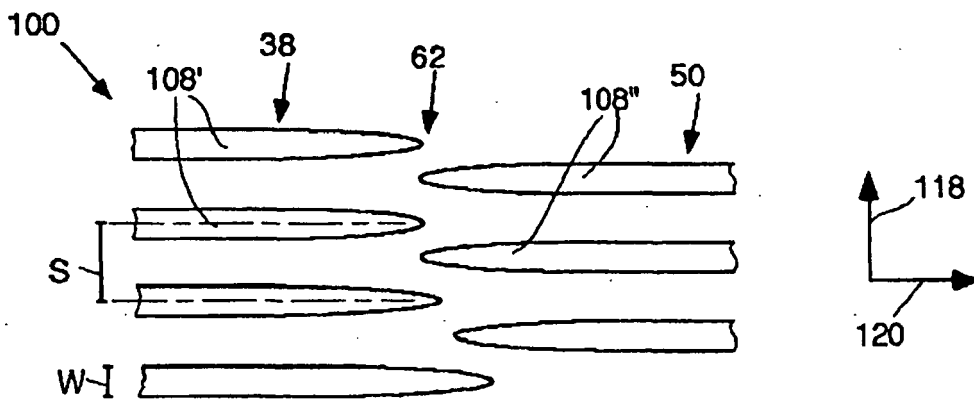

FIGURE 22

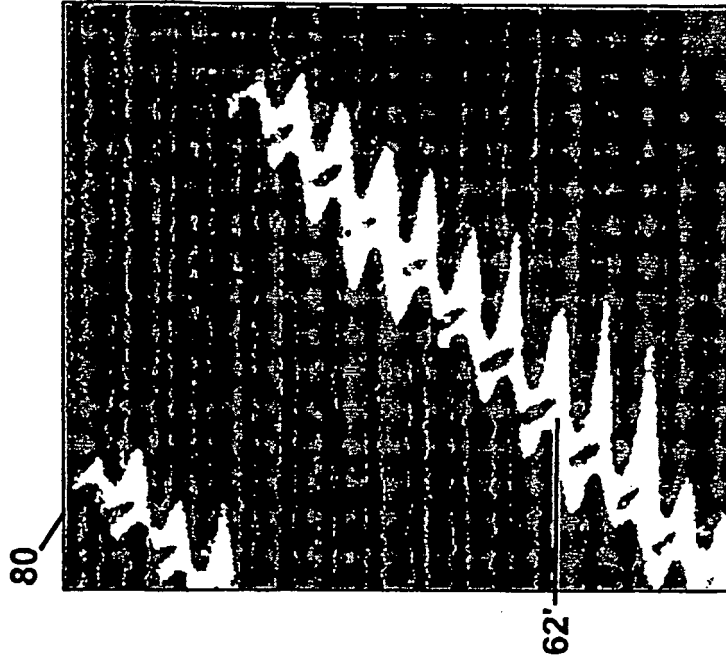

FIGURE 24.

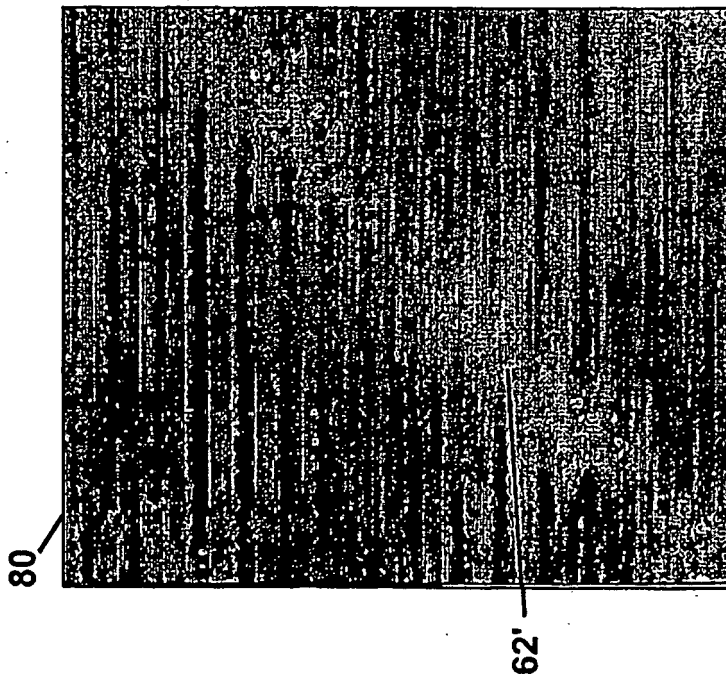

FIGURE 23.

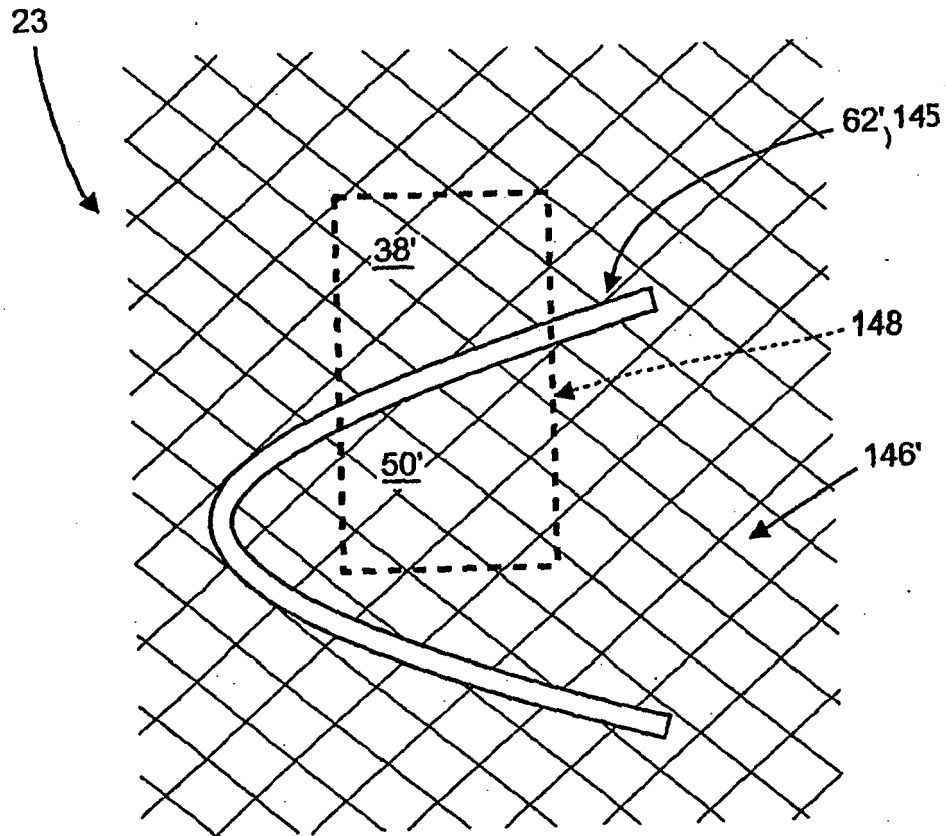

FIGURE 25

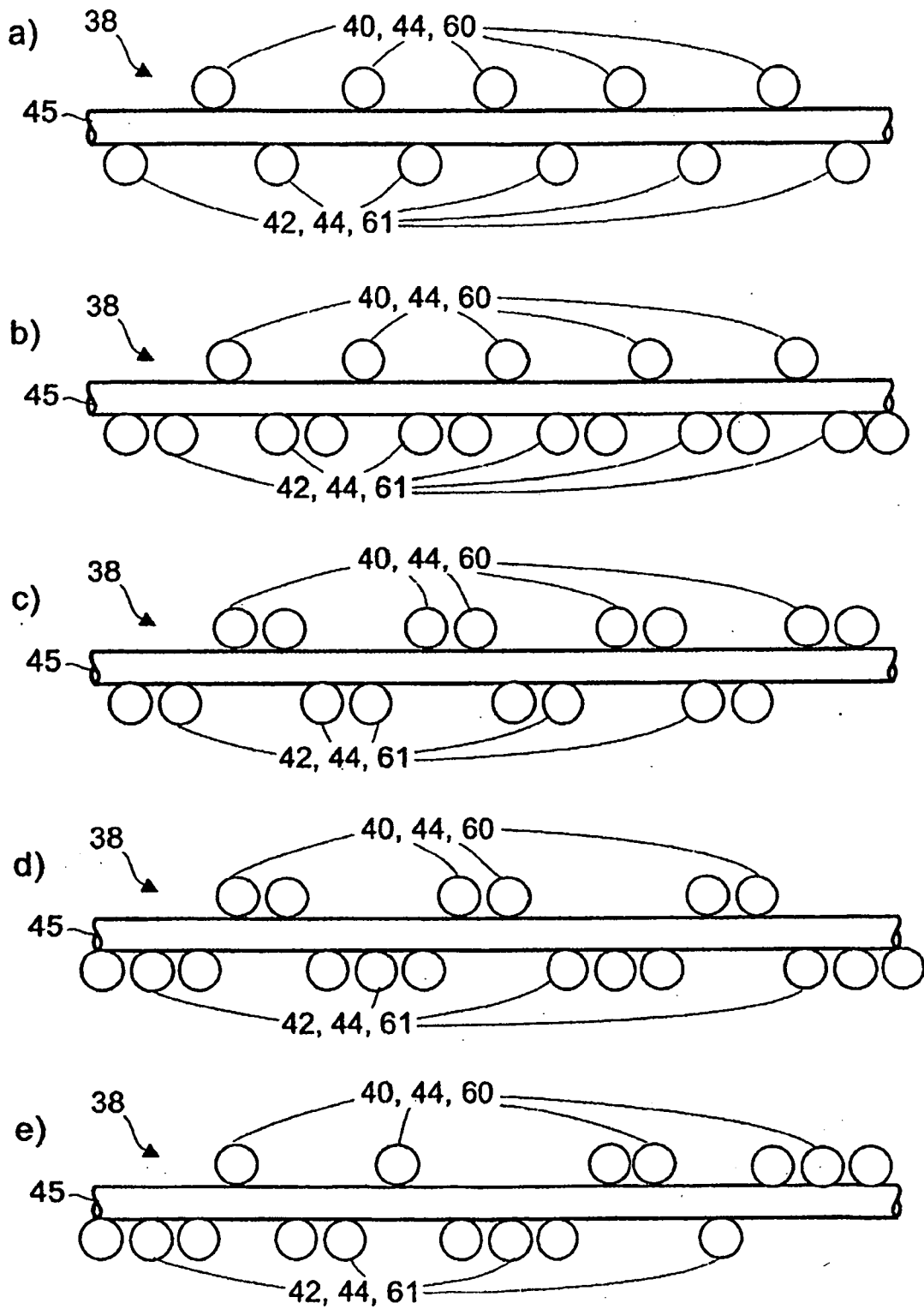

FIGURE 26

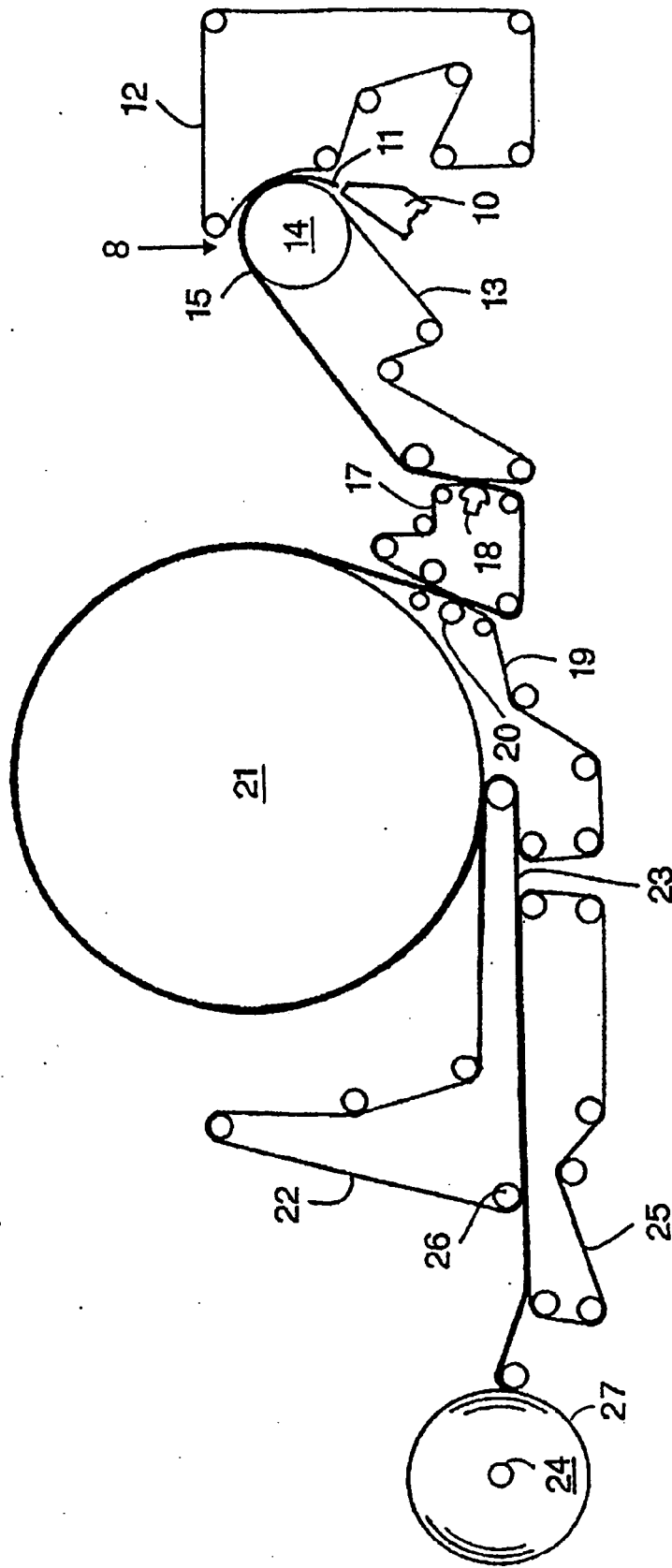

FIGURE 27

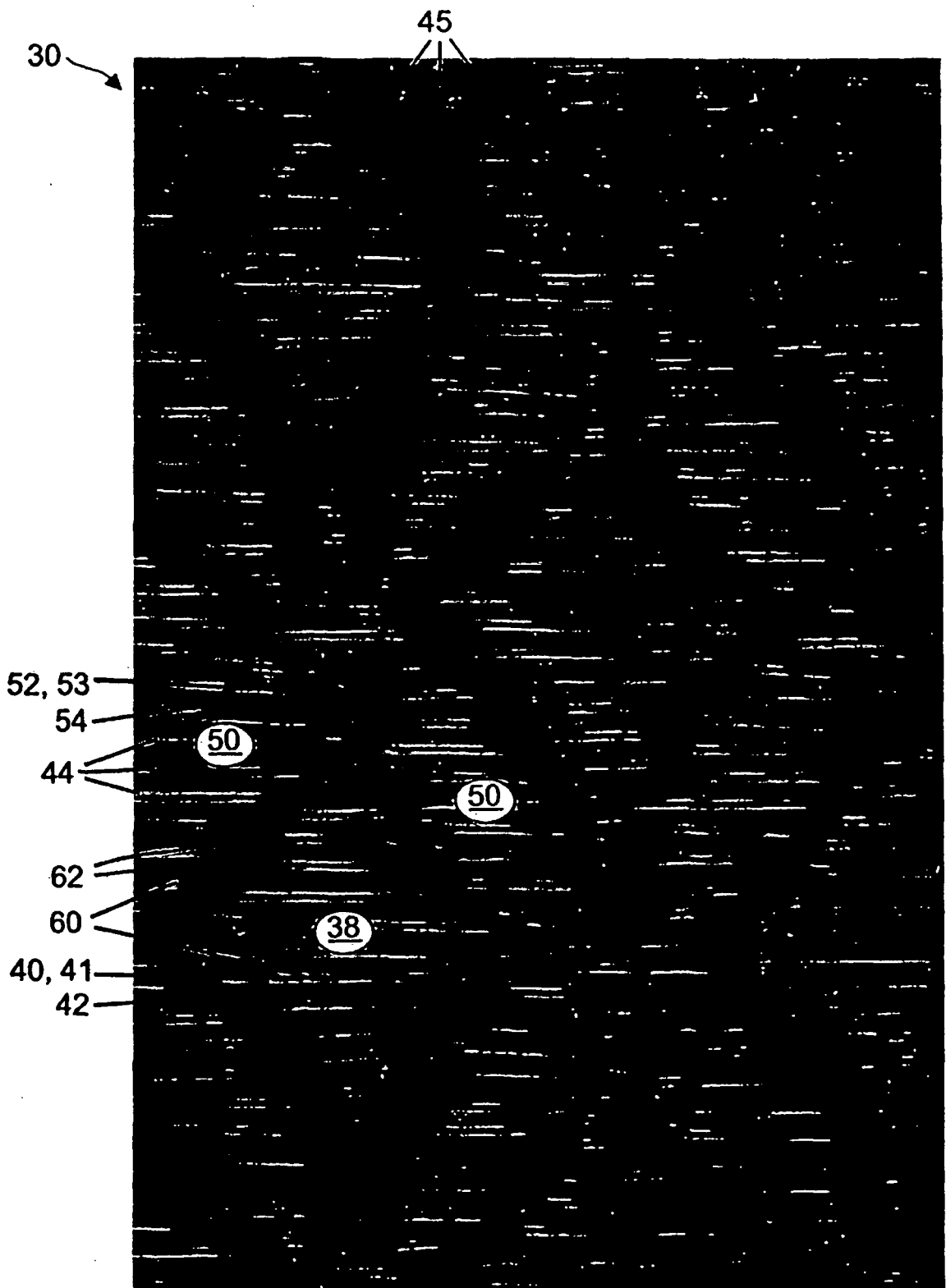

FIGURE 28

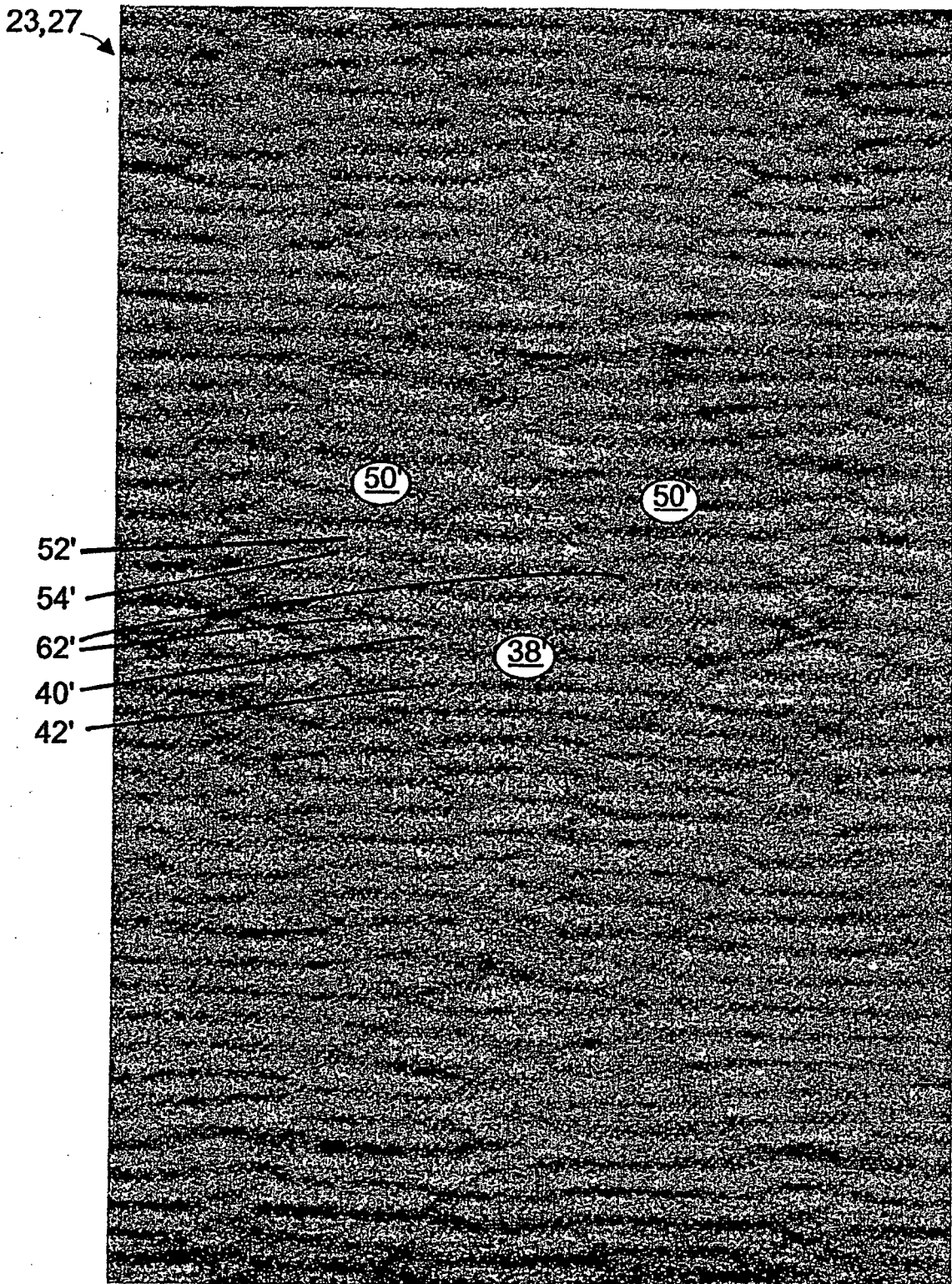

FIGURE 29

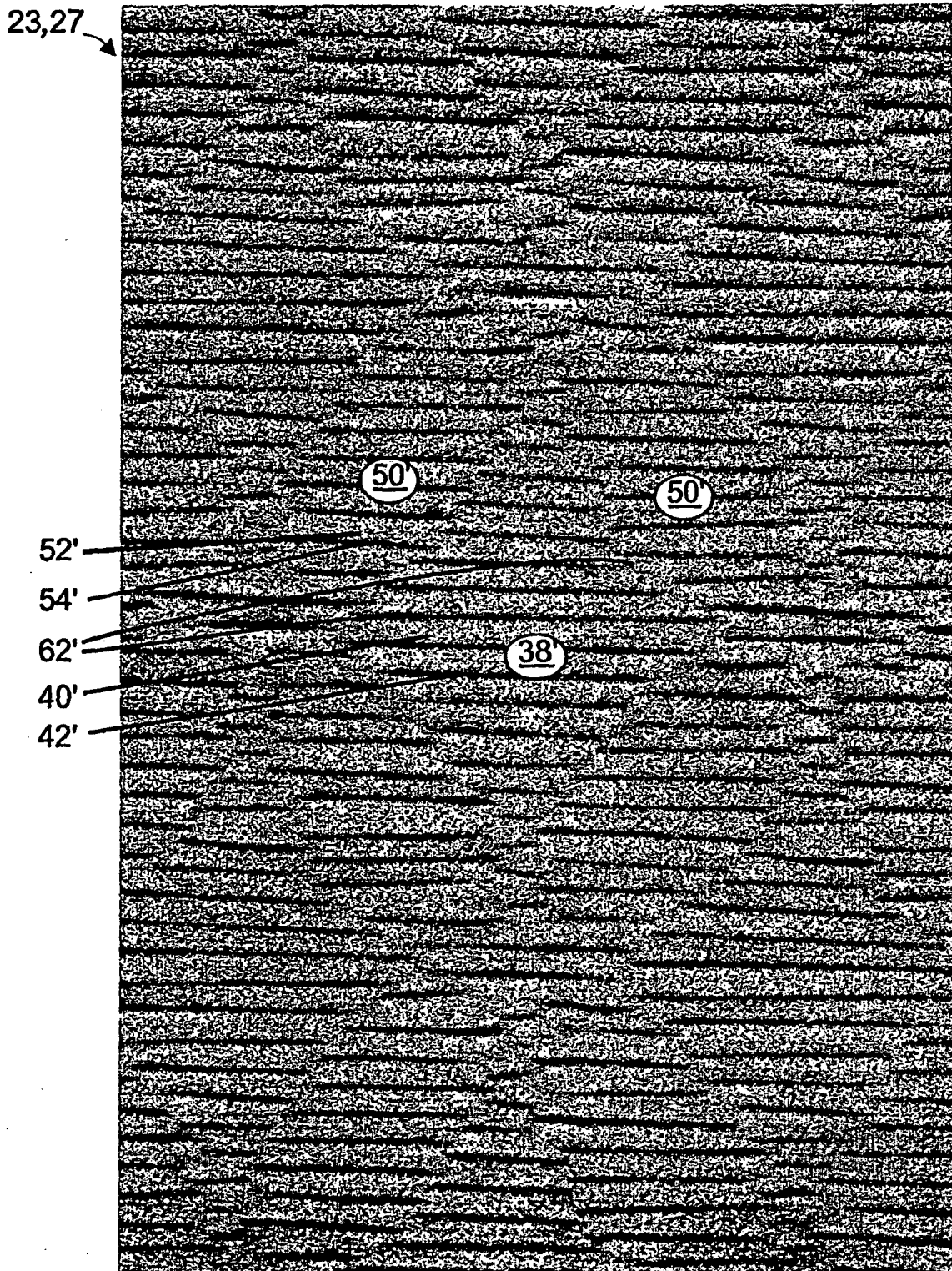

FIGURE 30

REFERENCES CITED IN THE DESCRIPTION

This list of references cited by the applicant is for the reader's convenience only. It does not form part of the European patent document. Even though great care has been taken in compiling the references, errors or omissions cannot be excluded and the EPO disclaims all liability in this regard.

Patent documents cited in the description

- US 5672248 A, Wendt [0002] [0011] [0011]
- US 4637859 A, Trokhan [0002] [0107]
- US 4967805 A, Chiu [0004]
- US 5328565 A, Rasch [0004] [0029]
- US 5820730 A, Phan [0004] [0035]
- WO 0063489 A [0006]
- EP 1109969 A1 [0020]
- US 5656132 A, Farrington [0029]
- US 6017417 A, Wendt [0029]
- US 5429686 A, Chiu [0029] [0123]
- US 5855739 A, Ampulski [0029]
- US 5897745 A, Ampulski [0029]
- US 5893965 A, Trokhan [0029]
- US 5972813 A, Polat [0029]
- US 5503715 A, Trokhan [0029]
- US 5935381 A, Trokhan [0029]
- US 4529480 A, Trokhan [0029]
- US 4514345 A, Johnson [0029] [0107]
- US 4528239 A, Trokhan [0029] [0107]
- US 5098522 A, Smurkoski [0029]
- US 5260171 A, Smurkoski [0029]
- US 5275700 A, Trokhan [0029]
- US 5334289 A, Trokhan [0029] [0107]
- US 5431786 A, Rasch [0029]
- US 5496624 A, Stelljes, Jr [0029]
- US 5500277 A, Trokhan [0029]
- US 5514523 A, Trokhan [0029]
- US 5554467 A, Trokhan [0029]
- US 5566724 A, Trokhan [0029]
- US 5624790 A, Trokhan [0029]
- US 6010598 A, Boutilier [0029]
- US 5628876 A, Ayers [0029]
- US 4919877 A, Parsons [0037]
- US 5667636 A, Engel [0039]
- US 5830321 A, Lindsay [0039]
- US 4440597 A, Wells [0039] [0041]
- US 4551199 A, Weldon [0039]
- US 4849054 A, Klowak [0039]
- US 5178729 A, Janda [0041]
- US 6103060 A, Munerelle [0041]
- US 6096169 A, Hermans [0041]
- US 6197154 B, Chen [0041]
- US 6143135 A, Hada [0041]
- US 5353521 A, Orloff [0041]
- US 5598642 A, Orloff [0041]
- US 5598643 A [0041]
- US 5701682 A [0041]
- US 5699626 A [0041]
- US 5871763 A, Luu [0041]
- US 5716692 A, Warner [0041]
- US 5573637 A, Ampulski [0041]
- US 5607980 A, McAtee [0041]
- US 5614293 A, Krzysik [0041]
- US 5643588 A, Roe [0041]
- US 5650218 A, Krzysik [0041]
- US 5990377 A, Chen [0041]
- US 5227242 A, Walter [0041]
- US 3879257 A [0041]
- US 5885418 A [0041]
- US 6149768 A [0041]
- US 5885416 A, Marinack [0041]
- US 5069548 A [0084]
- US 5679222 A, Rasch [0107]
- US 6120642 A, Lindsay and Burazin [0107] [0108]
- WO 09705684 A [0107] [0110]
- WO 09706149 A, Lindsay [0107] [0110]

Non-patent literature cited in the description

- **SABUT ADANUR.** Paper Machine Clothing. Technical Publishing, 1997, 33-113139-148159-168211-229 [0006]
- **J.D. LINDSAY.** Displacement Dewatering To Maintain Bulk. *Paperi Ja Puu*, 1992, vol. 74 (3), 232-242 [0041]
- **L. BIEMAN ; K. HARDING ; A. BOEHNLEIN.** Absolute Measurement Using Field-Shifted Moiré. *SPIE Optical Conference Proceedings*, 1991, vol. 1614, 259-264 [0083] [0084]
- **L. MUMMERY.** Surface Texture Analysis: The Handbook. Hommelwerke GmbH, 1990 [0089]