



US00D685155S

(12) **United States Design Patent**
Budde et al.

(10) **Patent No.:** **US D685,155 S**

(45) **Date of Patent:** **** Jun. 25, 2013**

(54) **FINANCIAL TRANSACTION MACHINE**

(56) **References Cited**

(75) Inventors: **William Budde**, Dublin, OH (US);
Giancarlo Miranda, Columbus, OH (US); **Joseph Bradley Nolan**, New Albany, OH (US); **Katherine Dill**, San Francisco, CA (US); **Alison Maiorano**, San Francisco, CA (US); **William Koehler**, San Francisco, CA (US); **Anthony Meredith**, San Francisco, CA (US); **Jonathan Rowell**, San Francisco, CA (US); **Howard Nuk**, San Francisco, CA (US); **David Scott**, Belmont, CA (US); **Tanya Khakbaz**, San Francisco, CA (US); **Charles Ambler**, San Francisco, CA (US); **Hanna Wickholm**, San Francisco, CA (US)

U.S. PATENT DOCUMENTS

D282,305 S 1/1986 Kusenberg
4,617,457 A 10/1986 Granzow et al.
D289,215 S 4/1987 Prinzhorn

(Continued)

Primary Examiner — Elizabeth J Oswecki
(74) *Attorney, Agent, or Firm* — Hunton & Williams LLP

(57) **CLAIM**
We claim the ornamental design for a financial transaction machine, as shown and described.

(73) Assignee: **JPMorgan Chase Bank, N.A.**, New York, NY (US)

DESCRIPTION

(**) Term: **14 Years**

(21) Appl. No.: **29/405,268**

FIG. 1 is a front perspective view of a first embodiment of a financial transaction machine showing our new design; FIG. 2 is a front elevational view of FIG. 1; FIG. 3 is a back elevational view of FIG. 1; FIG. 4 is a left side elevational view of FIG. 1; FIG. 5 is a right side elevational view of FIG. 1; FIG. 6 is a top plan view of FIG. 1; FIG. 7 is a bottom plan view of FIG. 1; FIG. 8 is a front perspective view of a financial transaction machine in FIG. 1 in a used condition with unclaimed environmental structure; FIG. 9 is a front perspective view of a second embodiment of a financial transaction machine showing our new design; FIG. 10 is a front elevational view of FIG. 9; FIG. 11 is a back elevational view of FIG. 9; FIG. 12 is a left side elevational view of FIG. 9; FIG. 13 is a right side elevational view of FIG. 9; FIG. 14 is a top plan view of FIG. 9; FIG. 15 is a bottom plan view of FIG. 9; and, FIG. 16 is a front perspective view of a financial transaction machine in FIG. 9 in a used condition with unclaimed environmental structure. The broken lines in the drawings illustrate environmental structure on the article and form no part of the claimed design.

(22) Filed: **Oct. 31, 2011**

(51) **LOC (9) Cl.** **20-01**

(52) **U.S. Cl.**
USPC **D99/28**

(58) **Field of Classification Search**
USPC D99/28, 34, 35, 36, 43, 99; D14/300-303, D14/900-902; D18/3.1-3.3, 4.1-4.6, 12.1-12.3; 206/0.8, 0.81, 0.815, 0.82, 0.83, 0.84; 101/66; 109/1 R, 1 V, 2, 23, 24.1, 25, 58, 58.5, 66; 446/8-13; 705/16, 17, 18, 42, 43, 44, 45

See application file for complete search history.

1 Claim, 14 Drawing Sheets

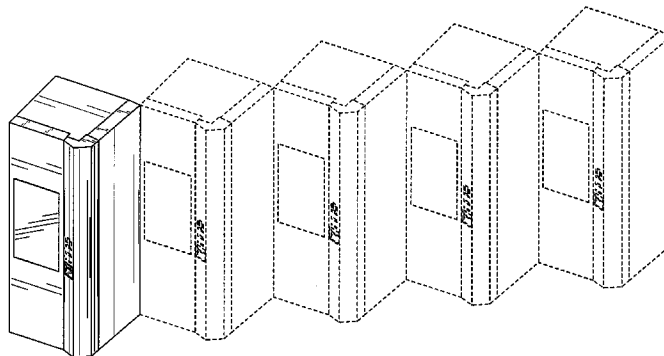
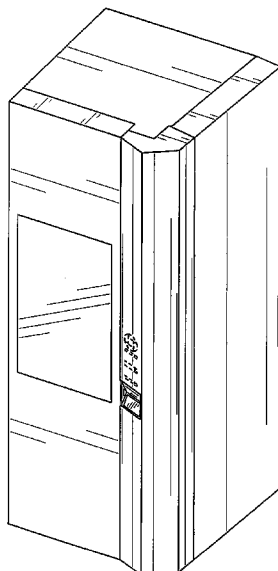

The broken lines in the drawings illustrate environmental structure on the article and form no part of the claimed design.

US D685,155 S

Page 2

U.S. PATENT DOCUMENTS

D293,150 S	12/1987	Prinzhorn		D425,875 S *	5/2000	Wilson	D14/307
D308,670 S *	6/1990	Hanson et al.	D432,755 S *	10/2000	Perkitny et al.	D99/34
D316,707 S *	5/1991	Allgeier	6,149,046 A	11/2000	Ho et al.		
5,025,139 A	6/1991	Halliburton, Jr.		6,536,663 B1	3/2003	Lozier et al.		
D360,734 S	7/1995	Hall		6,554,184 B1	4/2003	Amos		
D360,735 S	7/1995	Hall		6,554,185 B1	4/2003	Montross et al.		
D360,739 S	7/1995	Hall		6,796,490 B1	9/2004	Drummond et al.		
5,482,139 A	1/1996	Rivalto		6,874,612 B1	4/2005	Uland		
5,513,117 A	4/1996	Small		7,039,600 B1	5/2006	Meek et al.		
5,526,615 A	6/1996	Kaizu et al.		7,379,896 B1	5/2008	Meek et al.		
D375,607 S	11/1996	Hall		D585,943 S *	2/2009	Pymm et al.	D20/10
5,619,558 A	4/1997	Jheeta		D639,800 S *	6/2011	Magruder	D14/307
5,705,798 A	1/1998	Tarbox		D646,269 S *	10/2011	Crick et al.	D14/307
5,721,781 A	2/1998	Deo et al.		D665,555 S *	8/2012	Lee et al.	D99/28
5,897,625 A	4/1999	Gustin et al.		2002/0124271 A1 *	9/2002	Herrmann et al.	725/151
5,915,246 A	6/1999	Patterson et al.		2002/0133461 A1	9/2002	Ramachandran		
6,006,988 A	12/1999	Behrmann et al.		2003/0040959 A1	2/2003	Fei et al.		
6,045,039 A	4/2000	Stinson et al.						

* cited by examiner

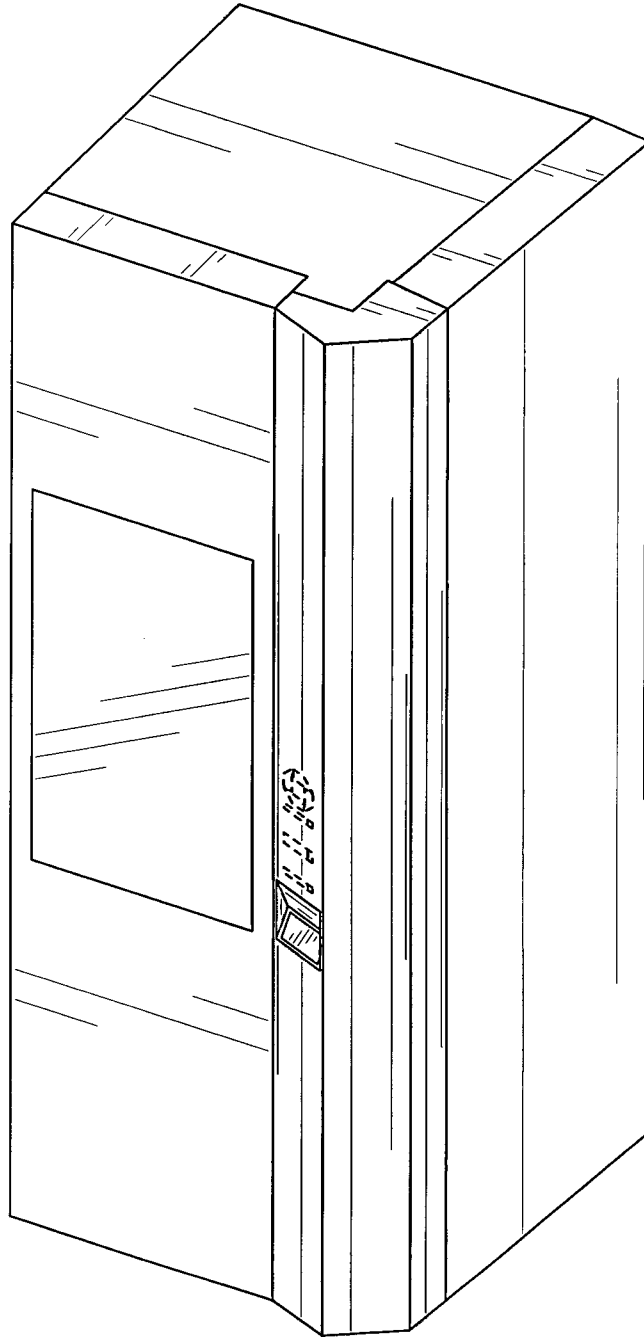

FIG. 1

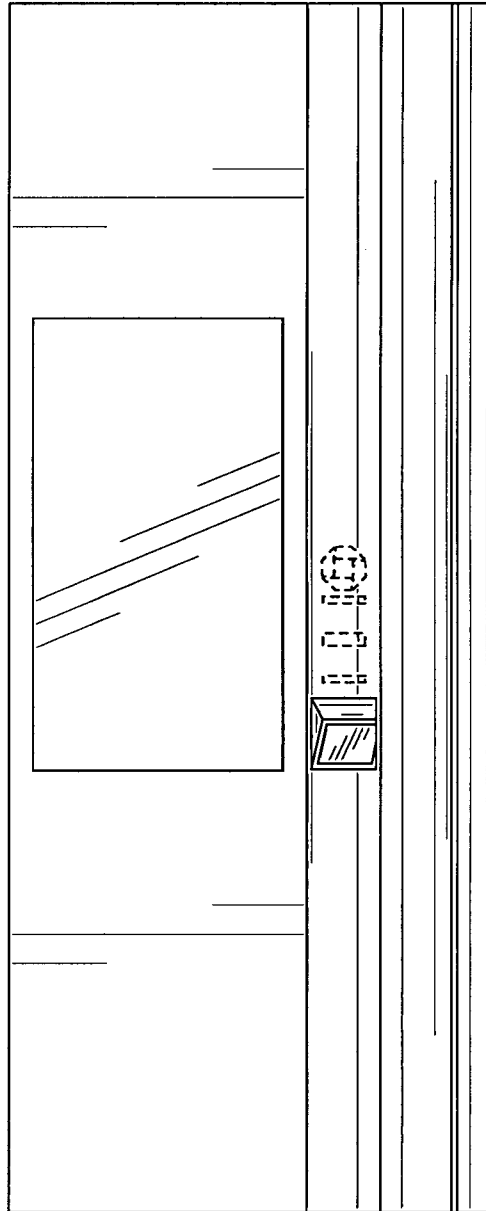

FIG. 2

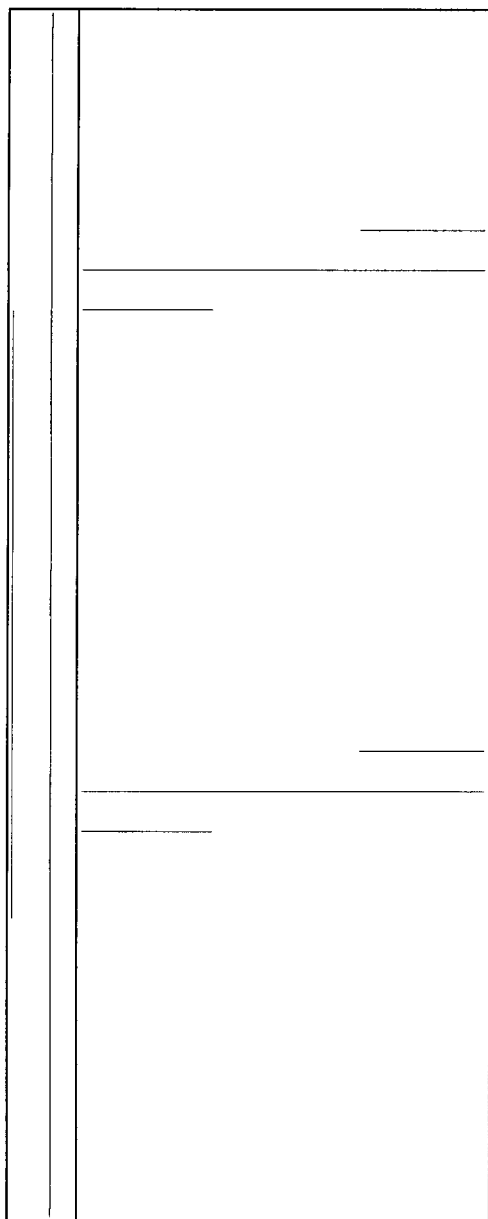

FIG. 3

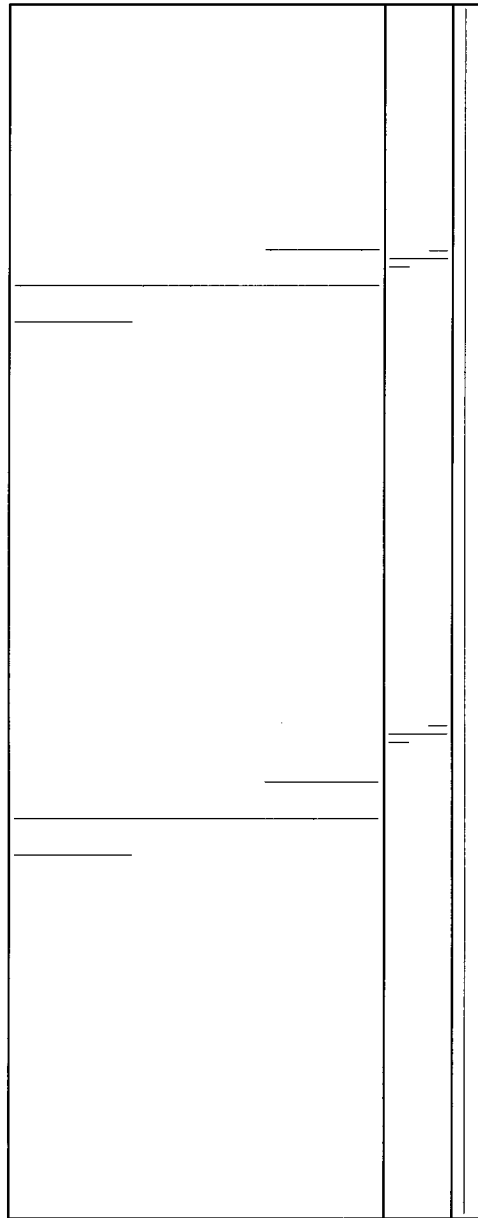

FIG. 4

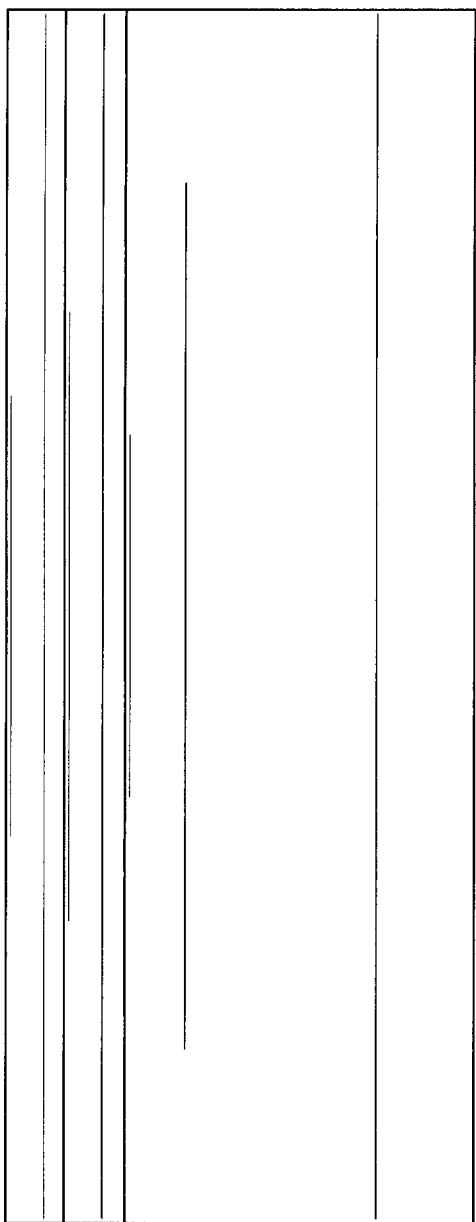

FIG. 5

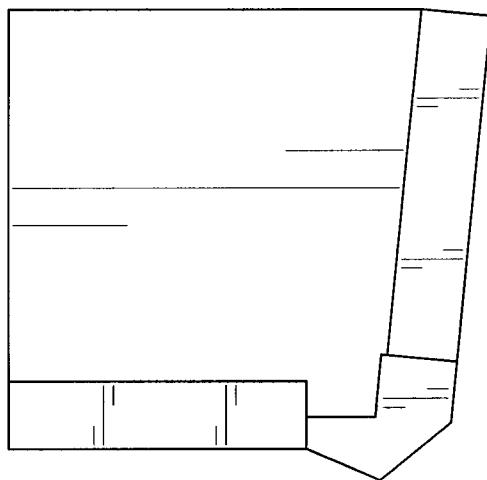

FIG. 6

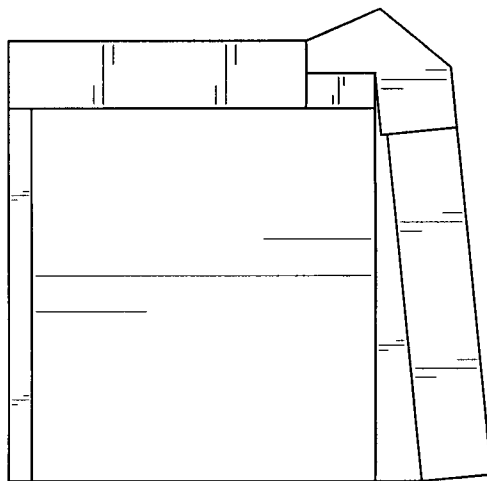

FIG. 7

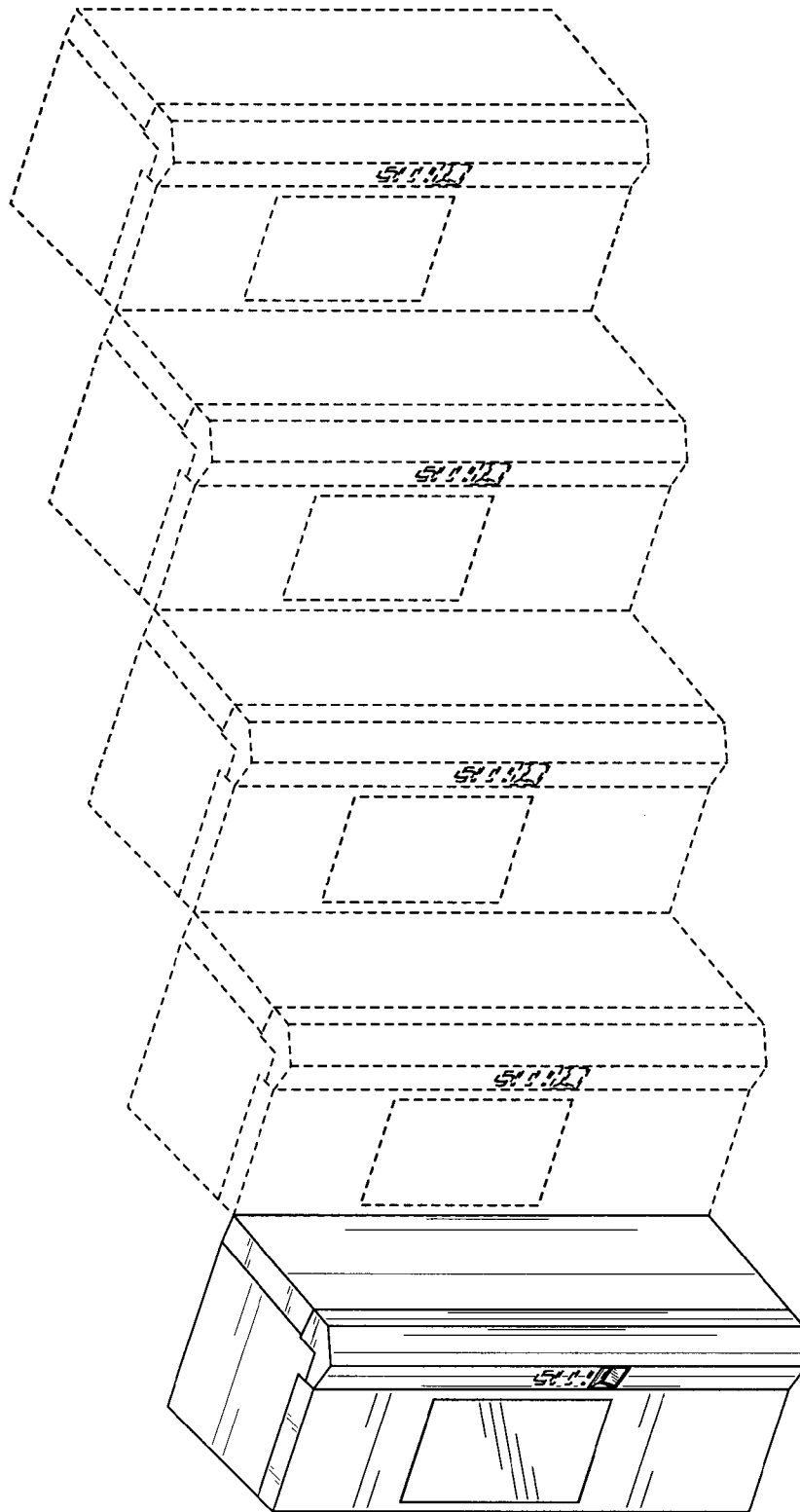

FIG. 8

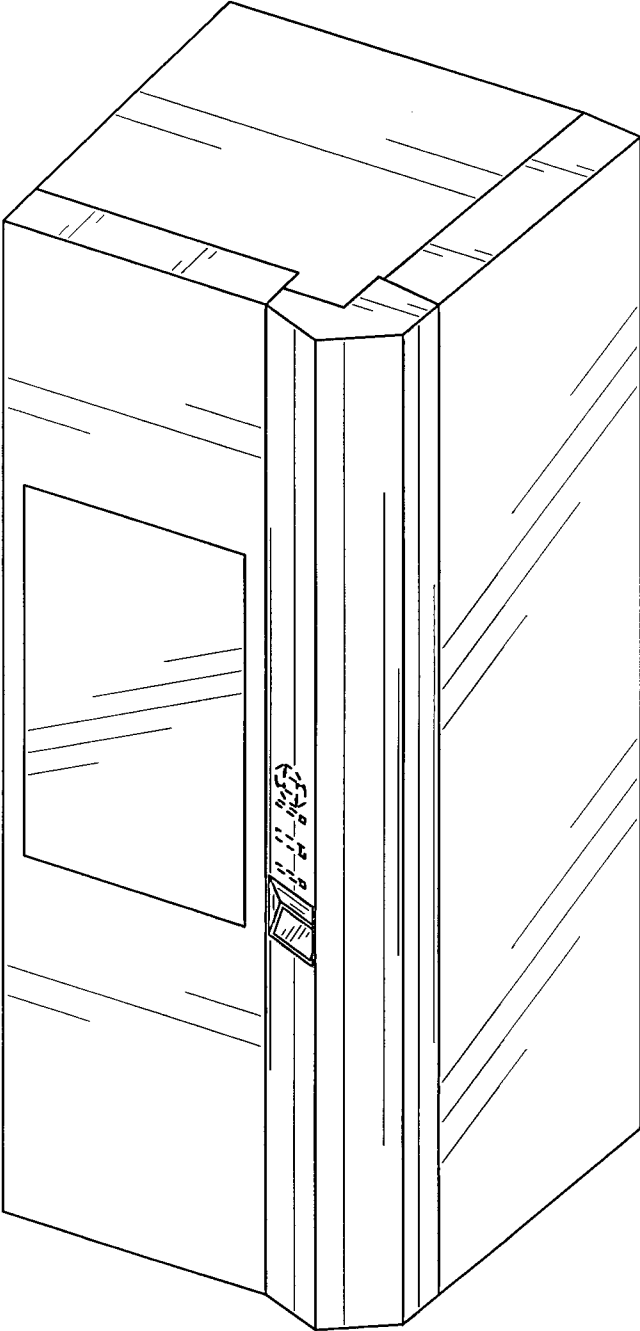

FIG. 9

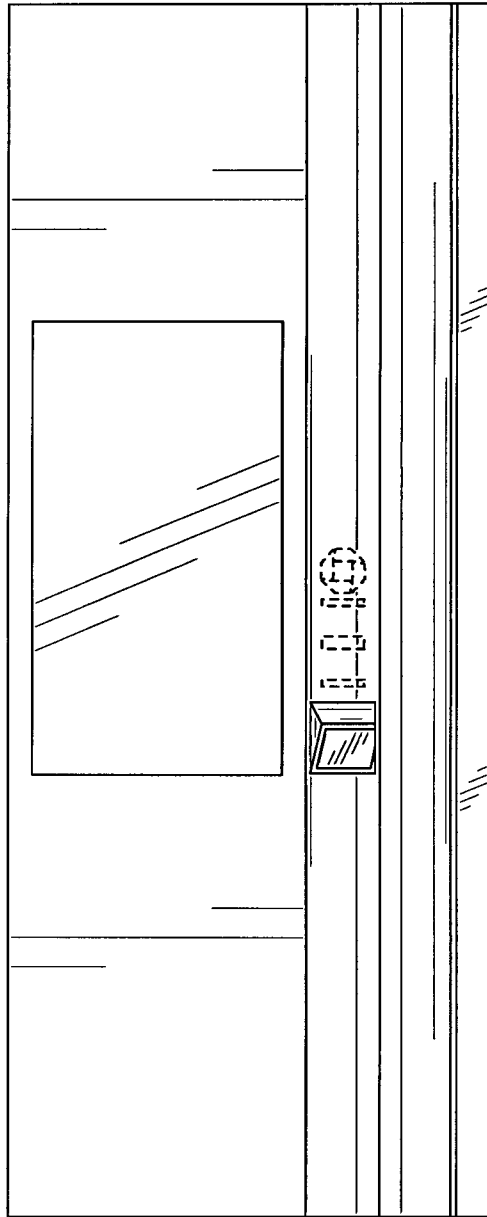

FIG. 10

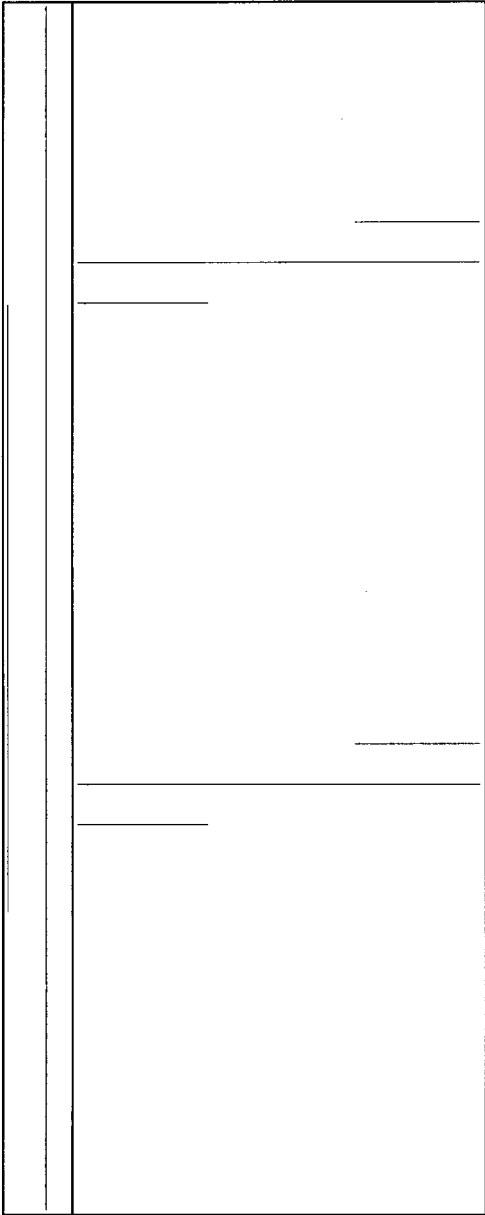

FIG. 11

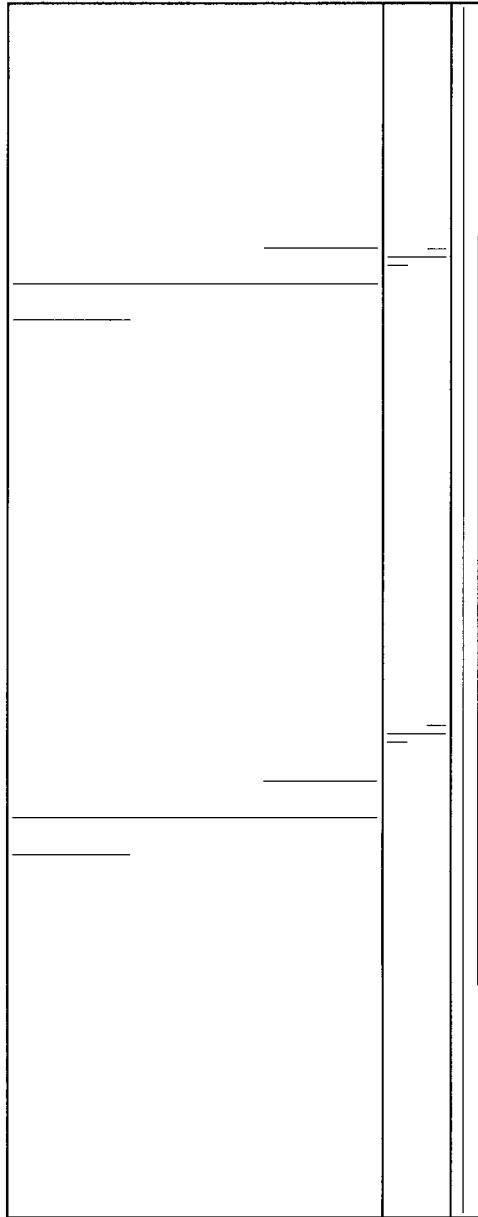

FIG. 12

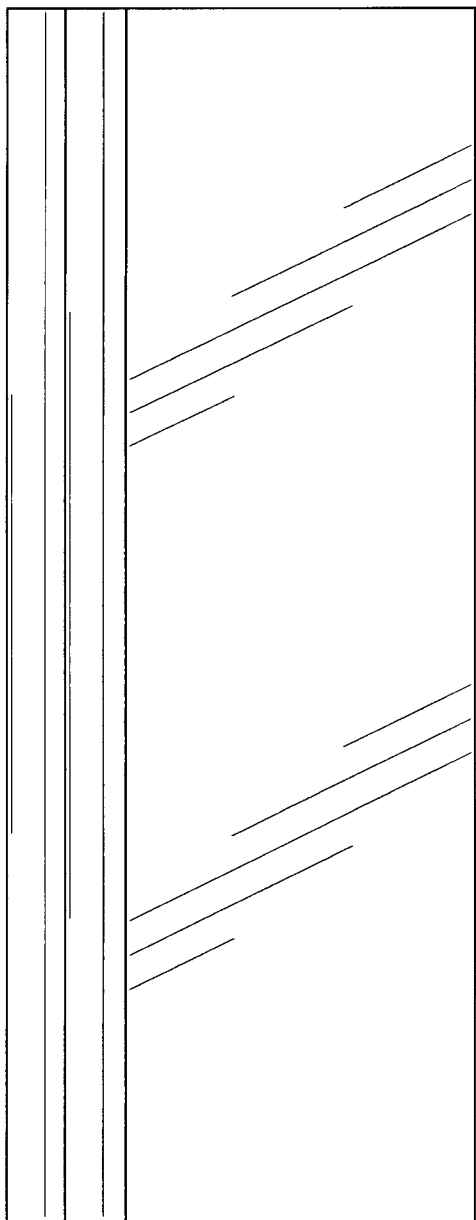

FIG. 13

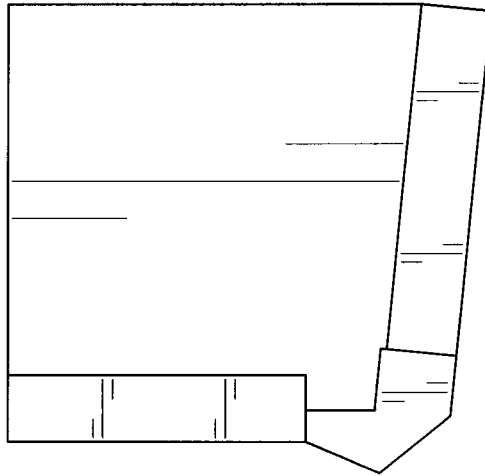

FIG. 14

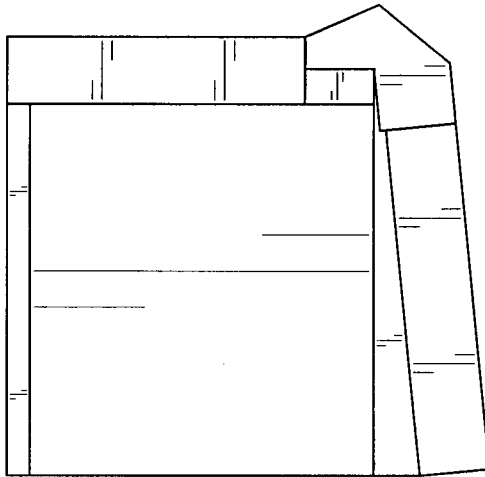

FIG. 15

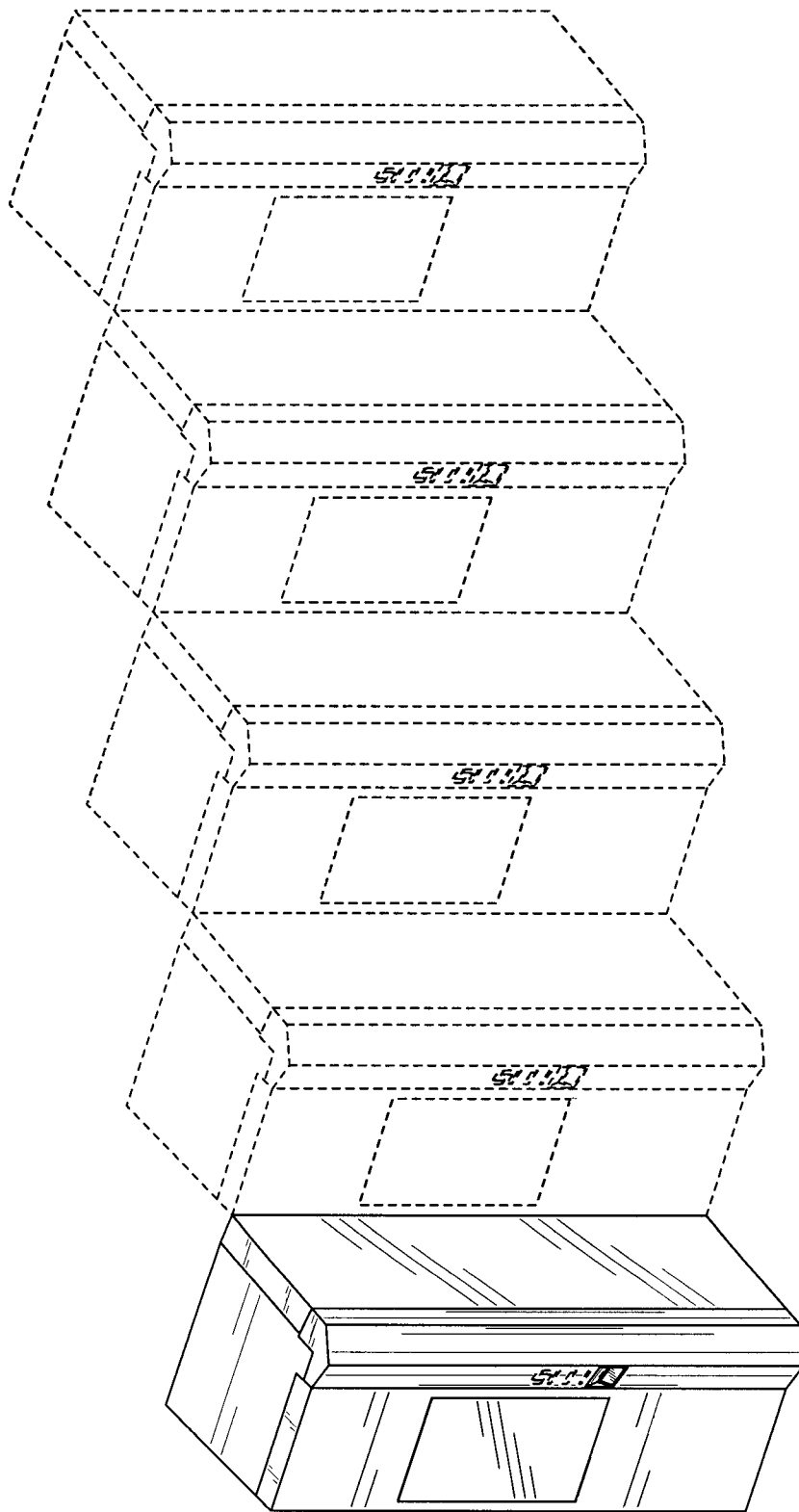

FIG. 16