

(No Model.)

G. T. MANSON.
JOINT FOR ELECTRIC CONDUCTORS.

No. 457,865.

Patented Aug. 18, 1891.

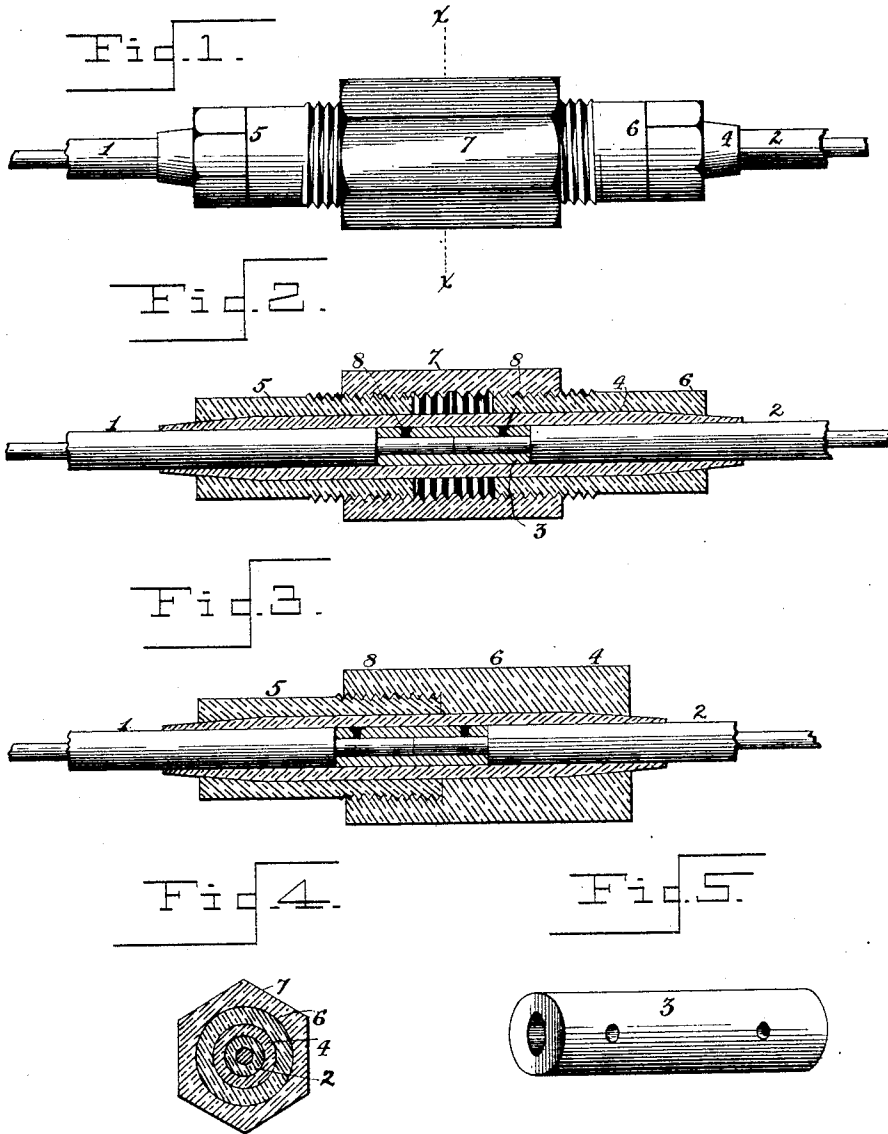

Witnesses
W. F. Cautland
& C. Ligg.

Inventor
George T. Manson
by Read Robinson
his Atty.

UNITED STATES PATENT OFFICE.

GEORGE THOMAS MANSON, OF BROOKLYN, NEW YORK.

JOINT FOR ELECTRIC CONDUCTORS.

SPECIFICATION forming part of Letters Patent No. 457,865, dated August 18, 1891.

Application filed April 1, 1891. Serial No. 387,248. (No model.)

To all whom it may concern:

Be it known that I, GEORGE THOMAS MANSON, a citizen of the United States, residing at Brooklyn, in the county of Kings and State of New York, have invented certain new and useful Improvements in Means for Protecting Joints in Electric Conductors; and I do hereby declare the following to be a full, clear, and exact description of the invention, such as will enable others skilled in the art to which it appertains to make and use the same.

This invention relates to devices for protecting joints of insulated electric conductors, the object being to make a quick and electrically efficient connection and effectually prevent the entrance of moisture to the joint.

The invention comprises, broadly, a sleeve of compressible material to surround the conductors at or near the joint, and two rigid tubular clamping devices adapted to be drawn together endwise by means of a screw, the pressure upon the compressible sleeve increasing. These tubes are drawn together until the sleeve is compressed to a degree at which it will be impossible for moisture to enter.

The several features of the invention will be more particularly defined in the claims appended to this specification.

In the accompanying drawings, which illustrate this invention, Figure 1 is a side elevation of the conductor to which my improvements have been applied. Fig. 2 is a horizontal sectional view of Fig. 1 on a central line, the conductors being shown in elevation. Fig. 3 is a sectional view of a modification. Fig. 4 is a cross-sectional view of Fig. 1, taken on the line xx . Fig. 5 is a perspective view of the metallic sleeve used to couple the bared ends of the conductors.

1 and 2 represent two conductors between which it is desired to establish an efficient moisture-proof joint. The ends of the conductors are bared for a short distance sufficient to make a snug fit between the adjoining portions of the insulating-cover and a copper tube 3, which is used for establishing the connection. After baring the conductors, a soft-rubber sleeve 4 and the clamping-tubes 5 6 7 are slipped over the end of one of the conductors. The copper sleeve 3 is then

placed over the bared ends and fastened by set-screws 8, or by means of a few drops of solder, thus establishing a reliable electric connection between the joined conductors. The elastic sleeve 4 is then shifted over the joint. This sleeve is made tapering at its ends and co-operates with two tubular clamps 5 6, provided with tapering shoulders on the outer ends. The inner ends of these clamps are screw-threaded with right and left handed threads, respectively, and co-operate with a nut 7, provided with internal threads, to draw the clamping-tubes together. The nut and clamping-tubes are both preferably made of insulating material—such as hard rubber—though they might be constructed of metal, inasmuch as they are perfectly insulated from the joint by means of a soft-rubber tube 4. The nut 7 and the tubes 5 6 are provided with a polygonal contour, so that they may be readily manipulated by hand or by a wrench to draw the tubes together horizontally and tighten the elastic tube.

It will be readily understood from inspection of Fig. 2 that as the clamping-tubes 5 6 are drawn together their internal shoulders, co-operating with the inclined ends of the soft-rubber tube, will firmly crowd the latter into close engagement with the insulating-covering of the conductors, and by drawing them together with a hard pressure a thoroughly water-tight connection is made and the joint will be securely protected.

In Fig. 3 a modification is shown in which the clamping-tubes screw into one another, and the nut is dispensed with. These tubes will be given a polygonal contour at the ends similar to the tubes 5 6 of Fig. 1, so that they may be screwed together. Otherwise the joint is established in the same manner as described in connection with Figs. 1 and 2. The copper sleeve is not absolutely essential to the establishment of the joint, as the two abutting ends of the conductor might be soldered together and wrapped with tape to fill out the space into alignment with the insulation of the conductors, thereby preventing the elastic tube from buckling when the clamping-tubes are drawn together.

While I prefer to use as the material from which the tube 4 is made soft rubber or similar elastic or compressible material, it is evi-

dent that an inelastic compressible material might be used, the desideratum being that the tube shall be capable of compression around the insulation of the conductors when the clamping-tubes are brought together longitudinally.

Having thus described my invention, what I claim as new, and desire to secure by Letters Patent, is—

10 1. As a means of protecting joints in electric conductors, an elastic tube surrounding the insulation of the conductors on both sides of the joint, and clamping devices for compressing said elastic tube into water-tight engagement with the insulation.

15 2. As a means of protecting joints in electric conductors, a compressible tube surrounding the insulation of the conductors on both sides of the joint, and clamping devices for compressing said tube into water-tight engagement with the insulation.

25 3. As a means of protecting joints in electric conductors, a tube surrounding said conductors at the joint, said tube tapering and being compressible at its ends, clamping-tubes provided with a tapering bore co-operating with the tapering ends, and means for drawing the clamping-tubes together.

30 4. As a means of protecting joints in electric conductors, the combination of the compressible tube 4, provided with tapering ends, clamping-tubes 5 6, provided with co-operating tapering internal surfaces, and means for drawing the clamping-tubes together.

35 5. As a means of protecting joints in electric conductors, the combination of an elastic tube 4, provided with tapering ends, an in-

ternal bore to suit the conductors to be connected, a filling material around the joint of the bared conductor, clamping-tubes 5 6, and means for drawing the clamping-tubes together.

6. As a means of protecting joints in electric conductors, the combination of the metallic tube 3 surrounding the bared ends of the conductors to be connected, elastic tube 4, tapering at its ends and inclosing the joint, clamping-tubes 5 and 6, and means for drawing the clamping-tubes together.

7. As a means of protecting joints in electric conductors, the combination of the elastic tube tapering at its ends surrounding the conductors on both sides of the joint, threaded clamping-tubes 5 6, and co-operating nut 7, internally threaded with right and left handed screw-threads, as and for the purpose described.

8. As a means of protecting joints in electric conductors, the combination of the elastic tube tapering at its ends surrounding the conductors on both sides of the joint, threaded clamping-tubes 5 6, and co-operating nut 7, internally threaded with right and left handed screw-threads, the clamping-tubes and nut being provided with a polygonal contour to facilitate their manipulation, as and for the purpose described.

In testimony whereof I affix my signature in presence of two witnesses.

GEORGE THOMAS MANSON.

Witnesses:

E. C. GRIGG,
VICTOR E. BURKE.