

E. G. LEWIS.  
ADDRESSING MACHINE.  
(Application filed Dec. 4, 1899.)

(No Model.)

2 Sheets—Sheet 1.

*Fig. 1.*

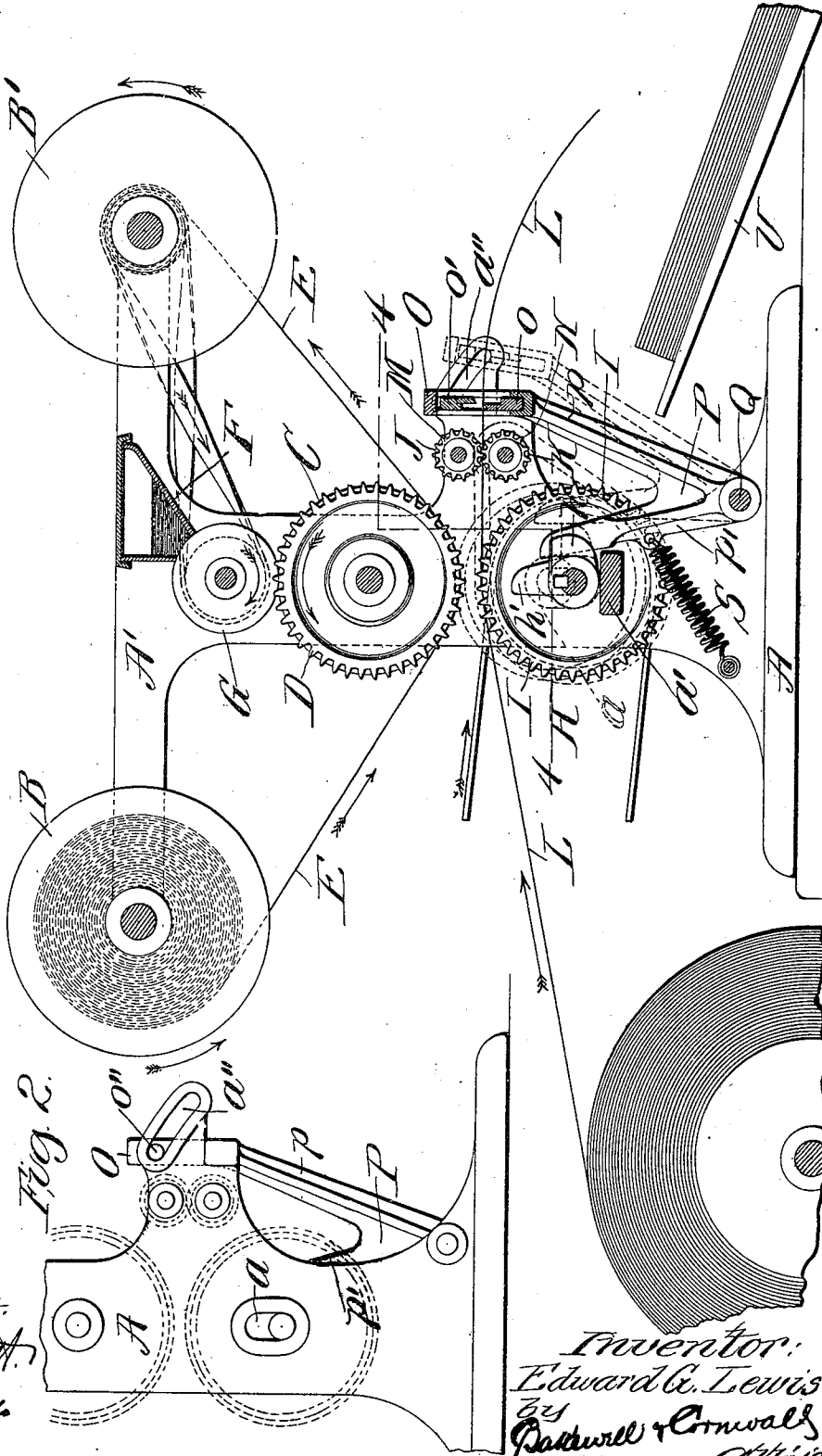

*Fig. 2.*

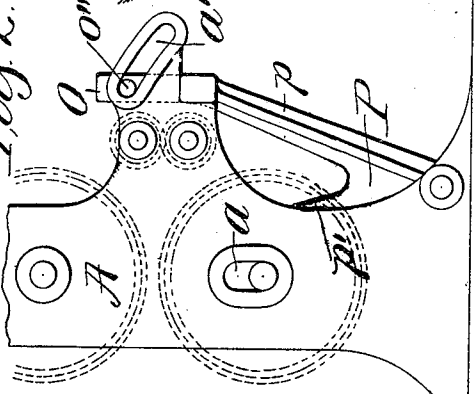

*Attest:*  
*Wm. R. Frost*  
*A. B. Gray*

*Inventor:*  
*Edward G. Lewis*  
*By*  
*Rathwell & Cornwall*  
*Attorneys*

E. G. LEWIS.  
ADDRESSING MACHINE.

(Application filed Dec. 4, 1899.)

(No. Model.)

2 Sheets—Sheet 2.

FIG. 4.

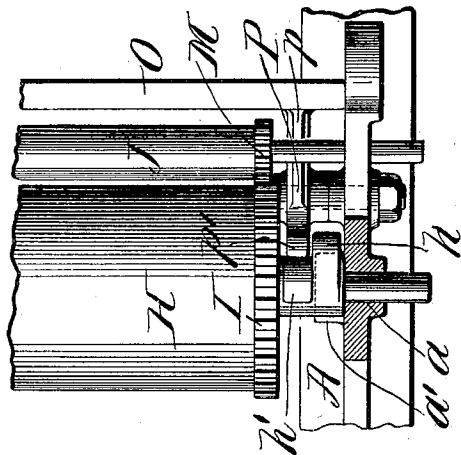
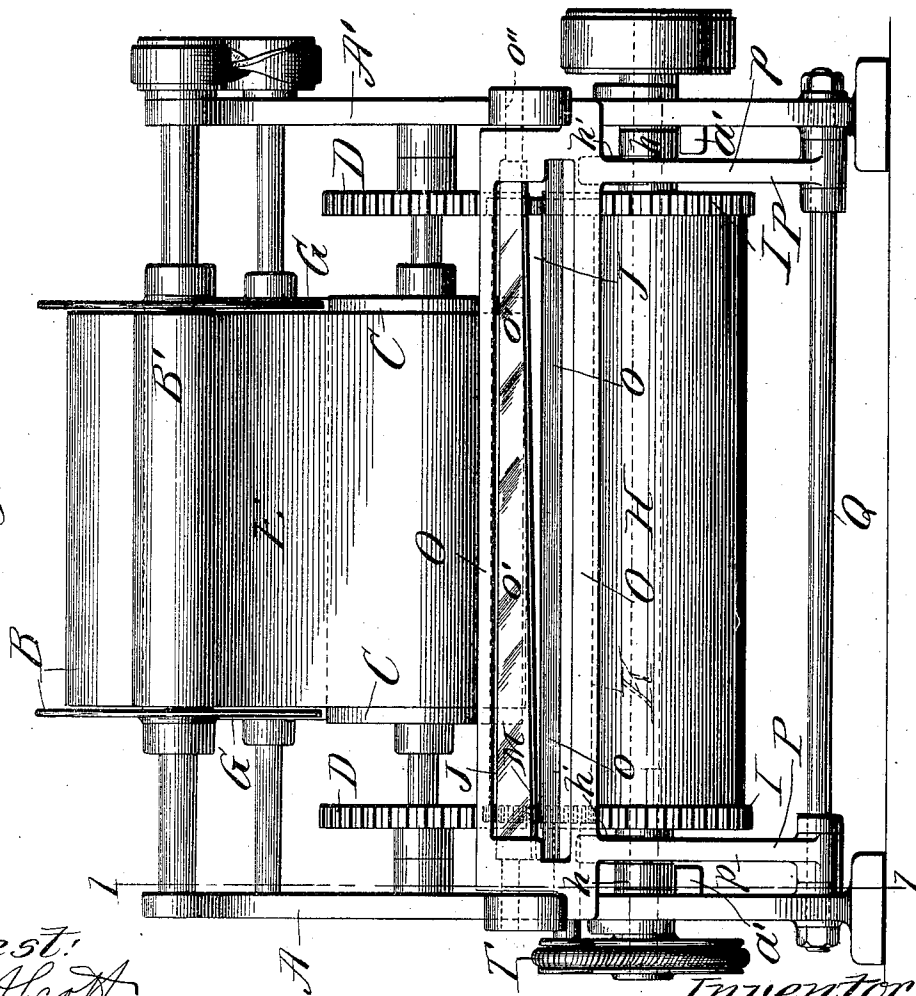

FIG. 3.



Attest:  
*J. M. Aycott.*  
*A. S. Gray.*

Inventor:  
*Edward G. Lewis.*  
*W. B. Kewell Cornwall*  
*Attys*

# UNITED STATES PATENT OFFICE.

EDWARD G. LEWIS, OF ST. LOUIS, MISSOURI.

## ADDRESSING-MACHINE.

SPECIFICATION forming part of Letters Patent No. 654,263, dated July 24, 1900.

Application filed December 4, 1899. Serial No. 739,114. (No model.)

*To all whom it may concern:*

Be it known that I, EDWARD G. LEWIS, a citizen of the United States, residing at the city of St. Louis, State of Missouri, have invented a certain new and useful Improvement in Addressing-Machines, of which the following is a full, clear, and exact description, such as will enable others skilled in the art to which it appertains to make and use the same, reference being had to the accompanying drawings, forming part of this specification.

This invention relates to a new and useful improvement in an addressing-machine for printing or impressing upon a web of paper or other suitable material inscriptions from a film web through the instrumentality of an ink-roll and then automatically cutting the printed paper web into suitable sheets of a desired length.

The object of this invention is to provide a simple, cheap, and practical machine which will print upon a web of paper an inscription—such, for instance, as the name and post-office address of a person—and then automatically feed the web of paper a suitable distance and cut it off.

The essential features of this invention reside, first, in the novel construction and arrangement of the printing-film web; second, in the novel construction and arrangement of the automatic intermittent feed therefor; third, in the novel construction and arrangement of the paper-web feed; fourth, in the novel construction and arrangement of the cutting mechanism, and, finally, the invention consists in the novel construction and arrangement of the several parts of the device, all as will be more fully explained, and afterward pointed out in the claims.

I attain the objects before referred to by the mechanism illustrated in the accompanying drawings, in which—

Figure 1 is a vertical sectional view of my improved printing and cutting machine, the same being taken on the indicated line 1 1 of Fig. 3. Fig. 2 is a side elevational view of one portion of the same. Fig. 3 is a front elevational view of the same, and Fig. 4 is a horizontal sectional view of the same on the line 4 4 of Fig. 1.

Similar characters refer to similar parts throughout the several views.

In the drawings, A and A' represent suitable frames on which are mounted the component parts of my machine.

B and B' represent suitable reels or spools, suitably arranged and journaled in, preferably, the upper portion of the frames A and A'.

C represents a combined feed and inking roller, preferably arranged about midway the distance of and somewhat below the reels B and B', said roller being arranged between and suitably journaled in the frames A and A' and provided upon one or both of its ends with spur-gears D.

E represents a web or film which is wound upon the reels B and B', said web or film being so arranged that it passes under the feed and inking roller C, so that the lower surface of the inking-roller C is covered by said film.

F indicates an ink-fountain arranged in the upper portion of the frame of the machine and has arranged thereunder and in conjunction therewith a suitably-journaled ink-distributing roll G, which in turn coöperates and has peripheral contact with the combined feed and inking roller C.

The web or film E is formed of a suitable paper compound, such as is used in mimeograph-machines, and is possessed of that property which when properly acted upon by a suitable instrument or by the bare type-keys of a type-writer is so mutilated or semi-perforated that ordinary printer's ink or like ingredients when applied thereto by a roll or brush will cause some of said ink or ingredients to penetrate the mutilated or semi-perforated portion of the film and leave a legible impression upon paper or other material previously placed thereunder. However, as this film and its just-mentioned properties form no part of my present invention a more detailed description of the same will not be given.

H represents a platen-roller mounted on a suitable shaft, or, if desired, may be provided with stub shafts or trunnions at its ends, said shafts or trunnions finding bearings in the frames A and A' by being permitted to pass through suitable slots *a a*, formed

therein. This platen-roller is preferably of the same diameter as the roller C and is arranged therebeneath, and in its normal position is some little distance away from the same. It is provided upon its ends with spur-gears I, which are in vertical alinement with and designed to impart motion to the roller C when the constantly-rotating roller H is vertically adjusted, as will hereinafter be explained.

J and K represent feed-rollers mounted upon and journaled in the frame of the machine, the same being preferably vertically disposed with respect to each other and arranged or located about midway and in advance of the rollers C and H. One of these rollers is a constantly-driven roller, which rotates in a direction to effect the proper forward feed of a web of paper L, which passes between it and its companion, which companion is caused to rotate in the opposite direction, or the proper direction to assist said driven roller in its feed of said web, by suitable spur-gears M, which mesh with spur-gears N on the driven roller.

Inasmuch as it is desirable, if not necessary, to have the roller C rotate intermittently and the platen-roller to revolve continuously, I have provided means for accomplishing the same, which consists of a suitable cam *h*, arranged on the shaft or trunnion of roller H, and at a point directly beneath said cam and formed on the frame A of the machine is a projection *a'*, so arranged as to be in the path of the revolving cam *h*, and in order for said cam to pass said projection *a'* it is necessary for the roller H and its carried parts to rise, which it is capable of doing, as the bearings of the shaft of said roller are normally in the bottom of vertically-disposed slots *a*, before mentioned. This rising action of the continually-rotating roller H and its carried parts causes the spur-gears I, secured thereto, to mesh with the spur-gears D, secured to the roller C, and thus impart rotary motion to the same, said rotary motion, however, only lasting so long as the cam *h* is resting upon the projection *a'* of the frame, and when said cam *h* rides off of said projection the roller H of its own gravity will follow until its shaft rests upon the frame at the lower end of the slot *a*, which movement will bring the spur-gears I out of mesh with the spur-gears D and cause the roller C to stop rotating. The rising of the roller H and its gears I performs an additional function to that of providing an intermittent feed of the roller C, in that it forces the web of paper L, which passes between it and the roller C, up against the film web E, and acting as a platen causes legible impression to be imparted to the said web of paper. After effecting an impression on the web of paper L and feeding said web of paper into equal lengths or, rather, sever from the web a sheet bearing the impression, and inasmuch as the web of paper

is constantly being fed forwardly it follows that the knife employed should also move with the paper in order to prevent said paper from bending or crumpling, which would obviously be undesirable, and to accomplish the desired end I have provided adequate means, as follows: O represents a preferably rectangular skeleton frame designed to hold stationary and movable knives *o* and *o'*, respectively, said frame O being supported by one member *p* of a pair of bell-crank levers P P, which bell-crank levers are pivotally mounted upon a rod Q, secured at a suitable point to the frames A and A'. P' represents the other member of the bell-crank lever P, the free end of which is arranged in the path of cam *h'*, secured to the shaft of the roller H, which cam *h'* may be, if desired, formed integral with the cam *h*, but arranged at an angle thereto, as is illustrated in the drawings, it being obvious, however, that this cam can be formed independently.

The movable knife *o'* is provided upon its ends with a short cylindrical portion *o''*, which is designed to pass through slots *a''*, formed in the frames A and A', which slots *a''* are arranged eccentrically to the pivot-point of the bell-crank lever P, and by such eccentric relation of these slots *a''* relative to the pivot-point of said bell-crank lever the movable knife *o'* is held away from the stationary knife *o* while the web of paper L is being fed there-through, said knives and their component parts being held in such position through the instrumentality of a preferably coiled expandible spring S, one end of which is secured to the frame of the machine and the other to the bell-crank lever P.

The operation of the device just described is as follows: When it is desired to print or impress upon a web of paper the inscriptions on the film web E, the latter is wound upon the rear reel B of the machine, passed under the roller C, and then started upon the spindle of the forward reel B'. The roller C, which has been previously coated with ink from the fountain F through the instrumentality of the distributing-roller G, now presents a coat of ink to the upper face of the film E. The web of paper L is now passed over the platen-roller H and between the feed-rollers J and K and the knives *o* and *o'* and power then applied to the roller H, which power causes the same to rotate, and through the instrumentality of a belt T rotary motion in the same direction is imparted to the feed-roller K, which in turn rotates the roller J and effects the proper feed of the web of paper. When the roller H has made a portion of a revolution, the cam *h* is forced against the stationary projection *a'*, which action causes the roller H and its carried parts to move upwardly and force the web of paper L against the film E on the roller C, thereby causing the ink upon the roller C to be forced through the mutilated portion of said film onto the web of paper. Simultaneously with this action the

spur-gears on the roller H having been brought into mesh with the spur-gears on the roller C by the upward movement of the former, the roller C is caused to make a portion of a revolution the length of which is determined by the length of time the cam *h* is in contact with the stationary projection *a'* or by the number of degrees of a revolution it takes for the cam *h* to pass said projection. After this cam *h* has passed the projection *a'*, the roller H and its carried parts will of their own gravity fall away from the roller C, thus releasing the spur-gearing and permitting the roller C to stop rotating, the roller H and the feed-rollers J and K, however, continuing to rotate and feed the web of paper, and at the proper time the cam *h'* on the shaft of the roller H will cooperate with the member P' of the bell-crank lever P, forcing said bell-crank lever outwardly and slightly downwardly against the tension of the spring S, which movement of said bell-crank lever causes the movable knife which cooperates with the cam-slots *a''* of the frame of the machine to move toward the stationary knife and sever the web of paper. It will be understood that while the movable knife *o'* is moving toward the stationary knife both knives and their supports are moving in a direction with the travel of the web of paper, and the severing or cutting action takes place during such travel, thereby preventing the bending or crumpling of said paper. After a suitable length of paper has been cut from the web the same may be caused to fall upon a suitable support or shelf U or deposited into a box or basket, as desired.

The web of paper L is preferably drawn from a roll mounted upon a suitable reel located at any convenient place near the machine.

I am aware that minor changes in the arrangement, construction, and combination of several parts of my device can be made and substituted for those herein shown and described without in the least departing from the nature and principle of my invention.

Having thus described my invention, what I claim, and desire to secure by Letters Patent, is—

1. In a device of the character described, the combination with a continuous mutilated film, of spools or reels on which the same is wound, means for causing the intermittent feed of said mutilated film, an inking-roller under which said film passes for forcing ink or like ingredients through the mutilations of said film onto a web of paper to be printed upon, and means for effecting the continuous feed of said web of paper through the machine; substantially as described.

2. In a device of the character described, the combination with a continuous mutilated film, of means for intermittently feeding said film, a web of paper, means for continuously feeding said web of paper through the machine, an inking-roller cooperating with the film for forcing ink or like ingredients through

said mutilated film onto the web of paper, and mechanism for effecting contact of said web of paper with said film at intervals; substantially as described.

3. In a device of the character described, the combination with a frame, of reels mounted thereon, of an ink-roller, a mutilated film wound upon said reels and passing around one portion of said ink-roller, means for supplying ink to said ink-roller, means for intermittently feeding said mutilated film and its supporting-reels and its ink-roller, a web of paper, a platen-roller over which said web of paper passes, means for continuously feeding said web of paper, and means for forcing said platen-roller against said ink-roller, in order to cause said web of paper to be pressed against said mutilated film to make an impression on the former; substantially as described.

4. In a device of the character described, the combination with an ink-roller, of a spur-gear arranged thereon, a mutilated film which passes around one side of said ink-roller, a reel upon which said mutilated film is wound, a platen-roller, a spur-gear arranged thereon, said platen-roller and its carried spur-gear being normally out of contact with said ink-roller and its carried spur-gear, means for constantly rotating said platen-roller, a web of paper which passes over said platen-roller, means for continually feeding said web of paper, a cam arranged on said platen-roller, and a stationary projection arranged in the path of said cam, whereby, when said cam is brought into contact with said projection, the platen-roller and its carried parts are caused to move toward the ink-roller and cause the paper web to be pressed against the mutilated film to effect an impression and simultaneously cause the spur-gear on said platen-roller to mesh with the spur-gear on the ink-roller and cause the latter to rotate until the cam on the platen-roller passes the stationary projection, after which said platen-roller will fall to its normal position and cause its carried spur-gear to be brought out of mesh with the spur-gear on the ink-roller and permit the latter to cease rotating; substantially as described.

5. In a device of the character described, the combination with a supporting-frame having slots formed therein, of a platen-roller provided with trunnions which pass through said slots, a cam arranged on said platen-roller, a stationary projection in the path of rotation of said cam, a mutilated film arranged above said platen-roller, an inking device arranged on one side of said mutilated film, a web of paper which passes over said platen-roller, a roller for continuously feeding said web of paper, a lever pivotally mounted on said supporting-frame, means carried by said lever for supporting knives, a cam arranged on said platen-roller for cooperating with, and rocking, said lever, and means for causing said knives to sever a sheet of paper from the web

which passes in juxtaposition thereto; substantially as described.

5 6. The combination with a film having formed thereon mutilated characters, of a continuous web of paper, means for moving said continuous web constantly through the machine, devices for forcing ink or like ingredients through the mutilations of said film onto said continuous web, mechanism for inter-  
10 mittedly feeding said mutilated film, and knife or shear blades for severing the continuous web into predetermined lengths; substantially as described.

15 7. The combination with the main frame of a machine of the character described, of a shaft carrying an ink-roller, a mutilated film passing under said roller, a vertically-movable platen over which passes a continuous  
20 said vertically-movable platen, mechanism for intermittently raising and lowering said platen into and out of contact with the inking-roller, a supporting-frame secured to the main framing of the machine, a lever pivoted  
25 to said frame, a knife-frame carried by said lever, a cam arranged on the shaft of the vertically-movable platen-roller for rocking said lever, stationary and movable knives arranged in said knife-frame, and projections  
30 on the movable knife extending into slots in said supporting-frame, for effecting the movement of said movable knife; substantially as described.

8. The combination with mechanism for

35 constantly feeding a strip of paper to be printed upon, a printing-strip normally out of engagement with the strip of paper to be printed upon, inking devices cooperating with said strip, and mechanism for imparting an intermittent movement in the same direction as  
40 the movement of the strip to be printed upon and coincidentally with the period of printing contact; substantially as described.

9. The combination with mechanism for constantly feeding a continuous strip of paper, of a printing device in the form of a continuous strip arranged in juxtaposition thereto, and means for moving said printing-strip only during the period of printing contact; substantially as described. 50

10. The combination with mechanism for constantly feeding a continuous strip of paper, of a printing device in the form of a perforated sheet or strip in juxtaposition to said first-mentioned strip, and means for engaging the feeding mechanism with the printing mechanism, whereby said printing devices are moved in the direction of the impression-receiving strip during such time as the printing device is in proper position to make an  
60 impression; substantially as described.

In testimony whereof I hereunto affix my signature, in the presence of two witnesses, this 18th day of November, 1899.

EDWARD G. LEWIS.

Witnesses:

WM. H. SCOTT,  
A. S. GRAY.