



(19) **United States**

(12) **Patent Application Publication**
Eizen et al.

(10) **Pub. No.: US 2011/0154868 A1**

(43) **Pub. Date: Jun. 30, 2011**

(54) **APPARATUS FOR LOCKING GAS CANISTERS**

(52) **U.S. Cl. 70/164**

(75) **Inventors: Noach Eizen, Rishon Le Zion (IL); Eli Levy, Nir Zvi (IL)**

(73) **Assignee: HI-G-TEK INC.**

(57) **ABSTRACT**

(21) **Appl. No.: 12/745,063**

(22) **PCT Filed: Nov. 26, 2008**

(86) **PCT No.: PCT/IL08/01545**

§ 371 (c)(1),
(2), (4) **Date: Mar. 16, 2011**

A remotely monitorable selectably removable lock assembly for a fluid valve assembly of a bottled gas canister or other fluid valve assembly, the remotely monitorable, selectably removable, lock assembly including a lockable cover assembly configured for lockable engagement with a fluid valve assembly, a remote monitoring unit fixedly mounted to a locking shaft, arranged for lockable engagement with the lockable cover assembly when the lockable cover assembly is in a closed operative orientation, preventing unauthorized access to the fluid valve assembly and a locking unit which is operative for locking engagement with the locking shaft for retaining the cover assembly in the closed operative orientation, the remote monitoring unit having wireless communication functionality enabling it to communicate with a remote monitoring station for providing monitorable indications both of tampering and of authorized unlocking of the locking unit from the locking shaft.

Related U.S. Application Data

(60) **Provisional application No. 60/990,349, filed on Nov. 27, 2007.**

Publication Classification

(51) **Int. Cl. B65D 55/14 (2006.01)**

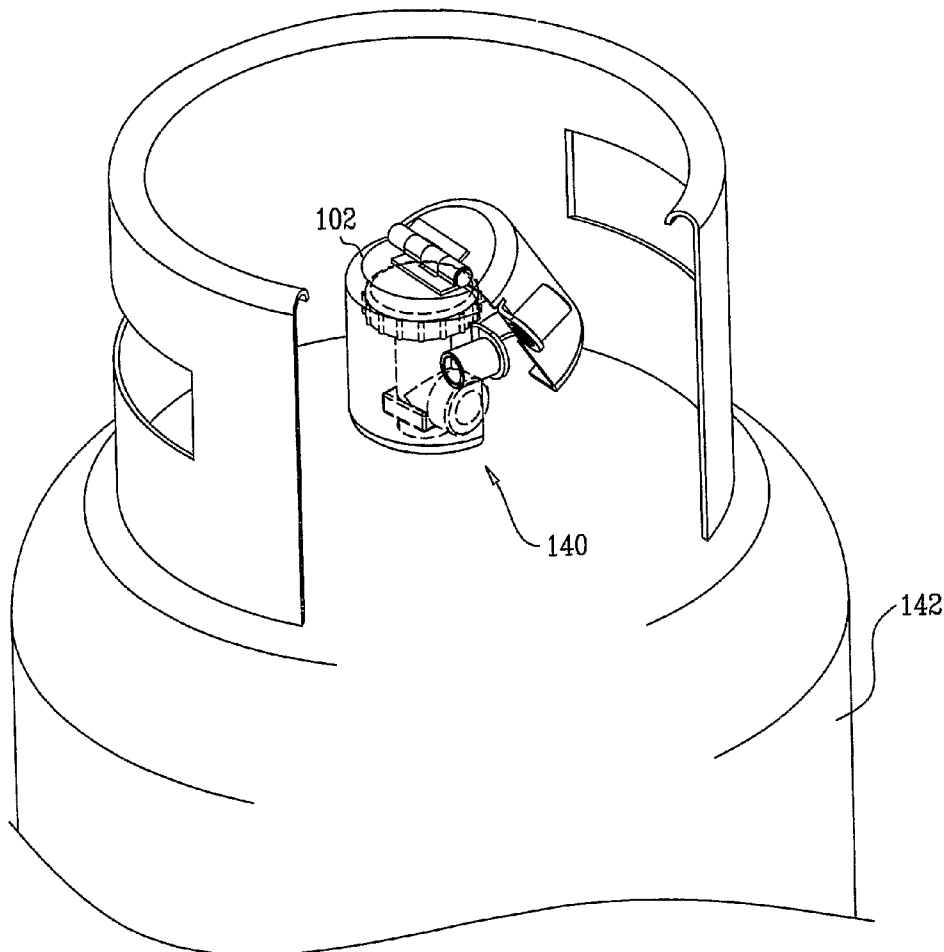

FIG. 1A

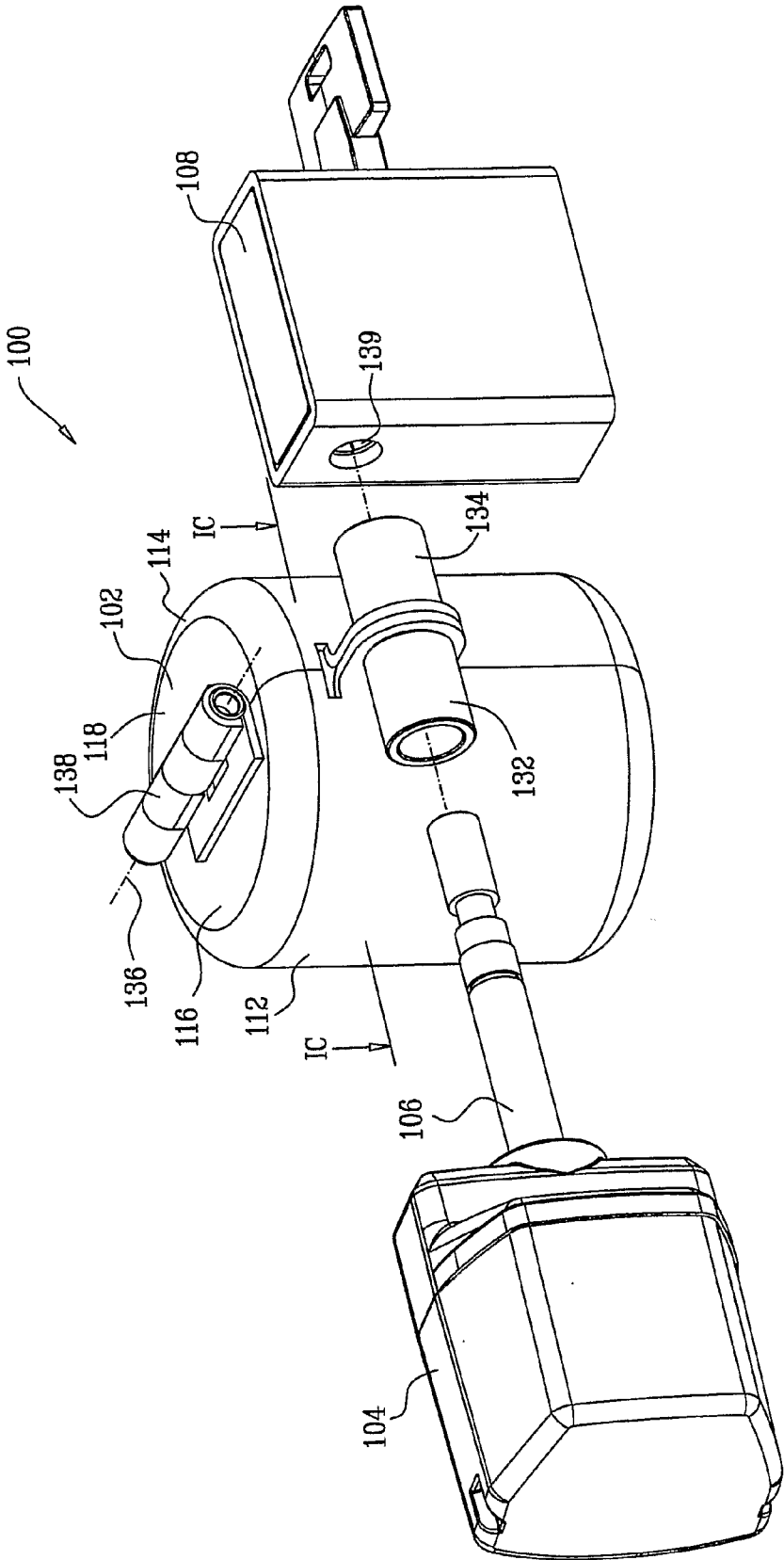

FIG. 1B

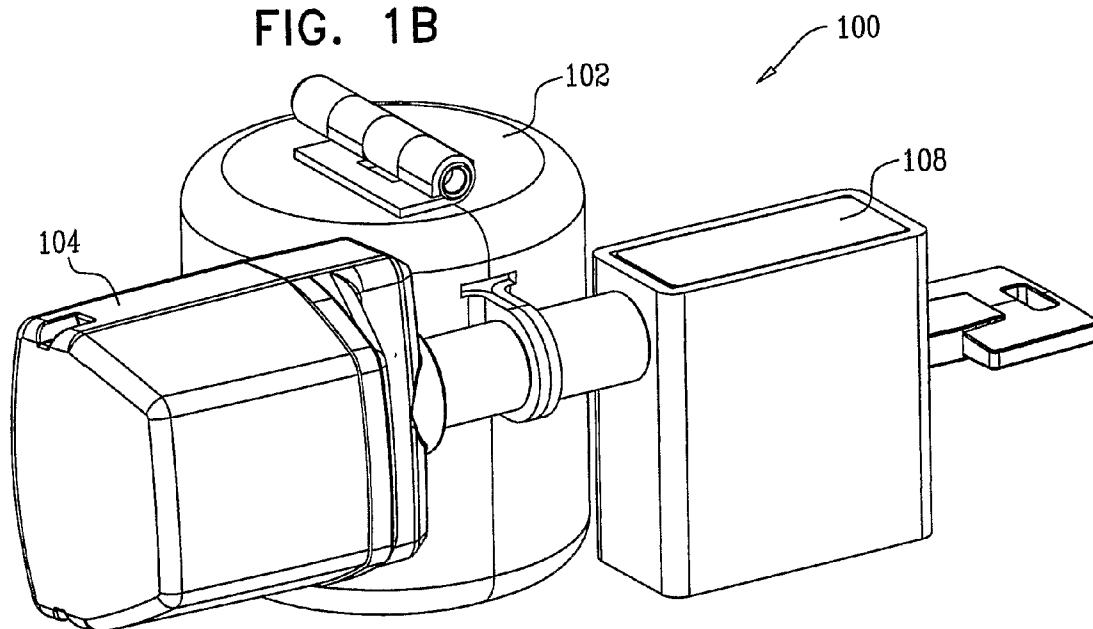

FIG. 1C

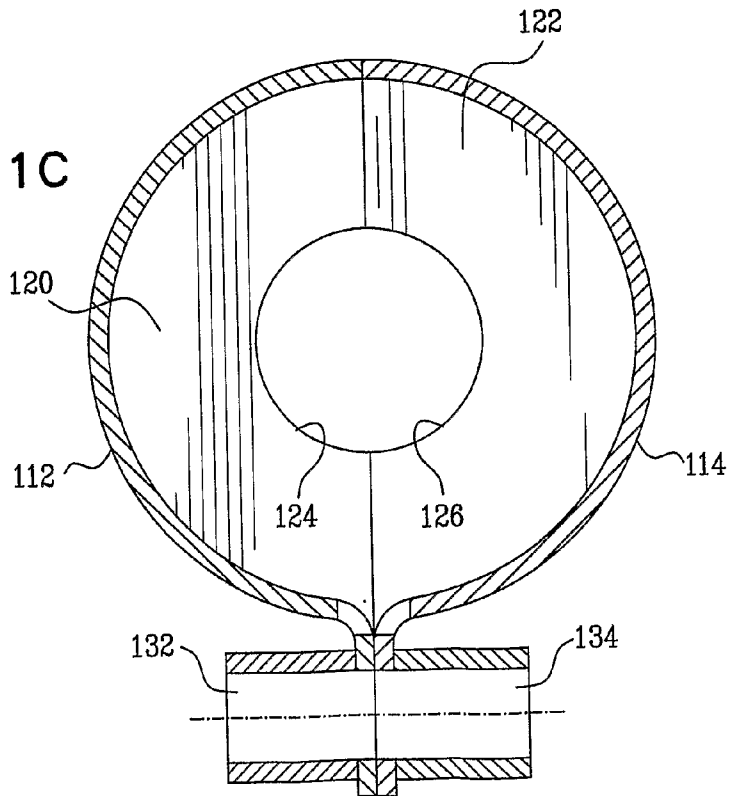
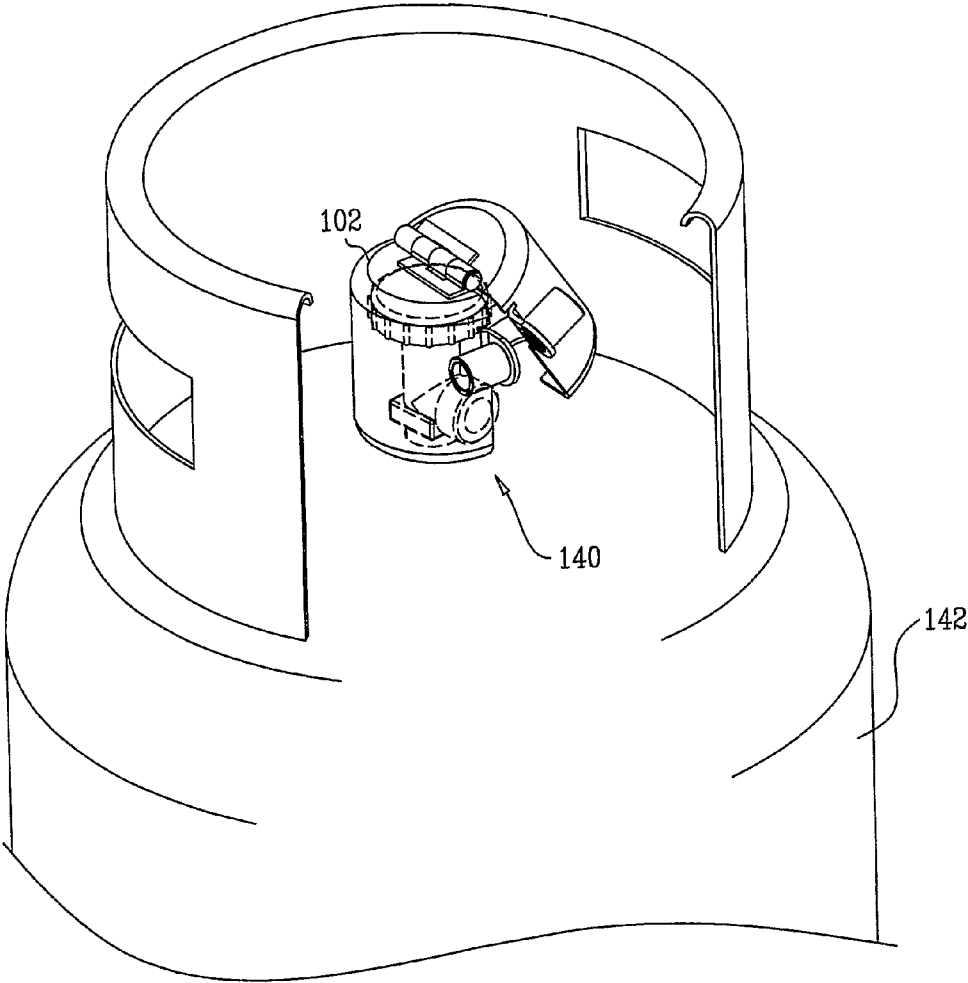
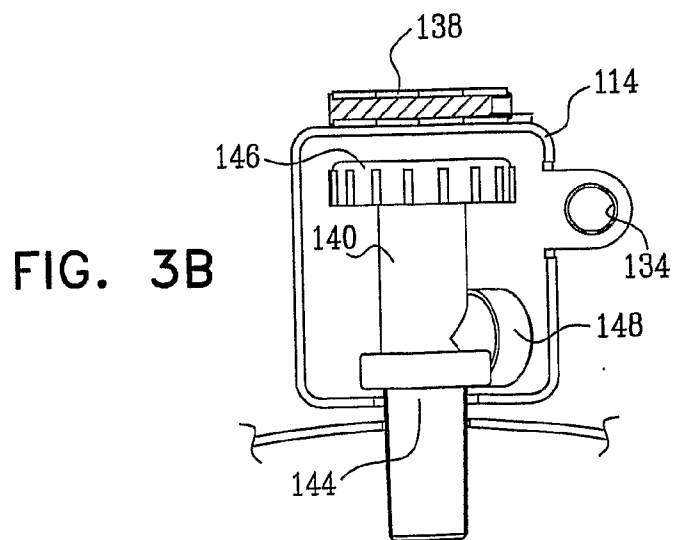
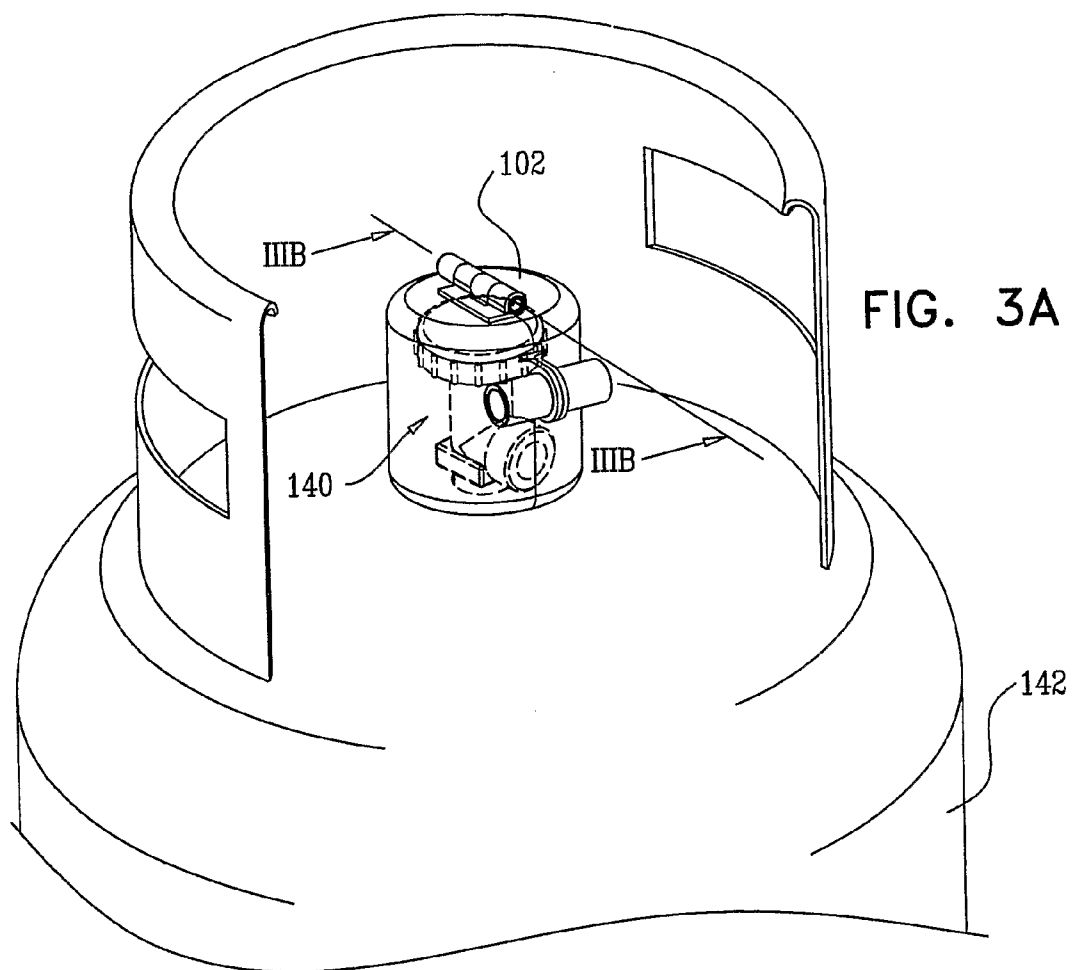

FIG. 2





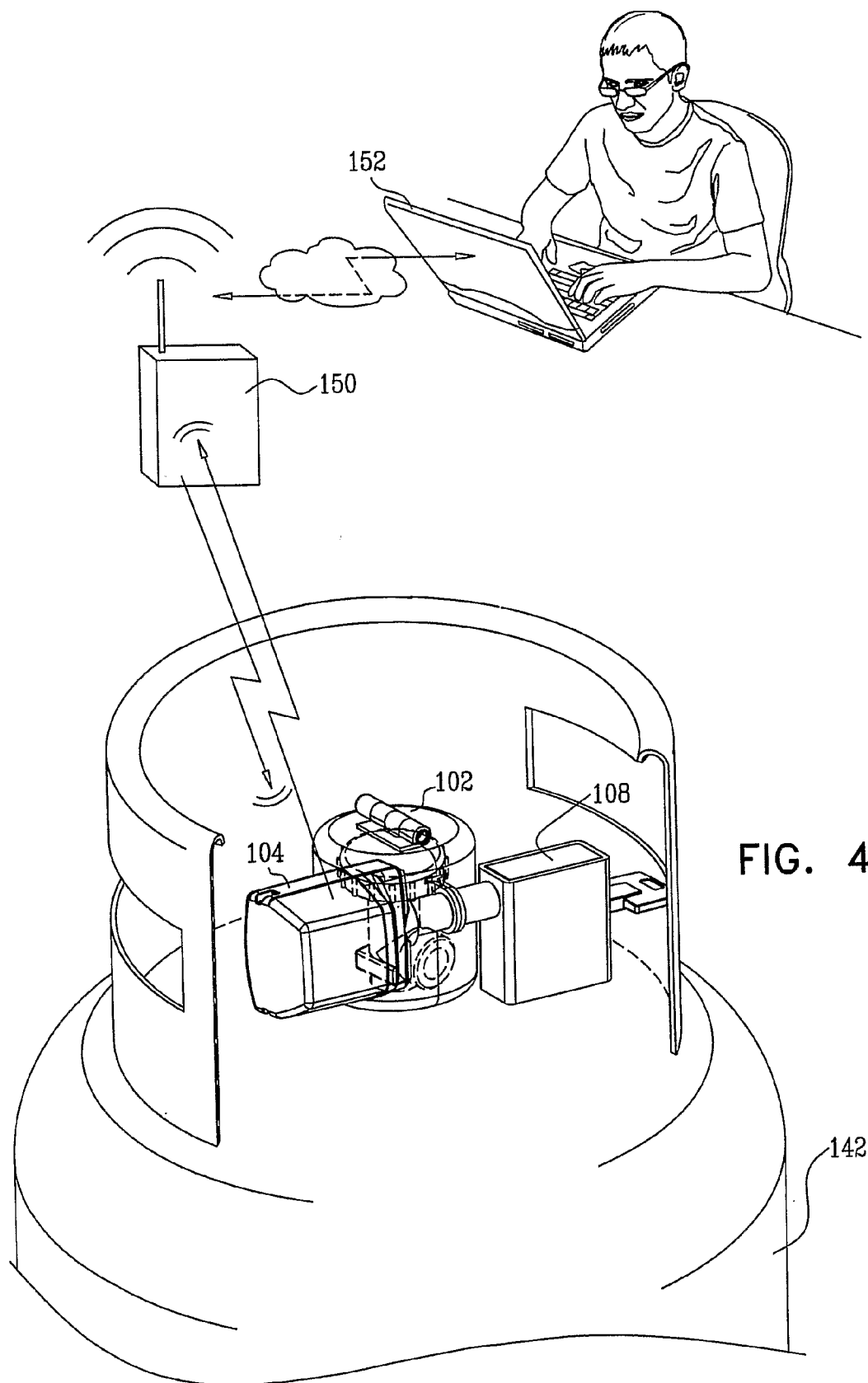

FIG. 4

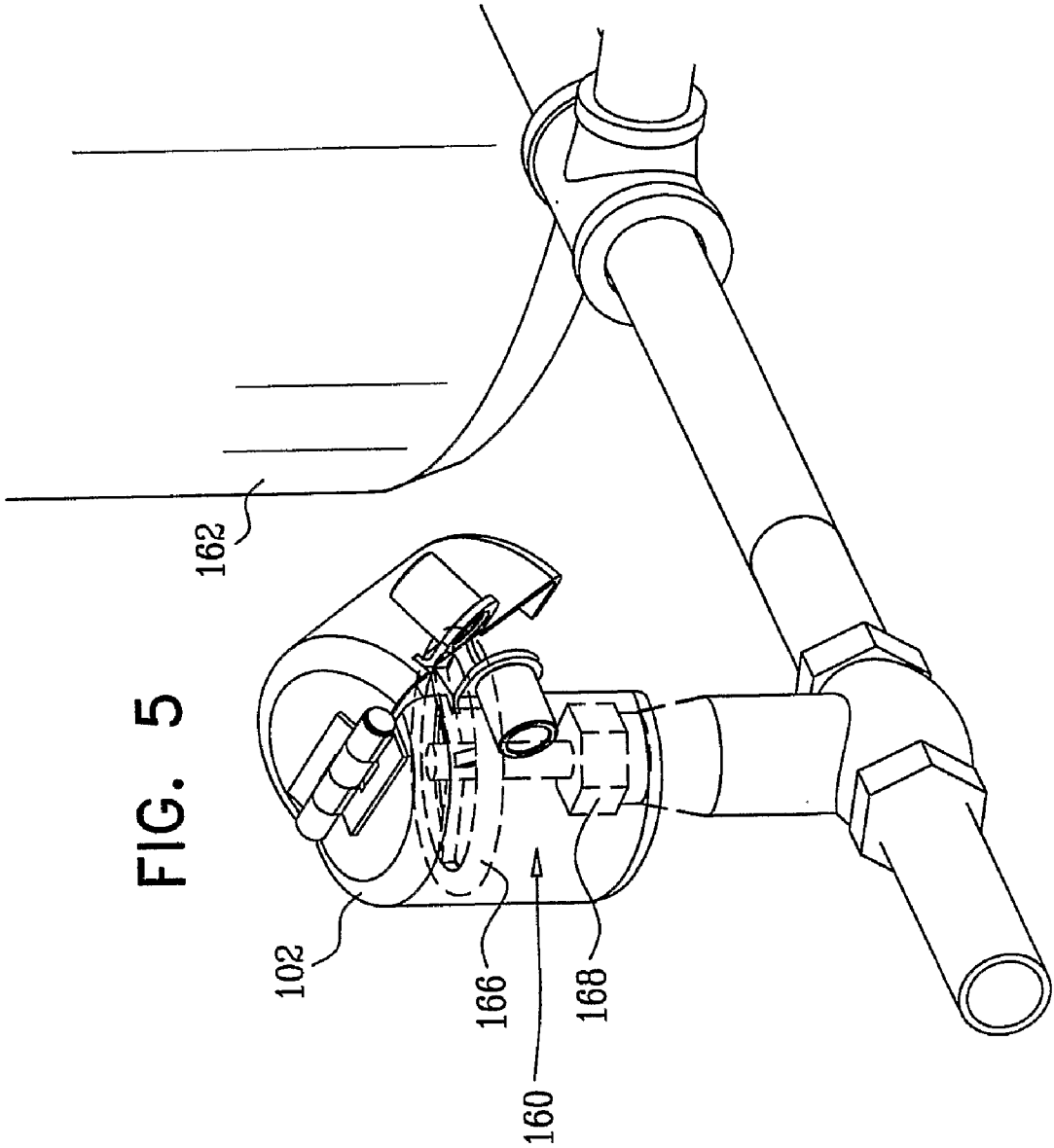

FIG. 6A

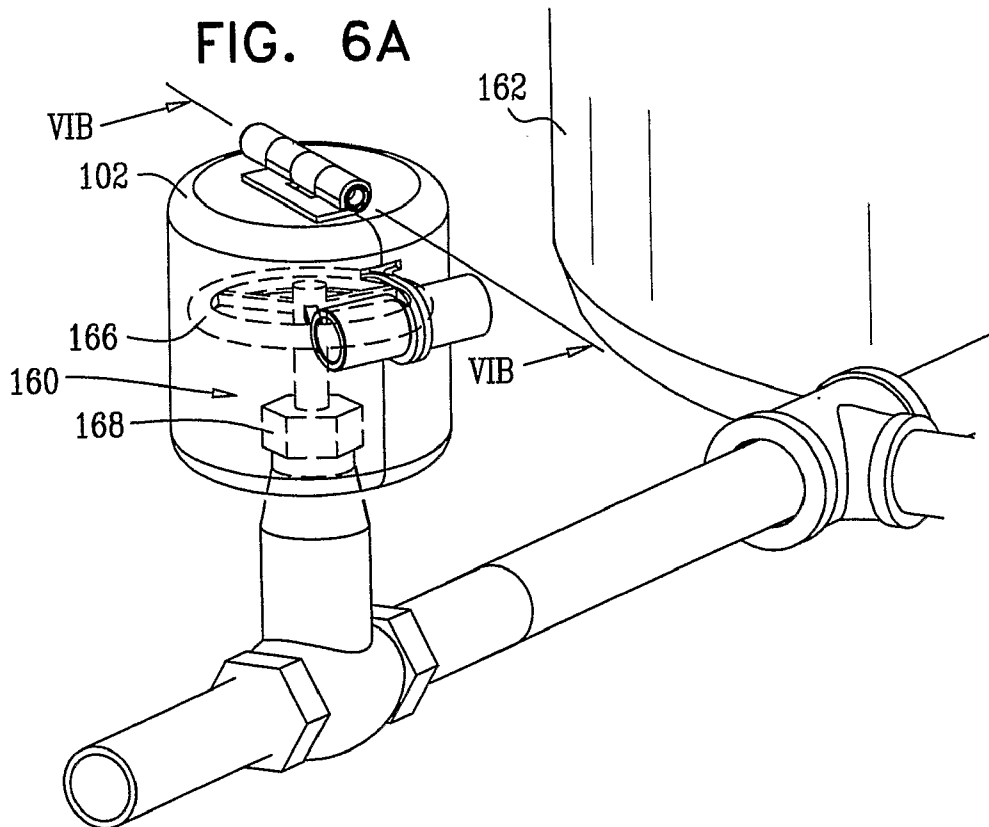
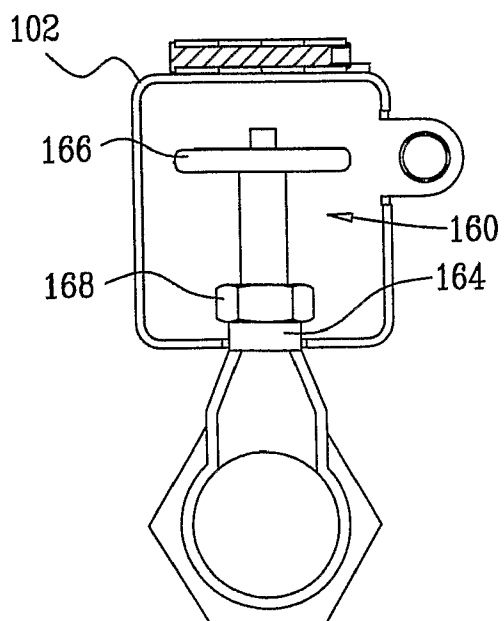
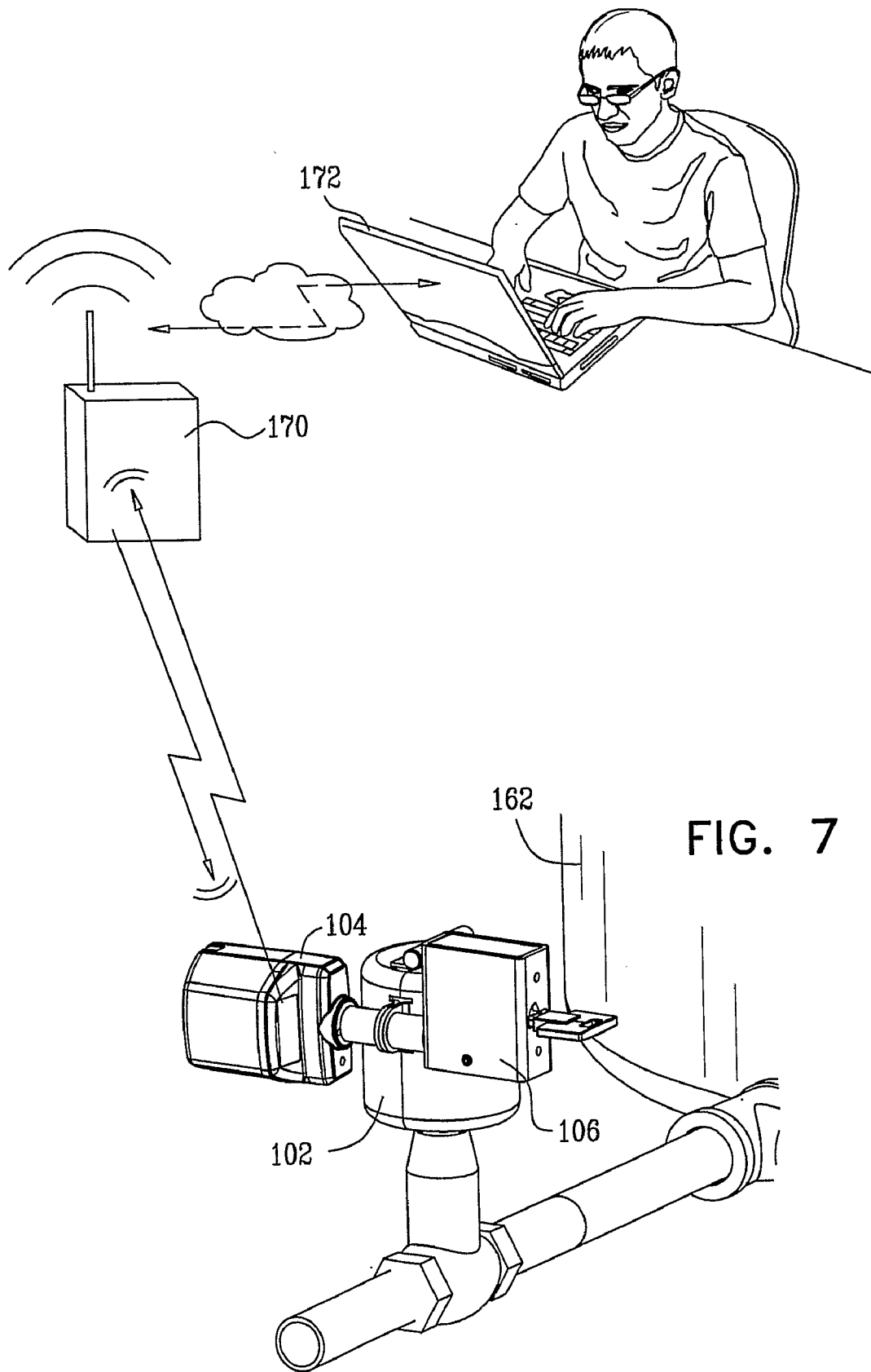

FIG. 6B





APPARATUS FOR LOCKING GAS CANISTERS

REFERENCE TO RELATED APPLICATIONS

[0001] Reference is hereby made to U.S. Provisional Patent Application Ser. No. 60/990,349, filed Nov. 27, 2007 and entitled APPARATUS FOR LOCKING GAS CANISTERS, the disclosure of which is hereby incorporated by reference and priority of which is hereby claimed under 37 CFR 1.78(a) (4) and (5)(i).

FIELD OF THE INVENTION

[0002] The present invention relates to locking devices generally and more particularly to remotely monitorable selectably removable locking devices.

BACKGROUND OF THE INVENTION

[0003] Various types of monitorable locking systems are known. Preferred locking systems of this type are commercially available from Hi-G-Tek Ltd. of Israel and are described in one or more of their issued U.S. Patents and published pending U.S. and PCT patent applications, the disclosures of which are hereby incorporated by reference.

SUMMARY OF THE INVENTION

[0004] The present invention seeks to provide monitored selectably removable locking of the valves of conventional bottled gas canisters.

[0005] There is thus provided in accordance with a preferred embodiment of the present invention a remotely monitorable selectably removable lock assembly for a fluid valve assembly of a bottled gas canister or other fluid valve assembly, the remotely monitorable, selectably removable, lock assembly including a lockable cover assembly configured for lockable engagement with a fluid valve assembly, a remote monitoring unit fixedly mounted to a locking shaft, arranged for lockable engagement with the lockable cover assembly when the lockable cover assembly is in a closed operative orientation, preventing unauthorized access to the fluid valve assembly and a locking unit which is operative for locking engagement with the locking shaft for retaining the cover assembly in the closed operative orientation, the remote monitoring unit having wireless communication functionality enabling it to communicate with a remote monitoring station for providing monitorable indications both of tampering and of authorized unlocking of the locking unit from the locking shaft.

[0006] Preferably, the lockable cover assembly includes first and second generally semi-cylindrical elements. In accordance with a preferred embodiment, the first and second generally semi-cylindrical elements are mutually pivotably mounted about an axis.

[0007] Additionally or alternatively, each of the first and second generally semi-cylindrical elements includes a closed top end wall surface and a bottom end wall surface. Additionally, the bottom end wall surface includes a semi-circular cut-out portion. Preferably, the semi-circular cut-out portions engage a neck portion of the valve assembly when the lockable cover assembly is in a closed operative orientation.

[0008] In accordance with a preferred embodiment of the present invention each of the first and second generally semi-cylindrical elements includes a generally cylindrical locking shaft receiving portion. Preferably, the generally cylindrical

locking shaft receiving portions are arranged to be coaxial when the lockable cover assembly is in a closed operative orientation. Additionally, the generally cylindrical locking shaft receiving portions are configured to slidably receive the locking shaft.

BRIEF DESCRIPTION OF THE DRAWINGS

[0009] The present invention will be understood and appreciated more fully from the following detailed description, taken in conjunction with the drawings in which:

[0010] FIG. 1A is a simplified pictorial illustration of a remotely monitorable selectably removable lock assembly for a valve of a bottled gas canister or other fluid faucet or valve, constructed and operative in accordance with a preferred embodiment of the present invention, shown in an unlocked operative orientation;

[0011] FIG. 1B is a simplified pictorial illustration of the lock assembly of FIG. 1A, shown in a locked operative orientation;

[0012] FIG. 1C is a sectional illustration of a protective cover assembly forming part of the lock assembly of FIGS. 1A and 1B, taken along lines 1C-1C of FIG. 1A;

[0013] FIG. 2 is a simplified pictorial illustration of the protective cover assembly of the lock assembly of FIGS. 1A-1C in an open operative orientation, following placement thereof over a valve of a gas canister;

[0014] FIG. 3A is a simplified pictorial illustration of the protective cover assembly of the lock assembly of FIGS. 1A-1C in a closed operative orientation, following placement thereof over a valve of a gas canister;

[0015] FIG. 3B is a simplified sectional illustration of the protective cover assembly of the lock assembly of FIG. 3A, taken along lines IIIB-IIIB of FIG. 3A;

[0016] FIG. 4 is a simplified pictorial illustration of the lock assembly of FIGS. 1A-1C in remotely monitorable locked engagement with the valve assembly of the gas canister;

[0017] FIG. 5 is a simplified pictorial illustration of the protective cover assembly of the lock assembly of FIGS. 1A-1C in an open operative orientation, following placement thereof over a valve assembly of a fluid container;

[0018] FIG. 6A is a simplified pictorial illustration of the protective cover assembly of the lock assembly of FIGS. 1A-1C in a closed operative orientation, following placement thereof over a valve of a fluid container;

[0019] FIG. 6B is a simplified sectional illustration of the protective cover assembly of the lock assembly of FIG. 6A, taken along lines VIB-VIB of FIG. 6A; and

[0020] FIG. 7 is a simplified pictorial illustration of the lock assembly of FIGS. 1A-1C in remotely monitorable locked engagement with the valve assembly of the fluid container.

DETAILED DESCRIPTION OF A PREFERRED EMBODIMENT

[0021] Reference is now made to FIGS. 1A and 1B, which are simplified pictorial illustrations of a remotely monitorable selectably removable lock assembly 100 for a valve assembly of a bottled gas canister or other fluid valve, shown in an unlocked operative orientation and locked operative orientation, respectively, constructed and operative in accordance with a preferred embodiment of the present invention, and to FIG. 1C, which is a sectional illustration a selectably-openable hinged protective cover assembly 102 forming part of the lock assembly 100 of FIGS. 1A and 1B.

[0022] As seen in FIGS. 1A-1C, the remotely monitorable selectably removable lock assembly 100 includes selectably-openable hinged protective cover assembly 102, a remote monitoring unit 104 fixedly mounted to a locking shaft 106, which is arranged for locking engagement with cover assembly 102 in a closed operative orientation, and a key-operable locking unit 108 which is operative for locking engagement with locking shaft 106 for retaining the cover assembly 102 in the closed operative orientation, as seen in FIG. 1B.

[0023] Selectably-openable hinged protective cover assembly 102 preferably comprises first and second generally semi-cylindrical elements 112 and 114 which have closed top end wall surfaces 116 and 118 and bottom end wall surfaces 120 and 122. As seen in FIG. 1C, bottom end wall surfaces 120 and 122 include respective semi-circular cut-out portions 124 and 126 for placement of hinged protective cover assembly 102 over a valve assembly of a gas canister or a fluid container, as described further hereinbelow with reference to FIGS. 3A-3B and 6A-6B.

[0024] Elements 112 and 114 are provided with a respective generally cylindrical locking shaft receiving portions 132 and 134, which are arranged to be coaxial when the cover assembly 102 is in its closed operative orientation as shown in FIGS. 1A-1C. Elements 112 and 114 are preferably mutually pivotably mounted about an axis 136 by a hinge 138 fixed to top end wall surfaces 116 and 118.

[0025] The remote monitoring unit 104 and the locking shaft 106, which is fixedly mounted thereto, are commercially available from Hi-G-Tek Ltd. of Israel, and are designated preferably by one of the following model designations: IG-LK-40-433 and IG-LK-40-916. Locking shaft receiving portions 132 and 134 are configured to slidably receive locking shaft 106.

[0026] Key-operable locking unit 108 may be any suitable key-operated lock and is preferably a conventional pin lock, which is commercially available from Mul-T-Lock Ltd. of Yavne, Israel.

[0027] Locking shaft 106 is configured to extend through locking shaft receiving portions 132 and 134 and through an aperture 139 in key-operable locking unit 108 into lockable engagement with key-operable locking unit 108. Remote monitoring unit 104 is operative such that unlocking of key-operable locking unit 108 from locking shaft 106 or unauthorized disengagement of cover assembly 102, such as in an unauthorized attempt to remove cover assembly 102 from the locking system or otherwise tamper with the locking system, will be monitored and wirelessly notified to a monitoring center (not shown).

[0028] Reference is now made to FIG. 2, which is a simplified pictorial illustration of protective cover assembly 102 of lock assembly 100 of FIGS. 1A-1C in an open operative orientation, following placement thereof over a valve of a gas canister, and to FIGS. 3A and 3B, which are, respectively, a simplified pictorial illustration and a sectional illustration of protective cover assembly 102 of lock assembly 100 of FIGS. 1A-1C in a closed operative orientation, following placement thereof over a valve of a gas canister.

[0029] The initial engagement of cover assembly 102 with a valve assembly 140 of a gas canister 142 is seen in FIG. 2. FIGS. 3A and 3B show cover assembly 102 in a closed operative orientation such that semi-circular cut-out portions 124 and 126 of bottom end wall surfaces 120 and 122 engage

a neck portion 144 of valve assembly 140 and prevent unauthorized lifting and removal of cover assembly 102 from valve assembly 140.

[0030] Preferably, when in a closed orientation as seen in FIGS. 3A & 3B, cover assembly 102 is operative to cover a flow control knob 146 and a threaded connection portion 148 of the valve assembly 140 and thus to prevent unauthorized access thereto and removal thereof and to monitor authorized access thereto.

[0031] Reference is now made to FIG. 4, which shows lock assembly 100 of FIGS. 1A-1C in remotely monitorable locked engagement with valve assembly 140 of gas canister 142. Locking shaft 106 extends through coaxial locking shaft receiving portions 132 and 134, fixed to elements 112 and 114 of cover assembly 102, which are in a closed operative location. Locking unit 108 prevents disengagement of locking shaft 106 from receiving portions 132 and 134 and thus prevents opening of cover assembly 102 and disengagement thereof from the valve assembly 140.

[0032] Remote monitoring unit 104 communicates, preferably via a wireless communication link, such as by RF communication or any other suitable communication, with a remote communication device 150, for providing monitorable indications both of tampering and of authorized unlocking of locking unit 108 from locking shaft 106. Remote communication device 150 is preferably operative to communicate with a computer 152 or other remotely located device, typically via a network, such as the Internet.

[0033] Reference is now made to FIG. 5, which is a simplified pictorial illustration of protective cover assembly 102 of lock assembly 100 of FIGS. 1A-1C in an open operative orientation, following placement thereof over a valve assembly of a fluid container, and to FIGS. 6A and 6B, which are, respectively, a simplified pictorial illustration and a sectional illustration of lock assembly 100 of FIGS. 1A-1C in remotely monitorable locked engagement with the valve assembly of the fluid container.

[0034] FIG. 5 shows the initial engagement of cover assembly 102 with a valve assembly 160 of a fluid container 162. FIGS. 6A and 6B show the cover assembly 102 in a closed and locked operative orientation such that semi-circular cut-out portions 124 and 126 of bottom end wall surfaces 120 and 122 engage a neck portion 164 of valve assembly 160 and prevent unauthorized lifting and removal of cover assembly 102 from valve assembly 160.

[0035] Preferably, when in a closed orientation as seen in FIGS. 6A & 6B, cover assembly 102 is operative to cover a flow control knob 166 and a threaded connection portion 168 of the valve assembly 160 and thus to prevent unauthorized access thereto and removal thereof and to monitor authorized access thereto.

[0036] As seen in FIG. 6B, protective cover assembly 102 is operative to cover the entire valve assembly 160 of fluid container 162, to prevent unauthorized removal thereof.

[0037] Reference is now made to FIG. 7, which shows lock assembly of FIGS. 1A-1C in remotely monitorable locked engagement with the valve assembly 160 of the fluid container 162. Locking shaft 106 extends through coaxial locking shaft receiving portions 132 and 134, fixed to elements 112 and 114 of cover assembly 102, which are in a closed operative location. Locking unit 108 prevents disengagement of locking shaft 106 from receiving portions 132 and 134 and thus prevents opening of cover assembly 102 and disengagement thereof from the valve assembly 160.

[0038] Remote monitoring unit **104** communicates, preferably via a wireless communication link, such as by RF communication or any other suitable communication, with a remote communication device **170**, for providing monitorable indications both of tampering and of authorized unlocking of locking unit **108** from locking shaft **106**. Remote communication device **170** is preferably operative to communicate with a computer **172** or other remotely located, device, typically via a network, such as the Internet.

[0039] It will be appreciated by persons skilled in the art that the present invention is not limited by what has been particularly shown and described hereinabove. Rather the scope of the present invention includes both combinations and sub-combinations of various feature of the invention and modifications thereof which may occur to persons skilled in the art upon reading the foregoing description and which are not in the prior art.

1. A remotely monitorable selectably removable lock assembly for a fluid valve assembly of a bottled gas canister or other fluid valve assembly, the remotely monitorable, selectably removable, lock assembly comprising:

a lockable cover assembly configured for lockable engagement with a fluid valve assembly;

a remote monitoring unit fixedly mounted to a locking shaft, arranged for lockable engagement with said lockable cover assembly when said lockable cover assembly is in a closed operative orientation, preventing unauthorized access to said fluid valve assembly; and

a locking unit which is operative for locking engagement with said locking shaft for retaining said cover assembly in said closed operative orientation,

said remote monitoring unit having wireless communication functionality enabling it to communicate with a remote monitoring station for providing monitorable indications both of tampering and of authorized unlocking of said locking unit from said locking shaft.

2. A remotely monitorable selectably removable lock assembly according to claim **1** and wherein said lockable cover assembly comprises first and second generally semi-cylindrical elements.

3. A remotely monitorable selectably removable lock assembly according to claim **2** and wherein said first and second generally semi-cylindrical elements are mutually pivotably mounted about an axis.

4. A remotely monitorable selectably removable lock assembly according to claim **2** and wherein each of said first and second generally semi-cylindrical elements includes a closed top end wall surface and a bottom end wall surface.

5. A remotely monitorable selectably removable lock assembly according to claim **4** and wherein said bottom end wall surface includes a semi-circular cut-out portion.

6. A remotely monitorable selectably removable lock assembly according to claim **5** and wherein said semi-circular cut-out portions engage a neck portion of said valve assembly when said lockable cover assembly is in a closed operative orientation.

7. A remotely monitorable selectably removable lock assembly according to claim **2** and wherein each of said first and second generally semi-cylindrical elements includes a generally cylindrical locking shaft receiving portion.

8. A remotely monitorable selectably removable lock assembly according to claim **7** and wherein said generally cylindrical locking shaft receiving portions are arranged to be coaxial when said lockable cover assembly is in a closed operative orientation.

9. A remotely monitorable selectably removable lock assembly according to claim **7** and wherein said generally cylindrical locking shaft receiving portions are configured to slidably receive said locking shaft.

* * * * *