



US008783458B2

(12) **United States Patent**
Gallagher et al.

(10) **Patent No.:** **US 8,783,458 B2**

(45) **Date of Patent:** ***Jul. 22, 2014**

(54) **PORTABLE ELECTRONIC DEVICE CASE ACCESSORIES AND RELATED SYSTEMS AND METHODS**

(71) Applicant: **Targus Group International, Inc.**, Anaheim, CA (US)

(72) Inventors: **Kevin Gallagher**, Los Angeles, CA (US); **Robert Shortt**, Laguna Beach, CA (US); **Daniel Ballou**, Long Beach, CA (US); **Ronald DeCamp**, Westminster, CA (US); **Mark Thoni**, Rancho Santa Margarita, CA (US); **James C. Frinak**, Los Angeles, CA (US)

(73) Assignee: **Targus Group International, Inc.**, Anaheim, CA (US)

(*) Notice: Subject to any disclaimer, the term of this patent is extended or adjusted under 35 U.S.C. 154(b) by 0 days.

This patent is subject to a terminal disclaimer.

(21) Appl. No.: **14/099,436**

(22) Filed: **Dec. 6, 2013**

(65) **Prior Publication Data**

US 2014/0098478 A1 Apr. 10, 2014

Related U.S. Application Data

(63) Continuation of application No. 13/791,445, filed on Mar. 8, 2013, which is a continuation of application No. 13/155,266, filed on Jun. 7, 2011.

(60) Provisional application No. 61/352,286, filed on Jun. 7, 2010, provisional application No. 61/368,048, filed on Jul. 27, 2010, provisional application No. 61/421,431, filed on Dec. 9, 2010.

(51) **Int. Cl.**

- B65D 85/00** (2006.01)
- F16M 13/04** (2006.01)
- F16M 11/10** (2006.01)
- F16M 11/20** (2006.01)
- G06F 1/16** (2006.01)
- F16M 13/00** (2006.01)
- H05K 5/02** (2006.01)

(52) **U.S. Cl.**

CPC **G06F 1/1633** (2013.01); **F16M 13/04** (2013.01); **F16M 11/105** (2013.01); **F16M 11/2078** (2013.01); **F16M 11/2021** (2013.01); **F16M 13/005** (2013.01); **H05K 5/0226** (2013.01)

USPC **206/320**; 206/45.2

(58) **Field of Classification Search**

USPC 206/320, 45.25, 45.2, 45.21, 45.26, 206/760, 767, 768, 754, 755, 766, 765, 762, 206/757, 759, 772, 774

See application file for complete search history.

(56) **References Cited**

U.S. PATENT DOCUMENTS

1,121,422 A 12/1914 Tydings
2,554,215 A 5/1951 Schell et al.

(Continued)

FOREIGN PATENT DOCUMENTS

EP 1 548 544 A2 6/2005
EP 2 392 986 A2 12/2011

(Continued)

OTHER PUBLICATIONS

Non-Final Office Action for U.S. Appl. No. 13/791,445, filed Mar. 8, 2013, and mailed from the USPTO on Dec. 27, 2013, 8 pgs.

(Continued)

Primary Examiner — Jacob K Ackun

Assistant Examiner — Jenine Pagan

(74) *Attorney, Agent, or Firm* — John R. Thompson; Stoel Rives LLP

(57) **ABSTRACT**

Case accessories for portable electronic devices are disclosed. In some embodiments, a case accessory may include a base configured to sit on a working surface, a support coupled to the base and configured to support a portable electronic device in an elevated position, a rotational mechanism coupled to the support configured to allow the holder to rotate in one or more directions relative to the support, and a holder coupled to the rotational mechanism and configured to secure the portable electronic device.

20 Claims, 54 Drawing Sheets

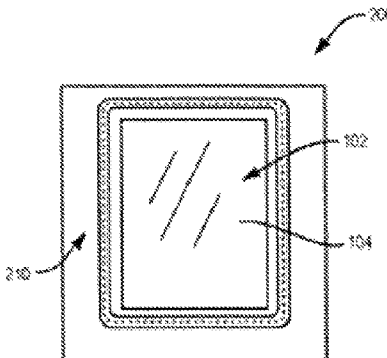
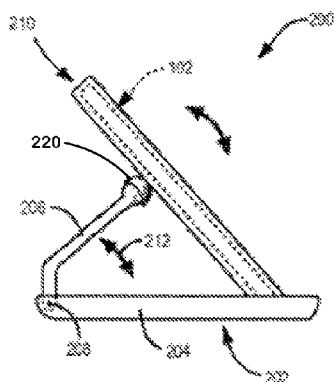

(56)

References Cited

U.S. PATENT DOCUMENTS

2,556,066 A 6/1951 Cline
 3,292,778 A 12/1966 Enderle
 3,441,072 A 4/1969 Schmitt
 3,530,213 A 9/1970 Isle
 3,620,149 A 11/1971 Ogihara
 4,106,597 A 8/1978 Shook et al.
 4,259,568 A 3/1981 Dynesen
 4,700,832 A 10/1987 Champ
 4,901,897 A 2/1990 Briggs et al.
 5,024,328 A 6/1991 Bontrager
 5,165,649 A 11/1992 Neumann et al.
 5,207,327 A 5/1993 Brondos
 5,217,119 A 6/1993 Hollingsworth
 5,330,049 A 7/1994 Bertelsen et al.
 5,356,004 A 10/1994 Weinreb
 5,524,754 A 6/1996 Hollingsworth
 5,544,792 A 8/1996 Arnwine
 5,555,157 A 9/1996 Moller et al.
 5,594,619 A 1/1997 Miyagawa et al.
 5,607,054 A 3/1997 Hollingsworth
 5,622,262 A 4/1997 Sadow
 5,769,221 A 6/1998 Cyr
 5,775,496 A 7/1998 Cyr
 5,797,044 A 8/1998 Lawther et al.
 5,887,723 A 3/1999 Myles
 5,971,148 A 10/1999 Jackson
 6,082,543 A 7/2000 Béliveau
 6,131,734 A 10/2000 Hollingsworth et al.
 6,173,933 B1 1/2001 Whiteside et al.
 6,237,766 B1 5/2001 Hollingsworth
 6,334,533 B1 1/2002 Hollingsworth et al.
 6,334,534 B1 1/2002 Hollingsworth et al.
 6,535,199 B1 3/2003 Canova, Jr. et al.
 D476,149 S 6/2003 Andre et al.
 6,746,638 B1 6/2004 Zadesky et al.
 6,772,879 B1 8/2004 Domotor
 6,785,566 B1 8/2004 Irizarry
 D500,923 S 1/2005 Gonzalez et al.
 D527,176 S 8/2006 Andre et al.
 D529,717 S 10/2006 Brancky
 D533,348 S 12/2006 Andre et al.
 7,207,154 B2 4/2007 Araujo
 D541,646 S 5/2007 Hayes et al.
 7,281,698 B2 10/2007 Patterson, Jr.
 D574,375 S 8/2008 Prest et al.
 D574,819 S 8/2008 Andre et al.
 7,414,833 B2 8/2008 Kittayapong
 7,451,872 B1 11/2008 Allen
 D582,405 S 12/2008 Andre et al.
 7,467,695 B2 12/2008 Gormick et al.
 7,495,895 B2 2/2009 Carnevali
 7,500,561 B2 3/2009 Matias et al.
 7,503,440 B2 3/2009 Gormick et al.
 7,735,644 B2 6/2010 Sirichai et al.
 7,747,007 B2 6/2010 Hyun et al.
 D623,404 S 9/2010 Andre et al.
 D623,638 S 9/2010 Richardson et al.
 D623,639 S 9/2010 Richardson et al.
 7,876,550 B1 1/2011 Albertini et al.
 8,016,107 B2 9/2011 Emsky
 8,051,980 B2 11/2011 Tai et al.
 8,132,670 B1 3/2012 Chen
 D658,363 S 5/2012 Biddle
 8,173,893 B2 5/2012 Huang
 8,201,687 B2 6/2012 Zeliff et al.
 8,230,992 B2 7/2012 Law et al.
 8,235,208 B2 8/2012 Sirichai et al.
 8,281,950 B2 10/2012 Potts et al.
 8,312,991 B2 11/2012 Diebel et al.
 8,328,008 B2 12/2012 Diebel et al.
 8,467,183 B2 6/2013 Probst et al.
 8,573,394 B2 11/2013 Ahee et al.
 2001/0014010 A1 8/2001 Jenks et al.
 2001/0052710 A1 12/2001 Witherell
 2002/0179470 A1* 12/2002 Lee 206/320

2003/0186729 A1 10/2003 Engstrom et al.
 2004/0018863 A1 1/2004 Engstrom et al.
 2004/0224732 A1* 11/2004 Lee et al. 455/575.3
 2004/0240164 A1 12/2004 Lee
 2005/0057893 A1 3/2005 Homer et al.
 2005/0237701 A1 10/2005 Yu
 2007/0001079 A1 1/2007 Patterson, Jr.
 2007/0056865 A1 3/2007 Pelo
 2007/0057140 A1 3/2007 Liou et al.
 2007/0166028 A1 7/2007 Kranz et al.
 2007/0279855 A1 12/2007 Linsmeier et al.
 2008/0043411 A1 2/2008 Chih et al.
 2008/0045279 A1* 2/2008 Ohki 455/575.1
 2008/0055835 A1 3/2008 Kumano et al.
 2008/0226286 A1 9/2008 Huang
 2008/0237432 A1 10/2008 Patterson
 2008/0302687 A1 12/2008 Sirichai et al.
 2009/0109558 A1 4/2009 Schaefer
 2009/0127423 A1 5/2009 Chen et al.
 2009/0178938 A1 7/2009 Palmer
 2009/0223765 A1 9/2009 Bosma
 2009/0223845 A1 9/2009 Bosma et al.
 2009/0230006 A1 9/2009 Pidgley et al.
 2010/0072334 A1 3/2010 Le Gette et al.
 2010/0082445 A1 4/2010 Hodge et al.
 2010/0116710 A1 5/2010 Huang et al.
 2010/0225429 A1 9/2010 Tsai
 2010/0258602 A1 10/2010 Amin
 2011/0034221 A1 2/2011 Hung et al.
 2011/0090626 A1 4/2011 Hoellwarth et al.
 2011/0221319 A1 9/2011 Law et al.
 2011/0284420 A1 11/2011 Sajid
 2011/0290687 A1 12/2011 Han
 2011/0297566 A1 12/2011 Gallagher et al.
 2011/0315579 A1 12/2011 Mase
 2012/0012483 A1 1/2012 Fan
 2012/0217174 A1 8/2012 Ting
 2013/0126365 A1 5/2013 Hung

FOREIGN PATENT DOCUMENTS

EP 2 337 373 B1 12/2013
 JP H073344 U 1/1995
 JP 09135722 A 5/1997
 JP 2000014426 A 1/2000
 JP 2004509680 A 4/2004
 WO WO 01/90848 A2 11/2001
 WO WO 2010/036090 A2 4/2010
 WO WO 2011/115918 A1 9/2011
 WO WO 2011/130157 A2 10/2011

OTHER PUBLICATIONS

Office Action for U.S. Appl. No. 13/739,846, filed Jan. 11, 2013, mailed Feb. 27, 2014, 19 pgs.
 International Searching Authority, International Search Report and Written Opinion of PCT/2011/039287, filed Jun. 6, 2011, and mailed Dec. 28, 2011, 11 pgs.
 International Preliminary Report on Patentability for PCT/2011/039287 filed Jun. 6, 2011, and mailed Dec. 20, 2012, 7 pgs.
 Office Action for U.S. Appl. No. 12/370,824, filed Feb. 13, 2009, and mailed from the USPTO on Jan. 4, 2013, (19 pgs.).
 Office Action for U.S. Appl. No. 13/171,225, filed Jun. 28, 2011, and mailed from the USPTO on Apr. 16, 2013, 24 pgs.
 Office Action for U.S. Appl. No. 13/285,565, filed Oct. 31, 2011, and mailed from the USPTO on May 9, 2013, 14 pgs.
 Office Action for U.S. Appl. No. 12/370,824, filed Feb. 13, 2009, and mailed from the USPTO on May 20, 2013, 22 pgs.
 Office Action for U.S. Appl. No. 13/791,445, filed Mar. 8, 2013, and mailed from the USPTO on Jun. 21, 2013, 20 pgs.
 Third-Party Submission for U.S. Appl. No. 13/791,445, filed Mar. 8, 2013, filed by Raymond Meiers on Jul. 31, 2013, and mailed from USPTO Aug. 5, 2013, 14 pgs. + 2 pgs. from USPTO.
 Notice of Allowance and Fee(s) Due for U.S. Appl. No. 12/370,824, filed Feb. 13, 2009, and mailed from the USPTO on Sep. 9, 2013, 12 pgs.

(56)

References Cited

OTHER PUBLICATIONS

Office Action for U.S. Appl. No. 13/747,992, filed Jan. 23, 2013, and mailed from the USPTO on Oct. 23, 2013, 21 pgs.

Office Action for U.S. Appl. No. 13/791,445, filed Mar. 8, 2013, and mailed from the USPTO on Oct. 23, 2013, 21 pgs.

Office Action for U.S. Appl. No. 13/171,225, filed Jun. 28, 2011, and mailed from the USPTO on Dec. 4, 2013, 17 pgs.

Notice of Allowance and Fee(s) Due for U.S. Appl. No. 29/431,992, filed Sep. 12, 2012, and mailed from the USPTO on Apr. 2, 2014, 27 pgs.

* cited by examiner

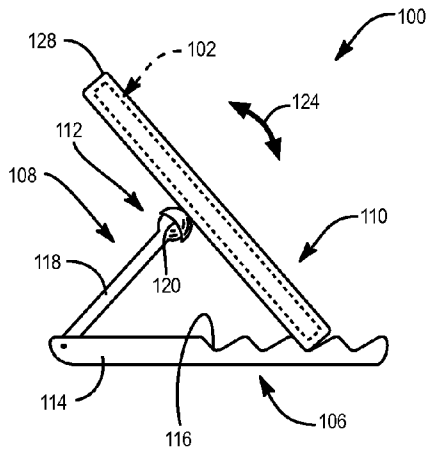

FIG. 1

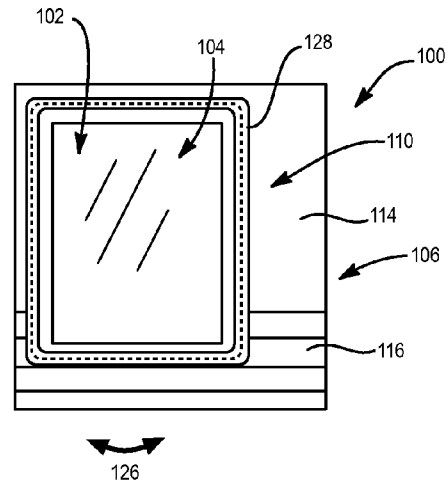

FIG. 2

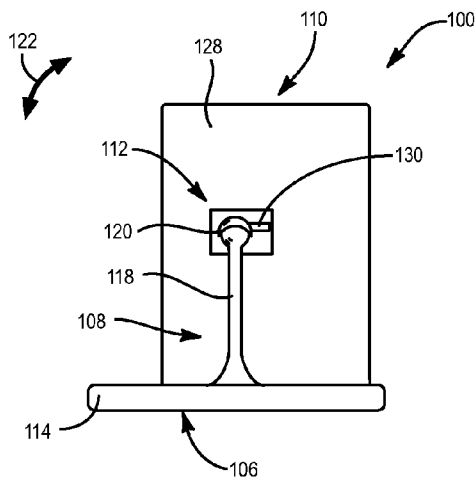

FIG. 3

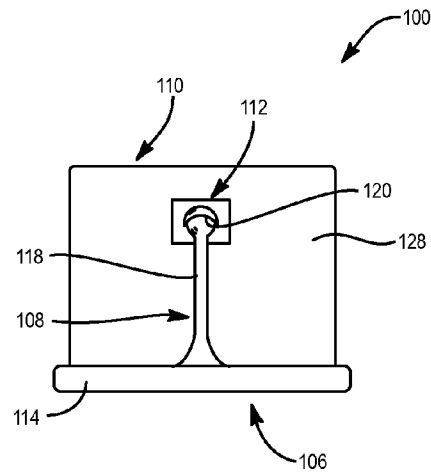

FIG. 4

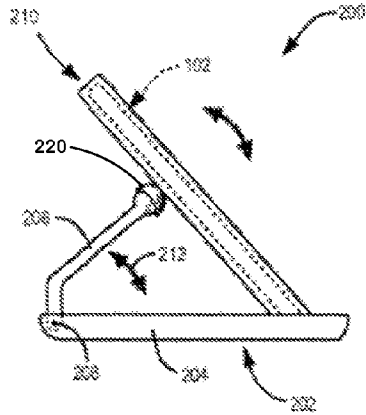

FIG. 5

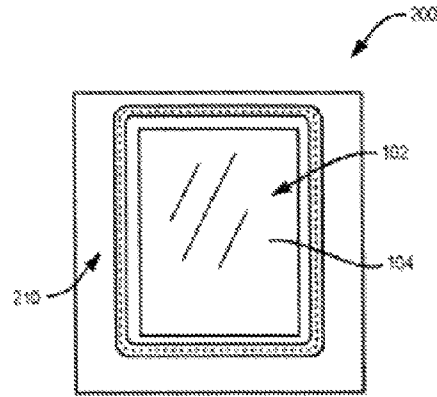

FIG. 6

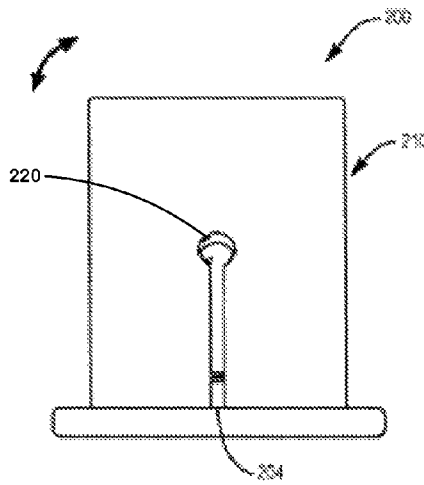

FIG. 7

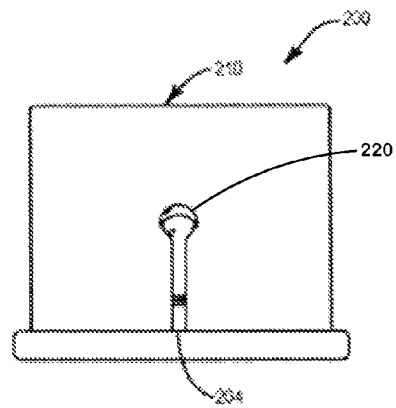

FIG. 8

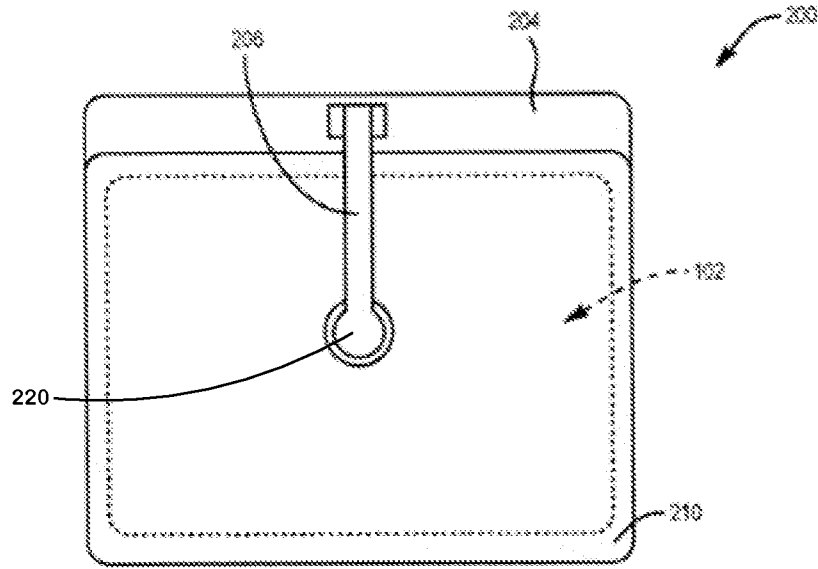

FIG. 9

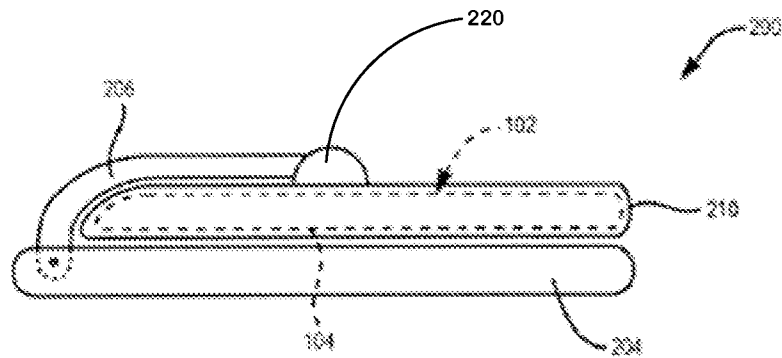

FIG. 10

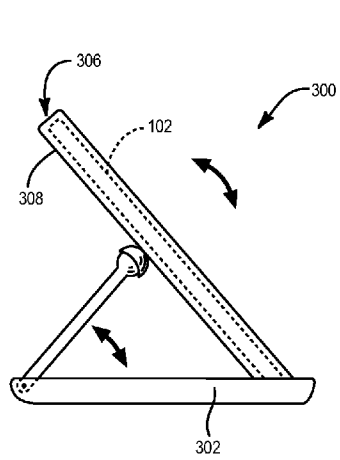

FIG. 11

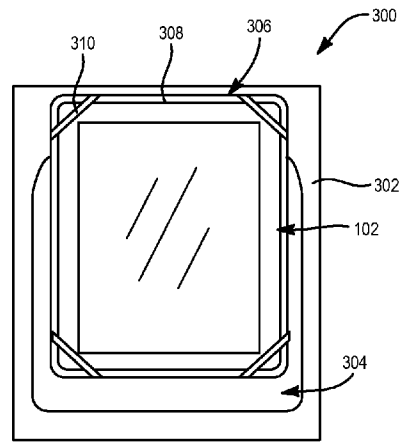

FIG. 12

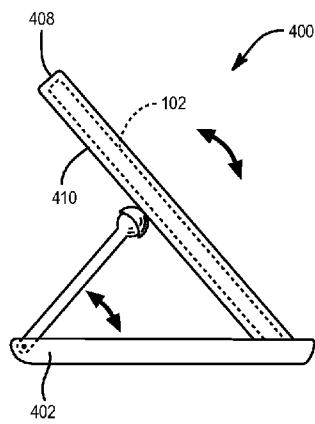

FIG. 13

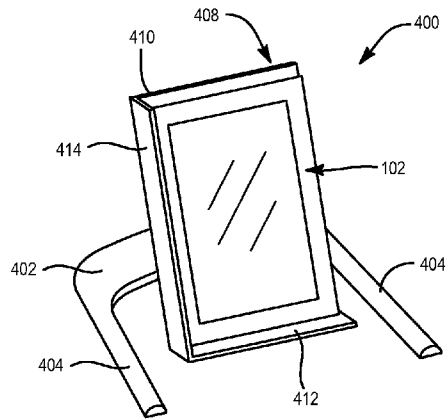

FIG. 14

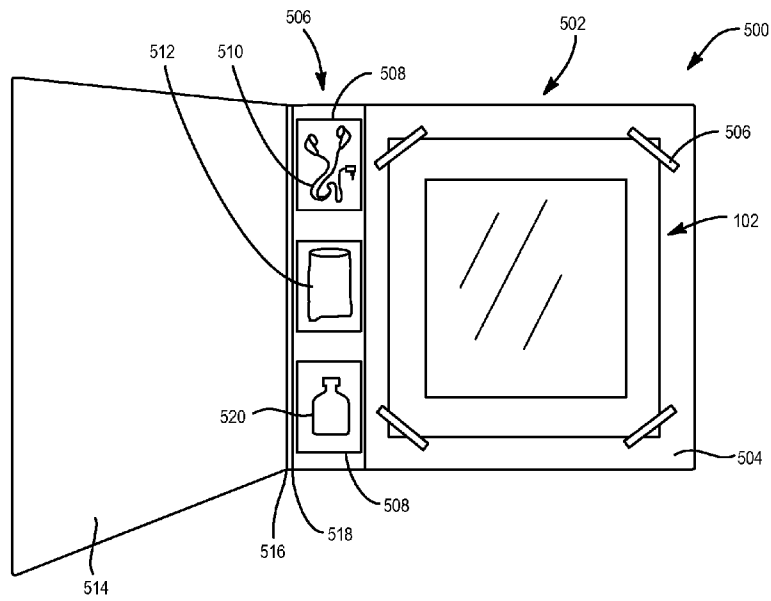

FIG. 15

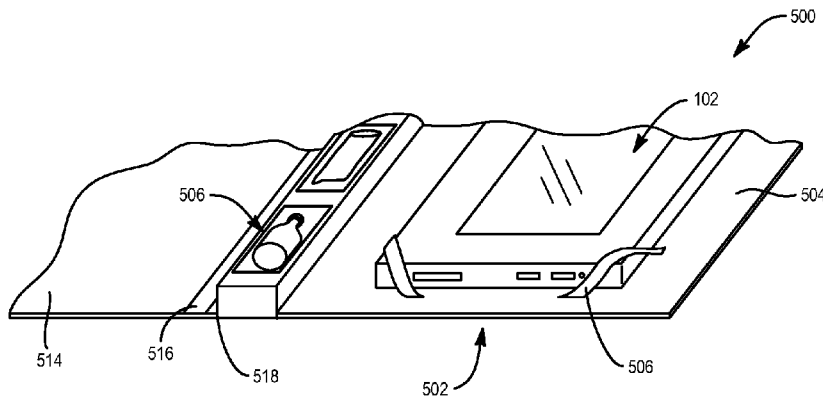

FIG. 16

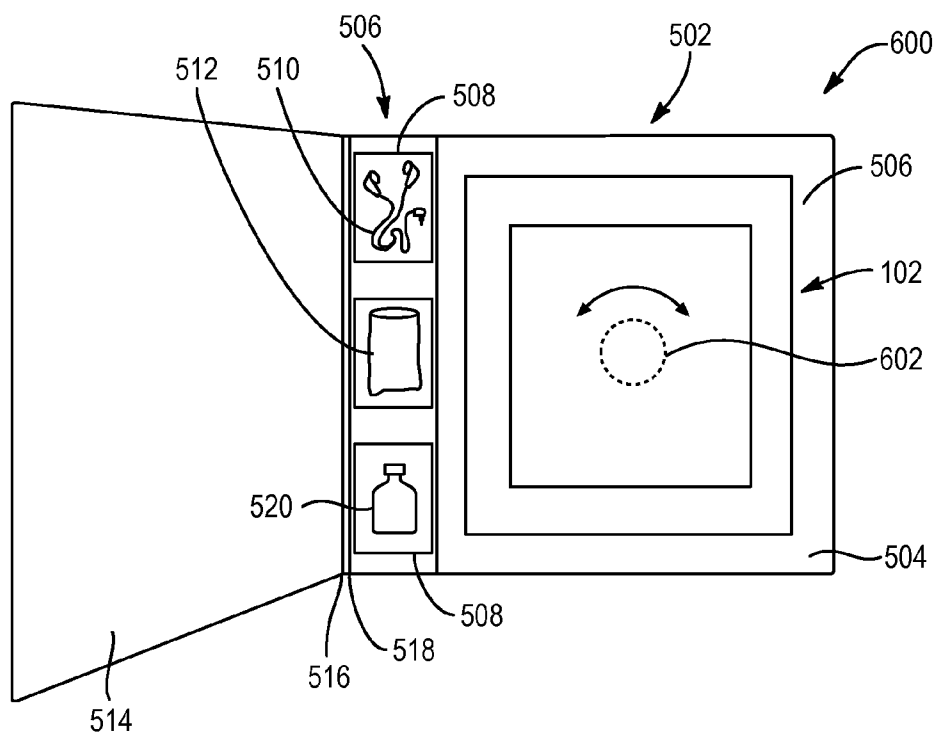

FIG. 17

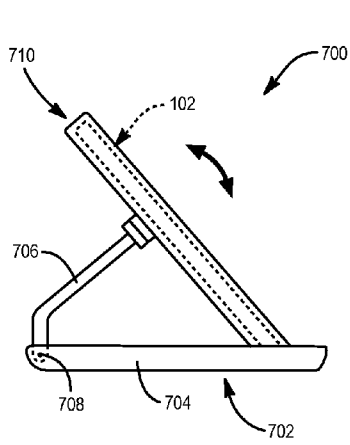

FIG. 18

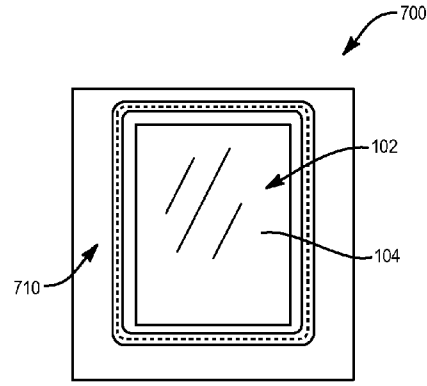

FIG. 19

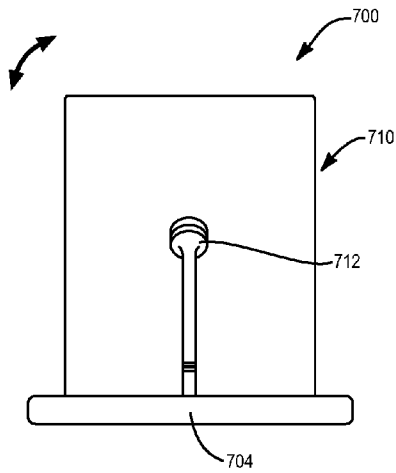

FIG. 20

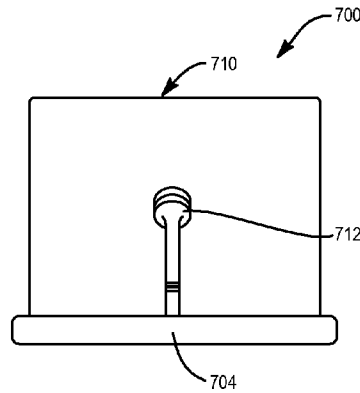

FIG. 21

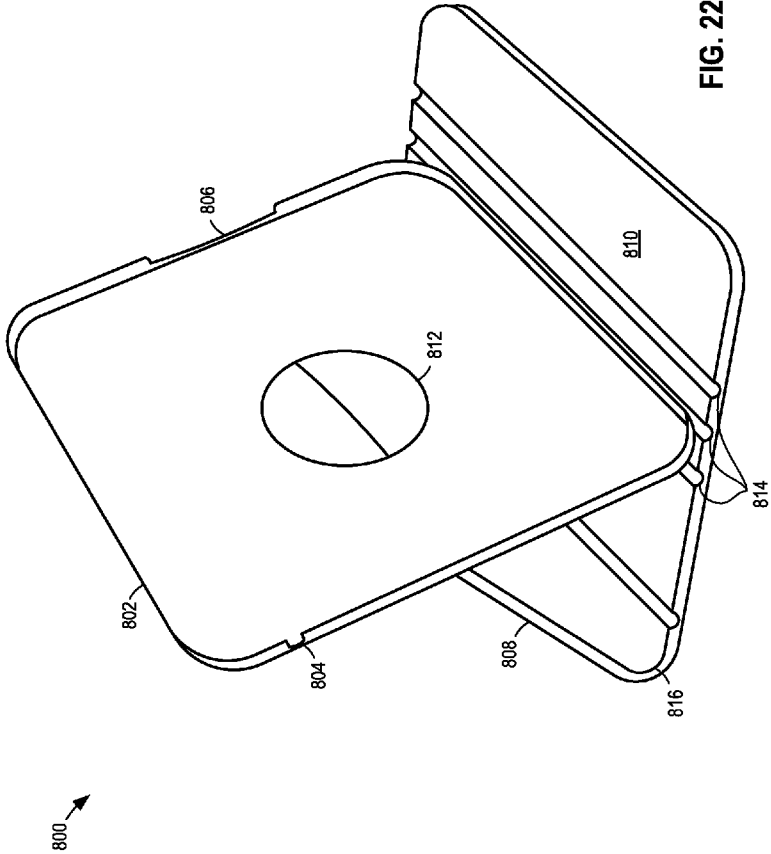
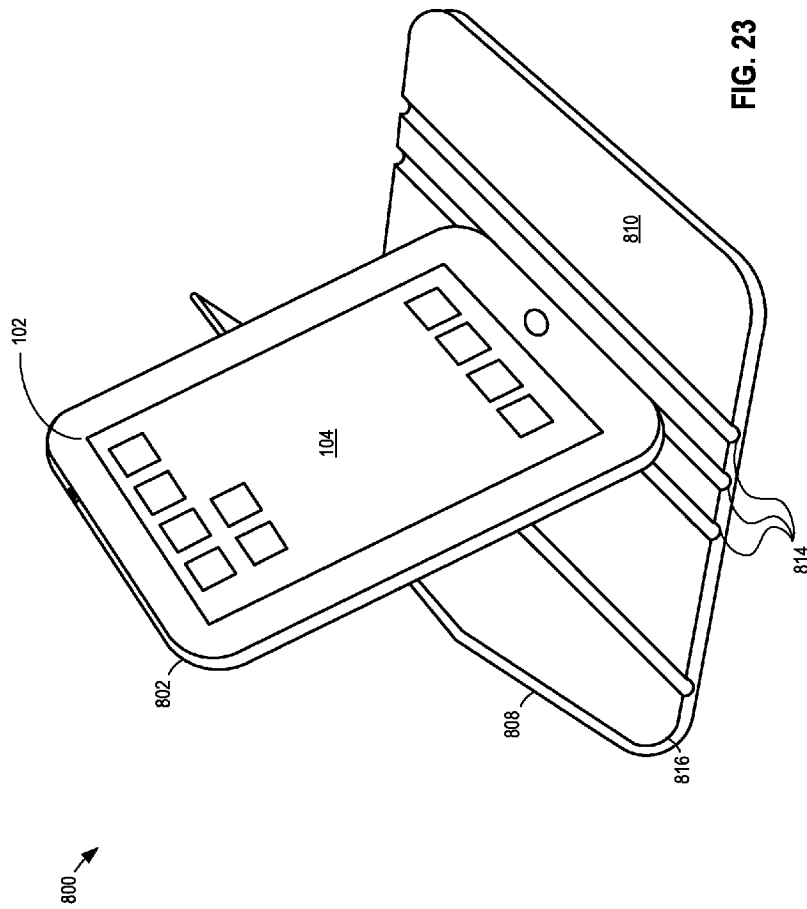

FIG. 22



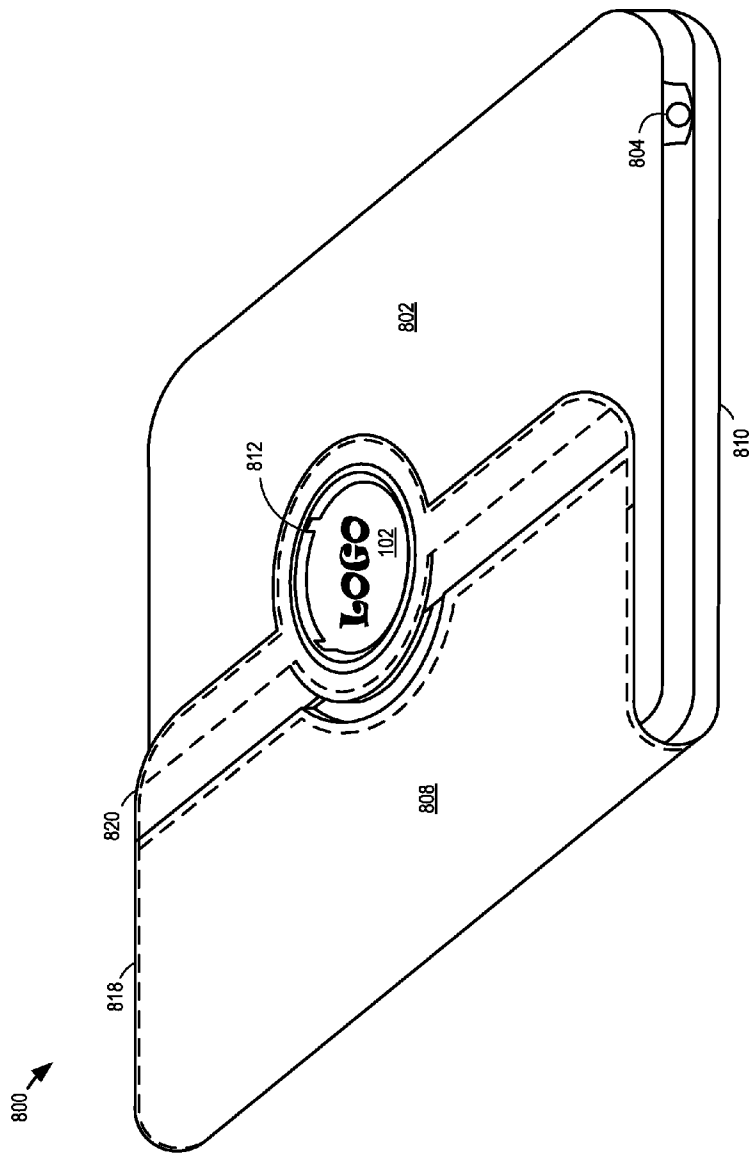
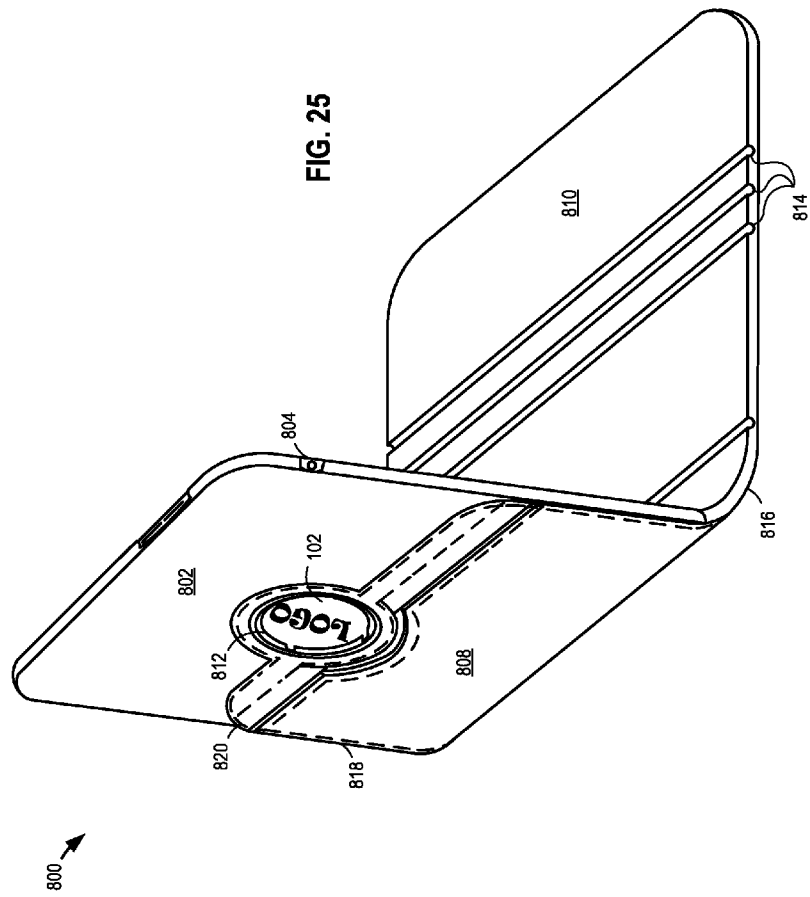
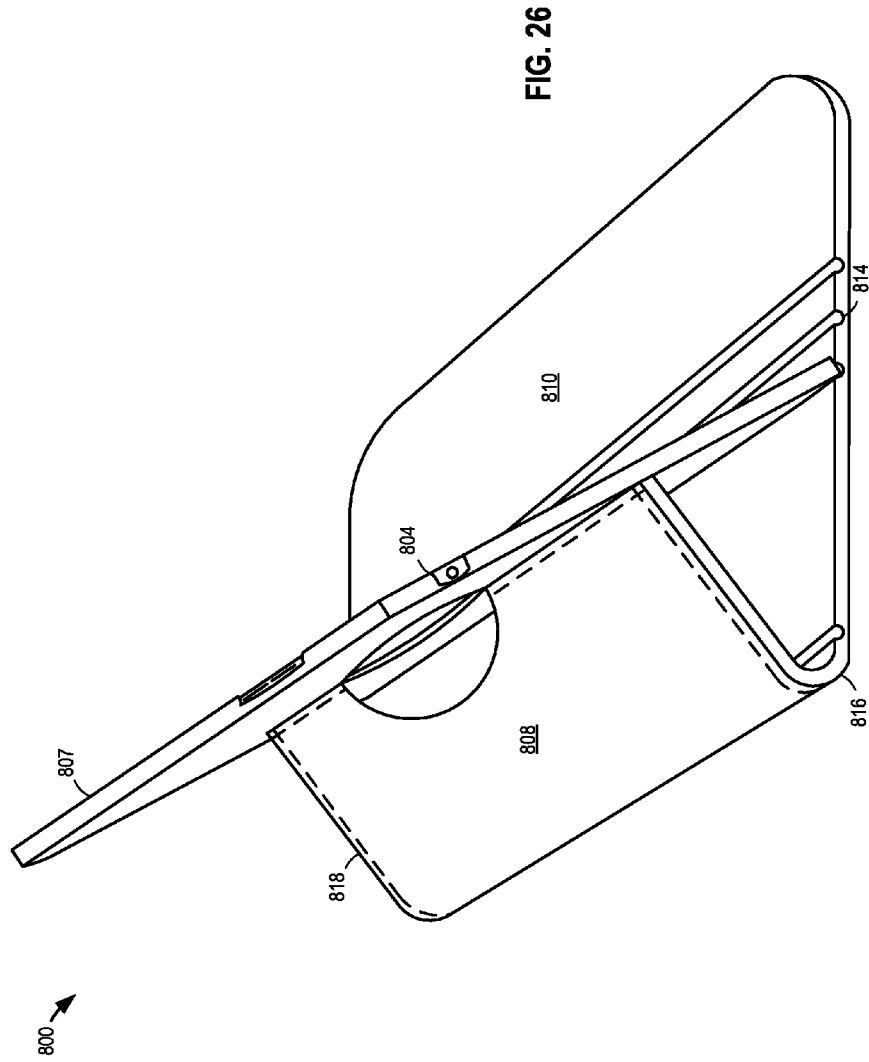
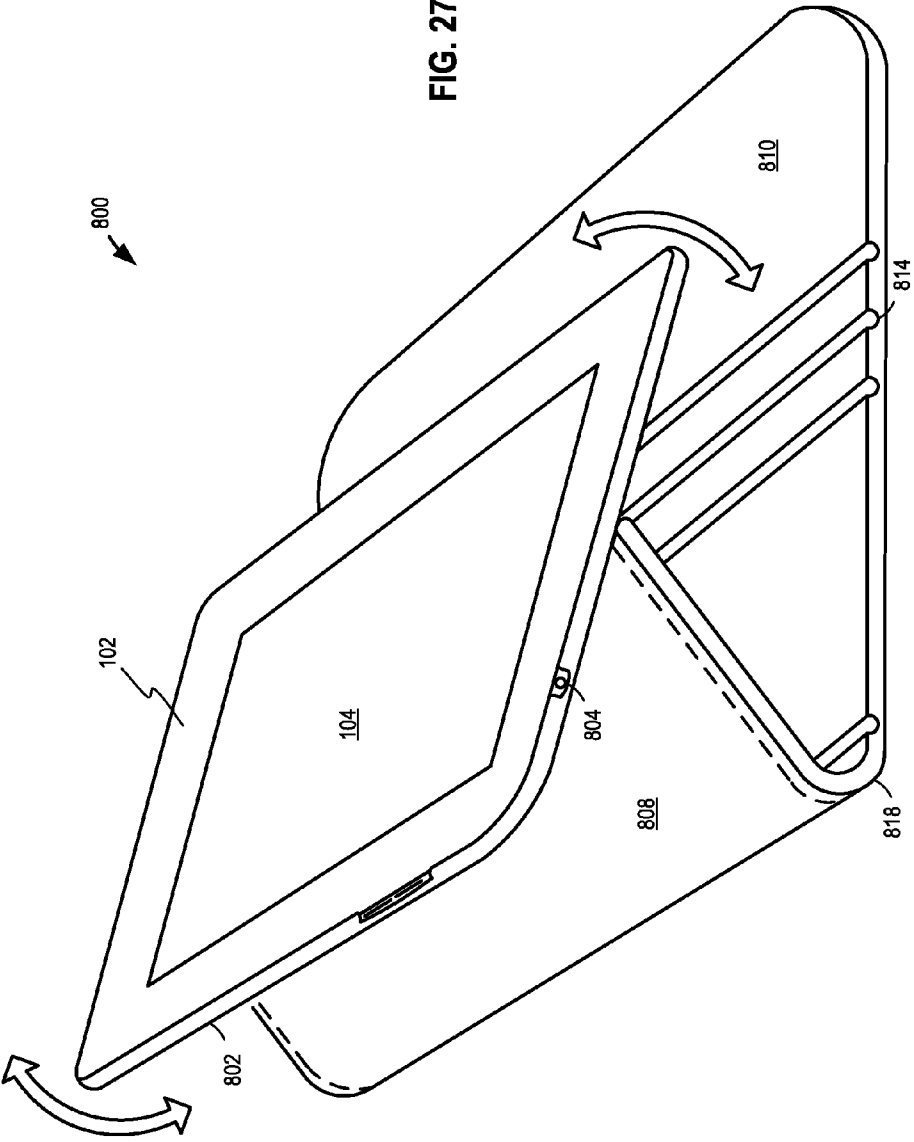

FIG. 24







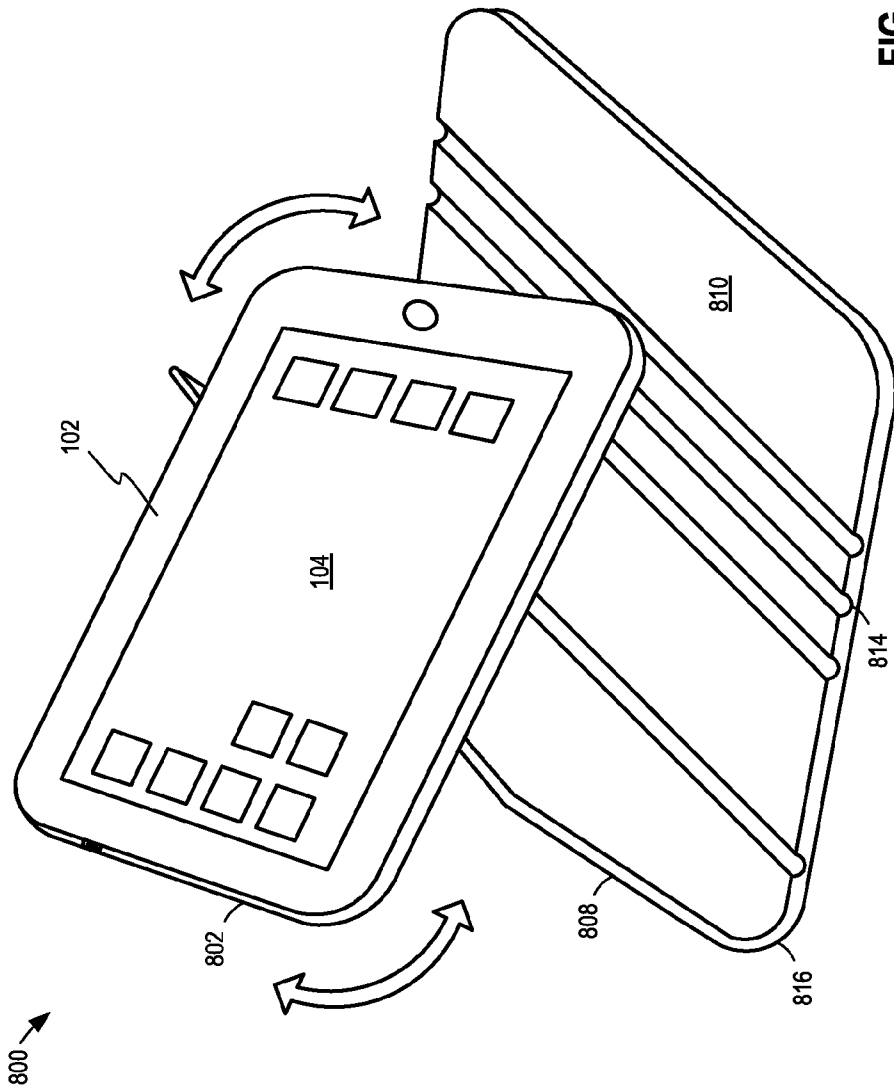

FIG. 28

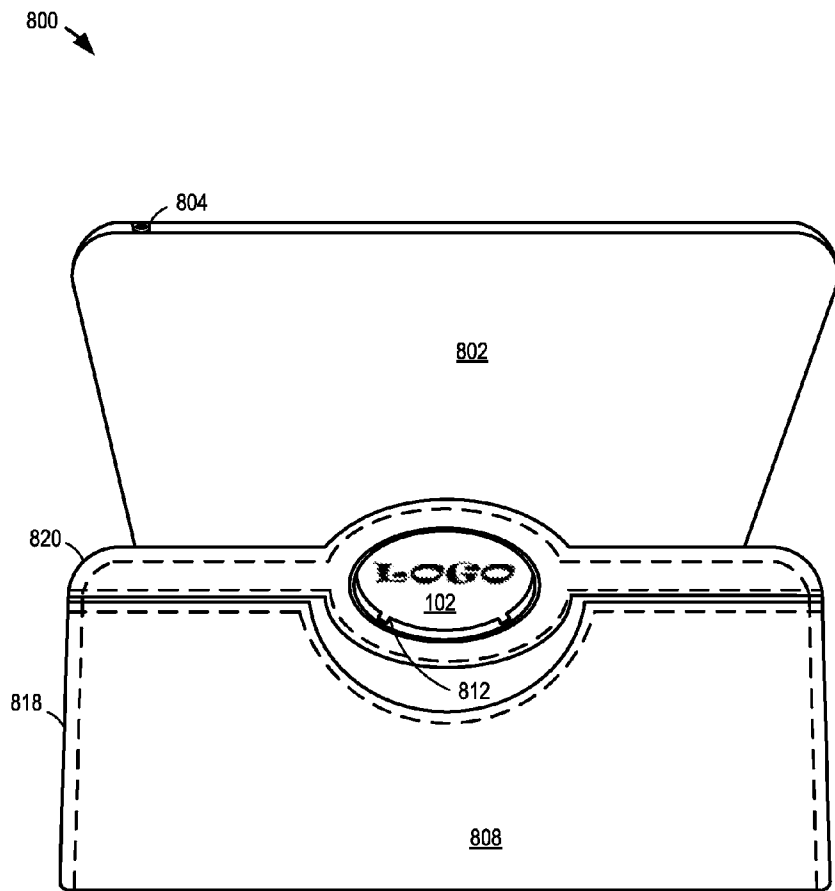

FIG. 29

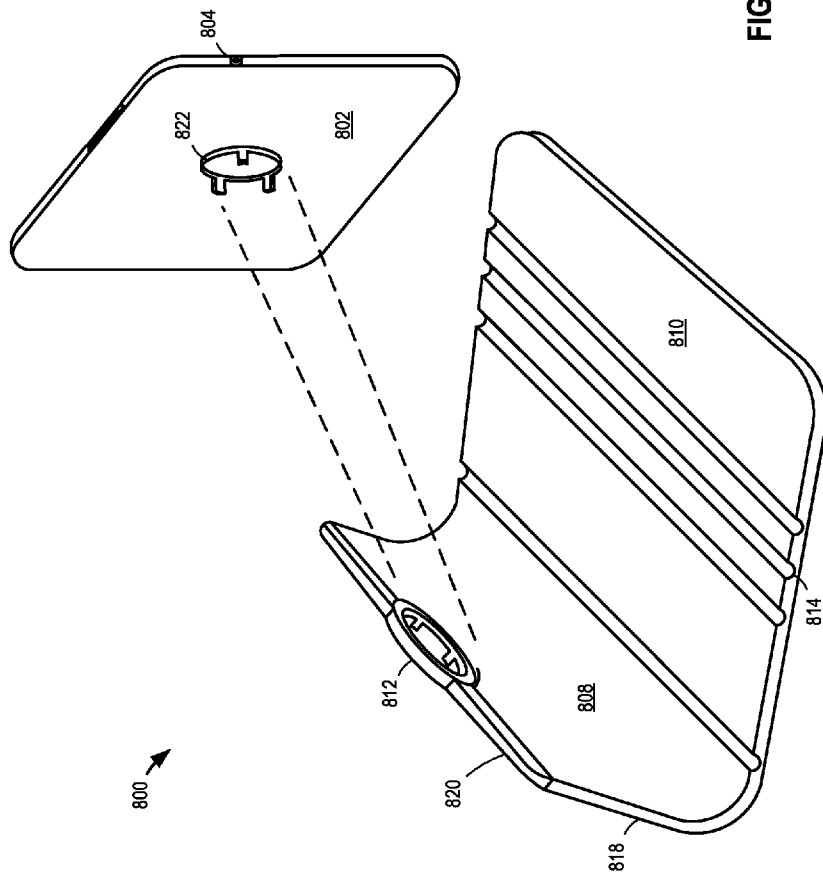

FIG. 30

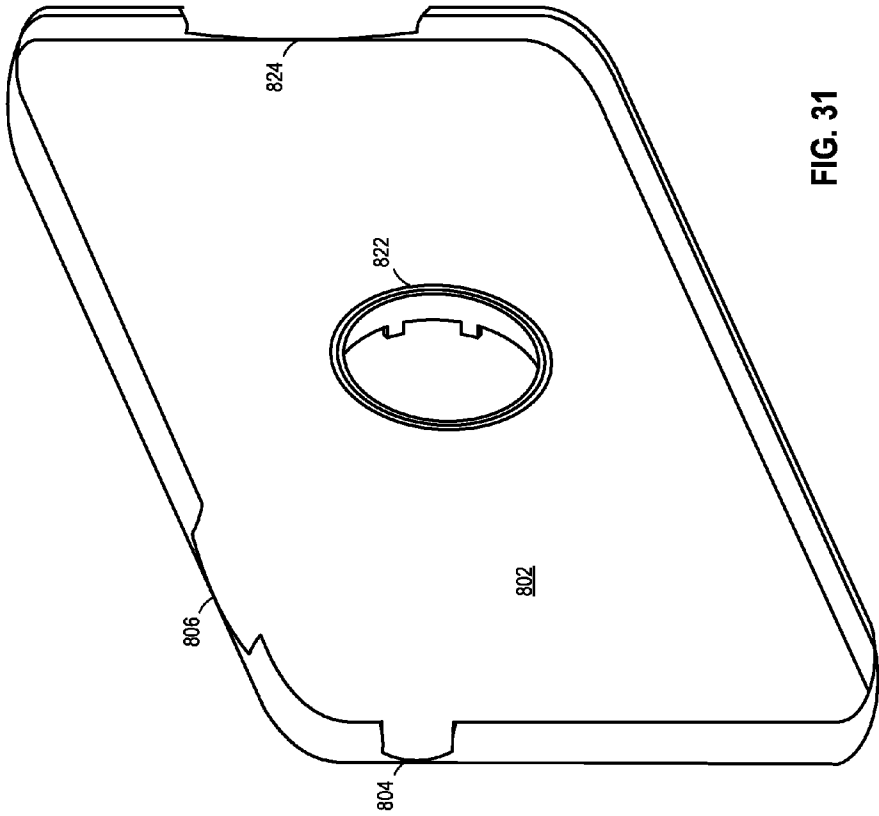

FIG. 31

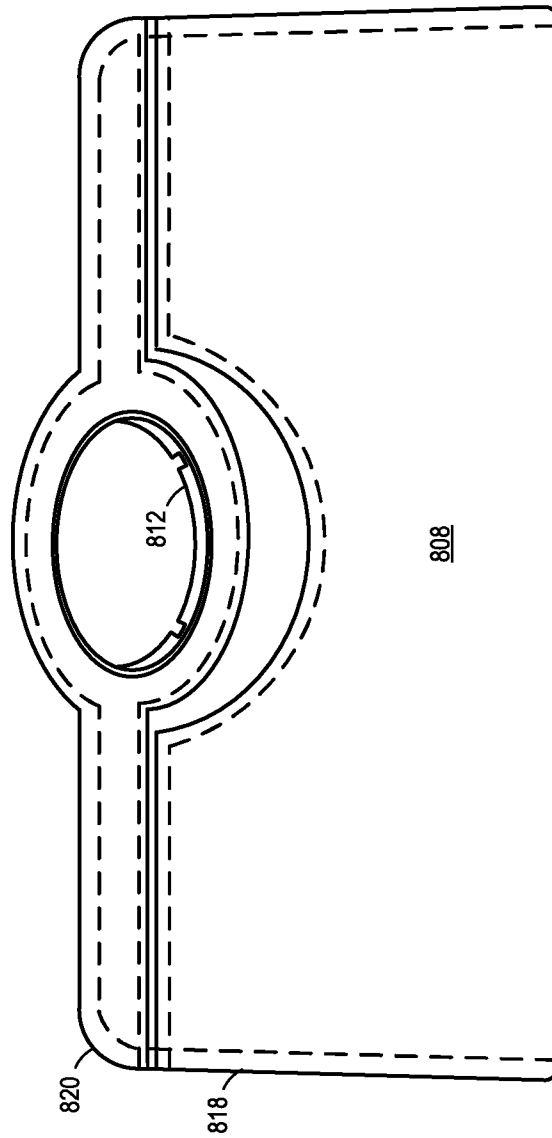

FIG. 32

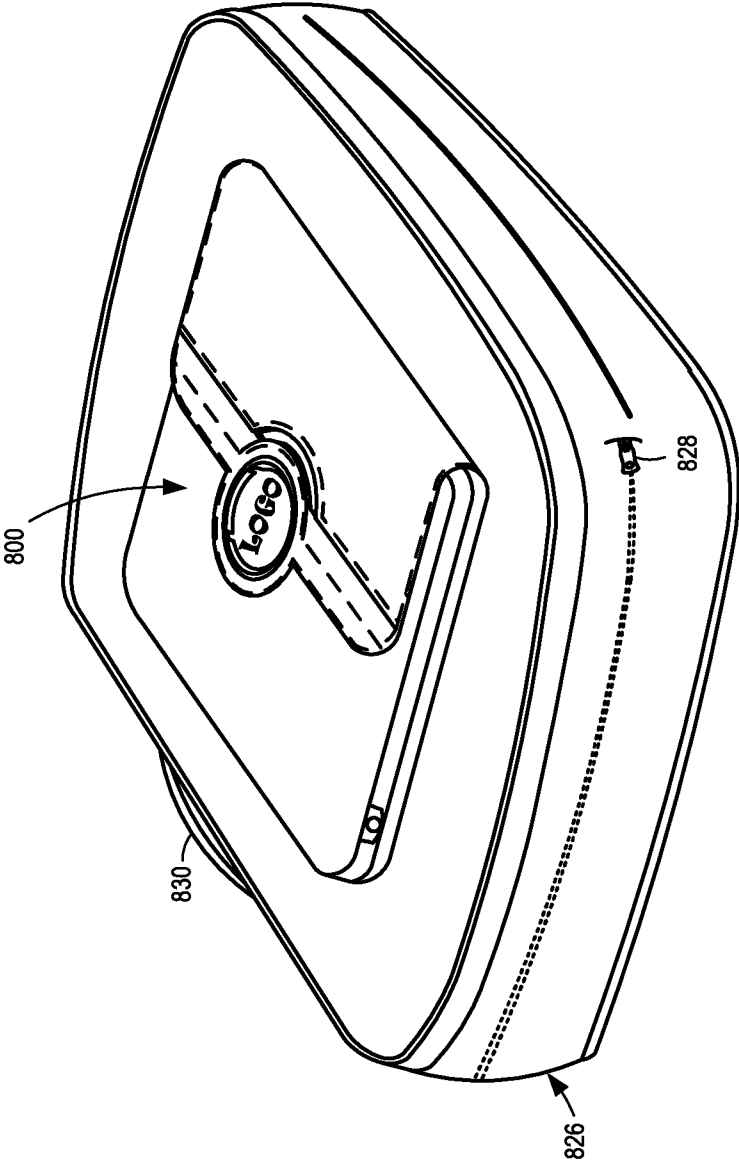

FIG. 33

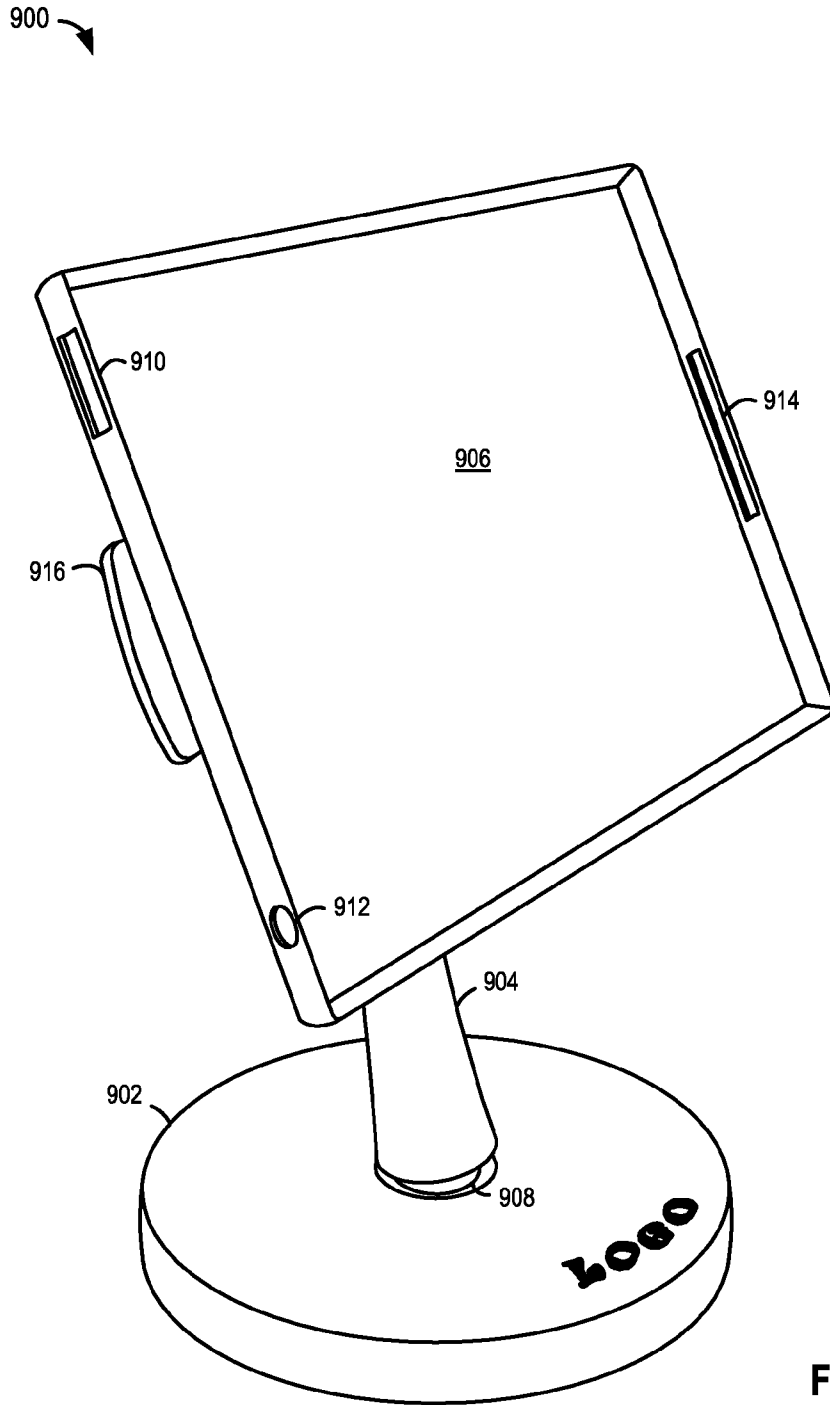

FIG. 34

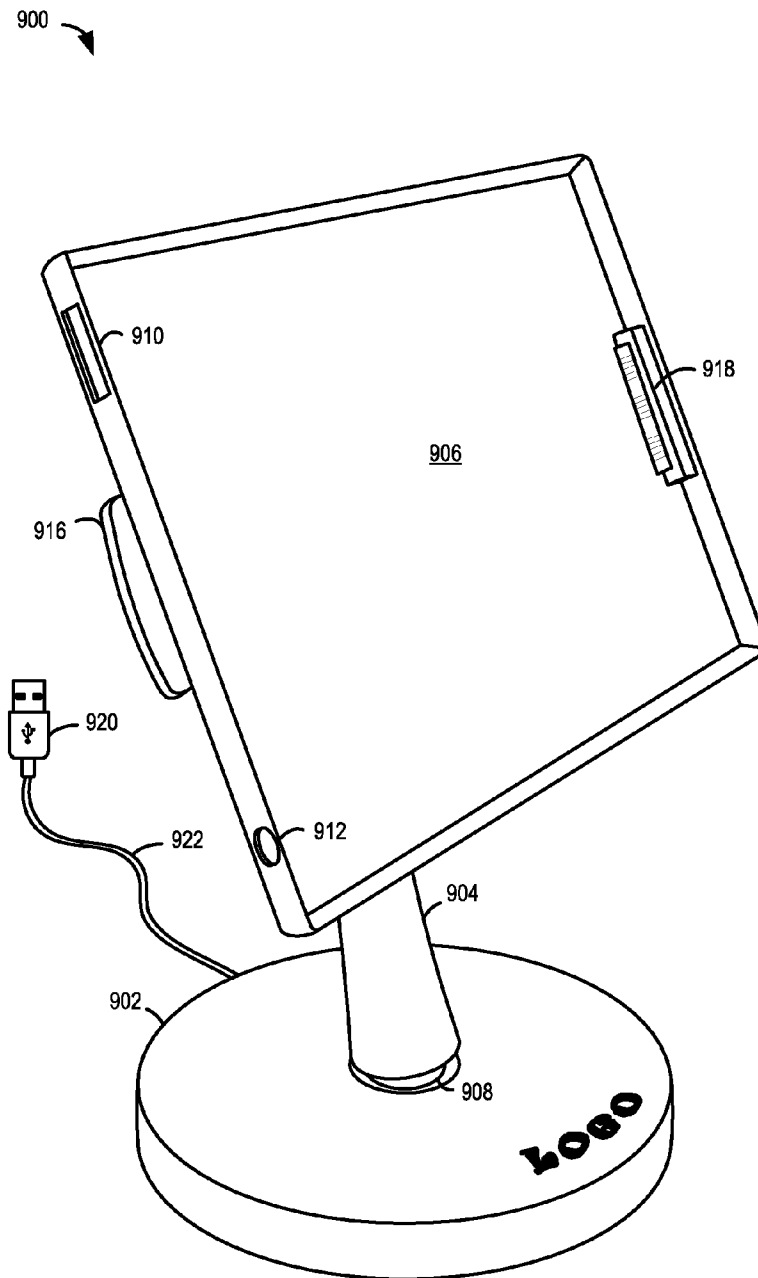

FIG. 35

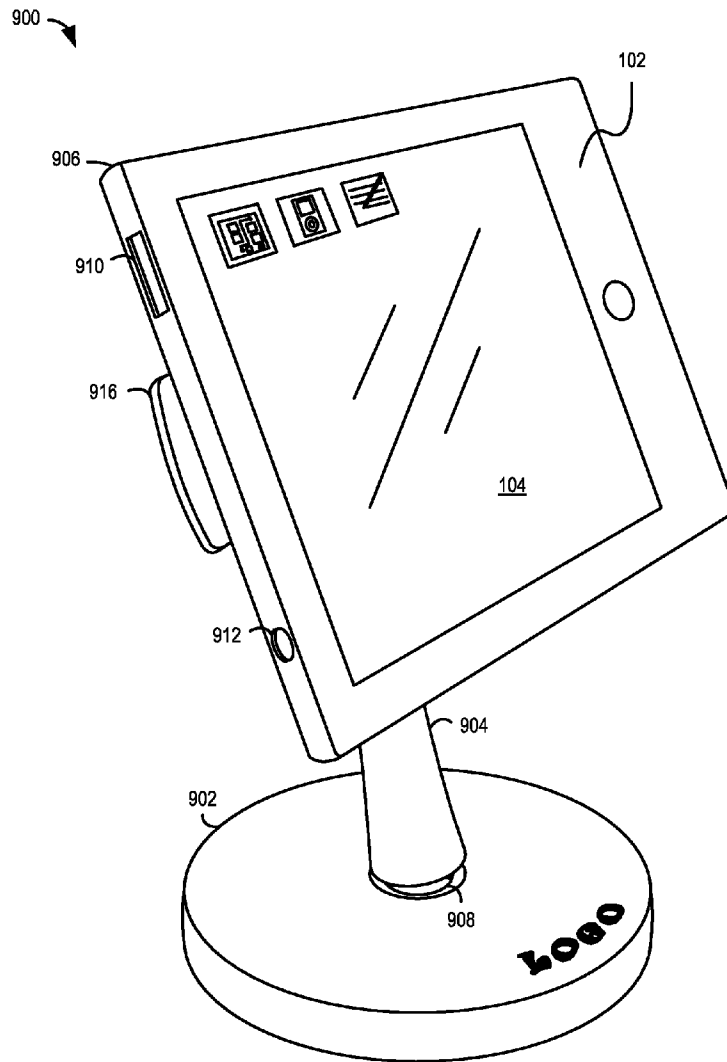

FIG. 36

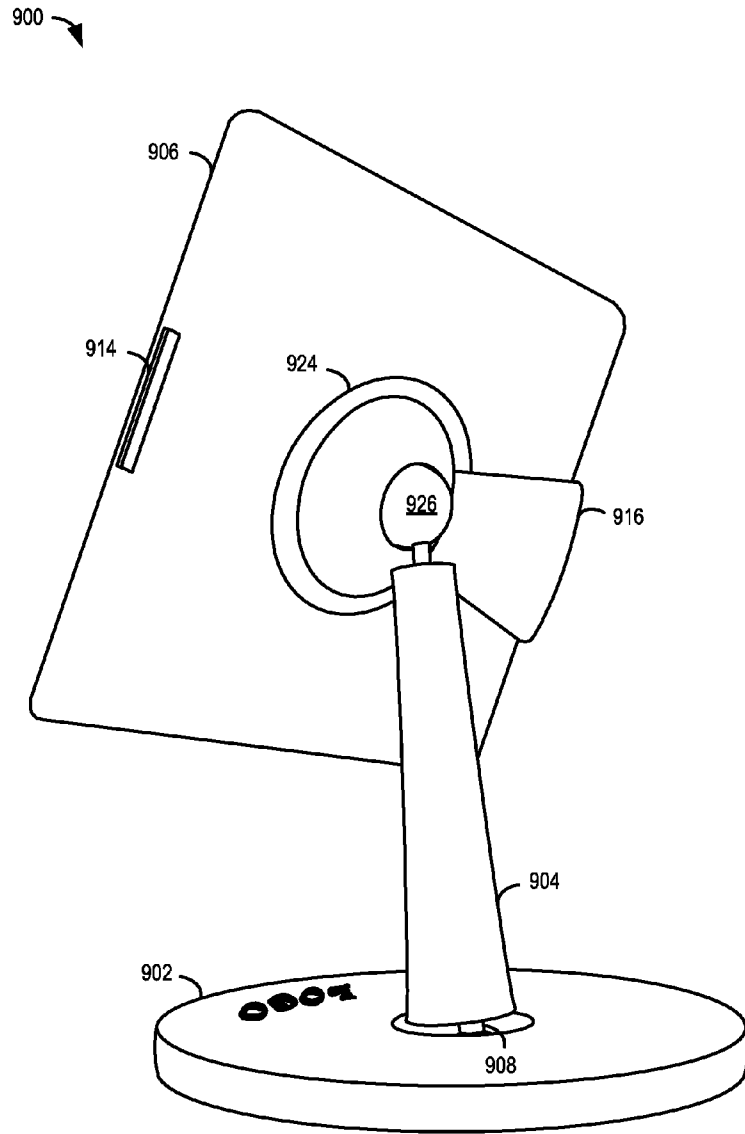

FIG. 37

900 ↗

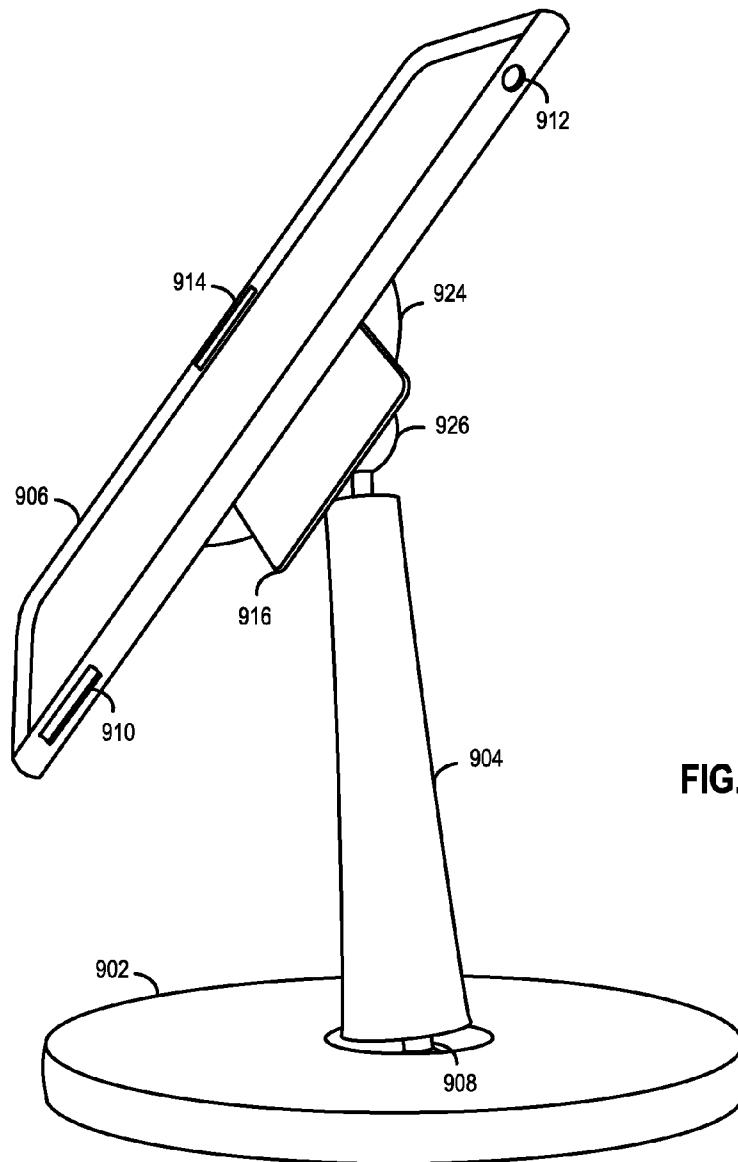

FIG. 38

900 ↗

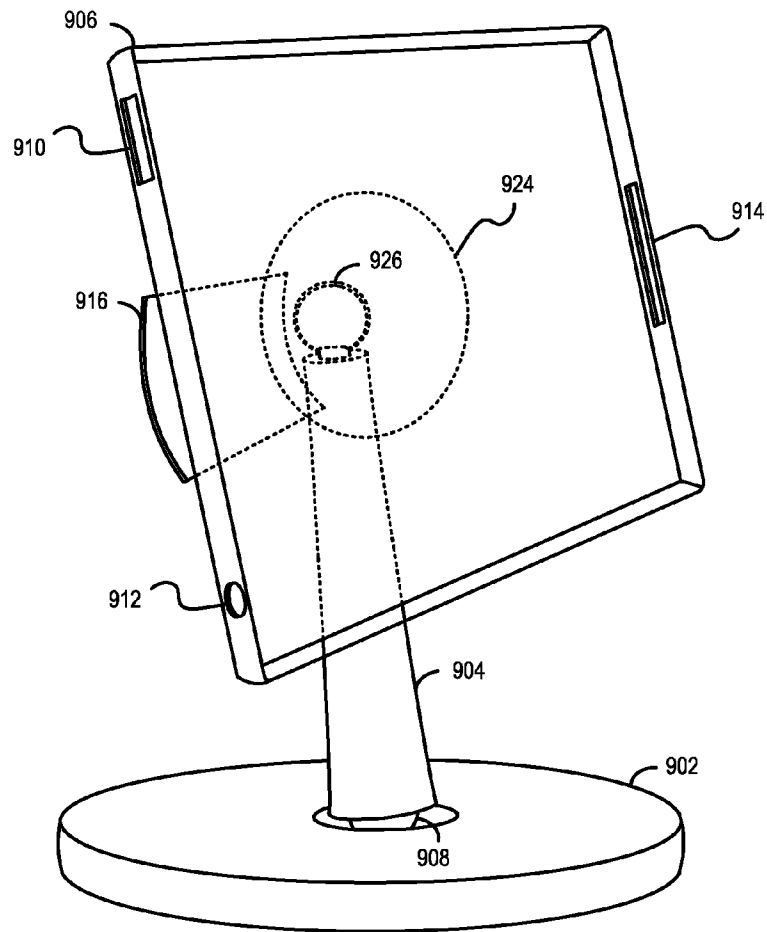

FIG. 39

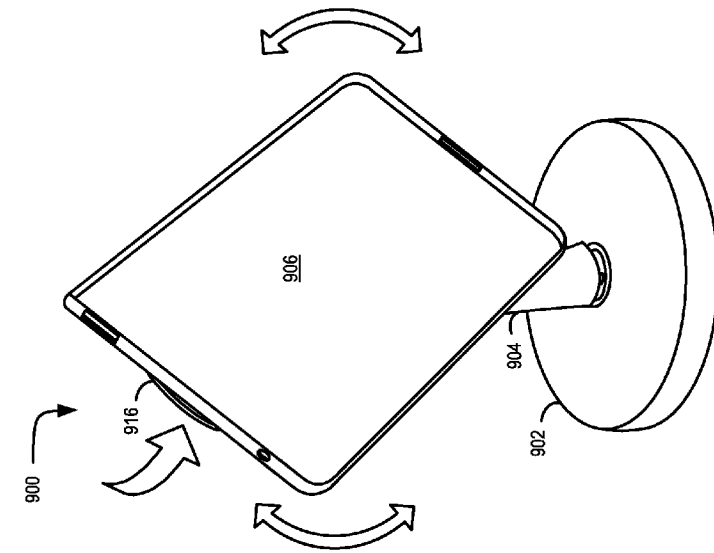

FIG. 41

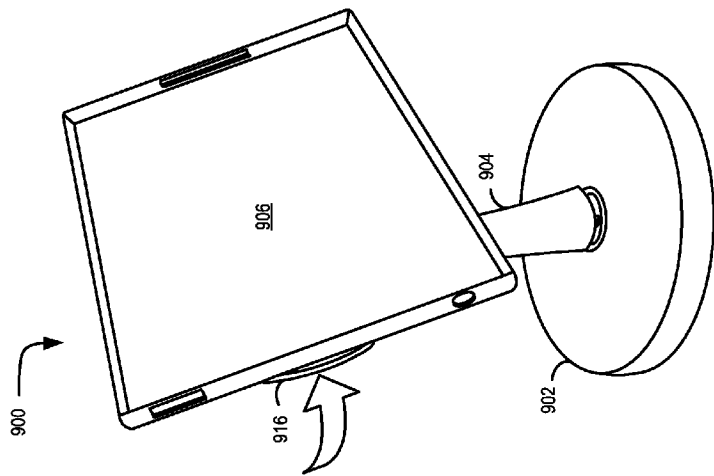

FIG. 40

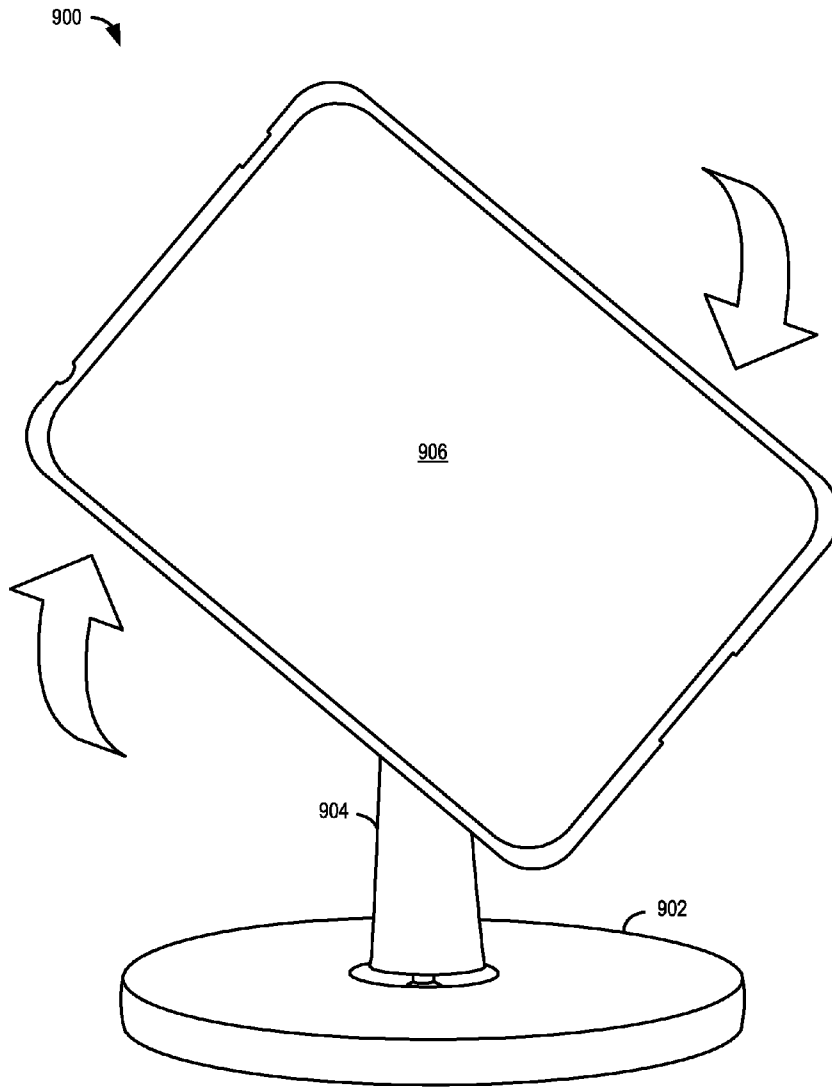

FIG. 42

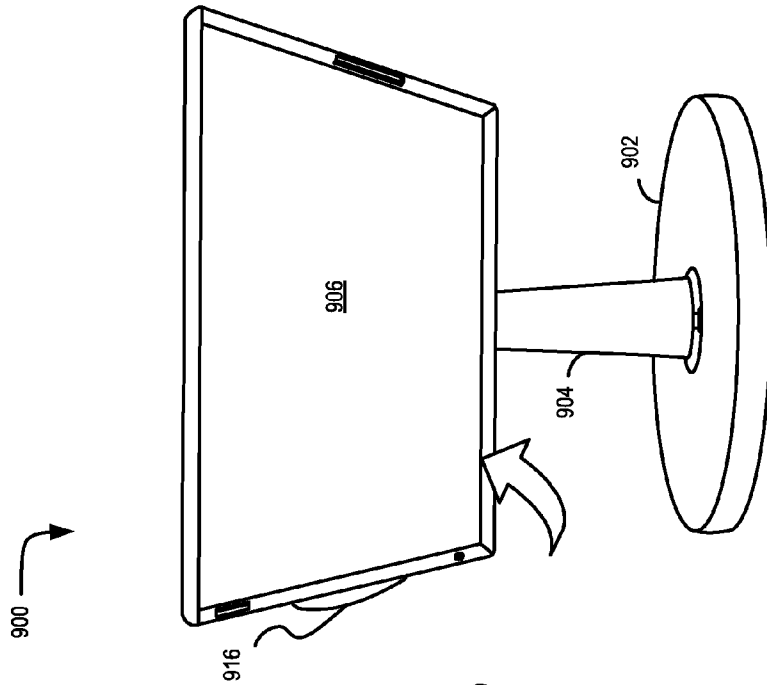

FIG. 43

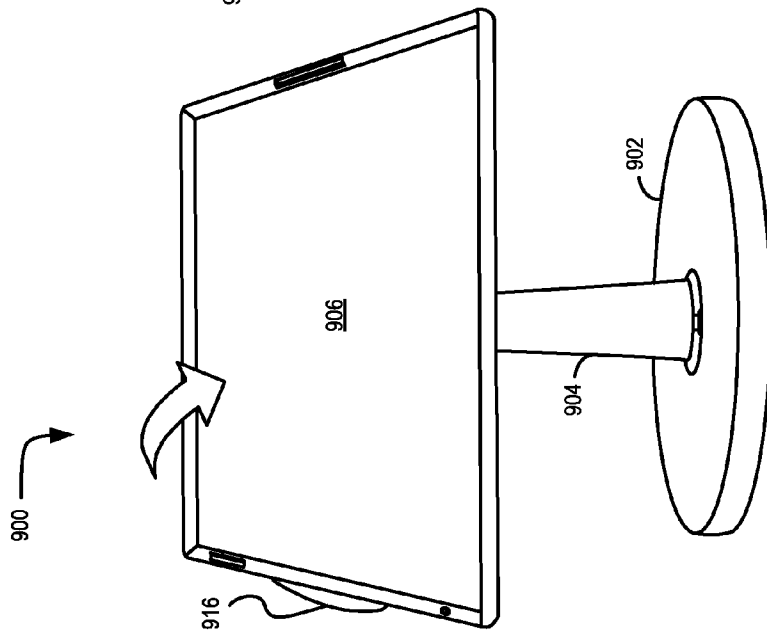

FIG. 44

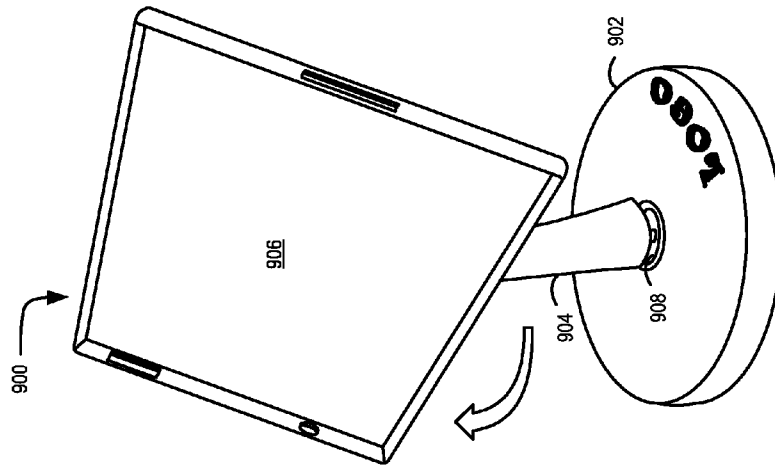

FIG. 46

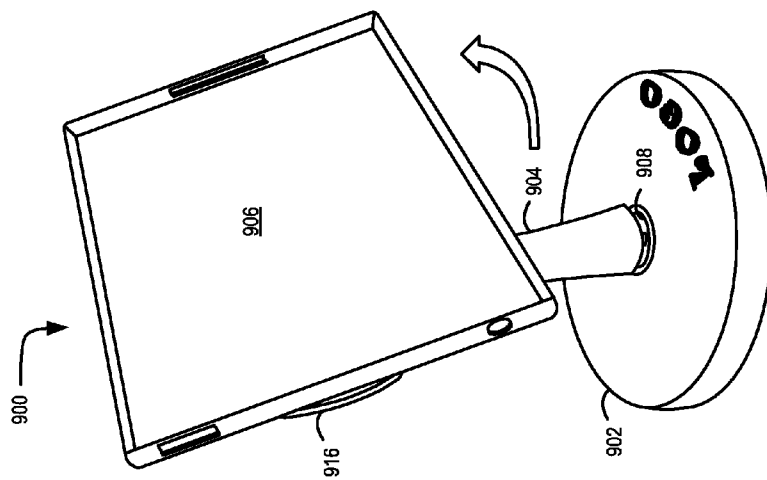

FIG. 45

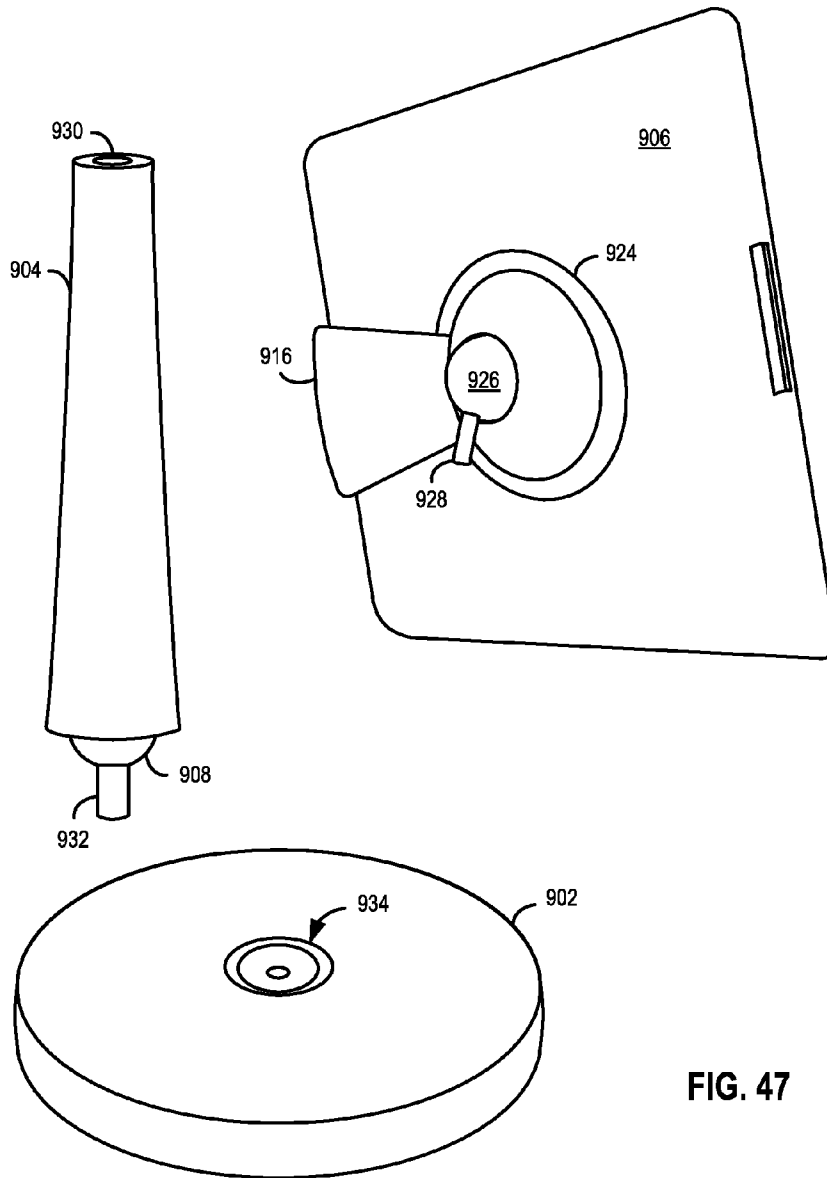

FIG. 47

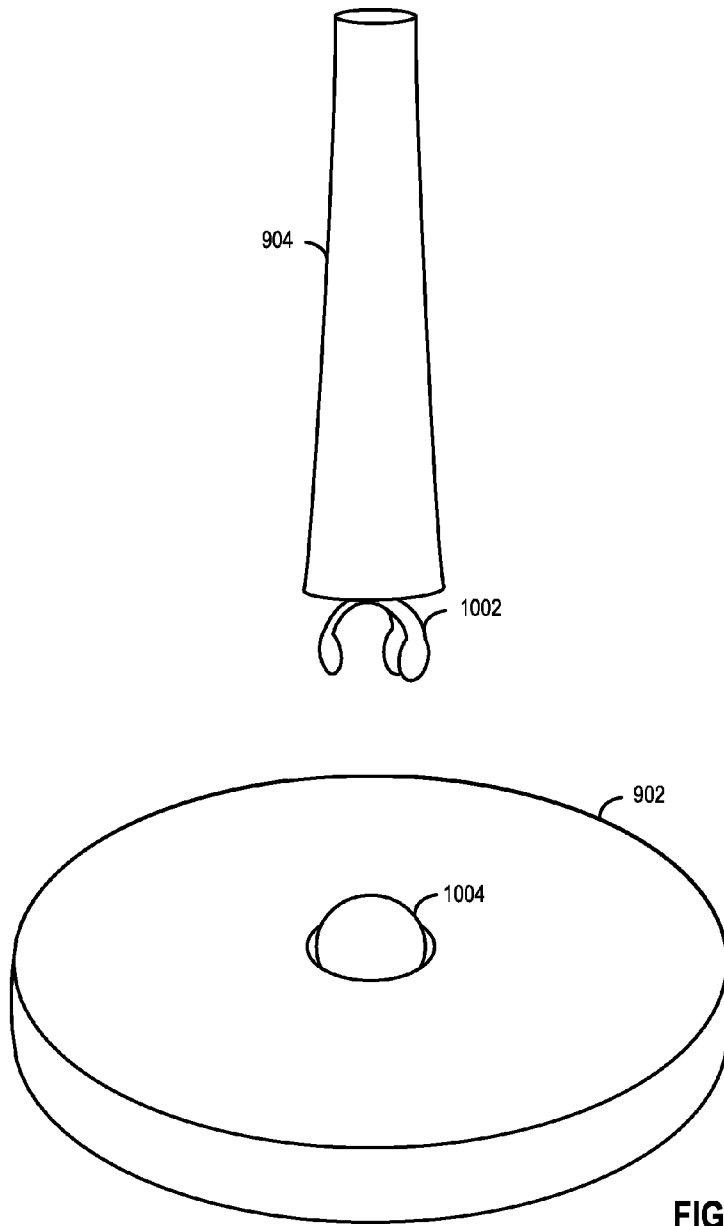

FIG. 48

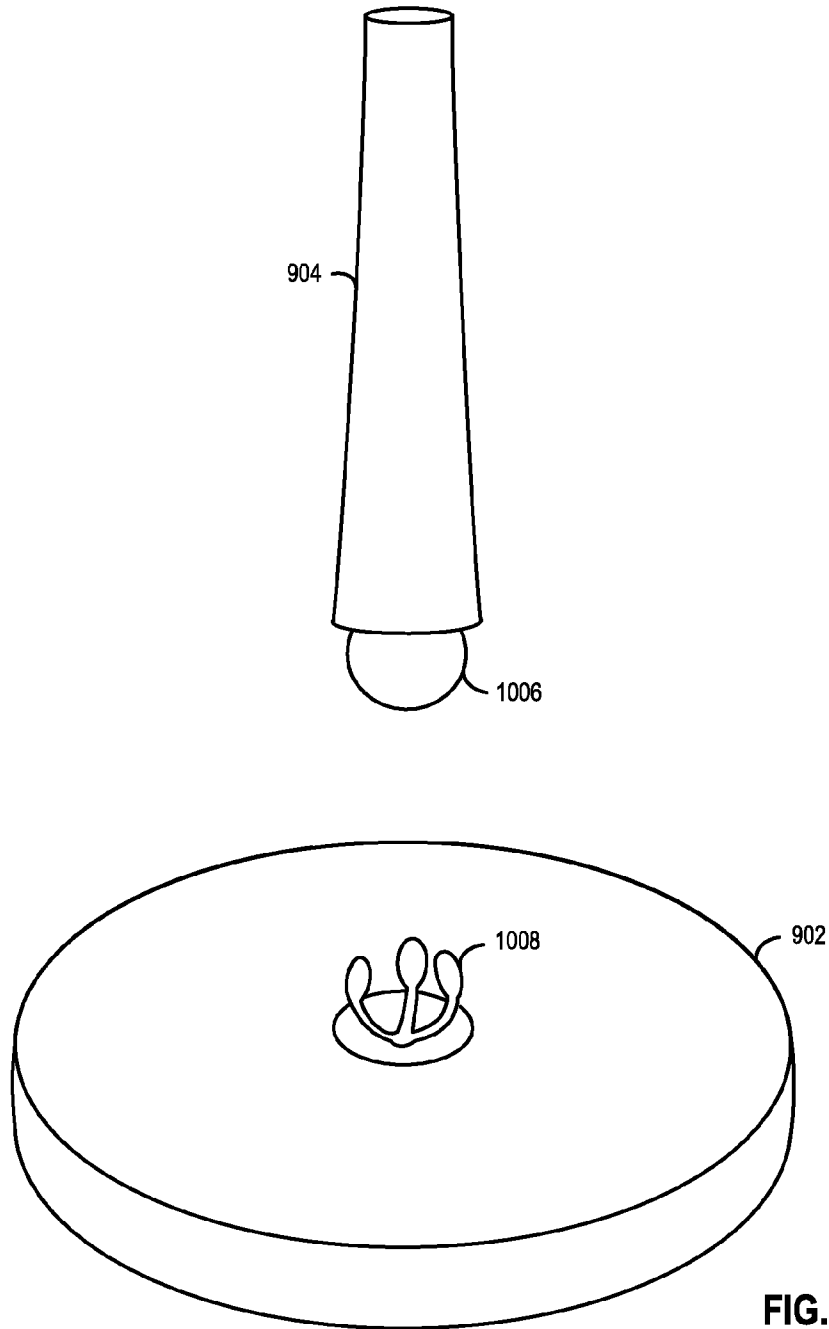

FIG. 49

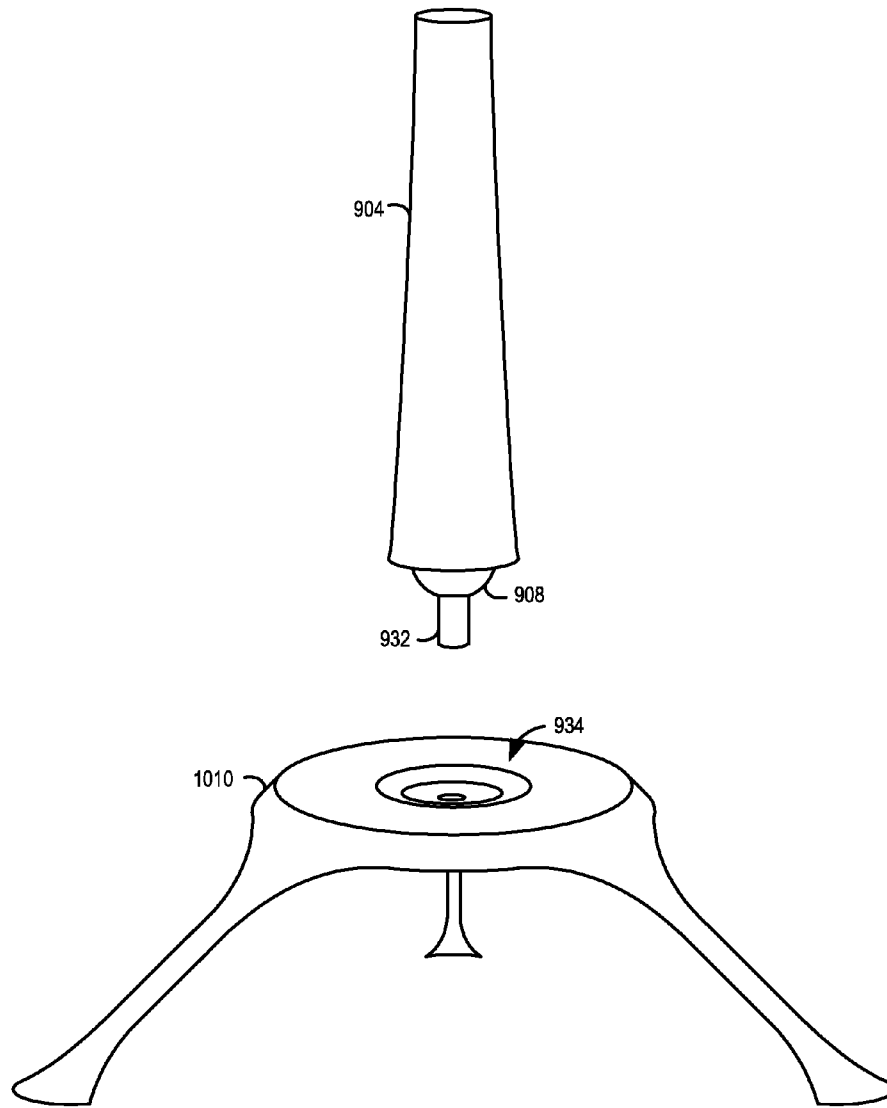

FIG. 50

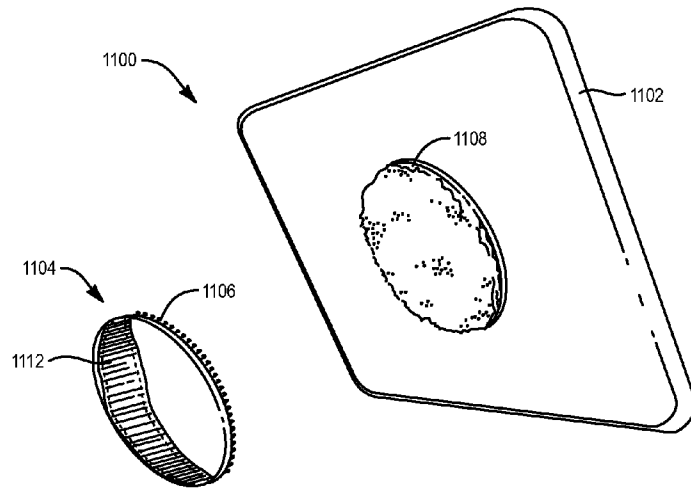

FIG. 51

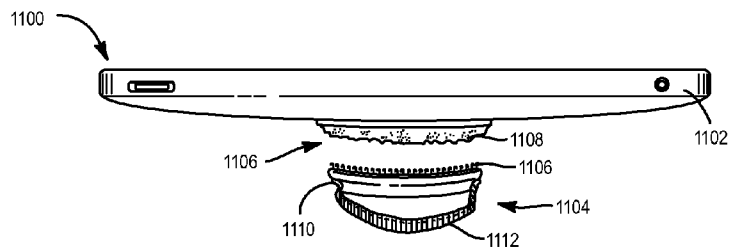

FIG. 52

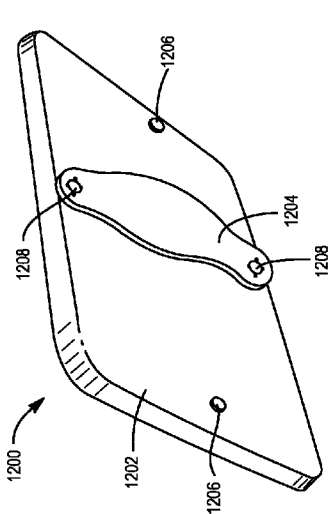

FIG. 54

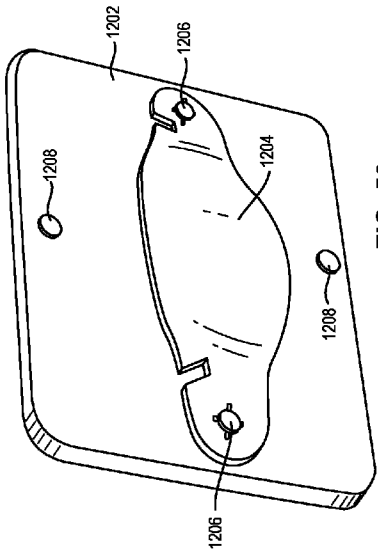

FIG. 56

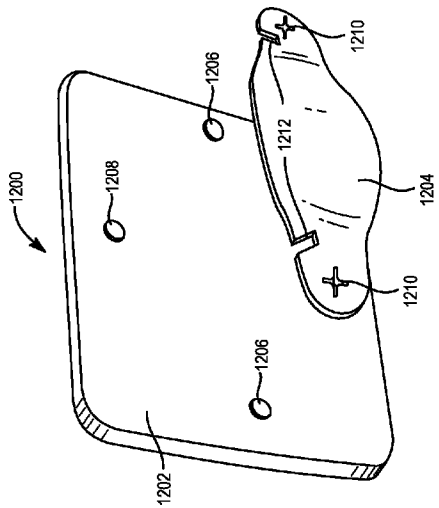

FIG. 53

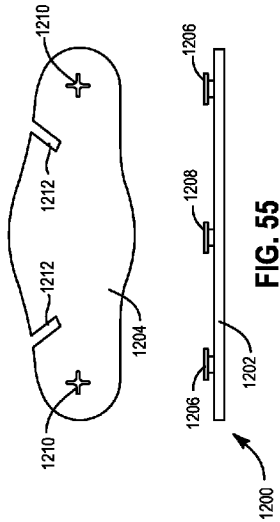

FIG. 55

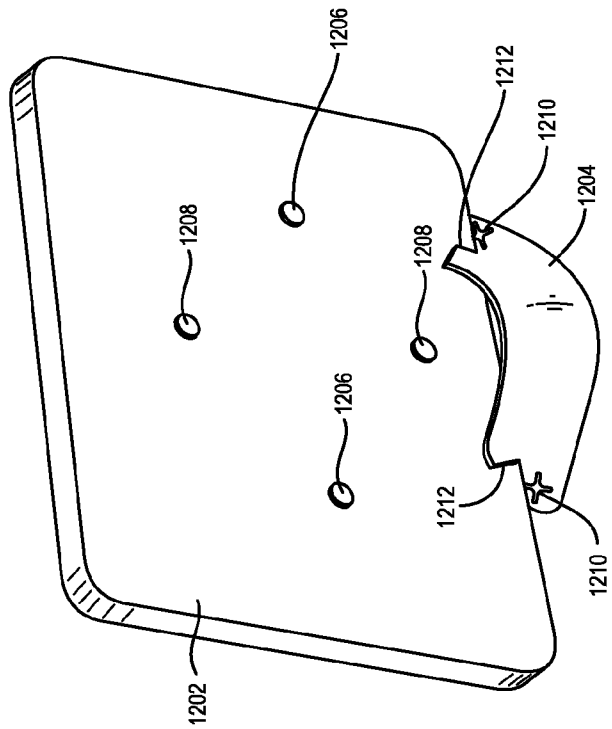

FIG. 57

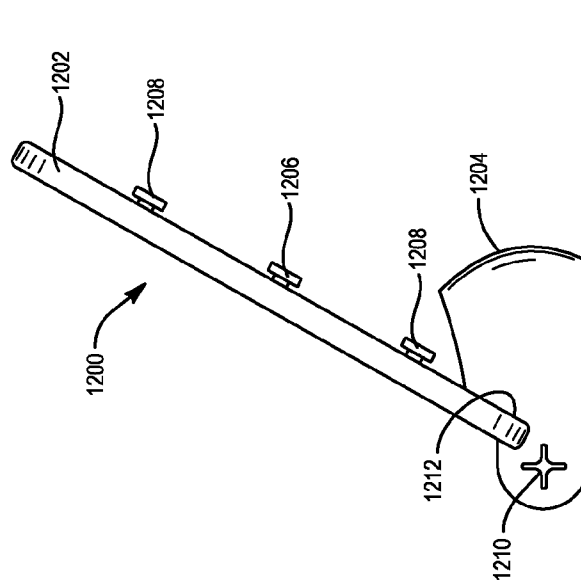

FIG. 58

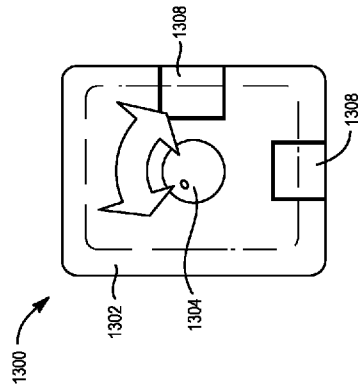

FIG. 60

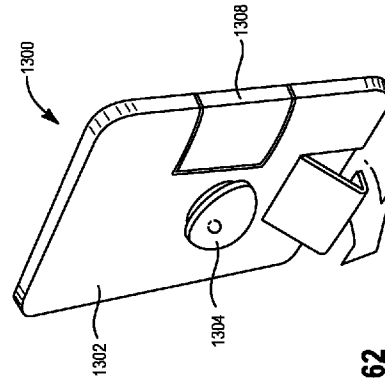

FIG. 62

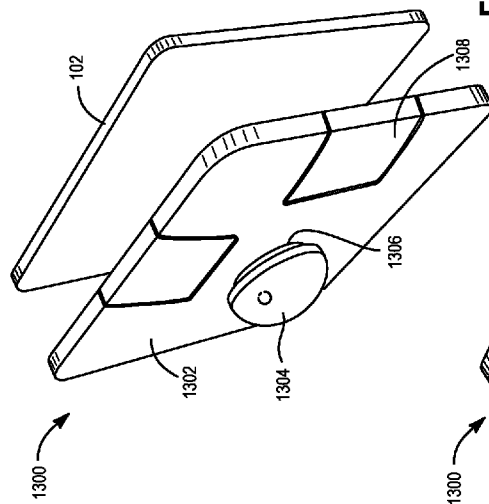

FIG. 59

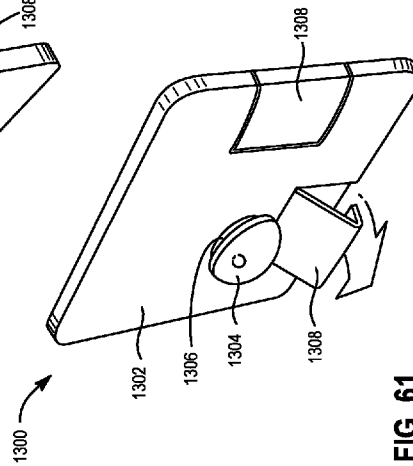

FIG. 61

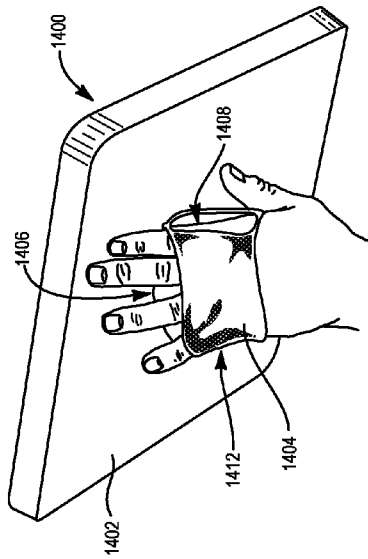

FIG. 64

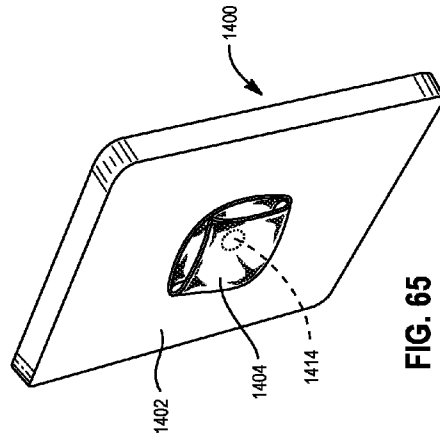

FIG. 65

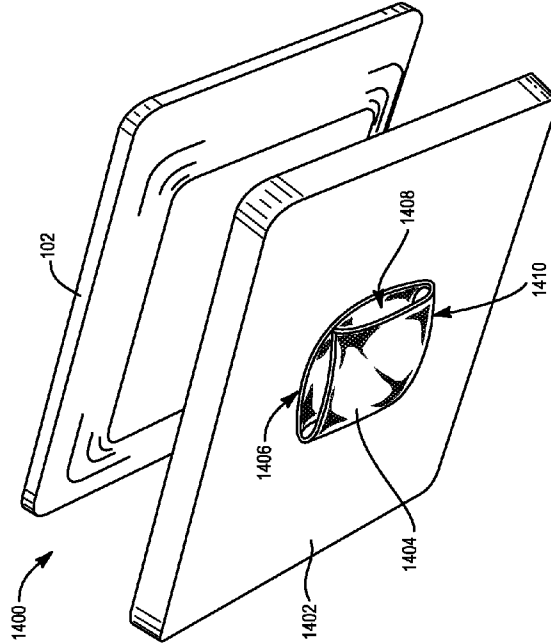

FIG. 63

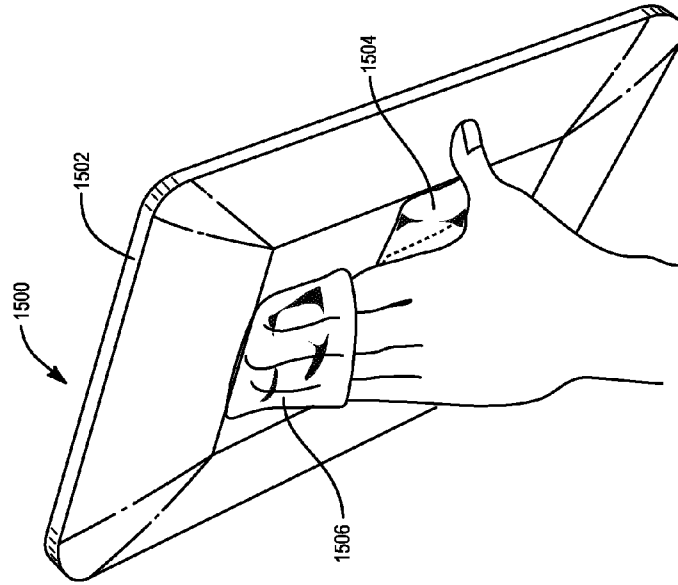

FIG. 67

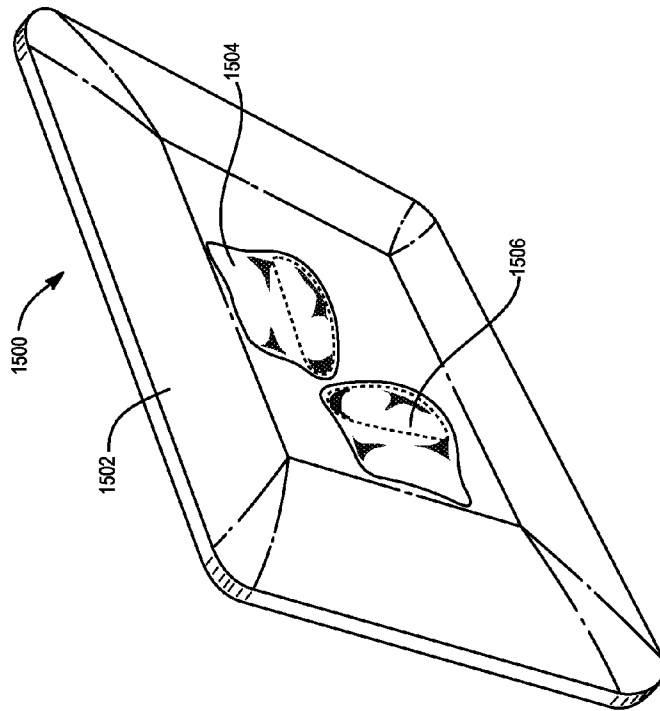

FIG. 66

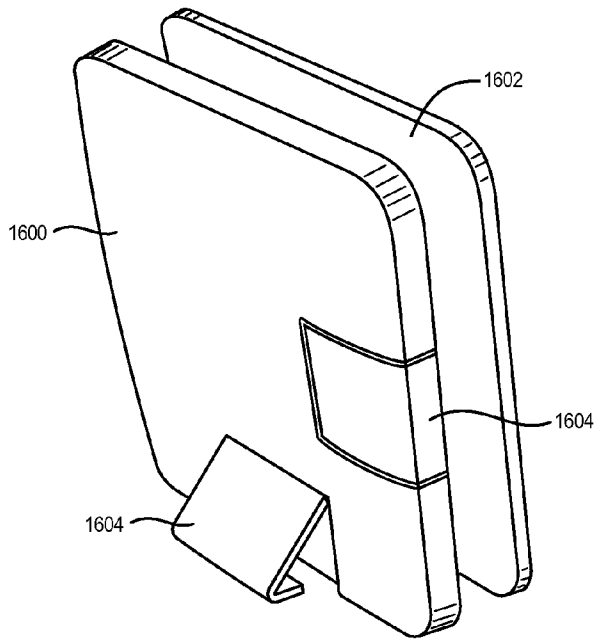

FIG. 68

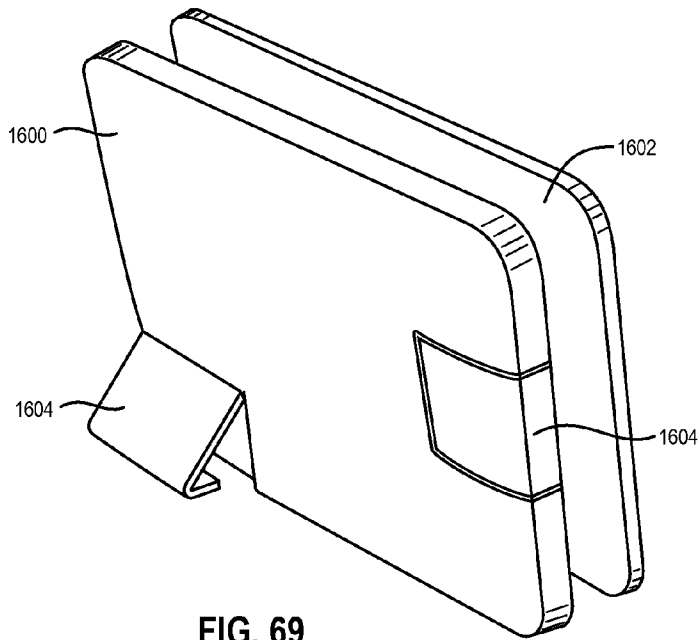

FIG. 69

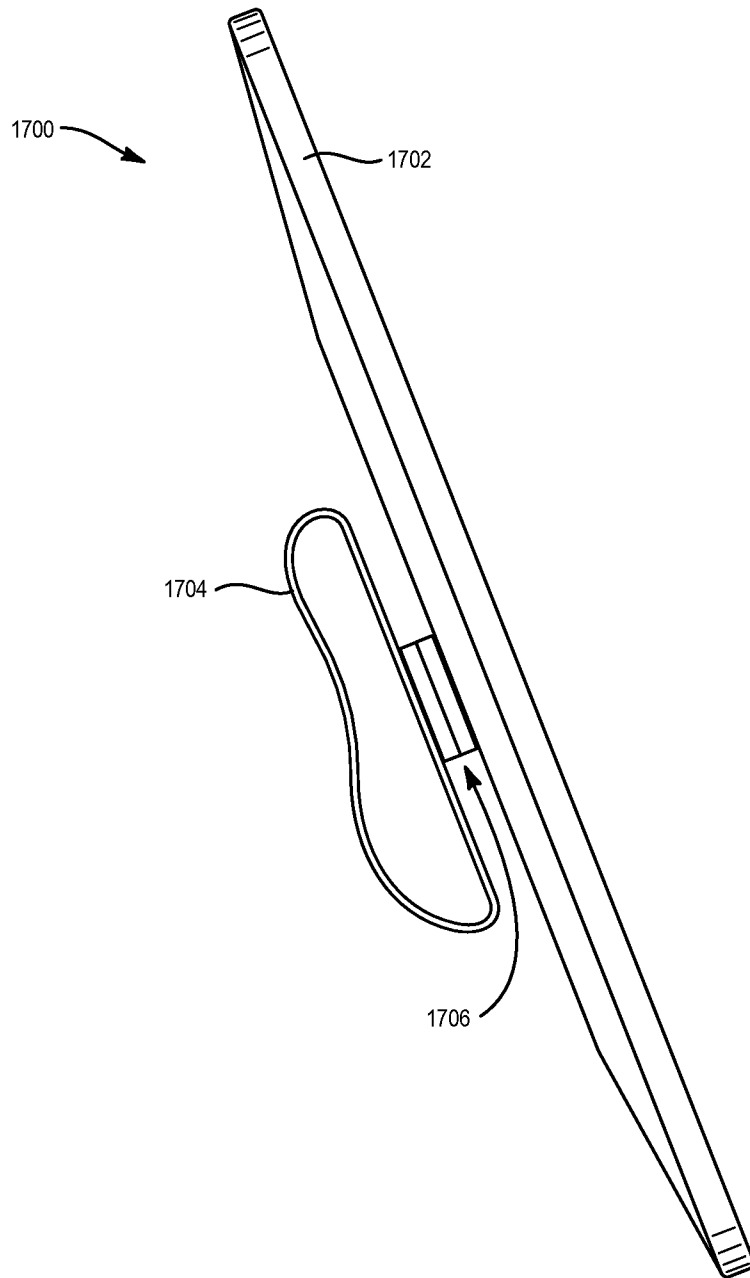

FIG. 70

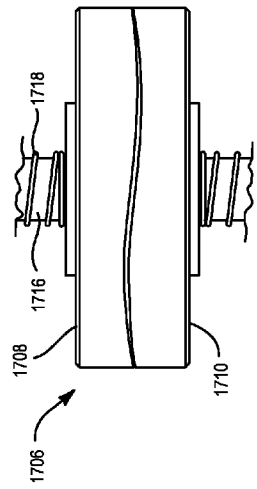

FIG. 72

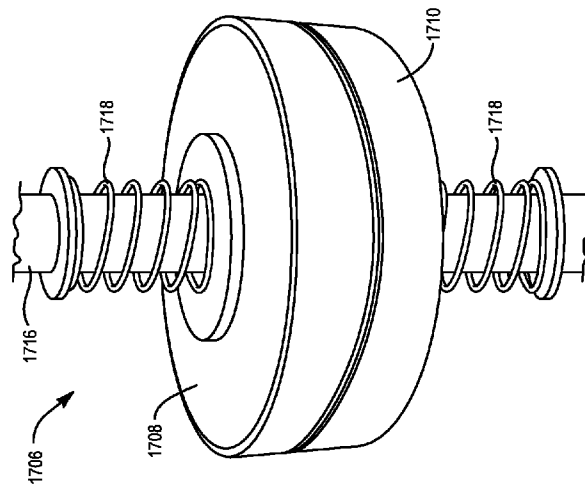

FIG. 71

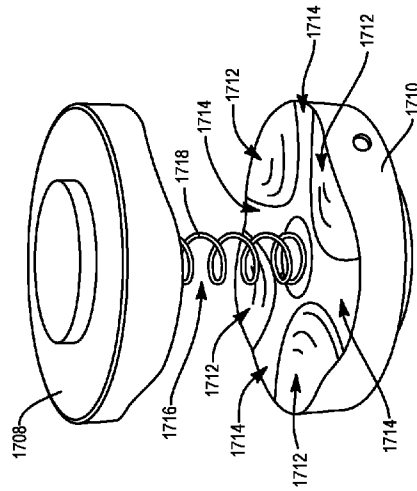

FIG. 73

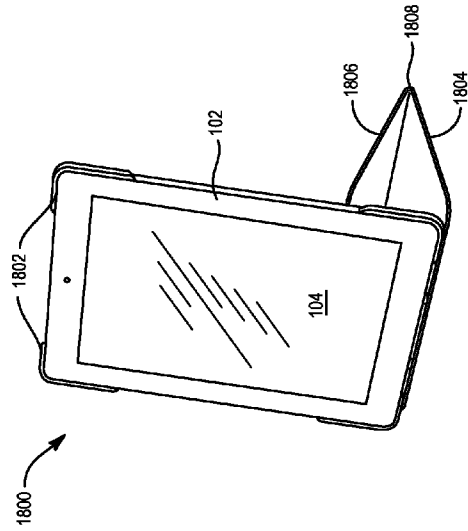

FIG. 75

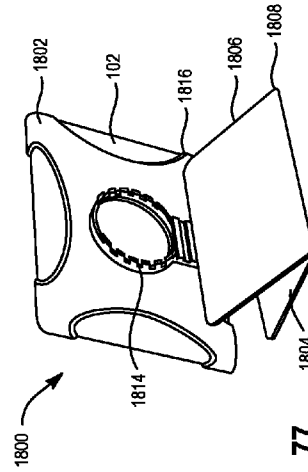

FIG. 77

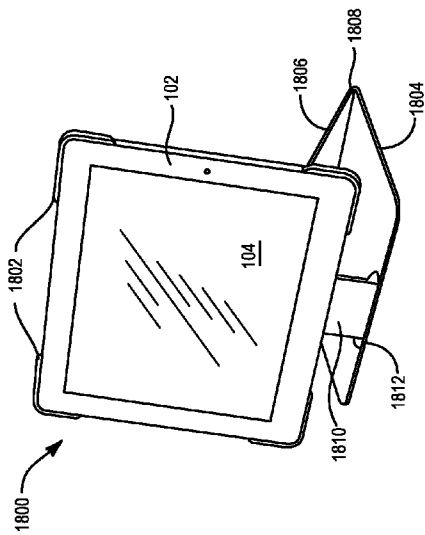

FIG. 74

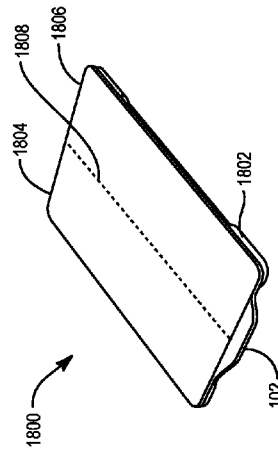

FIG. 76

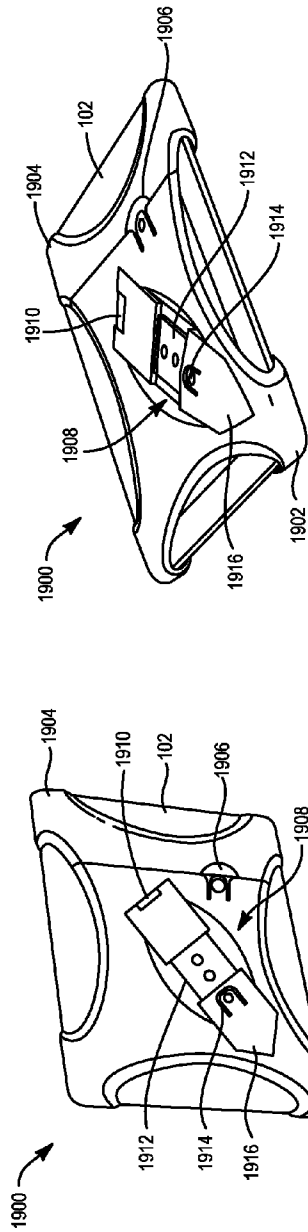

FIG. 79

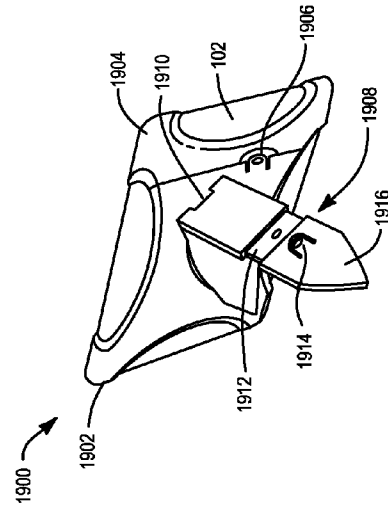

FIG. 81

FIG. 78

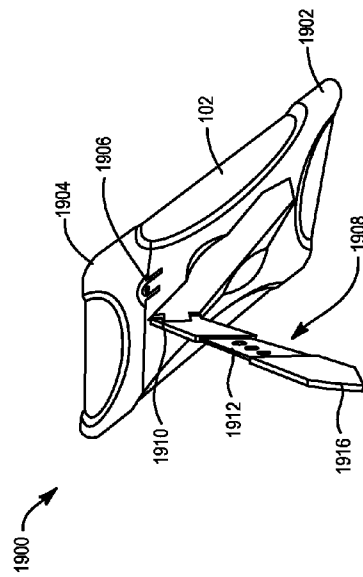

FIG. 80

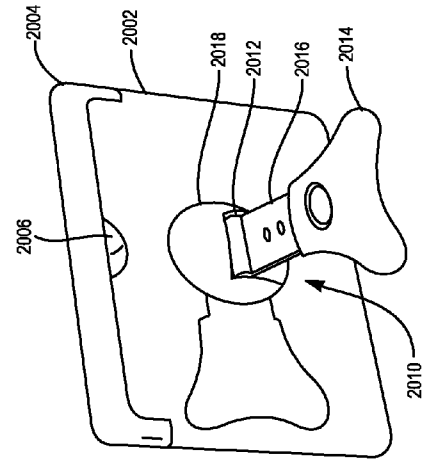

FIG. 83

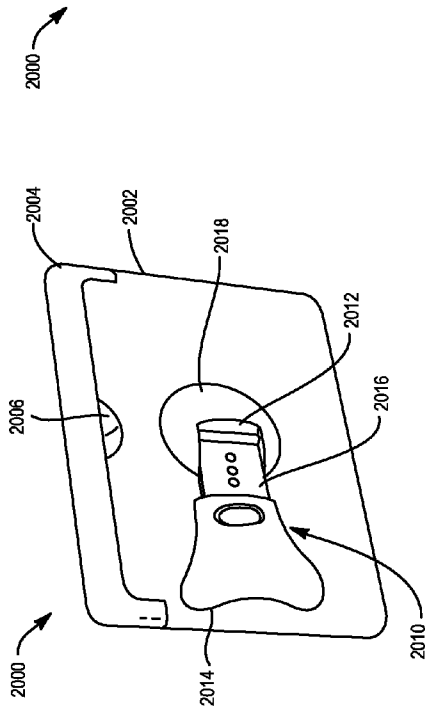

FIG. 82

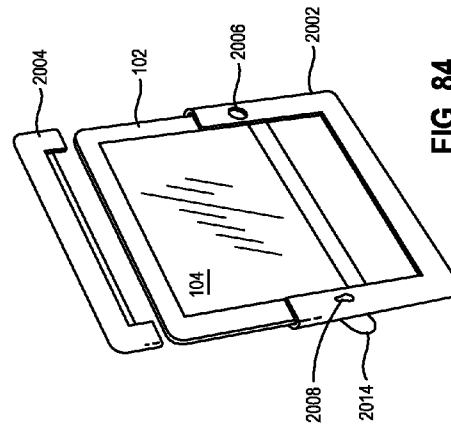

FIG. 84

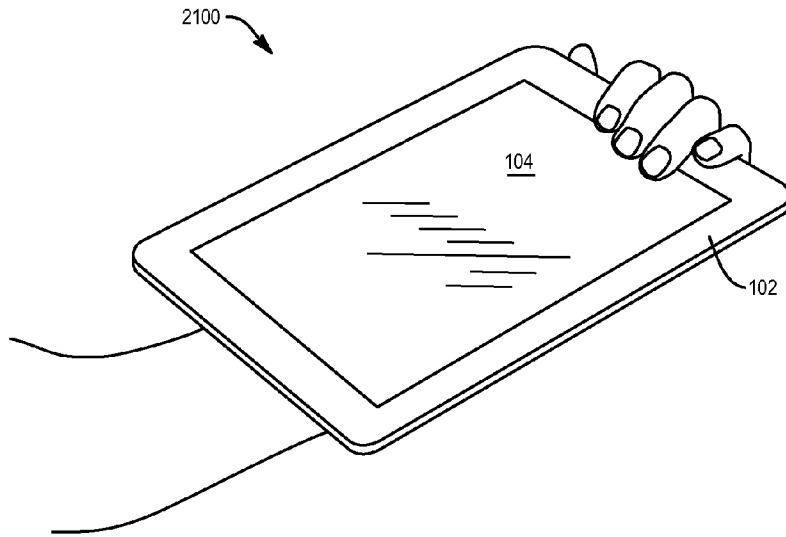

FIG. 85

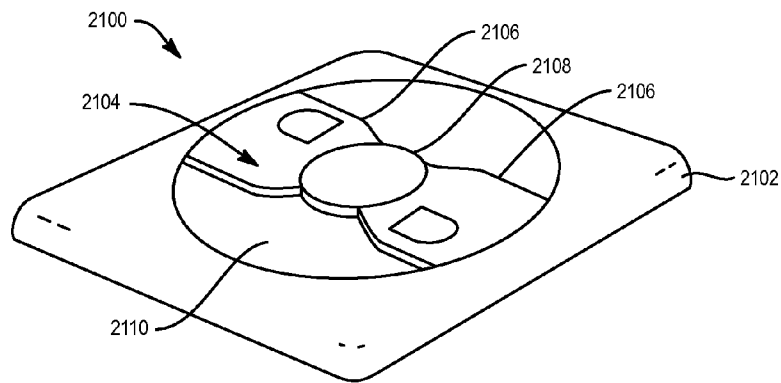

FIG. 86

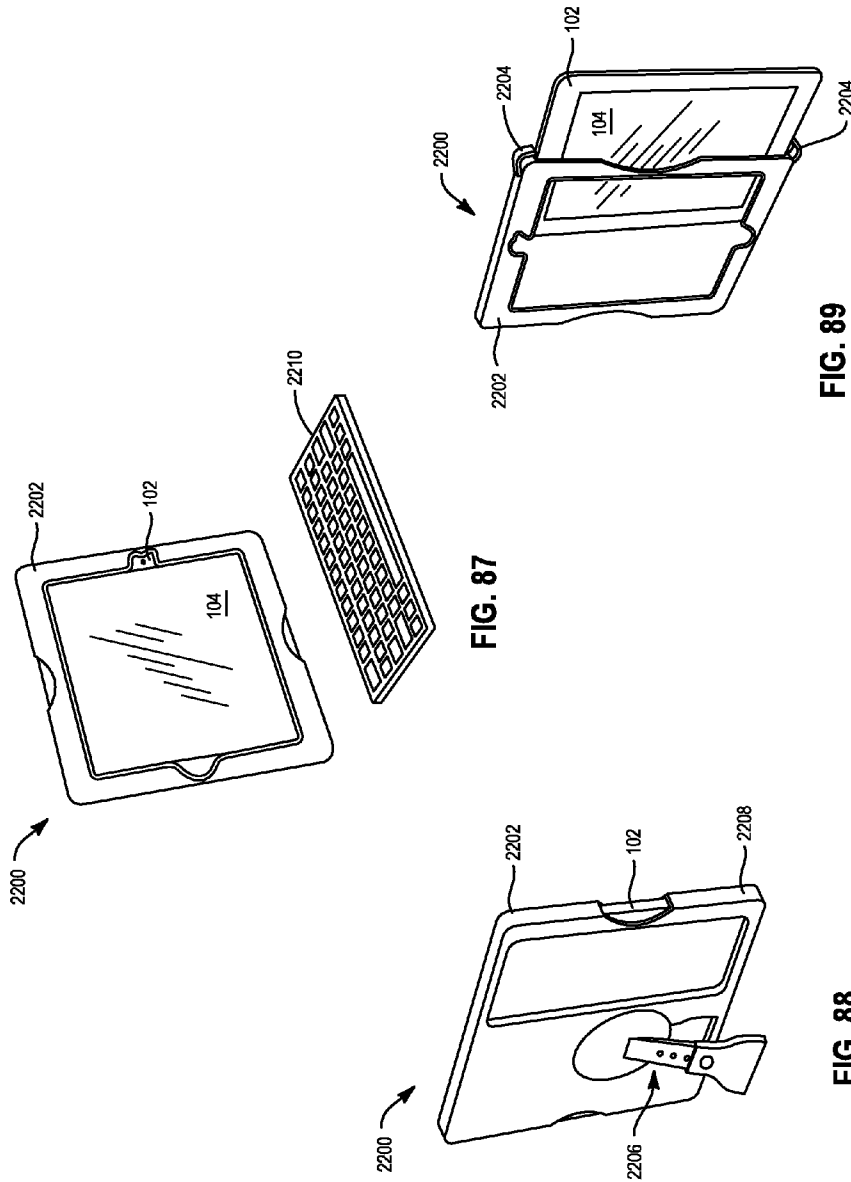

FIG. 87

FIG. 89

FIG. 88

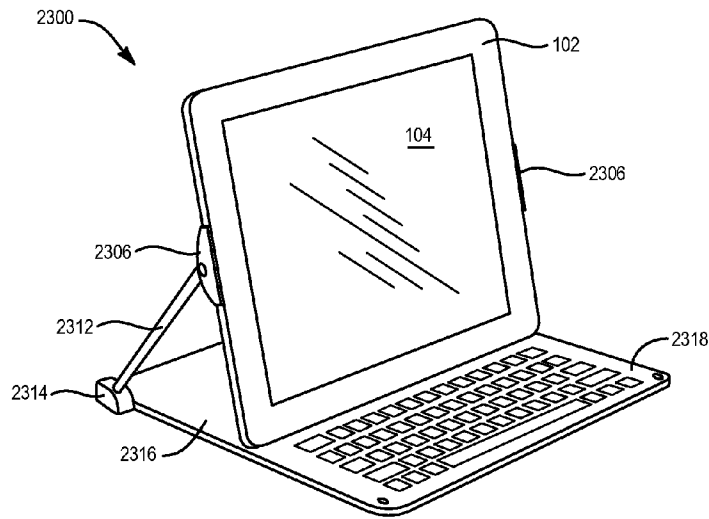

FIG. 90

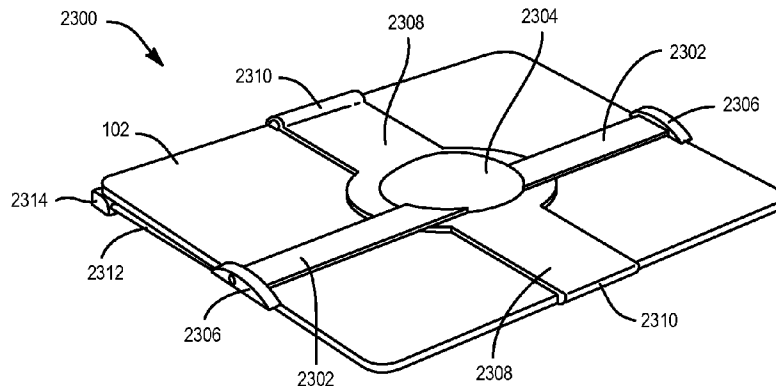

FIG. 91

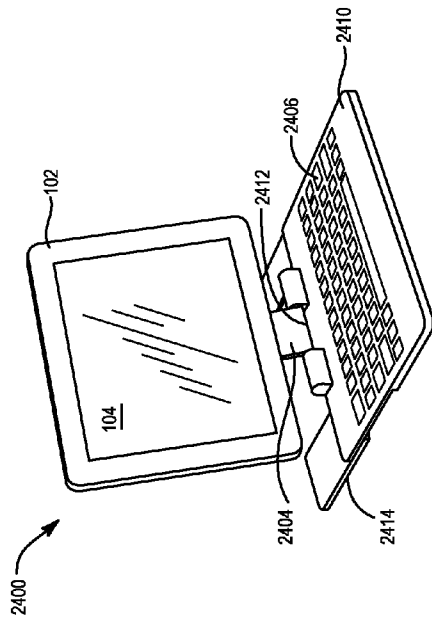

FIG. 93

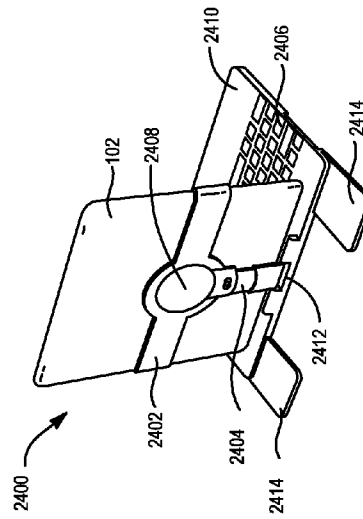

FIG. 95

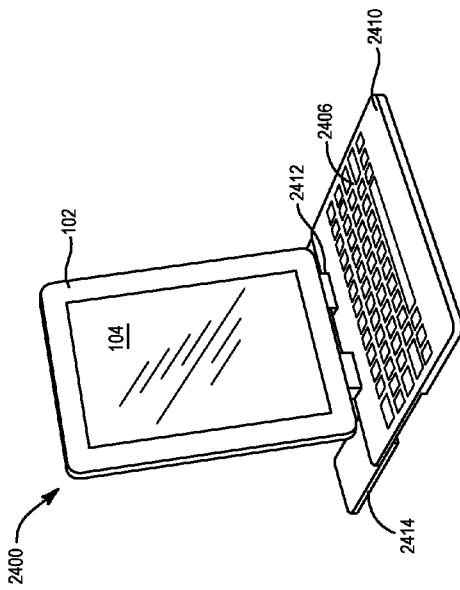

FIG. 92

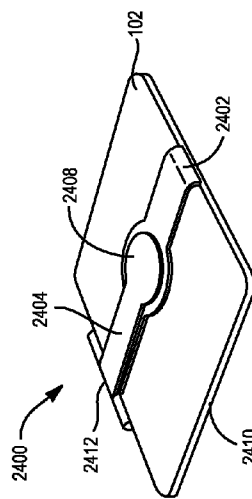

FIG. 94

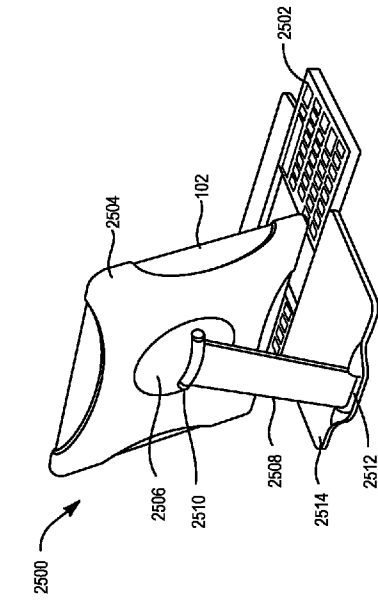

FIG. 97

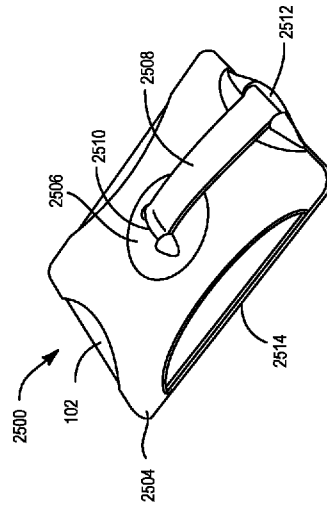

FIG. 99

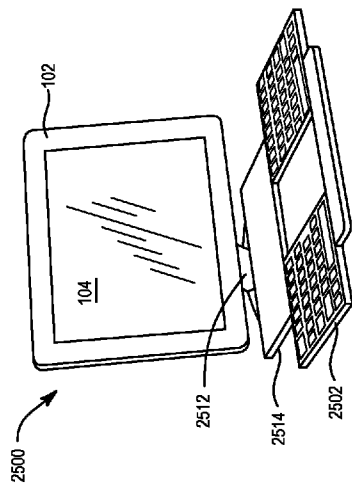

FIG. 96

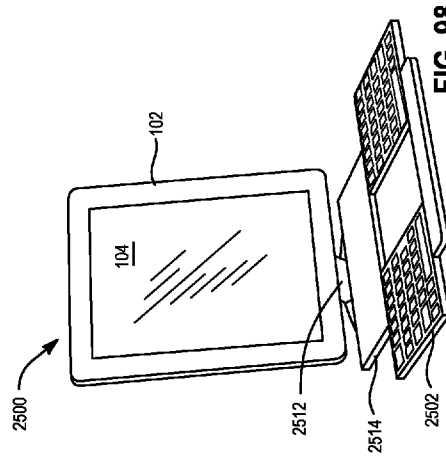

FIG. 98

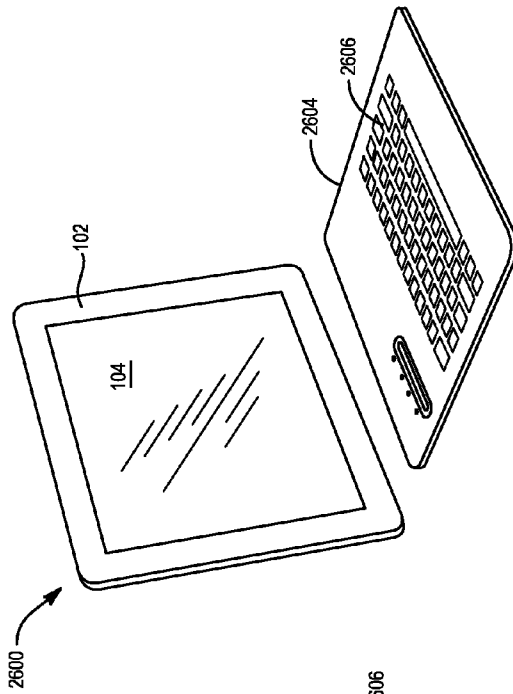

FIG. 100

FIG. 101

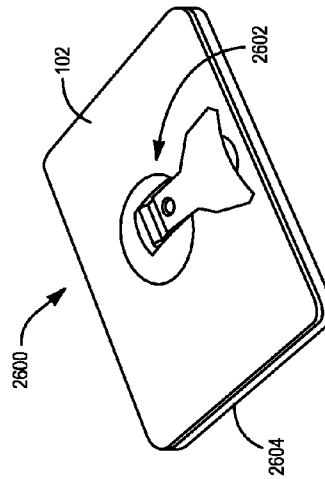

FIG. 102

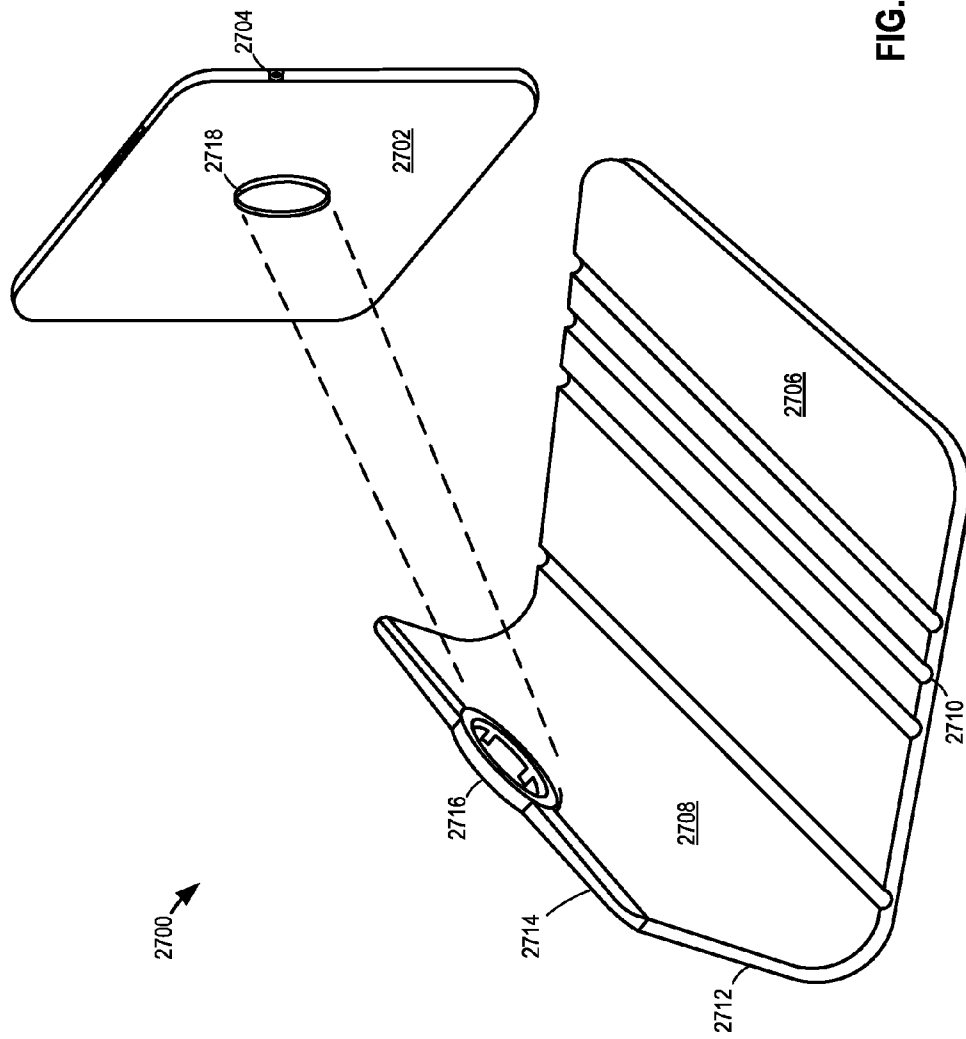

FIG. 103

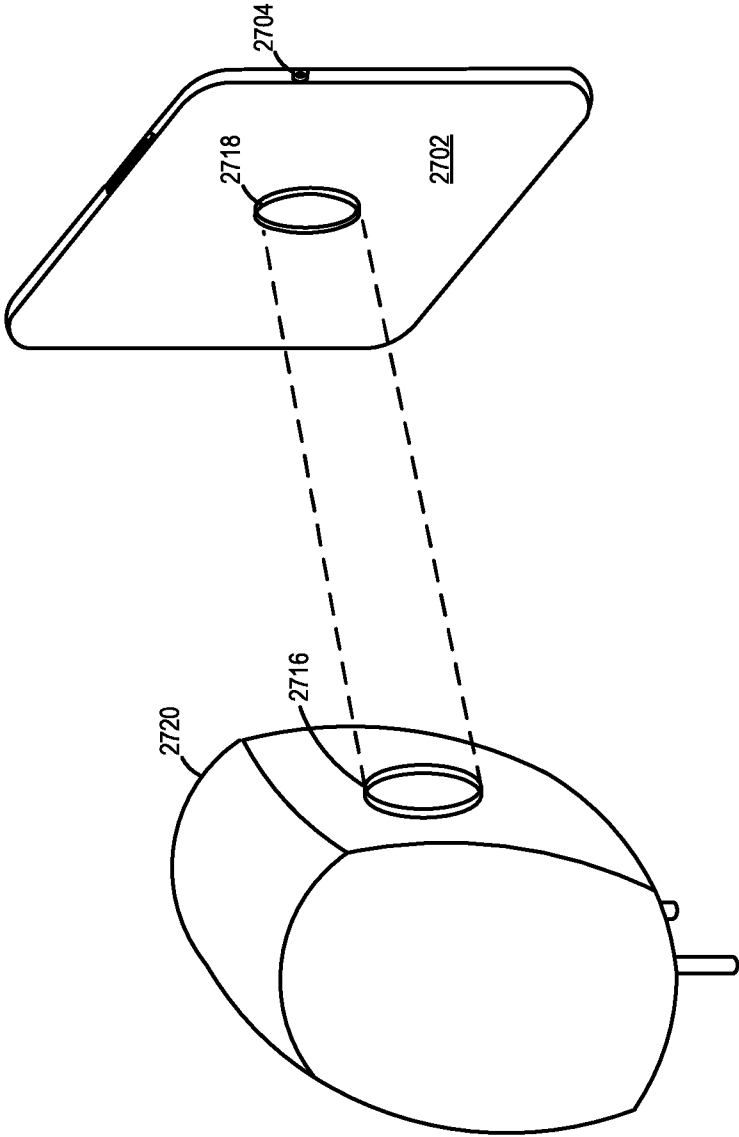

FIG. 104

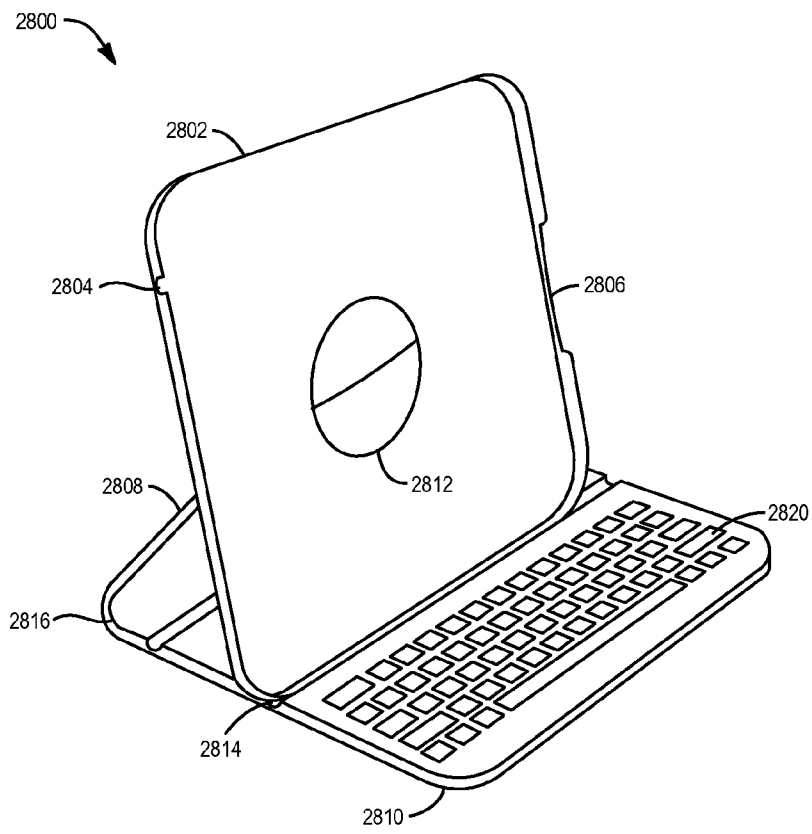

FIG. 105

**PORTABLE ELECTRONIC DEVICE CASE
ACCESSORIES AND RELATED SYSTEMS
AND METHODS**

RELATED APPLICATIONS

This application is a continuation of and claims priority to U.S. patent application Ser. No. 13/791,445, filed Mar. 8, 2013, and entitled "PORTABLE ELECTRONIC DEVICE CASE ACCESSORIES AND RELATED SYSTEMS AND METHODS," and which in turn is a continuation of and claims priority to U.S. patent application Ser. No. 13/155,266, filed Jun. 7, 2011, and entitled "PORTABLE ELECTRONIC DEVICE CASE ACCESSORIES AND RELATED SYSTEMS AND METHODS," and which in turn claims priority to U.S. Provisional Patent Application No. 61/352,286, filed Jun. 7, 2010, and entitled "ELECTRONIC READER CASES AND RELATED SYSTEMS AND METHODS," U.S. Provisional Patent Application No. 61/368,047, filed Jul. 27, 2010, and entitled "HOLDER FOR AN ELECTRONIC DEVICE," and U.S. Provisional Patent Application No. 61/421,431, filed Dec. 9, 2010, and entitled "ROTATABLE CASE FOR PORTABLE ELECTRONIC DEVICE," all of which are herein incorporated by reference in their entireties.

TECHNICAL FIELD

The present disclosure relates generally to portable electronic devices and, more specifically, to case accessories for portable electronic devices.

BRIEF DESCRIPTION OF THE DRAWINGS

The written disclosure herein describes illustrative embodiments that are non-limiting and non-exhaustive. Reference is made to certain of such illustrative embodiments that are depicted in the figures, in which:

FIG. 1 illustrates a case for a portable electronic device oriented in a portrait viewing mode consistent with embodiments of the present disclosure;

FIG. 2 illustrates a top perspective view of the case illustrated in FIG. 1 consistent with embodiments of the present disclosure;

FIG. 3 illustrates a rear elevation view of the case illustrated in FIG. 1 consistent with embodiments of the present disclosure;

FIG. 4 illustrates a rear elevation view of the case illustrated in FIG. 1 wherein the case is oriented in a landscape viewing mode consistent with embodiments of the present disclosure;

FIG. 5 illustrates another case for a portable electronic device configured in an open position and oriented in a portrait viewing mode consistent with embodiments of the present disclosure;

FIG. 6 illustrates a top perspective view of the case illustrated in FIG. 5 consistent with embodiments of the present disclosure;

FIG. 7 illustrates a rear elevation view of the case illustrated in FIG. 5 consistent with embodiments of the present disclosure;

FIG. 8 illustrates a rear elevation view of the case illustrated in FIG. 5 configured in an open position and oriented in a landscape viewing mode consistent with embodiments of the present disclosure;

FIG. 9 illustrates a top perspective view of the case illustrated in FIG. 5 configured in a closed position consistent with embodiments of the present disclosure;

FIG. 10 illustrates a side elevation view of the case illustrated in FIG. 5 configured in a closed position consistent with embodiments of the present disclosure;

FIG. 11 illustrates another case for a portable electronic device oriented in a portrait viewing mode consistent with embodiments of the present disclosure;

FIG. 12 illustrates a top perspective view of the case illustrated in FIG. 11 consistent with embodiments of the present disclosure;

FIG. 13 illustrates another case for a portable electronic device oriented in a portrait viewing mode consistent with embodiments of the present disclosure;

FIG. 14 illustrates a perspective view of the case illustrated in FIG. 13 consistent with embodiments of the present disclosure;

FIG. 15 illustrates another case for a portable electronic device configured in an open position consistent with embodiments of the present disclosure;

FIG. 16 illustrates an isometric view of a portion of the case illustrated in FIG. 15 consistent with embodiments of the present disclosure;

FIG. 17 illustrates a rotatable case for a portable electronic device configured in an open position consistent with embodiments of the present disclosure;

FIG. 18 illustrates another case for a portable electronic device configured in an open position and oriented in a portrait viewing mode consistent with embodiments of the present disclosure;

FIG. 19 illustrates a top perspective view of the case illustrated in FIG. 18 consistent with embodiments of the present disclosure;

FIG. 20 illustrates a rear elevation view of the case illustrated in FIG. 18 consistent with embodiments of the present disclosure;

FIG. 21 illustrates a rear elevation view of the case illustrated in FIG. 18 configured in an open position and oriented in a landscape viewing mode consistent with embodiments of the present disclosure;

FIG. 22 illustrates a rotatable case in a landscape orientation consistent with embodiments of the present disclosure;

FIG. 23 illustrates a rotatable case for a portable electronic device rotated into a portrait orientation consistent with embodiments of the present disclosure;

FIG. 24 illustrates a rotatable case in a closed position securing a portable electronic device consistent with embodiments of the present disclosure;

FIG. 25 illustrates a rotatable case securing a portable electronic device in a landscape orientation and a first opened position consistent with embodiments of the present disclosure;

FIG. 26 illustrates a rotatable case supporting a portable electronic device at an angle in a landscape orientation and in a second opened position consistent with embodiments of the present disclosure;

FIG. 27 illustrates a portable electronic device secured by a rotatable case including a pivot flap configured to allow the portable electronic device to be pivoted to a desired angle of inclination consistent with embodiments of the present disclosure;

FIG. 28 illustrates a portable electronic device secured by a rotatable case including a grommet configured to allow the portable electronic device to be rotated from a portrait orientation to a landscape orientation and vice versa consistent with embodiments of the present disclosure;

3

FIG. 29 illustrates a rear view of a rotatable case securing a portable electronic device in a portrait orientation consistent with embodiments of the present disclosure;

FIG. 30 illustrates an interaction between a support panel of a rotatable case and a securing panel via a grommet consistent with embodiments of the present disclosure;

FIG. 31 illustrates a securing panel of a rotatable case and a first portion of a grommet consistent with embodiments of the present disclosure;

FIG. 32 illustrates a support panel of a rotatable case including a pivot flap and a grommet consistent with embodiments of the present disclosure;

FIG. 33 illustrates a rotatable case integrated into a larger case consistent with embodiments of the present disclosure;

FIG. 34 illustrates a multi-pivot stand for a portable electronic device including a base, a vertical support, and a case configured in a landscape orientation consistent with embodiments of the present disclosure;

FIG. 35 illustrates a multi-pivot stand for a portable electronic device including a data dock consistent with embodiments of the present disclosure;

FIG. 36 illustrates a multi-pivot stand securing a portable electronic device in a landscape orientation consistent with embodiments of the present disclosure;

FIG. 37 illustrates a rear elevation view of a multi-pivot stand consistent with embodiments of the present disclosure;

FIG. 38 illustrates a side elevation view of a multi-pivot stand consistent with embodiments of the present disclosure;

FIG. 39 illustrates a multi-pivot stand including a case coupled to a vertical support consistent with embodiments of the present disclosure;

FIG. 40 illustrates a release lever configured to selectively release an upper connection member of a multi-pivot stand in order to rotate a case from a landscape orientation to a portrait orientation consistent with embodiments of the present disclosure;

FIG. 41 illustrates another view of the release lever illustrated in FIG. 40 consistent with embodiments of the present disclosure;

FIG. 42 illustrates another multi-pivot stand including a case configured to secure a portable electronic device capable of rotating from a landscape orientation to a portrait orientation consistent with embodiments of the present disclosure;

FIG. 43 illustrates a multi-pivot stand including a case configured to vertically pivot about an upper connection member consistent with embodiments of the present disclosure;

FIG. 44 illustrates another view of the multi-pivot stand illustrated in FIG. 43 consistent with embodiments of the present disclosure;

FIG. 45 illustrates a multi-pivot stand including a case configured to horizontally pivot about an upper connection member consistent with embodiments of the present disclosure;

FIG. 46 illustrates another view of the multi-pivot stand illustrated in FIG. 45 consistent with embodiments of the present disclosure;

FIG. 47 illustrates a component view of a multi-pivot stand including a base, a lower connection member, a vertical support, and upper connection member, and a case configured to secure a portable electronic device consistent with embodiments of the present disclosure;

FIG. 48 illustrates a base and a vertical support configured to be pivotably coupled via a lower connection member consistent with embodiments of the present disclosure;

4

FIG. 49 illustrates a base and a vertical support configured to be pivotably coupled via another lower connection member consistent with embodiments of the present disclosure;

FIG. 50 illustrates an exemplary base and vertical support configured to be pivotably coupled via a lower connection member consistent with embodiments of the present disclosure;

FIG. 51 illustrates a holder for a portable electronic device consistent with embodiments of the present disclosure;

FIG. 52 illustrates another view of the holder illustrated in FIG. 51 consistent with embodiments of the present disclosure;

FIG. 53 illustrates a holder for a portable electronic device in a handheld configuration consistent with embodiments of the present disclosure;

FIG. 54 illustrates another view of the holder illustrated in FIG. 53 consistent with embodiments of the present disclosure;

FIG. 55 illustrates a component view of the holder illustrated in FIG. 53 consistent with embodiments of the present disclosure;

FIG. 56 illustrates another view of the holder illustrated in FIG. 53 consistent with embodiments of the present disclosure;

FIG. 57 illustrates the holder illustrated in FIG. 54 in a stand configuration consistent with embodiments of the present disclosure;

FIG. 58 illustrates another view of the holder illustrated in FIG. 57 consistent with embodiments of the present disclosure;

FIG. 59 illustrates a rotatable holder for a portable electronic device in a handheld configuration consistent with embodiments of the present disclosure;

FIG. 60 illustrates another view of the rotatable holder illustrated in FIG. 59 consistent with embodiments of the present disclosure;

FIG. 61 illustrates a component view of the rotatable holder illustrated in FIG. 59 consistent with embodiments of the present disclosure;

FIG. 62 illustrates another view of the rotatable holder illustrated in FIG. 59 consistent with embodiments of the present disclosure;

FIG. 63 illustrates a handheld holder for a portable electronic device consistent with embodiments of the present disclosure;

FIG. 64 illustrates another view of the handheld holder illustrated in FIG. 63 consistent with embodiments of the present disclosure;

FIG. 65 illustrates another view of the handheld holder illustrated in FIG. 63 consistent with embodiments of the present disclosure;

FIG. 66 illustrates a handheld holder for a portable electronic device consistent with embodiments of the present disclosure;

FIG. 67 illustrates another view of the handheld holder illustrated in FIG. 66 consistent with embodiments of the present disclosure;

FIG. 68 illustrates a case for a portable electronic device consistent with embodiments of the present disclosure;

FIG. 69 illustrates another view of the case illustrated in FIG. 68 consistent with embodiments of the present disclosure;

FIG. 70 illustrates a handheld holder for a portable electronic device consistent with embodiments of the present disclosure;

FIG. 71 illustrates a rotatable coupling mechanism consistent with embodiments of the present disclosure;

5

FIG. 72 illustrates another view of the rotatable coupling mechanism illustrated in FIG. 71 consistent with embodiments of the present disclosure;

FIG. 73 illustrates another view of the rotatable coupling mechanism illustrated in FIG. 71 consistent with embodiments of the present disclosure;

FIG. 74 illustrates a rotatable case for a portable electronic device oriented in a landscape configuration consistent with embodiments of the present disclosure;

FIG. 75 illustrates the rotatable case illustrated in FIG. 74 oriented in a portrait configuration consistent with embodiments of the present disclosure;

FIG. 76 illustrates the rotatable case illustrated in FIG. 74 configured in a stowage mode consistent with embodiments of the present disclosure;

FIG. 77 illustrates a rear perspective view of the rotatable case illustrated in FIG. 74 oriented in a landscape consistent with embodiments of the present disclosure;

FIG. 78 illustrates a support for a portable electronic device consistent with embodiments of the present disclosure;

FIG. 79 illustrates the support illustrated in FIG. 78 consistent with embodiments of the present disclosure;

FIG. 80 illustrates the support illustrated in FIG. 78 configured in a portrait orientation consistent with embodiments of the present disclosure;

FIG. 81 illustrates the support illustrated in FIG. 78 configured in a landscape orientation consistent with embodiments of the present disclosure;

FIG. 82 illustrates a rotatable support for a portable electronic device consistent with embodiments of the present disclosure;

FIG. 83 illustrates the rotatable support illustrated in FIG. 82 configured in a landscape orientation consistent with embodiments of the present disclosure;

FIG. 84 illustrates another view of the rotatable support illustrated in FIG. 82 consistent with embodiments of the present disclosure;

FIG. 85 illustrates a handheld holder for a portable electronic device consistent with embodiments of the present disclosure;

FIG. 86 illustrates a rear perspective view of the handheld holder illustrated in FIG. 85 consistent with embodiments of the present disclosure;

FIG. 87 illustrates a support for a portable electronic device consistent with embodiments of the present disclosure;

FIG. 88 illustrates a rear perspective view of the support illustrated in FIG. 87 consistent with embodiments of the present disclosure;

FIG. 89 illustrates the support illustrated in FIG. 87 receiving a portable electronic device consistent with embodiments of the present disclosure;

FIG. 90 illustrates a rotatable case for a portable electronic device oriented in a landscape configuration consistent with embodiments of the present disclosure;

FIG. 91 illustrates the rotatable case illustrated in FIG. 90 configured in a stowage mode consistent with embodiments of the present disclosure;

FIG. 92 illustrates a rotatable case for a portable electronic device including an integrated keyboard oriented in a portrait configuration consistent with embodiments of the present disclosure;

FIG. 93 illustrates the rotatable case illustrated in FIG. 92 oriented in a landscape configuration consistent with embodiments of the present disclosure;

FIG. 94 illustrates the rotatable case illustrated in FIG. 92 configured in a stowage mode consistent with embodiments of the present disclosure;

6

FIG. 95 illustrates a rear perspective view of the rotatable case illustrated in FIG. 92 consistent with embodiments of the present disclosure;

FIG. 96 illustrates a rotatable case for a portable electronic device including an integrated keyboard oriented in a landscape configuration consistent with embodiments of the present disclosure;

FIG. 97 illustrates a rear perspective view of the rotatable case illustrated in FIG. 96 consistent with embodiments of the present disclosure;

FIG. 98 illustrates the rotatable case illustrated in FIG. 96 oriented in a portrait configuration consistent with embodiments of the present disclosure;

FIG. 99 illustrates the rotatable case illustrated in FIG. 96 configured in a stowage mode consistent with embodiments of the present disclosure;

FIG. 100 illustrates a support for a portable electronic device consistent with embodiments of the present disclosure;

FIG. 101 illustrates a front perspective view the support illustrated in FIG. 100 consistent with embodiments of the present disclosure;

FIG. 102 illustrates the support illustrated in FIG. 100 configured in a stowage mode consistent with embodiments of the present disclosure;

FIG. 103 illustrates an interaction between a support panel of a rotatable case for a portable electronic device and a securing panel via a selectively detachable rotational mechanism consistent with embodiments of the present disclosure;

FIG. 104 illustrates an interaction of a selectively detachable rotational mechanism and a securing panel of a rotatable case for a portable electronic device consistent with embodiments of the present disclosure; and

FIG. 105 illustrates a rotatable case including a user interface consistent with embodiments of the present disclosure.

DETAILED DESCRIPTION

The proliferation of portable electronic devices (PEDs), including notebook and tablet computers (e.g., the Apple® iPad™), portable digital assistants (PDAs), and smartphones, has placed more computing power into the hands of users than the computing power of early computers that occupied an entire room. This portable computing power has enhanced both personal and business mobile productivity. Due to their portability, however, PEDs may be susceptible to damage. In addition, PEDs may allow for viewing in a variety of orientations (e.g., portrait and/or landscape), but may not be configured to be easily used in multiple orientations.

Embodiments of the present disclosure provide an accessory case for a PED configured to protect the PED from damage. In some embodiments, the accessory case may be configured to enclose the PED and rotatably support the PED in at least two orientations. In various embodiments, the case may be configured to enclose and protect the PED in a closed position and support the PED upright and/or elevated (i.e., propped up) in an open position.

Embodiments may be best understood by reference to the drawings. In certain instances, like features may be designated with like reference numerals. It will be readily understood that the components of the present disclosure, as generally described and illustrated in the drawings herein, could be arranged and designed in a wide variety of different configurations. Thus, the following more detailed description of the embodiments of the apparatus is not intended to limit the scope of the disclosure, but is merely representative of pos-

sible embodiments of the disclosure. In some cases, well-known structures, materials, or operations are not shown or described in detail.

FIGS. 1-4 illustrate a case 100 for a PED 102 that can be used to assist in viewing the PED 102. The illustrated case 100 may be referred to as a holder, sleeve, mount, and the like and, as used herein, does not necessarily imply an encasing or retaining functionality, although some embodiments of the case 100 may have such functionalities. The PED 102 may be any portable electronic device including, for example, a notebook computer, an electronic book reader (e.g., the Amazon® Kindle™), a smartphone (e.g., the Apple® iPhone™, the Motorola® Droid®, and the BlackBerry® Storm™), and/or a tablet computer (e.g., the Apple® iPad™, the HP® Slate, and the Samsung® Galaxy™ Tablet).

The case 100 can be configured to receive a PED 102, and may further function to retain, carry, and protect the PED 102. The PED 102 can include on the front and/or the back face of the PED 102 a display 104 that is viewable in either a portrait orientation or a landscape orientation, a user input (not shown), and a data input/output port (not shown). In some embodiments, the case 100 may be configured such that the display 104, user input, and data input/output port are accessible by a user of the PED 102 while the PED 102 is disposed in the case 100. Further, in some embodiments, the case 100 may include a protective display disposed over the display 104.

The case 100 can assist a user in viewing the PED 102 when the display 104 is functioning in either the portrait or landscape orientation. This can be particularly advantageous, as users of a PED 102 may desire to alternate between using the PED 102 in the portrait and landscape orientations. Moreover, some users may prefer to use a PED 102 exclusively in either the portrait mode or the landscape mode. Since either group of users could use the case 100 effectively, the case 100 can advantageously serve to reduce sellers' inventories.

The case 100 may include a base 106, a support member 108, and a holder 110. The support member 108 and the holder 110 may be attached to each other at a rotatable connector 112. In the illustrated embodiment, the base 106 includes a platform 114 that can rest on a planar or substantially planar working surface, such as a floor or table top. The base 106 may define a series of channels 116 at a front end thereof. The support member 108 may include a post 118 that is fixedly secured to the platform 114. For example, the post 118 and the platform 114 may be integrally molded from a single piece of material (e.g., plastic), or they may be fixedly secured to each other in any other suitable manner. The illustrated post 118 thus may not be rotatable relative to the platform 114.

The rotatable connector 112 or rotational mechanism may be located at an upper end of the post 118. The connector may include a ball-and-socket joint 120, which permits rotation about three mutually perpendicular axes. Stated otherwise, the ball-and-socket joint 120 may permit the holder 110 to rotate about an axis defined by the post 118 (as indicated at the double-headed arrow 122), and also permit the holder 110 to rotate about two mutually orthogonal axes that are each perpendicular to the axis defined by the post 118 (as indicated at the double-headed arrows 122 and 124).

The holder 110 may be configured to grip or otherwise secure the PED 102. In certain embodiments, the holder 110 may include a sleeve 128, which may also be referred to as a pocket or a pouch, that is configured to retain therein the PED 102. For example, the sleeve 128 may comprise a resilient material that can selectively expand so as to receive the PED 102 through a front opening and resiliently close about an

outer edge of the PED 102. The holder 110 and/or sleeve 128 may also be configured to substantially cover the entirety of a back face of the PED 102. In some embodiments, the holder 110 and/or sleeve 128 may comprise a rubber or other elastomeric material (e.g., silicone) configured to provide a secure friction fit around the perimeter of the PED 102 to secure the holder 110 and/or sleeve 128 around the PED 102. The holder 110 and/or sleeve 128 may also comprise rigid materials (e.g., plastic, metal, and the like) and include a rigid frame. In some embodiments, the holder 110 and/or sleeve 128 may comprise releasable clips, straps, or other locking features that allow for the PED 102 to be selectively locked into the holder 110 and selectively released from the holder 110.

FIGS. 1-3 illustrate the case 100 in a portrait orientation which can assist a user in viewing a PED 102 when the display 104 is oriented in a landscape mode. The holder 110 can be rotated about one axis (shown by the arrow 124) so as to adjust a pitch of the PED 102. A bottom edge of the holder 110 thus can be situated in any of the channels 116. As shown in FIG. 2, the channels 116 may be substantially linear, such that rotation about another axis (shown by the arrow 126) may be restricted when the bottom edge of the holder 110 is situated within a channel 116.

As illustrated in FIGS. 3-4, the holder 110 can be rotated in another direction (shown by the arrow 122) so as to transition the case 100 from a portrait orientation to a landscape orientation. In the illustrated embodiment, the ball-and-socket joint 120 may be off-center relative to a width of the holder 110 and centered relative to a height of the holder 110 ("width" and "height" referring to the portrait orientation) such that a height of that portion of the holder 100 which is below the ball-and-socket joint 120 is the same or substantially similar when the holder 110 is in either of the portrait and landscape orientations. As a result, a bottom edge of the holder 110 can seat equally well in any of the channels 116 in either orientation. In such an arrangement, the holder 110 may be off-center relative to the base 106 when it is in the portrait orientation and centered relative to the base 106 in the landscape orientation.

In other embodiments, the ball-and-socket joint 120 may be centered relative to both the width and height of the holder 110. As the support member 108 may be fixed relative to the base 106, this may result in a different interaction between the bottom edge of the holder 110 and the channels 116 when the PED 102 is in the portrait and landscape orientations. For example, some channels 116 may be accessible in one orientation, but inaccessible in another. In some embodiments, the connector 112 can include a slide 130 or other suitable feature in addition to the ball-and-socket joint 120 so as to permit centering of the holder 110.

Other arrangements than those specifically described with respect to the embodiments illustrated in FIGS. 1-4 are contemplated. For example, in some embodiments, the base 106 may not include a platform 114 that is solid between its outer edges. In other or further embodiments, the support member 108 may be substantially wider than the post 118. In other or further embodiments, the holder 110 may not secure the PED 102 therein, but the PED 102 may rest on the holder 110. Moreover, for embodiments in which the PED 102 is secured to the holder 110, any suitable connectors, straps, holders, or other devices may be used to secure the PED 102 to the holder 110. In some embodiments, the holder 110 may include a clear protective sheet (e.g., a sheet of plastic) that covers a display 104 of the PED 110. The holder 110 may include an opening at a side or top edge thereof through which the PED 102 may be introduced into the holder 110. In still other or

further embodiments, the rotatable connector **112** may not include a ball-and-socket joint **120**, but instead may include another suitable connection system that permits rotation about at least two mutually orthogonal axes. In some embodiments, the ball-and-socket joint **120** may be self-tensioning, and in further embodiments, the channels **116** are not used. In 5 embodiments where the channels **116** are not used, the bottom edge of the holder **110** may be secured to the base **106** using alternative suitable connectors including, for example, straps, snaps, hook and loop fasteners, and the like.

FIGS. **5-10** illustrate another case **200** for a PED **102** that can be used to assist in viewing a PED **102**. In certain embodiments, case **200** may include similar features to case **100** illustrated in FIGS. **1-4**. Accordingly, like features may be designated in certain instances, but not all, with like reference numerals. Relevant disclosure set forth above regarding similarly identified features also may not be repeated hereafter. Moreover, specific features of the case **100** illustrated in FIGS. **1-4** may not be shown or identified by reference numerals in the drawings or specifically discussed in the written description that follows. However, such features may clearly be the same, or substantially the same, as features depicted in other embodiments and/or described with respect to such 15 embodiments. Accordingly, the relevant descriptions of such features apply equally to the features of the case **200**. Any suitable combination of the features and variations of the same described with respect to the case **100** can be employed with the case **200**, and vice versa. This pattern of disclosure applies equally to further embodiments depicted in subsequent figures and described hereafter.

As illustrated in FIG. **5**, the case **200** may include a base **202** that comprises a display cover **204** that in certain configurations, may function as a platform. The case **200** may further include a post **206** that is attached to the display cover **204** at a hinge **208**. The hinge **208** can provide the base **202** with one or more additional degrees of freedom in adjusting a viewing position of a holder **210**, as indicated by the double arrow **212**. This may also facilitate centering of the holder **210** in either a portrait or landscape orientation, as shown in FIG. **7** and FIG. **8**. Similar to the case **100**, the case **200** includes a rotational mechanism **220**, such as a ball-and-socket joint **220**, to provide rotational movement of the holder **210**. 35

In certain embodiments, the case **200** can transition between various open orientations, as shown in FIGS. **5-7** (i.e., open, portrait) and FIG. **8** (i.e., open, landscape), and a closed orientation, as shown in FIGS. **9-10**. In the illustrated embodiment, the case **200** is in the landscape orientation when it is closed. When the case **200** is closed, the holder **210** can encase a periphery and back face of the PED **102**, and the display cover **204** can cover a front face of the PED **102**, which include a display **104**. The post **206** may be bent to facilitate alignment of the holder **210** and the display cover **204**. 50

FIGS. **11-12** illustrate another case **300** for a PED **102** that can be used to assist in viewing the PED **102**. In certain embodiments, the case **300** can include a platform **302** that defines an opening **304**. In some embodiments, the opening **304** may be sufficiently large to receive a lower edge of a holder **306** therein in either a landscape or portrait orientation. The holder **306** can include a support wall **308** and one or more connectors **310**, such as resilient straps, that may be configured to hold the PED **102** against the support wall **308**. 55

FIGS. **13-14** illustrate another case **400** for a PED **102** that can be used to assist in viewing the PED **102**. In certain embodiments, the case **400** can include a platform **402** that defines two support legs **404** and a holder **408**. The holder **408** can include a support wall **410** and two or more rests **412**, **414**

that extend from the support wall **410**. The PED **102** can rest against the support wall **410** and rest **412** when the holder **408** is configured for portrait orientation viewing, and can rest against the support wall **410** and rest **414** when the holder **408** is configured for landscape orientation viewing. In some 5 embodiments, the PED **102** may not be physically secured to the holder **408**.

FIGS. **15-16** illustrate a case **500** configured to store items in addition to a PED **102**. The case **500** may include a holder **502** such as the holders described above. The holder **502** can comprise a back cover **504** and one or more connectors **506**, which can resemble the connectors described above. Other methods and devices for securing the PED **102** to the back cover **504** are also possible, including those discussed herein with respect to other embodiments. The back cover **504** can cover at least a portion of a rear face of the PED **102**. 15

In some embodiments, the back cover **504** may include a storage region **506**, which can be configured to store one or more accessories. For example, the storage region **506** can include one or more storage compartments **508**, which can receive one or more accessories therein. The accessories may be associated with the PED **102**, such as earphones (e.g., earbuds) **510**, a cleaning cloth **512**, cleaning solution **520**, cords (e.g., power cords), styluses, or the like. More or fewer compartments **508** than those shown in FIG. **15** may be used, and the compartments **508** may be of larger or smaller dimensions. Further, one or more accessories may be secured to the back cover **504** using other mechanical connection mechanisms including, for example, elastic straps. 20

As illustrated in FIGS. **15-16**, the compartments **508** can be box-shaped, and may function as bins. The compartments **508** may have hinged or removable covers for ready access to the contents thereof. The illustrated compartments **508** can define a depth that is about the same or slightly greater than a thickness of the PED **102**. Accordingly, in the illustrated embodiment, a front cover **514** can be oriented substantially parallel to the back cover **504** when the case **500** is closed. In other embodiments, one or more of the compartments **508** may be shaped as sleeves or pouches. The sleeves may be sealable, such as via snaps, buttons, hook and pile fastener, or the like. In still other embodiments, one or more of the compartments **508** may be shaped as loops or elongated sleeves, which may be particularly suitable for receiving writing implements (e.g., pens, pencils, styluses) therein. 35

The front cover **514** may be connected to the back cover **504** in any suitable manner, such as via one or more hinges **516**, **518**. In the illustrated embodiment, two hinges **516**, **518** are present. A first hinge **518** may be positioned adjacent to a base of the storage region **506**, and a second hinge **516** may be spaced from the first hinge **518** such that when the case **500** is closed, the second hinge **516** is positioned adjacent to an upper face of the storage region **506**. Such an arrangement can aid in aligning the front and back covers **514**, **504** in a parallel configuration. In other embodiments, a single hinge can instead be used, which may be positioned at the upper face of the storage region **506**. 45

Other arrangements than those specifically described with respect to the embodiments illustrated in FIGS. **15-16** are contemplated. For example, in some embodiments, the storage region **506** is positioned on the front cover **514**, or portions thereof are positioned on each of the front and back covers **514**, **504**. In some embodiments, the storage region **506** may be positioned at an outer side edge of one or more of the covers **504**, **514**, and in still other or further embodiments, the storage region **506** may be positioned along a top and/or bottom edge of one or more of the covers **504**, **514**. 60

FIG. 17 illustrates a rotatable case 600 for a PED 102 configured in an open position. In certain embodiments, the rotatable case 600 may include similar features to the case 500 illustrated in FIGS. 15-16 and/or any combination of the various features and embodiments described in any of the cases and/or holders described herein.

In certain embodiments, the rotatable case 600 may include a rotational mechanism 602 coupling the PED 102 to the holder 502, the back cover 504, and/or via another PED securement mechanism allowing for variable rotation of the PED 102 relative to the rotatable case 600. For example, as illustrated in FIG. 17, the rotational mechanism 602 may include a rotational grommet coupling the PED 102 to the holder 502, the back cover 504, and/or via another PED securement mechanism allowing for variable rotation of the PED 102 relative to the rotatable case 600. In other embodiments, the rotational mechanism 602 may include a ratcheting swivel or pivot, a ball and socket mechanism, a temporary adhesive, a releasable latch, a clip, one or more buttons, a suction cup, and/or one or more straps allowing for rotational securement. In certain embodiments, the rotational mechanism 602 may snap into certain specific rotational orientations (e.g., portrait orientation and/or landscape orientation) and require rotational force to move to a different specific orientation. In alternative embodiments, the rotation mechanism 602 may not snap into specific orientations but may allow for rotational articulation in any number of orientations.

FIGS. 18-21 illustrate another case 700 for a PED 102 that can be used to assist in viewing a PED 102. In certain embodiments, case 700 may include similar features to case 100 illustrated in FIGS. 1-4, case 200 illustrated in FIGS. 5-10, and/or any combination of the various features and embodiments described in any of the cases and/or holders described herein.

As illustrated in FIG. 18, the case 700 may include a base 702 that comprises a display cover 704 that in certain configurations, may function as a platform. The case 700 may further include a post 706 that is attached to the display cover 704 at a hinge 708. The hinge 708 can provide the base 702 with one or more additional degrees of freedom in adjusting a viewing position of a holder 710. This may also facilitate centering of the holder 710 in either a portrait or landscape orientation, as shown respectively in FIG. 20 and FIG. 21.

In certain embodiments, the case 700 may include a rotational grommet 712 coupling the PED 102 and/or the holder 710 to the post 706 allowing for variable rotation of the PED 102 and/or the holder 710 relative to the post 706 in one or more directions. In certain embodiments, the rotational grommet 712 may snap into certain specific rotational orientations (e.g., portrait orientation and/or landscape orientation) and require rotational force to move to a different specific orientation. In alternative embodiments, the rotational grommet 712 may not snap into specific orientations but may allow for rotational articulation in any number of orientations.

FIG. 22 illustrates a rotatable case 800 in a landscape orientation. As illustrated, the rotatable case 800 includes a securing panel 802 configured to secure a PED (not shown). According to various embodiments, the rotatable case 800 may include various access ports (such as 804 and 806) to facilitate interfacing a PED disposed within the case 800 with connector plugs, cables, headphones, speakers, and/or power adaptors. In certain embodiments, the rotatable case 800 may include built-in cords to route power, connectivity, and/or headphone cables from a PED to an external device. Moreover, according to various embodiments, a battery may be built into a panel or pocket of rotatable case 800.

In certain embodiments, the rotatable case 800 may have the ability to rotate securing panel 802 with respect to a supporting panel 808 and a base panel 810. Any of a wide variety of rotatable securing devices may be employed to rotatably secure securing panel 802 to supporting panel 808. For example, bushings, flanged bushings, grommets, rivets, eyelets, plain bearings, bearings, and/or any combination thereof may be employed to rotatably secure securing panel 802 to supporting panel 808. For example, as illustrated, a grommet 812 may be configured to rotatably secure the securing panel 802 to the supporting panel 808. In some embodiments, the grommet 812 may comprise a ring that may allow a logo to show through the hole in the middle of grommet 812. In certain embodiments, one or more interchangeable accessories and/or inserts may “snap” into the hole in the middle of grommet 812 including, for example, a logo insert, a proximity alarm or other loss prevention accessory, and the like. Alternatively, the hold in the middle of grommet 812 may define an opening and/or aperture that may allow viewing of the interior of the rotatable case 800 and/or a portion of a PED (not shown) disposed therein (e.g., a portion of the PED including a logo).

The base panel 812 may be configured with channels or groves 814 to secure the bottom edge of securing panel 802 when the securing panel 802 is in an upright and/or elevated position. According to various alternative embodiments, in place of channels 814 a frictional surface (e.g., rubberized surface or the like) or frictional contact patches may be utilized to secure the bottom edge of the securing panel 802 in an upright and/or elevated position.

The supporting panel 808 may be configured to provide a counterforce to the securing panel 802 in order to support securing panel 802 in an upright and/or elevated position. As illustrated, the supporting panel 808 and the base panel 810 may comprise a single panel folded or bent at 816. According to various embodiments, the relative proportions of the base panel 810 and the supporting panel 808 may be adapted for a particular application. Further, in certain embodiments, the rotatable case 800 may be configured to support a PED at one or more angles relative to the base panel 810 and in a plurality of orientations, including portrait and landscape.

FIG. 23 illustrates a rotatable case 800 for a PED 102 rotated into a portrait orientation. Similar to the embodiments illustrated in FIG. 1, the base panel 810 may include one or more channels 814 configured to secure the bottom edge of a PED 102 and/or the bottom edge of a securing panel 802. The rotatable case may further include a supporting panel 808 configured to fold at 816 with respect to the base panel 810.

A comparison of FIG. 22 and FIG. 23 illustrates the ability to rotate the securing panel 802 with respect to supporting panel 808 consistent with embodiments disclosed herein. According to various embodiments, the grommet 812 may allow a PED 102 to be rotated from a landscape orientation, as illustrated in FIG. 22, to the portrait orientation illustrated in FIG. 23.

In certain embodiments, the securing panel 802, base panel 810, and/or supporting panel 808 may provide protection to an enclosed PED 102. For example, the securing panel 802, base panel 810, and/or supporting panel 808 may be configured to protect the PED 102 from scratches, from damage as a result of a fall, from extreme temperatures, and/or other conditions that may result in damage to the PED 102. Accordingly, any portion of the rotating case 800 may be reinforced with padding, metal, plastic, cardboard, rubber, and/or other material or combination thereof.

In certain embodiments, the reinforcing material may utilize various folds, bends, and/or curvatures to obtain desirable

13

resistance and/or resilience characteristics. For example, fold **816** may be configured to function as a bi-stable, tri-stable, or N-stable fold, allowing a user to selectively fold the support panel **808** with respect to the base panel **810** into one or more predetermined angles. In some embodiments, by providing an N-stable fold **816**, the support panel **808** may effectively “snap” into one or more predetermined positions in order to support the PED **102** at predetermined angles with respect to the base panel **810**.

FIG. **24** illustrates a rotatable case **800** in a closed position securing a PED **102** therein. As illustrated, the securing panel **802** may include one or more access ports **804**. A grommet **812** may serve to rotatably secure the support panel **808** to securing panel **802**. In certain embodiments, the grommet **812** may include a see-through center circle making a portion of the PED **102** visible even when rotatable case **802** is in a closed position. In some embodiments, a transparent material may cover the center of the circle made by grommet **812**. According to other embodiments, the center circle of grommet **812** may be filled with any type of material, including the same type of material used for the support panel **808** and/or the securing panel **802**.

The support panel **808** may comprise a lower portion **818** and a pivot flap **820**. The pivot flap **820** may be configured to fold or pivot with respect to the lower portion **818** of the support panel **808**. As illustrated, the grommet **812** may be secured to the pivot flap **820**, allowing the grommet **812** and the securing panel **802** to pivot with respect to the lower portion **818** of the supporting panel **808**.

Any of a variety of fasteners (not shown) may be employed to selectively maintain the rotatable case **800** in the closed position. For example, a fastener may be configured to selectively maintain the securing panel **802** parallel to base panel **810**. The fastener may comprise any of a variety of fasteners commonly employed in cases, bags, and luggage. Examples of possible closure mechanisms include, but are not limited to, straps, buttons, flaps, snaps, Velcro, hooks, clasps, clips, and combinations thereof. In certain embodiments, the ends of an elastic strap may be secured to the base panel **810** and the strap may be selectively wrapped around the securing panel **802**. Accordingly, the securing panel **802** may be elastically maintained in a closed position. Additionally, though not illustrated, the rotatable case **800** may include any of a wide variety of straps, handles, harnesses, and/or the like configured to enable a user to easily transport the rotatable case **800**.

FIG. **25** illustrates a rotatable case **800** securing a PED **102** in a landscape orientation and a first opened position. As illustrated, the support panel **808** may be folded at **816** with respect to the base panel **810**. The grommet **812** may be configured to rotatably secure the securing panel **802** with respect to the support panel **808**. In certain embodiments, the grommet **812** may rotatably secure a pivot flap **820** of the support panel **808** to the securing panel **802**, thereby allowing the securing panel **802** to be pivoted with respect to a lower portion **818** of the support panel **808**. In some embodiments, the grommet **812** may allow a portion of the PED **102** to be seen through the center ring. For example, a logo included on the PED **102** may be visible.

As previously described, the base panel **810** may include one or more channels **814** configured to prevent a bottom edge of the securing panel **802** from slipping when in an upright and/or elevated supported position. Alternative features may be utilized in place of the one or more channels **814** including, for example, frictional contact patches, catches, magnets, protrusions, and/or other features configured to prevent a bottom edge of the securing panel **802** from slipping. In

14

certain embodiments, the securing panel **802** may include one or more access ports, such as a headphone access port **804**.

FIG. **26** illustrates a rotatable case **800** supporting a PED (not shown) at an angle in a landscape orientation and in a second opened position. Particularly, FIG. **26** illustrates the functionality of the pivot flap **820** (not visible) included in rotatable case **800**. As previously described, by folding a pivot flap **820** with respect to lower portion **818** of the support panel **808**, the securing panel **802** may be pivoted with respect to the supporting panel **808**. In the illustrated position, the support panel **808** supports the securing panel **802** at an angle with respect to the base panel **810**. A first channel of channels **814** prevents a bottom edge of the securing panel **802** from slipping along the base panel **810**. In certain embodiments, additional folding of the pivot flap **820** and/or the support panel **808** at **816** may allow the PED **102** to be supported at various angles of inclination by placing the bottom edge of the securing panel **802** in a different channel of channels **814**. In certain embodiments, the securing panel **802** may include one or more access ports, such as a headphone access port **804**.

FIG. **27** illustrates a PED **102** secured by a rotatable case **800** including a pivot flap **820** (not visible) configured to allow the PED **102** to be pivoted to a desired angle of inclination. The pivot flap **820** (not visible) may allow the PED **102** to be secured within the securing panel **802** to pivot with respect to the support panel **808**. As illustrated, the PED **102** may be pivoted into a desired angle of inclination. In certain embodiments, the PED **102** may be pivoted from the closed position illustrated in FIG. **24**, in which the PED **102** is parallel to base panel **810**, to any angle of inclination between with respect to the base panel **810**. Accordingly, the PED **102** may be pivoted until the securing panel **802** is again parallel with the base panel **810** and with the display **104** of the PED **102** facing up.

In certain embodiments, the PED **102** secured by the securing panel **802** may be pivoted to a desired angle of inclination. The support panel **808** may provide sufficient support to maintain the PED **102** at the desired angle of inclination. One or more channels **814** may prevent a bottom edge of the securing panel **810** from slipping along the base panel **810**.

FIG. **28** illustrates a PED **102** secured by a rotatable case **800** including a grommet **812** (not visible) configured to allow the PED **102** to be rotated from a portrait orientation to a landscape orientation and vice versa. As illustrated, a rotatable grommet **812** (not visible) may be configured to allow a PED **102** disposed in a securing panel **802** to be rotated from a portrait orientation to a landscape orientation and vice versa. In certain embodiments, the PED **102** may be configured to rotate from a first landscape position, as illustrated in FIG. **22** to a second portrait position, as illustrated in FIG. **23**. In certain embodiments, the PED **102** may be rotated 360 degrees into any desired orientation.

In some embodiments, the PED **102** may be configured to rotate only into specific orientations. For example, at 0 degrees the PED **102** may be in a first landscape orientation; the PED **102** may be rotated 90 degrees to a first portrait orientation, rotated an additional 90 degrees to a second landscape orientation, and rotated a final 90 degrees to a second portrait position. In the second portrait position it may reach a stop and may be rotated in the opposite direction to return the PED **102** to prior orientations. In certain embodiments, the rotational mechanism (e.g., grommet **812**) of the case **800** may snap into certain specific orientations and require rotational force to move to a different specific orientation.

FIG. **29** illustrates a rear view of a rotatable case **800** securing a PED **102** in a portrait orientation. As illustrated, a pivot flap **820** may be folded with respect to a lower portion

15

818 of the support panel **808**. Accordingly, a PED **102** secured by the securing panel **802** may be supported at one or more specific angles with respect to the support panel **808** and the base panel **810** (not visible). A grommet **812** or other rotational mechanism may rotatably secure the securing panel **802** to the pivot flap **820**. As previously described, the grommet **812** may allow the PED **102** and the securing panel **802** to be rotated with respect to the support panel **808**, including, for example, in a portrait and/or landscape orientation.

FIG. 30 illustrates an interaction between a support panel **808** of a rotatable case **800** and a securing panel **802** via a grommet **812**. In certain embodiments, the grommet **812** may comprise a rear portion **812** and a front portion **822**. The rotatable case **800** may include a base panel **810** with one or more channels **814**, a supporting panel **808** comprising a lower portion **818**, and a pivot flap **820**, and a rear portion **812** of the grommet. A securing panel **802**, including one or more access ports **804**, may be mounted to a front portion **822** of the grommet. According to various embodiments, the front portion **822** of the grommet may be mated with the rear portion **812** of the grommet in order to rotatably secure the securing panel **802** to the pivot flap **820**. In this manner, the securing panel **802** may be free to rotate 360 degrees relative to the support panel **808**.

In certain embodiments, the front portion **822** of the grommet and the rear portion **812** of the grommet may be joined together during manufacturing or assembly and are not configured to be selectively separated by a user. Alternatively, a user may selectively separate the front portion **822** of the grommet from the rear portion **812** in order to remove the securing panel **802** from the pivot flap **820**. In other embodiments, the front portion **822** and the rear portion **812** of the grommet are inseparable and the grommet may be selectively detachable from the pivot flap **820** and/or the securing panel **102**.

FIG. 31 illustrates a securing panel **802** of a rotatable case **800** and a front portion of a grommet **822**. The securing panel **802** may include sidewalls to protect and/or secure the edges of a PED **102** (not shown). According to various embodiments, a PED **102** may effectively snap into place within the securing panel **802**. Alternatively, a PED **102** may be secured within the securing panel **802** utilizing one or more straps, buckles, clips, adhesives, and/or similar features. The securing panel **802** may further utilize neoprene or rubber to selectively secure the PED **102**. Additionally, the sidewalls, or a portion thereof, of the securing panel **802** may wrap around the front of a secured PED **102**. In certain embodiments, the securing panel **802** may comprise a holder similar to the holders described herein.

The securing panel **802** may further include one or more access ports **804**, **806**, **824**. For example, a headphone access port **804**, a volume rocker access port **806**, and/or a power or connection access port **824** may be available. As previously described, a grommet portion **822** may be configured to rotatably secure the securing panel **802** to a pivot flap **820** of a support panel **808**. The securing panel **802** may comprise various materials such as plastic, rubber, metal, leather, faux leather, vinyl, nylon, and/or any of a wide variety of alternative decorative or useful materials utilized in cases, bags, luggage, and the like.

FIG. 32 illustrates a support panel **808** of a rotatable case **800** including a pivot flap **820** and a grommet **812**. As illustrated, the pivot flap **820** may include a grommet **812** and be configured to fold with respect to a lower portion **818** of the support panel **808**. Accordingly, the pivot flap **820** and grommet **812** may pivot with respect to the lower portion **818** of the support panel **808** to a desired angle of inclination. According

16

to various embodiments, the pivot flap **820** may be configured to resiliently return to its original, unfolded, position when the pivoting force is removed. Alternatively, the pivot flap **820** may be configured to pivot with respect to a lower portion **818** of the support panel **808** and thereafter maintain the pivoted position until forced to a new angle of inclination.

The pivot flap **820** may be connected to a lower portion **818** of the support panel **808** utilizing any of a variety of known pivotable connectors. In some embodiments, the support panel **808**, including both the lower portion **818** and the pivot flap **820** may be manufactured using a material or fabric, such as leather, faux leather, and/or vinyl. In such embodiments, the pivotable connection between the pivot flap **820** and the lower portion **818** of the support panel **808** may be a sewn section of a similar or identical material.

FIG. 33 illustrates a rotatable case **800** integrated into a larger case **826**. As illustrated, the rotatable case **800** may be integrated as an additional side pocket on a larger case **826**. According to various embodiments, the rotatable case **800** may alternatively be integrated within an internal compartment of larger case **826**. Additionally, in certain embodiments, a base panel **810** may be a shared panel or wall of the larger case **826**; and thus only include the remaining portions of the rotatable case **800**. That is, a wall of larger case **826** may share a common wall with the base panel **810** of rotatable case **800**.

In certain embodiments, the rotatable case **800** may include any combination of the various features and embodiments described in any of the cases described herein. Moreover, the larger case **826** may be configured with a handle **830** and a zipper **828**. The larger case **826** may be any of a wide variety of cases, including a brief case, luggage, a laptop case, a case for a PED **102**, and the like.

FIG. 34 illustrates a multi-pivot stand **900** for a PED (not shown) including a base **902**, a vertical support **904**, and a case **906** configured in a landscape orientation. In certain embodiments, the base **902** may be constructed of any shape and/or size suitable to adequately support a PED secured within the case **906**. In some embodiments, the base **902** may be weighted, include adjustable feet, have a no-slip bottom and/or top surface, and/or include a logo disposed thereon.

A vertical support **904** may be coupled to the base **902** via a lower connection member **908**. In certain embodiments, the lower connection member **908** may comprise a swivel joint configured to allow the vertical support **904** to be rotated and pivoted in a variety of angles and directions with respect to the base **902**. In some embodiments, the lower connection member **908** may comprise a swivel joint configured to allow the vertical support **904** to be rotated but not pivoted, pivoted but not rotated, or rotated and pivoted. The lower connection member may further comprise any variety of known rotatable and/or pivotable connections, including ball joints, ball and socket connections, bearings, pivot rods, slip rings, swivel joints, swing joints, and the like.

In certain embodiments, the lower connection member **908** may comprise a fixed connection member securing a vertical support **904** relative to the base **902**. The vertical support **904** and the base **902** may also be manufactured as a single piece, thereby limiting relative movement between the vertical support **904** and the base **902**.

The case **906** may be configured to securing a PED (not shown). In certain embodiments, the case **906** may comprise components and designs similar to the other cases and holders disclosed herein. The design of the case **906**, including its dimensions and positions of any access ports **910-914** may be adapted for a specific PED. In some embodiments, a PED may be configured to snap into the case **906** or be secured

17

therein using one or more corner securement members (e.g., resilient straps). In certain embodiments, the case 906 may include flexible sidewalls configured to secure a PED. In some embodiments, the flexible sidewalls may be configured to secure a PED by wrapping around the sides and/or a portion of the front of a PED.

As is described in more detail below, the case 906 may be coupled to the vertical support 904 via an upper connection member (not visible) configured to allow the case 906 to be rotated and/or pivoted with respect to the vertical support 904. In certain embodiments, the stand 900 may include a lever 916 configured to selectively lock and release the lower connection member 908 and or the upper connection member. The stand 900 may further include a plurality of levers configured, for example, to control one or more of the connection members separately.

FIG. 35 illustrates a multi-pivot stand 900 for a PED (not shown) including a data dock 918. In certain embodiments, the data dock 918 may be configured to provide power and/or a data connection to a PED secured by a case 906. In various embodiments, the data dock 918 may be communicatively coupled to an external connector 920 such as, for example, a USB connector and/or power connector, via a cable 922. In some embodiments, the type, shape, size and number of data docks 918 may be adapted for a specific PED. In certain embodiments, the data dock 918 and the external connector 920 may be interchangeable with each other and/or other various alternative connectors.

FIG. 36 illustrates a multi-pivot stand 900 securing a PED 102 in a landscape orientation. As illustrated, the case portion 906 of the stand 900 may be configured to secure the PED 102 therein. In some embodiments, the PED 102 may be configured to snap into the case 906 using one or more corner securement members (e.g., resilient straps). In certain embodiments, the case 906 may include flexible sidewalls configured to secure the PED 906. In some embodiments, the flexible sidewalls may be configured to secure the PED 906 by wrapping around the sides and/or a portion of the front of a PED 906 while still allowing a user to view the display 104.

FIG. 37 illustrates a rear elevation view of a multi-pivot stand 900. As illustrated, the stand 900 may include a case 906 coupled to a vertical support 904 via an upper connection member 926. Additionally, the vertical support 904 may be coupled to a base 902 via a lower connection member 908 such that the vertical support 904 may be rotated and/or pivoted in one or more directions with respect to the base 902. In certain embodiments, the upper connection member 926 may be a ball-and-socket type connection allowing the case 906 to be rotated and pivoted in one or more directions with respect to the vertical support 904. In certain embodiments, the upper connection member 926 may be generally described as a rotational mechanism. In various embodiments, the case may include one or more access ports 914 (e.g., power and/or data access ports).

A release lever 916 may be configured to selectively lock and release the upper connection member 926 and/or the lower connection member 908. For example, when locked, the release lever 916 may be configured to selectively prevent the case 906 from pivoting and/or rotating in one or more directions relative to the vertical support 904, the case 906, and/or the base 902. In certain embodiments, the release lever 916 may be specifically configured to selectively lock and/or release the vertical and horizontal pivoting of the case 906 relative to the vertical support 904. In some embodiments, the case 906 may be configured to rotate from a portrait to a landscape orientation regardless of the state of the release lever 916.

18

The case 906 may be secured to the upper connection member 926 via a mount 924. In certain embodiments, the case 906 and/or upper connection member 926 may be selectively detached and/or attached from the mount 924.

FIG. 38 illustrates a side elevation view of a multi-pivot stand 900. The multi-pivot stand may include a vertical support 904 rotatably coupled to a base 902 via a lower connection member 908. In certain embodiments, the lower connection member 908 may allow the vertical support 904 to be rotated and/or pivoted in one or more directions relative to the base 902.

A case 906 configured to secure a PED (not shown) may be coupled to an upper connection member 926 via a mount 924. Alternatively, the case 906 may be directly coupled to the upper connection member 926. In certain embodiments, the upper connection member 926 may be configured to rotatably couple the case 906 to the vertical support 904 such that the case 906 may be pivoted and/or rotated in one or more directions relative to the vertical support 904. A release lever 916 may be configured to selectively lock and release the movement of the upper connection member 926.

FIG. 39 illustrates a multi-pivot stand 900 including a case 906 coupled to a vertical support 904. In certain embodiments, the case 906 may be coupled to the vertical support 904 via an upper connection member 916 (shown in dashed lines). In some embodiments, the upper connection member 916 may be coupled to the case 906 via a mount 924 (shown in dashed lines).

The case 906 may be configured to pivot and/or rotate in one or more directions relative to the vertical support 904. The vertical support 904 may be coupled to the base 902 via a lower connection member 908 and may be configured to pivot and/or rotate in one or more directions relative to the base 902. A release lever 916 may be configured to selectively lock and release the upper connection member 926 and/or the lower connection member 908.

In certain embodiments, the upper connection member 926 and/or the lower connection member 908 may be configured to frictionally maintain their positions when the PED (not shown) is secured within the case 906. For example, in certain embodiments, even with the release lever 916 set to a position where the upper connection member 926 and the lower connection member 908 are free to rotate and/or pivot in one or more directions, friction may enable both connection members 926, 908 to maintain their positions until acted on by an external force (e.g., from a user repositioning the stand 900).

FIG. 40 illustrates a release lever 916 configured to selectively release an upper connection member (not visible) of a multi-pivot stand 900 in order to rotate a case 906 from a landscape orientation to a portrait orientation. As illustrated, the release lever 916 may be actuated by, for example, pulling it towards the case 906. Alternatively, the release lever 916 may be actuated by movement in another direction, by rotation in a particular direction, by pulling the lever 916 outward, and/or by pushing the lever 916 inward. In certain other embodiments, the release lever 916 may be a release button or other mechanical device configured to selectively actuate the configuration of the upper connection member 926 and/or the lower connection member 908.

FIG. 41 illustrates another view of the release lever 916 illustrated in FIG. 40. As illustrated, when the release lever 916 is actuated, the case 906 may be freely rotated from a portrait orientation to a landscape orientation. In certain embodiments, the release lever 916 is actuated, the case 906 may be rotated in one or more directions to a plurality of orientations. Alternatively, the case 906 may be configured to

19

lock (e.g., via a snapping mechanism or the like) into one or more locations and/or orientations corresponding to one or more pre-set orientations.

FIG. 42 illustrates another multi-pivot stand 900 including a case 906 configured to secure a PED (not shown) capable of rotating from a landscape orientation to a portrait orientation. In certain embodiments, a release lever (not shown) may need to be actuated prior to rotating the case 906 between orientations. Alternatively, the case 906 may be free to rotate independent of the release lever. In certain embodiments, the release lever may be configured to selectively prevent the case 906 from vertically and horizontally pivoting but not prevent it from rotating. In some embodiments, the case 906 may be figured to lock (e.g., snap) into one or more desired orientations (e.g., every 90 degrees and/or in portrait/landscape orientations). A vertical support 904 coupled to the case 906 may further be rotated and/or pivoted relative to a base 902.

FIGS. 43-44 illustrate a multi-pivot stand 900 including a case 906 configured to vertically pivot about an upper connection member (not shown). A base 902 may be coupled to a vertical support 904 that, in certain embodiments, may be rotatable and/or pivotable in one or more directions relative to the base 902. The vertical support 904 may be rotatably and/or pivotally coupled to the case 906 via an upper connection member (not visible). A release lever 916 may be configured to selectively lock and release the upper connection member and control the rotation and/or pivoting of the case 906 relative to the vertical support 904 and/or the vertical support 904 relative to the base 902.

FIGS. 45-46 illustrate a multi-pivot stand 900 including a case 906 configured to horizontally pivot about an upper connection member (not shown). A base 902 may be coupled to a vertical support 904 that, in certain embodiments, may be rotatable and/or pivotable in one or more directions relative to the base 902. The vertical support 904 may be rotatably and/or pivotally coupled to the case 906 via an upper connection member (not visible). The vertical support 904 may be further rotatably and/or pivotally coupled to the base 902 via a lower connection member 908. A release lever 916 may be configured to selectively lock and release the upper connection member and/or the lower connection member 908 and control the rotation and/or pivoting of the case 906 relative to the vertical support 904 and/or the vertical support 904 relative to the base 902. Using the upper connection member and/or lower connection member 908, the case 906 may be horizontally rotated and/or pivoted with respect to the base 902 as illustrated. In certain embodiments, rotating and/or pivoting the case 906 may require that a release lever 916 be actuated.

FIG. 47 illustrates a component view of a multi-pivot stand including a base 902, a lower connection member 908, a vertical support 904, an upper connection member 926, and a case 906 configured to secure a PED. The stand may further include a release lever 916 and a mount 924 coupled to the case 906.

The vertical support 904 may be rotatably and/or pivotally coupled to the base 902. In certain embodiments, a lower connection member 908 may comprise a ball joint that is rigidly or rotatably coupled to the vertical support 904. The lower connection member 908 may include a lower coupling pin 932 disposed thereon configured to be received by a lower coupling pin receptor 934 disposed in the base 902. In certain embodiments, the lower coupling pin 932 may be securely received by the lower coupling pin receptor 934 using a compression and/or friction fit. In other embodiments, the lower coupling pin 932 may be securely received by the lower coupling pin receptor 934 using a threaded mechanism incor-

20

porated into the lower coupling pin 932 and/or the lower coupling pin receptor 934. In further embodiments, the lower coupling pin 932 may be securely received by the lower coupling pin receptor 934 using a mechanical latching mechanism incorporated into the lower coupling pin 932 and/or the lower coupling pin receptor 934.

The vertical support 904 may be rotatably and/or pivotally coupled to the case 906. In certain embodiments, an upper connection member 926 may comprise a ball joint that is rigidly or rotatably coupled to the case 906 via, in certain embodiments, a mount 924. In some embodiments, the case 906 and/or upper connection member 926 may be selectively detached and/or attached from the mount 924.

The upper connection member 926 may include an upper coupling pin 928 disposed thereon configured to be received by an upper coupling pin receptor 930 disposed in the vertical support 904. In certain embodiments, the upper coupling pin 928 may be securely received by the upper coupling pin receptor 930 using a compression and/or friction fit. In other embodiments, the upper coupling pin 928 may be securely received by the upper coupling pin receptor 930 using a threaded mechanism incorporated into the upper coupling pin 928 and/or the upper coupling pin receptor 930. In further embodiments, the upper coupling pin 928 may be securely received by the upper coupling pin receptor 930 using a mechanical latching mechanism incorporated into the upper coupling pin 928 and/or the upper coupling pin receptor 930. In certain embodiments, a release lever 916 may be configured to selectively pivotally and/or rotationally lock and release the upper connection member 926 and/or the lower connection member 908.

FIG. 48 illustrates a base 902 and a vertical support 904 configured to be pivotally coupled via a lower connection member 1002, 1004. As illustrated, the lower connection member may comprise a base ball 1004 rigidly coupled to the base 902. A vertical support ball receptor 1002 coupled to the vertical support 904 may be configured to mechanically and/or frictionally grasp the base ball 1004. In certain embodiments, the vertical support 904 may be rotated and/or pivoted relative to the base 902 via the lower connection member 1002, 1004 independent of a selective release and locking mechanism such as, for example, a release lever. Alternatively, the vertical support 904 may be rotated and/or pivoted relative to the base 902 via the lower connection member 1002, 1004 at varying degrees of resistance based on the actuation of a selective release and locking mechanism.

FIG. 49 illustrates a base 902 and a vertical support 904 configured to be pivotally coupled via another lower connection member 1006, 1008. As illustrated, the lower connection member may comprise a vertical support ball 1006 rigidly coupled to the vertical support 904. A base ball receptor 1008 coupled to the base 902 may be configured to mechanically and/or frictionally grasp the vertical support ball 1006. In certain embodiments, the vertical support 904 may be rotated and/or pivoted relative to the base 902 via the lower connection member 1006, 1008 independent of a selective release and locking mechanism such as, for example, a release lever. Alternatively, the vertical support 904 may be rotated and/or pivoted relative to the base 902 via the lower connection member 1006, 1008 at varying degrees of resistance based on the actuation of a selective release and locking mechanism.

FIG. 50 illustrates an exemplary base 1010 and vertical support 904 configured to be pivotally coupled via a lower connection member 932, 934. As illustrated, the base 1010 may include one or more leg members that may extend onto a surface the base 1010 rests upon. The vertical support 904 may be rotatably and/or pivotally coupled to the base 1010. In

certain embodiments, a lower connection member **908** may comprise a ball joint that is rigidly or rotatably coupled to the vertical support **904**. The lower connection member **908** may include a lower coupling pin **932** disposed thereon configured to be received by a lower coupling pin receptor **934** disposed in the base **902**. In certain embodiments, the lower coupling pin **932** may be securely received by the lower coupling pin receptor **934** using a compression and/or friction fit. In other embodiments, the lower coupling pin **932** may be securely received by the lower coupling pin receptor **934** using a threaded mechanism incorporated into the lower coupling pin **932** and/or the lower coupling pin receptor **934**. In further embodiments, the lower coupling pin **932** may be securely received by the lower coupling pin receptor **934** using a mechanical latching mechanism incorporated into the lower coupling pin **932** and/or the lower coupling pin receptor **934**.

FIGS. **51-52** illustrate a holder **1100** for a PED. The holder **1100** may include a case **1102**, a hand grip **1104**, and a coupling mechanism **1106, 1108** configured to securely attach the hand grip **1104** to the case **1102**. The case **1102** may be configured to receive, secure, and carry a PED and may incorporate features of other embodiments of cases disclosed herein.

The hand grip **1104** may include a base plate **1110** and a strap **1112** coupled to the base plate **1110**. In certain embodiments, a user may be able to slip a part of an appendage (e.g., a hand or forearm) between the base plate **1110** and the strap **1112** to secure the base plate **1110** to the user. In certain embodiments, the strap **1112** may be formed integrally with the base plate **1110**. In other embodiments, the strap **1112** may pass through and/or wrap around at least a portion of the base plate **1110**.

The inside of the strap **1112** and/or the base plate **1110** may be lined at least in part with a pad and/or soft material (e.g., microfiber) to provide comfortable use. In certain embodiments, the base plate **1110** may be a circular shape, as illustrated, to comfortably conform to the palm of a user's hand. In other embodiments, the base plate **1110** may comprise any suitable and/or ergonomic shape.

The coupling mechanism **1106, 1108** may be configured to detachably secure the base plate **1110** of the hand grip **1104** to the case **1102**. In certain embodiments, the coupling mechanism **1106, 1108** may couple the hand grip **1104** to the case in a manner that allows the hand grip **1104** to be rotatable relative to the case **1102**. In the illustrated embodiment, the coupling mechanism **1106, 1108** comprises hooks and loops, such as Velcro®, which can easily be separated to allow rotation. For example, a loop portion **1108** may be securely attached to the case **1102**, and a hook portion **1106** may be securely attached to the hand grip **1104**.

The hand grip **1104** may be secured to the case **1102** when the hook portion **1106** and the loop portion **1108** come into contact. The hand grip **1104** can be rotated relative to the case **1102** by separating the hook portion **1106** and the loop portion **1108** (i.e., by separating the hand grip **1104** from the case **1102**), rotating the hand grip **1104** as desired, and recoupling the hook portion **1106** and the loop portion **1108**. In certain embodiments, the coupling mechanism **1106, 1108** allows rotation of the case **1102** relative to the hand grip **1104** to any desired degree, including positions less than ninety degrees, thereby allowing the user to find a rotational orientation of the case **1102** that is comfortable. In other embodiments, the coupling mechanism **1106, 1108** may be configured such that only selected orientations are permitted. For example, in one embodiment, the coupling mechanism **1106, 1108** may be configured to only accept a rotational orientation of the case **1102** at **90** degree intervals.

The loop portion **1108** may be attached to the case **1102** with an adhesive. In another embodiment, the loop portion **1108** may be formed integrally with the case **1102**. Similarly, the hook portion **1106** may be attached to the base plate **1110** of the hand grip **1104** with an adhesive, or may be integrally formed with the base plate **1110**.

The coupling mechanism **1106, 1108** can be any suitable securement device that allows the case **1102** to be rotated relative to the hand grip **1104**. For example, the coupling mechanism **1106, 1108** may include a ratcheting swivel or pivot, a rotating grommet mechanism, a ball and socket mechanism, a temporary adhesive, a releasable latch, a clip, one or more buttons, a suction cup, and/or one or more straps allowing for rotational securement.

In certain embodiments, the coupling mechanism **1106, 1108** may couple directly to a PED (not shown). For example, the loop portion **1108** may be constructed and arranged to be attached directly to the back of a PED. An adhesive designed to adhere to the back of the PED may be applied to the back of the loop portion **1108**. In other embodiments, the hook portion **1106** may include an adhesive to attach directly to the PED.

FIGS. **53-56** illustrate a holder **1200** for a PED (not shown) in a handheld configuration. The holder **1200** may include a case **1202** configured to receive, secure, and retain a PED, and a sheath **1204**. The sheath **1204** may be constructed and arranged to releasably secure to the case **1202**. For example, the case **1202** may include one or more cleats **1206, 1208** and the sheath **1204** may include one or more holes **1210** constructed and arranged to releasably attach the sheath **1204** to the cleats **1206, 1208**.

FIG. **53** illustrates a back perspective view of the holder **1200** with the sheath **1204** detached from the case **1202**. FIG. **54** illustrates a back perspective view of the holder **1200** with the holes **1210** of the sheath **1204** attached to a pair of cleats **1208** in a first orientation. A user can insert a hand or other appendage in between the sheath **1204** and the case **1202** and the sheath **1204**, such that the holder **1200** can be secured to the user. In FIG. **54**, the holder **1200** with the sheath **1204** in the first orientation is configured to be secured such that when the user's hand is positioned with fingers aligned horizontally across the user's body, the PED is oriented in a portrait orientation. Alternatively, if the user's hand is positioned with the fingers aligned vertically, the PED may be oriented in a landscape orientation. In other embodiments, the sheath **1204** can also function as a handle, such that a user can simply grasp the sheath **1204**. Accordingly, the sheath **1204**, in combination with the grasp of a user, can secure the case **1202** and PED disposed therein to a user.

The sheath **1204** can be detached from the first pair of cleats **1206**, as shown in FIG. **56**, rotated relative to the case **1202**, and attached to a second pair of cleats **1208** on the case **1202**, as shown in FIG. **54**. In this manner, the sheath **1204** may be rotatable to allow use of the PED in a portrait orientation or a landscape orientation. In certain embodiments, cleats **1206, 1208** may be attached directly to the PED rather than to the case **1202**. Further, in certain embodiments, any number of cleats **1206, 1208** may be included allowing for multiple viewing orientations including, or in addition to, a portrait orientation and/or a landscape orientation. Additional holes **1210** can be included on the sheath **1204** to allow for adjustable sizing and/or tension of the sheath **1204** to accommodate varying user hand sizes. Additionally, the inside of the sheath **1204** may be lined with a microfiber material and or a pad to provide comfortable use.

FIG. **55** is a top perspective view of the case **1202**, and a side view of the sheath **1204**. The sheath **1204** may include

one or more notches **1212** that, in certain embodiments, may be shaped and configured to receive an end of the case **1202**. The sheath **1204** may be formed of a flexible material that can be bent into substantially a “U” shape, such that the end of the case **1202** can be inserted into notches **1212**.

FIGS. **57-58** illustrate a holder **1200** for a PED (not shown) in a stand configuration. As illustrated, the bottom edge of the sheath **1204** can be set on a table or other flat surface and can function as a stand for the PED when an end of the case **1202** is disposed in the notches **1212**. The sheath **1204** may also be configured to receive the PED at different orientations such that the user can insert the case **1202** and/or the PED **102** therein and view the display from a landscape orientation or, alternatively, a portrait orientation.

In certain embodiments, the sheath **1204** can include a pocket into which the user’s hand or other appendage may be inserted. In other embodiments, the sheath **1204** may include an opening through which a user’s hand can be inserted. The positioning of the cleats **1206**, **1208** may be adjustable (e.g., adjustable via a sliding mechanism), to adjust sizing and/or positioning of the sheath **1204** relative to the case **1202** and/or PED. In other embodiments, the cleats **1206**, **1208** may be detachable or configured to be disposed within (i.e., pushed into) the case **1202** when not in use.

FIGS. **59-62** illustrate a rotatable holder **1300** for a PED **102**. The holder **1300** may include a case **1302**, a hand grip **1304**, and a rotatable coupling member **1306** to rotatably attach the hand grip **1304** to the case **1302**. The case **1302** may be configured to receive, secure, and carry the PED **102**, and may include any combination of the various features and embodiments described in any of the cases described herein.

The case **1302** may further comprise one or more kickstands **1308** that may be constructed and arranged to prop up the case **1302** in a viewing position. In certain embodiments, the kickstands **1308** may be recessed into the case **1302** when not in use, and may rotate out from the case **1302** to prop up the case **1302**, as illustrated in FIG. **61** and FIG. **62**. In this manner, the kickstands **1308** may allow the case **1302** to operate as a stand to support the PED **102** in a substantially upright and/or elevated position. A first kickstand **1308** may prop the case upright and/or elevated in a landscape orientation, as illustrated in FIG. **61**, and a second kickstand **1308** may prop the case upright and/or elevated in a portrait orientation, as illustrated in FIG. **62**.

The hand grip **1304** may include a knob or similar structure (e.g., a bulb, a handle, etc) that a user can easily grasp. The hand grip **1304** in combination with a user’s grasp may secure the case relative to the user’s hand. In the illustrated embodiments, the hand grip **1304** is substantially a half sphere. As can be appreciated, the hand grip **1304** may be formed in any suitable shape that can be easily grasped by a user. Hand grip **1304** may also include finger depressions designed to comfortably receive one or more of a user’s fingers. In certain embodiments, the hand grip **1304** can be a mitt and/or similar glove-like or pocket-like structure coupled to the case **1302** by the rotatable coupling member **1306**. The mitt can be constructed and arranged with an opening to receive a hand of a user. The mitt may receive the hand of the user with the palm facing toward the back of the case **1302**, and may also be configured to receive the hand of the user with the palm facing away from the case **1302**. The mitt may further include a mounting plate to provide a rigid surface for attaching the mitt to the rotatable coupling member **1306**.

The rotatable coupling member **1306** may be configured to rotatably secure the hand grip **1304** to the case **1302**. In the illustrated embodiment, the coupling member **1306** may comprise a ratcheted swivel. The rotatable coupling member

1306 may allow the case **1302** to rotate relative to the hand grip **1304** without decoupling the case **1302** from the hand grip **1304** and without a user releasing the hand grip **1304**. The rotation allowed by the rotatable coupling member **1306** may be within a plane substantially parallel to a plane of the back surface of the case **1302** or a plane of the back surface of a PED **102** retained within the case **1302**. Accordingly, the rotation of the rotatable coupling member **1306** may facilitate rotation of the PED **102** between a variety of orientations including, for example, a portrait orientation and a landscape orientation. In certain embodiments, the rotatable coupling member **1306** may allow rotation up to at least ninety degrees, from portrait orientation to landscape orientation. The rotatable coupling member **1306** may also allow 360 degree rotation, such that the PED **102** can be rotated to any angle.

A ratcheting mechanism included within the rotatable coupling member **1306** may substantially secure the case **1302** relative to the hand grip **1304** at various increments of rotation. The ratcheting mechanism may be formed by a plurality of female detents interacting with one or more projecting members, such as spheres or half spheres that catch a detent as it passes during rotation. The rotatable coupling member **1306** may allow rotation of the case **1302** relative to the hand grip **1304** to substantially any desired degree, including points less than ninety degrees, thereby allowing the user to find a rotational orientation of the case **1302** that is comfortable. In certain embodiments, the rotatable coupling member **1306** may be configured such that the rotation may only lock into place at 90-degree intervals that correspond with the landscape and portrait orientations of the PED **102**.

FIGS. **63-65** illustrate a handheld holder **1400** for a PED **102**. The holder **1400** may include a case **1402**, and a hand pocket **1404** attached to the case **1402**. The case **1402** may be configured to receive, secure, and carry the PED **102**, and may include any combination of the various features and embodiments described in any of the cases described herein.

The hand pocket **1404** can be coupled to the back of the case **1402** and be configured to receive a hand of a user. In certain embodiments, the hand pocket **1404** can be constructed and arranged to receive a hand of a user such that a PED **102** inserted into the case **1402** is oriented in a portrait orientation and also constructed and arranged to receive the hand of the user such that the PED **102** is oriented in a landscape orientation. The hand pocket **1404** may be stitched to the back of the case **1402**, or otherwise secured using any appropriate securement method or device, including but not limited to an adhesive, hooks and loops, buttons, one or more zippers, and/or clamps. The hand pocket **1404** may also be integrated into the case **1402**.

The hand pocket **1404** may include a first opening **1406** to receive a hand of a user and thereby secure the PED **102** relative to the hand of the user. The PED **102** may be secured relative to the hand of the user such that when the user raises the hand substantially near the abdomen or chest, the PED **102** may be oriented in a portrait orientation. In certain embodiments, the user’s hand may be received into the hand pocket **1404** with the palm facing toward the back of the PED **102** or, alternatively, with the palm facing away from the PED **102**.

The hand pocket **1404** may further include a second opening **1408** to receive the hand of the user and thereby secure the PED **102** relative to the hand of the user such that the PED **102** is oriented in a landscape orientation. In such embodiments, the user may remove a hand from the first opening **1406** and insert the hand into the second opening **1408** to change the orientation of the PED **102**. In this manner the case **1402** is

rotatable at least ninety degrees and allows operability of the PED 102 in either a portrait or a landscape orientation.

In some embodiments, the holder 1400 may include a pocket 1404 that further includes a third opening 1410 opposite the first opening 1406 and a fourth opening 1412 opposite the second opening 1408. Using these openings 1406, 1408, 1410, and 1412, a hand can be inserted into the hand pocket 1404 from any of four directions separated by ninety degrees, thus allowing orientation of the PED 102 in either of two possible landscape orientations (e.g., a first landscape orientation and then a second landscape orientation at 180 degrees from the first) and in either of two possible portrait orientations (e.g., a first portrait orientation and then a second at 180 degrees from the first). Furthermore, the fingers of a hand inserted into the third opening 1410 may extend partially out of the first opening 1406, as illustrated in FIG. 64. Similarly, the fingers of a hand inserted into the second opening 1408 may extend partially out of the fourth opening 1412.

As illustrated in FIG. 65, the hand pocket 1404 may be connected to the PED 102 and/or case 1402 via a rotatable coupling mechanism 1414, such as a grommet or any other rotatable connection and/or mechanism described herein. In certain embodiments, the pocket 1404 may comprise a slightly rigid or reinforced side configured to be positioned adjacent to the PED 102 and/or the case 1402 and to be coupled to the rotatable coupling mechanism 1414.

FIGS. 66-67 illustrate a handheld holder 1500 for a PED (not shown). The holder 1500 may include a case 1502 and one or more hand pockets 1504, 1506 coupled to the case 1502. The case 1502 may be configured to receive, secure, and carry the PED, and may include any combination of the various features and embodiments described in any of the cases described herein.

One hand pocket 1506 may be oriented to receive a hand of a user and thereby secure the holder such that a PED secured in the case 1502 is oriented in a portrait orientation. Another hand pocket 1504 may be oriented to receive the hand of the user and thereby secure the holder such that a PED secured in the case 1502 is oriented in a landscape orientation. The user can insert the hand into either of the hand pockets 1504, 1506, depending on the desired orientation of the PED. In this manner, the case 1502 is rotatable at least ninety degrees and allows operability of the PED in either a portrait or a landscape orientation. In another embodiment, the holder 1500 may comprise additional hand pockets 1504, 1506 to allow additional degrees of rotation.

The hand pockets 1504, 1506 may be stitched to the back of the case 1502, or otherwise be secured using any appropriate securement method or device, including but not limited to an adhesive, hook and loop mechanisms, buttons, one or more zippers, and/or clamps. The hand pockets 1504, 1506 may also be integrated into the case 1502. In certain embodiments, the hand pockets 1504, 1506 may be movable to one or more positions on the back of the case 1502. For example, a back side of the case 1502 may include a loop portion of a hook and loop mechanism, and the hand pockets 1504, 1506 may be attached anywhere on the backside of the case 1502 using a hook portion disposed thereon. In this manner, the hand pockets 1504, 1506 may be positioned on the case 1502 to allow for a variety of viewing orientations.

FIGS. 68-69 illustrate a case 1600 for a PED (not shown). The case 1600 may be configured to receive, secure, and carry the PED, and may include any combination of the various features and embodiments described in any of the cases described herein. As illustrated, the case may include one or more kickstands 1604 configured to allow the case 1600 to function as a stand depending on the orientation of the kick-

stands 1604 (e.g., depending on whether kickstands are deployed). In certain embodiments, the kickstands 1604 may be recessed into the case 1600 when not in use to prop the case 1600 in an upright and/or elevated position, and may rotate out from the case 1600 for use, as illustrated. The kickstands 1604 may allow the case to operate as a stand to support a PED in a substantially upright and/or elevated position. A first kickstand 1604 may prop the case 1600 upright and/or elevated in a landscape orientation, as illustrated in FIG. 68, and a second kickstand 1604 may prop the case 1600 upright and/or elevated in a portrait orientation, as illustrated in FIG. 69.

The case 1600 may also include a cover 1602 configured to be positioned over a PED inserted into the case 1600 and to substantially enclose and/or protect the PED. In certain embodiments, the cover 1602 may snap into the case 1600, thereby enclosing a PED disposed therein. In other embodiments, the cover 1602 may be strapped or fastened using any other mechanical means into the case 1600. In certain embodiments, the cover 1602 can be used to protect a PED disposed within the case 1600 when the PED is not in use. In other embodiments, the cover 1602 may comprise a transparent window through which a user can view and/or manipulate the PED, and thus the cover 1602 can remain positioned over the PED, both during use and when not in use. In certain embodiments, a window included in the cover 1602 may be permanently open or may alternatively be selectively openable.

FIG. 70 illustrates a handheld holder 1700 for a PED (not shown). The handheld holder 1700 may comprise a case 1702 and a hand pocket 1704 coupled to the case 1702 via a rotatable coupling mechanism 1706. In certain embodiments, the rotatable coupling mechanism 1706 may be a grommet or any other rotatable connection and/or mechanism described herein, and may be coupled directly to a PED rather than the case 1702. The case 1702 may be configured to receive, secure, and carry the PED, and may include any combination of the various features and embodiments described in any of the cases described herein. Further, the hand pocket 1704 may be a pocket, a strap, a pouch, a knob, a handle, and or any interface allowing a user's hand or other appendage to grasp or otherwise be secured into the hand pocket 1704.

The rotatable coupling mechanism 1706 may allow a PED disposed in the case 1702 to be viewed in a variety of viewing orientations relative to the hand pocket 1704. For example, in certain embodiments, a user may secure the hand pocket 1704 in a particular position (e.g., by securing a hand in the hand pocket 1704 or the like), and rotate the case 1702 in a variety of orientations relative to the hand pocket 1704 using the rotatable coupling mechanism 1706. In certain embodiments, the rotatable coupling mechanism 1706 may be configured to have one or more locking positions where the rotatable coupling mechanism 1706 requires a higher degree of rotational resistance to move the rotatable coupling mechanism from the non-locking positions. For example, the rotatable coupling mechanism 1706 may include locking positions where the case 1702 relative to the hand pocket 1704 is in a portrait orientation and a landscape orientation.

FIGS. 71-73 illustrate a rotatable coupling mechanism 1706. The rotatable coupling mechanism 1706 may be included in any of the case designs detailed herein and be used in such designs to change the orientation of a PED to one or more desired orientations (e.g., landscape and/or portrait). The rotatable coupling mechanism 1706 may be substantially any cylindrical shape (e.g., a long shaft, a short cylinder similar to a hockey puck, etc.) and may comprise two complementary halves 1708, 1710 configured to rotate relative to

each other and interact so as to create one or more locking positions. The complementary surfaces of the halves **1708**, **1710** may comprise one or more protrusions **1712** and one or more depressions **1714** to implement a locking position. The protrusions **1712** of a first half **1708** may complement and conform to the depressions **1714** of a second half **1710**, as illustrated in FIG. 72. Similarly, the protrusions **1712** of the second half **1710** may complement and conform to the depressions **1714** of the first half **1708**. As the first half **1708** rotates relative to the second half **1710**, the protrusions **1712** of the first half **1708** may rotate between non-locking positions (i.e., where the protrusions **1712** of the first half **1708** abut the protrusions **1712** of the second half **1710**) and locking positions (i.e., where the protrusions **1712** of the first half **1708** abut the depressions **1714** of the second half **1710**). The protrusions **1712** and depressions **1714** may alternate as illustrated and may be any functionally appropriate shape including, a wave shape, a set of complementary teeth, and the like.

In certain embodiments, the protrusions **1712** may have a rounded shape and be configured such that a first protrusion **1712** on a first half **1708** allows a second protrusion **1712** on the opposing second half **1710** to smoothly rotate over and past the first protrusion as the halves **1708**, **1710** rotate relative to one another. Similarly, the depressions **1714** may have a rounded shape. Moreover, the transition from a protrusion **1712** to a depression **1714** may be seamless and continuous to form a gentle rounded surface as illustrated. Accordingly, the halves **1708**, **1710** can easily be rotated relative to one another, and thereby transitioned between locking positions, while the halves **1708**, **1710** are in abutment to one another and without being separated.

In other embodiments, the protrusions **1712** may be jagged without a rounded shape. For example, the protrusions **1712** may comprise complementary teeth. In some embodiments, the teeth may be triangular in shape, alternating between protrusions **1712** and depressions **1714**. In certain embodiments, the halves **1708**, **1710** may need to be pulled apart and separated before rotation can occur. In other embodiments, the transition from protrusion **1712** to depression **1714** may be more pronounced and/or non-continuous, such that there is a separation between each protrusion **1712** and depression **1714**.

In the illustrated embodiments, each half **1708**, **1710** comprises four protrusions **1712** and four depressions **1714**. Accordingly, the rotatable coupling mechanism **1706** comprises four locking positions. The four locking positions may each correspond to ninety degrees of rotation. As can be appreciated, additional protrusions **1712** and depressions **1714** may be provided so as to allow additional locking positions at smaller degrees of rotation. Moreover, fewer protrusions **1712** and depressions **1714** may be provided as well to provide fewer locking positions.

The rotatable coupling mechanism **1706** may further comprise a connecting member **1716**, such as a rod or elastic piece, configured as an axis about which the halves **1708**, **1710** rotate. The connecting member **1716** may also secure the halves **1708**, **1710** relative to one another. In some embodiments, the connecting member **1716** may include one or more biasing members configured to urge the first half **1708** and second half **1710** together. For example, the connecting member **1716** may pass through the two halves **1708**, **1710** and be spring-loaded with springs **1718** on the outside of the two halves **1708**, **1710** to push the two halves **1708**, **1710** together. Alternatively, the connecting member **1716** itself may comprise a biasing member, such as a spring **1718** or an elastic material, that may provide a biasing force, as illustrated in FIG. 73. The biasing force may be provided to urge

the halves **1708**, **1710** toward one another. The biasing force may also urge the rotatable coupling mechanism **1706** toward a locking position (i.e., by urging the protrusions **1712** of the first half **1708** toward a position abutting the depressions **1714** of the second half **1710** and vice versa). In other embodiments, an external force such as, for example, gravity may provide a biasing force to urge the halves **1708**, **1710** toward one another.

FIGS. 74-77 illustrate a rotatable case **1800** for a PED **102**. The case **1800** may include a holder **1802** configured to receive, secure, retain, and carry the PED **102**, and may include any combination of the various features and embodiments described in any of the cases and/or holders described herein. As illustrated, the holder **1802** may be configured to retain the PED **102** by mechanically securing the PED **102** at its corners. In certain embodiments, the holder **1802** may retain the PED **102** using a compression and/or snap fit mechanism.

The case **1800** may further include a cover **1804**, **1806** comprising a base portion **1804** and a support portion **1806**. The base portion **1804** and the support portion **1806** may be coupled at a fold **1808** allowing for the base portion **1804** to hinge with respect to the support portion **1806**. In certain embodiments, the base portion **1804** and the support portion **1806** may be formed integrally and the fold **1808** may be formed as part of the base portion **1804** and the support portion **1806**. In other embodiments, the base portion **1804**, the support portion **1806**, and the fold **1808** may be separate components. In certain embodiments, the holder **1802** and/or the cover **1804** may provide protection to an enclosed PED **102**. For example, the holder **1802**, the base portion **1804**, and/or the support portion **1806** may be reinforced with padding, metal, plastic, cardboard, rubber, and/or other materials or any combination thereof.

In certain embodiments, the fold **1808** may include various folds, bends, and/or curvatures in material to obtain desirable resistance and/or resilience characteristics. For the example, the fold **1808** may be configured to function as a bi-stable, tri-stable, or N-stable fold, allowing a user to selectively vary the relative angle between the base portion **1804** and the support portion **1806** into one or more predetermined angles. In some embodiments utilizing an N-stable fold, the support portion **1806** may effectively "snap" into one or more predetermined positions relative to the base portion **1804**.

The base portion **1804** may be coupled to a vertical support **1810** via a hinge **1812**. In certain embodiments, the vertical support **1810** may be configured to support in part the holder **1802** in an upright and/or elevated position allowing for viewing of the display **104** of the PED **102**. The vertical support **1810** may be coupled to the holder **1802** via a rotational mechanism **1814** allowing for variable rotation of the holder **1802** relative to the vertical support **1810**. For example, as illustrated in FIG. 77, the rotational mechanism **1814** may include a rotational grommet secured to the vertical support **1810** and the holder **1802** allowing for variable rotation of the holder **1802** relative to the vertical support **1810**. In other embodiments, the rotational mechanism **1814** may include a ratcheting swivel or pivot, a ball and socket mechanism, a temporary adhesive, a releasable latch, a clip, one or more buttons, a suction cup, and/or one or more straps allowing for rotational securement. In certain embodiments, the rotational mechanism **1814** may snap into certain specific rotational orientations (e.g., portrait orientation, as illustrated in FIG. 75, and/or landscape orientation, as illustrated in FIG. 74) and require rotational force to move to a different specific orientation. In alternative embodiments, the rotation mechanism **1814** may not snap into specific orientations but may allow

for rotational articulation in any number of orientations. Further, in certain embodiments, the vertical support **1810** may be coupled to the holder **1802** via a non-rotatable connection including, for example, a fixed and/or hinged mechanism.

The vertical support **1810** may be configured to allow for its length to be adjusted using a sliding track or similar adjustable mechanism. In some embodiments, by adjusting the length of the vertical support **1810**, the relative distance between the base portion **1804** and the holder **1802** may be adjusted. In certain embodiments, the length of the vertical support **1810** may be configured to be adjusted to one or more predetermined positions via a selective locking mechanism or the like. In other embodiments, the vertical support **1810** may have a fixed length.

As illustrated in FIG. 77, the back of the vertical support **1810** may include one or more channels **1816**. In some embodiments, the channels may be configured to receive an edge of the support portion **1806**. To configure the case **1800** to support the PED **102** in an upright and/or elevated position, the base portion **1804** may be rotated relative to the vertical support **1810** about the hinge **1812** and rested on a work surface. The angle of the support portion **1806** may be adjusted relative to the base portion **1804** via the fold **1808**, thereby adjusting a viewing angle of the PED **102** included in the holder **1802**. When a desired angle is achieved, an end of the support portion **1804** may be positioned in one of the channels **1816**, allowing for the desired viewing angle to be sustained by the case **1800**. In some embodiments, the end of the support portion **1806** may be secured in the channels **1816** via a compression fit. In other embodiments, a selective securement mechanism may be used to secure the end of the support portion **1806** in the channels **1816** that may include a magnetic connection, a snap, a button, a clip, or the like.

When the PED **102** is not in use, the case **1800** may be reconfigured by a user into a stowage configuration, as illustrated in FIG. 76. To reconfigure the case **1800** in a stowage configuration, the base portion **1804** and the support portion **1806** may be articulated around the hinge **1812** so as to cover the display **104** of the PED **102**. In such a configuration, the fold **1808** may be adjusted to allow the base portion **1804** and the support portion **1806** to be substantially co-planar. In certain embodiments, reconfiguration of the case **1800** in a stowage configuration may require that the length of the vertical support **1810** be adjusted using a sliding track mechanism or the like. In some embodiments, the base portion **1804** and the support portion **1806** may be secured to the holder **1802** and/or the PED **102** in the stowage configuration via a magnetic connection, one or more releasable clips, straps, and/or other locking mechanisms allowing for the case **1800** to be selectively locked into a stowage configuration and selectively released from the stowage configuration.

FIGS. 78-81 illustrate a support **1900** for a PED **102**. The support **1900** may include a holder **1902**, **1904** configured to receive, secure, retain, and carry the PED **102**, and may include any combination of the various features and embodiments described in any of the cases and/or holders described herein. As illustrated, the holder **1902**, **1904** may be configured to retain the PED **102** by mechanically securing the PED **102** using a compression fit mechanism or the like. In certain embodiments, the holder **1902**, **1904** may include a main portion **1902** and a selectively removable top portion **1904**. A PED **102** may be disposed within the main portion **1902** when the top portion **1904** is removed and securely locked within the main portion **1902** when the top portion **1904** is securely coupled to the main portion **1902** using a selective latching mechanism **1906** or the like. In some embodiments, the main

portion **1902** and the top portion **1904** may be aligned using one or more ribs and/or channels or similar alignment mechanism.

In certain embodiments, the holder **1902**, **1904** may further comprise one or more kickstands **1908** that may be configured and arranged to prop up the holder **1902**, **1904** in a viewing position. The kickstand **1908** may be recessed into the holder **1902**, **1904** when not in use, as illustrated in FIG. 78 and FIG. 79, and may be rotated out from the holder **1902**, **1904** via a hinge **1910** to prop up the holder **1902**, **1904**, as illustrated in FIG. 80 and FIG. 81. In this manner, the kickstand **1908** may allow the support **1900** to operate as a stand to support the PED **102** disposed in the holder **1902**, **1904** in a substantially upright and/or elevated position. In certain embodiments, by adjusting the angle of the kickstand **1908** relative to the holder **1902**, **1904**, a viewing angle of a PED **102** disposed within the support **1900** may be adjusted. For example, by increasing the degree to which the kickstand **1908** is rotated out from the holder **1902**, **1904** via the hinge **1910**, the PED **102** may be viewed at a less upright and/or elevated angle. Similarly, by decreasing the degree to which the kickstand **1908** is rotated out from the holder **1902**, **1904**, the PED **102** may be viewed at a more upright and/or elevated angle. In certain embodiments, the hinge **1910** may be configured to allow the kickstand **1908** to rotate out from the holder **1902**, **1904** at one or more predetermined angles using, for example, a ratcheting mechanism or the like.

The length of the kickstand **1908** may be adjusted using a sliding and/or ratcheting mechanism **1912**. In certain embodiments, by adjusting the length of the kickstand **1908**, the relative viewing angle of the PED **102** disposed within the support **1900** may be adjusted. For example, by lengthening the kickstand **1908**, the PED **102** may be viewed at a more upright and/or elevated angle. Similarly, by shortening the kickstand **1908**, the PED **102** may be viewed at a less upright and/or elevated angle. In certain embodiments, the length of the kickstand **1908** may be configured to be adjusted to one or more predetermined positions via a selective locking mechanism **1914** or the like. In alternative embodiments, the kickstand **1908** may have a fixed length.

A rest **1916** may be disposed at an end of the kickstand **1908** and be configured to rest on a working surface when the support **1900** is in use. In certain embodiments, the rest **1916** may include one or more edges configured to be positioned parallel to a working surface when the support **1900** is oriented in one or more orientations. For example, as illustrated in FIG. 80, the rest **1916** may include an edge configured to sit parallel to a working surface when the PED **102** is viewed in a portrait configuration. Similarly, as illustrated in FIG. 81, the rest **1916** may include an edge configured to sit parallel to a working surface when the PED **102** is viewed in a landscape orientation. In this manner, by lifting and rotating the support **1900**, a PED **102** disposed therein may be viewed in a landscape and/or a portrait orientation. In certain embodiments, the rest **1916** may comprise a material configured to prevent the rest **1916** from easily sliding along the work surface (e.g., rubber or the like).

FIGS. 82-84 illustrate a rotatable support **2000** for a PED **102**. The support **2000** may include a holder **2002**, **2004** configured to receive, secure, retain, and carry the PED **102**, and may include any combination of the various features and embodiments described in any of the cases and/or holders described herein. As illustrated, the holder **2002**, **2004** may be configured to retain the PED **102** by mechanically securing the PED **102** using a compression fit mechanism or the like. In certain embodiments, the holder **2002**, **2004** may include a main portion **2002** and a selectively removable top portion

2004. A PED **102** may be disposed within the main portion **2002** when the top portion **2004** is removed and securely locked within the main portion **2002** when the top portion **2004** is securely coupled to the main portion **2002** using a selective latching mechanism or the like. In certain embodiments, a depression **2006** integrated into the main portion **2002** and/or the top portion **2004** may be utilized by a user to aid in removing the top portion **2004** from the main portion **2002**. In some embodiments, the main portion **2002** and the top portion **2004** may be aligned using one or more ribs and/or channels or a similar alignment mechanism.

The holder **2002**, **2004** may define a window allowing for a display **104** of the PED **102** to be viewed by a user. Further, the holder **2002**, **2004** may include one or more access windows **2008** allowing for PED **102** accessories (e.g., cameras) and/or interfaces (e.g., buttons, switches, knobs, etc.) to be accessed through the holder **2002**, **2004**.

The holder **2002**, **2004** may further comprise one or more kickstands **2010** that may be configured and arranged to prop up the holder **2002**, **2004** in a viewing position. The kickstand **2010** may be recessed into the holder **2002**, **2004** when not in use, as illustrated in FIG. **82**, and may be rotated out from the holder **2002**, **2004** via a hinge **2012** to prop up the holder **2002**, **2004**, as illustrated in FIG. **83**. In this manner, the kickstand **2010** may allow the support **2000** to operate as a stand to support the PED **102** disposed in the holder **2002**, **2004** in a substantially upright and/or elevated position. In certain embodiments, by adjusting the relative angle of the kickstand **2010** relative to the holder **2002**, **2004**, a viewing angle of a PED **102** disposed within the support **2000** may be adjusted. For example, by increasing the degree to which the kickstand **2010** is rotated out from the holder **2002**, **2004** via the hinge **2012**, the PED **102** may be viewed at a less upright and/or elevated angle when a rest **2014** included on the end of the kickstand **2010** is placed on a working surface. Similarly, by decreasing the degree to which the kickstand **2010** is rotated out from the holder **2002**, **2004**, the PED **102** may be viewed at a more upright and/or elevated angle when a rest **2014** included on the end of the kickstand **2010** is placed on a working surface. In some embodiments, the hinge **2012** may be configured to allow the kickstand **2010** to rotate out from the holder **2002**, **2004** at one or more predetermined angles using, for example, a ratcheting mechanism or the like. In certain embodiments, the rest **2014** may comprise a material configured to prevent the rest **2014** from easily sliding along the work surface (e.g., rubber or the like).

The length of the kickstand **2010** may be adjusted using a sliding and/or ratcheting mechanism **2016**. In certain embodiments, by adjusting the length of the kickstand **2010**, the relative viewing angle of the PED **102** disposed within the support **2000** may be adjusted. For example, by lengthening the kickstand **2010**, the PED **102** may be viewed at a more upright and/or elevated angle. Similarly, by shortening the kickstand **2010**, the PED **102** may be viewed at a less upright and/or elevated angle. In certain embodiments, the length of the kickstand **2010** may be configured to be adjusted to one or more predetermined positions via a selective locking mechanism or the like. In alternative embodiments, the kickstand **2010** may have a fixed length.

In certain embodiments, the kickstand **2010** may be coupled to the holder **2002**, **2004** via a rotational mechanism **2018**. In certain embodiments, the rotational mechanism **2018** may include a rotational grommet secured to the hinge **2012** and the kickstand **2010** allowing for variable rotation of the kickstand **2010** relative to the holder **2002**, **2004**. In other embodiments, the rotational mechanism **2018** may include a ratcheting swivel or pivot, a ball and socket mechanism, a

temporary adhesive, a releasable latch, a clip, one or more buttons, a suction cup, and/or one or more straps allowing for rotational securement. In certain embodiments, the rotational mechanism **2018** may snap into certain specific rotational orientations (e.g., portrait orientation and/or landscape orientation) and require rotational force to move to a different specific orientation. In alternative embodiments, the rotation mechanism **2018** may not snap into specific orientations but may allow for rotational articulation in any number of orientations. Further, in certain embodiments, the kickstand **2010** may be coupled to the holder **2002**, **2004** via a non-rotatable connection including, for example, a fixed and/or hinged mechanism.

In some embodiments, the support **2000** may not include a holder **2002**, **2004**, and the kickstand **2010** may be coupled to the PED **102** directly or via a rotation mechanism **2018**. In certain embodiments, the kickstand **2010** and or rotation mechanism **2018** may be coupled to the PED **102** using one or more straps, buckles, clips, adhesives, and/or other mechanical structures integrated into the PED **102** and/or the kickstand **2010** and/or rotation mechanism **2018**.

FIGS. **85-86** illustrate a handheld holder **2100** for a PED **102**. The handheld holder **2100** may include a case **2102** configured to receive, secure, retain, and carry the PED **102**, and may include any combination of the various features and embodiments described in any of the cases and/or holders described herein. As illustrated, the case **2102** may be configured to retain the PED **102** by mechanically securing the PED **102** about an outer periphery thereof. In certain embodiments, the case **2102** may retain the PED **102** using a compression and/or snap fit mechanism.

A hand grip **2104** may be included on a back of the handheld holder **2100**. In certain embodiments, the hand grip **2104** may be mounted to a rotational mechanism **2110** coupled to the back of the case **2102**. The hand grip **2104** may include a center hub **2108** and one or more straps **2106** extending outward therefrom and coupled to an outer periphery of the rotational mechanism **2110**. A user may be able to slip a part of an appendage (e.g., a hand or forearm as illustrated in FIG. **85**) between the rotational mechanism **2110** and the straps **2106** to secure the case **2102** to the user. In certain embodiments, the hand grip **2104** may be formed integrally with the rotational mechanism **2110**. In other embodiments, the hand grip **2104** or a portion thereof (e.g., the straps **2106**) may pass through and/or wrap around at least a portion of the rotational mechanism **2110**.

The center hub **2108** may include a mechanism such that when it is rotated, the length of the one or more straps **2106** extending outward therefrom are adjusted. For example, when the center hub **2108** is rotated in a particular direction, the length of the one or more straps **2106** may be shortened. Similarly, when the center hub **2108** is rotated in a different direction, the length of the one or more straps may be increased. By allowing for adjustment of the length of the one or more straps **2106**, the hand grip **2104** may be sized so as to be secured to a user's appendage (e.g., a hand or forearm) regardless of size.

The rotational mechanism **2110** may include a rotating grommet, a ratcheting swivel or pivot, a ball and socket mechanism, a temporary adhesive, a releasable latch, a clip, one or more buttons, a suction cup, and/or one or more straps allowing for rotational securement of the hand grip **2104** to the case **2102**. The inside of the strap **2106** and/or the rotational mechanism **2110** may be lined at least in part with a pad and/or soft material (e.g., microfiber) to provide comfortable use. In certain embodiments, the rotational mechanism **2110** may be a circular shape, as illustrated, to comfortably con-

form to the palm of a user's hand. In other embodiments, the rotational mechanism 2110 may comprise any suitable and/or ergonomic shape.

When a user is wearing the rotatable holder 2100 by securing the hand grip 2104 to an appendage, the user may change the viewing orientation of the PED 102 disposed in the case 2102 by rotating the case 2102 around the rotational mechanism 2110 while securing the relative position of the hand grip 2104 in a fixed position. For example, a user may orient the rotational mechanism 2110 such that the PED 102 is viewed in a portrait orientation, as illustrated in FIG. 85. By applying rotational force to the PED 102 and/or the case 2102, the case 2102 may be rotated around the rotational mechanism 2110 and viewed in a different orientation including, for example, a landscape orientation. In certain embodiments, the rotational mechanism 2110 may be configured to effectively snap into one or more predetermined orientations including, for example, a portrait orientation and/or a landscape orientation.

In some embodiments, the holder 2100 may not include a case 2102 and the hand grip 2104 may be coupled to the PED 102 directly or via a rotation mechanism 2110. In certain embodiments, the hand grip 2104 and/or rotation mechanism 2110 may be coupled to the PED 102 using one or more straps, buckles, clips, adhesives, and/or other mechanical structures integrated into the PED 102 and/or the hand grip 2104 and/or the rotation mechanism 2110.

FIGS. 87-89 illustrate a support 2200 for a PED 102. The support 2200 may include a case 2202 configured to receive, secure, retain, and carry the PED 102, and may include any combination of the various features and embodiments described in any of the cases and/or holders described herein. As illustrated, the case 2202 may be configured to retain the PED 102 by mechanically securing the PED 102 using a compression fit mechanism or the like. In certain embodiments, the PED 102 may be secured within the case 2202 by one or more securement clips 2204 located on an end of the case 2202 configured to receive the PED 102, as illustrated in FIG. 89.

In some embodiments, the case 2202 may define a window allowing a user to view a display 104 of the PED 102. Further, the case 2202 may include one or more areas exposing the PED 102. In certain embodiments, these areas may aid in removing the PED 102 from the case 2202.

The support 2200 may further comprise one or more kickstands 2206 coupled to the case 2202 that may be configured and arranged to prop up the support 2200 in a viewing position. In certain embodiments, the kickstand 2206 may include any combination of the various features and embodiments described in any of the kickstands described herein. For example, the kickstand 2206 may be rotationally coupled to the case 2202 using a rotational mechanism similar to the rotational mechanism 2018 illustrated in FIGS. 82-84. In such embodiments, the viewing orientation (e.g., portrait and/or landscape orientation) of the PED 102 disposed within the support 2200 may be adjusted by rotating the kickstand 2206 relative to the case 2202. Further, the kickstand 2206 may be adjustable similar to the kickstand 2010 illustrated in FIGS. 82-84.

In certain embodiments, the case 2202 may define a storage region 2208 configured to secure and retain (i.e., store) one or more accessories 2210 associated with the PED 102 to the case 2202. In some embodiments, the one or more accessories 2210 may comprise any PED 102 interface (e.g., a keyboard, a mouse, headphones, and the like) or accessory (e.g., memory devices, cleaning solution, and the like). In certain embodiments, the one or more accessories 2210 may be

secured and retained within the storage region 2208 mechanically using a compression fit mechanism or the like. In certain other embodiments, the one or more accessories may be secured within the storage region 2208 using one or more releasable clips, straps, or other locking features that allow for the accessories 2210 to be selectively locked into the storage region 2208 and selectively released from the storage region 2208.

FIGS. 90-91 illustrates a rotatable case 2300 for a PED 102 oriented in a landscape configuration. In certain embodiments, the rotatable case 2300 may include a holder (not shown) configured to receive, secure, retain, and carry the PED 102, and may include any combination of the various features and embodiments described in any of the cases and/or holders described herein. In other embodiments, as illustrated, the rotatable case 2300 may couple directly to the PED 102.

The rotatable case 2300 may include one or more horizontal supports 2302 extending from a rotational hub 2304 and coupled to an outer edge of the PED 102 via horizontal support clips 2306. In some embodiments, the horizontal support clips 2306 may be coupled to the outer edge of the PED 102 using a compression fit. In alternative embodiments, the horizontal support clips 2306 may be secured to the outer edge of the PED 102 using releasable clips, straps, or any other selectively locking mechanism. In certain embodiments, the length of the horizontal supports 2302 may be adjusted so that the horizontal support clips 2306 fit securely around the outer edge of the PED 102. In this manner, the horizontal supports 2302 may be adjusted to secure PEDs 102 having varied dimensions.

In certain embodiments, the rotational hub 2304 may include a rotational mechanism configured to allow the horizontal supports 2302 to rotate relative to one or more vertical supports 2308. The rotational mechanism may include a rotating grommet, a ratcheting swivel or pivot, a ball and socket mechanism, a temporary adhesive, a releasable latch, a clip, one or more buttons, a suction cup, and/or one or more straps allowing for rotational securement of the horizontal supports 2302 to the vertical supports 2308.

The vertical supports 2308 may be coupled to an outer edge of the PED 102 via vertical support clips 2310. In some embodiments, the vertical support clips 2310 may be coupled to the outer edge of the PED 102 using a compression fit. In alternative embodiments, the vertical support clips 2310 may be secured to the outer edge of the PED 102 using releasable clips, straps, or any other selectively locking mechanism. In certain embodiments, the length of the vertical supports 2308 may be adjusted so that the vertical support clips 2310 fit securely around the outer edge of the PED 102. In this manner, the vertical supports 2308 may be adjusted to secure PEDs 102 having varied dimensions.

Each of the horizontal support clips 2306 may be coupled to the ends of PED supports 2312. In certain embodiments, the horizontal support clips 2306 may be rotatably coupled to the ends of PED supports 2312 such that the PED supports 2312 may rotate in one or more directions relative to the horizontal support clips 2306. In this manner, the PED supports 2312 may be utilized to support the PED 102 when the PED 102 is propped up in an upright and/or elevated viewing position. In certain embodiments, the lengths of the PED supports 2312 may be adjustable.

The other ends of the PED supports 2312 may be coupled to hinges 2314 configured to allow the PED supports 2312 to rotate in one or more directions relative to the hinges 2314. The hinges 2314 may be in turn rigidly coupled to a base 2316. During use of the rotatable case 2300, the base 2316

may be placed on a working surface. The PED 102 may be raised and oriented in a viewing position by placing a bottom edge of the PED 102 on a top surface of the base 2316, as illustrated in FIG. 90. In such a configuration, the PED 102 may be supported in part by PED supports 2312 oriented at an appropriate angle relative to the PED 102 and/or base 2316 via the hinges 2314 and/or the horizontal support clips 2306. In some embodiments, the viewing angle of the PED 102 may be adjusted by changing the relative angle of the PED supports 2312 relative to the PED 102 and/or base 2316. In certain embodiments, the PED supports 2312 may be configured to support the PED 102 at one or more predefined viewing angles using a ratcheting or similar mechanism included in the hinges 2314 and/or the horizontal support clips 2306.

In certain embodiments, the bottom edge of the PED 102 may be positioned in one or more channels (not shown) included on the top surface of the base 2316 that may be similar to the channels 116 illustrated in FIGS. 1-2. In other embodiments, the bottom edge of the PED 102 may be rested on a material included on the top surface of the base 2316 designed to prevent the bottom edge of the PED 102 from easily sliding along the surface (e.g., rubber, suede, or the like).

In certain embodiments, when the PED 102 is in an upright and/or elevated position, the orientation of the PED 102 may be adjusted by rotating the vertical supports 2308 coupled to the PED 102 relative to the horizontal supports 2302 about the rotational hub 2304. For example, the vertical supports 2308 may be rotated about the rotational hub 2304 into a position where the vertical supports 2308 are perpendicular to the horizontal supports 2302 which may correspond to a landscape orientation for the PED 102, as illustrated in FIG. 90. Similarly, the vertical supports 2308 may be rotated about the rotational hub 2304 into a position where the vertical supports 2308 are parallel to the horizontal supports 2302 which may correspond to a portrait orientation for the PED 102.

In some embodiments, the base 2316 may include one or more integrated interfaces 2318 configured to interface with the PED 102. For example, as illustrated in FIG. 90, the base 2316 may include a keyboard. In other embodiments, the interfaces 2318 may include a touch pad, a speaker, or any other interface device capable of being integrated into the base 2316.

When the PED 102 is not in use, the rotatable case 2300 may be reconfigured by a user into a stowage configuration, as illustrated in FIG. 91. To reconfigure the rotatable case 2300 in a stowage configuration, the PED 102 may be articulated around the PED supports 2312, hinges 2314, and/or the horizontal support clips 2306 so as to cover the display 104 of the PED 102 with the top surface of the base 2316. In such a configuration, interfaces 2318 disposed on the top surface of the base 2316 may also be protected from external damage. In certain embodiments, reconfiguration of the case 2300 in a stowage configuration may require that the length of the PED supports 2312 be adjusted. In some embodiments, the base 2316 may be secured to the PED 102 in the stowage configuration via a magnetic connection, one or more releasable clips, straps, and/or other locking mechanism allowing for the rotatable case 2300 to be selectively locked into a stowage configuration and selectively release from the stowage configuration.

FIGS. 92-95 illustrate a rotatable case 2400 for a PED 102 including an integrated keyboard 2406. In certain embodiments, the rotatable case 2400 may include a holder (not shown) configured to receive, secure, retain, and carry the PED 102, and may include any combination of the various features and embodiments described in any of the cases and/

or holders described herein. In other embodiments, as illustrated, the rotatable case 2400 may couple directly to the PED 102.

The rotatable case 2400 may include a holder 2402 extending from a rotational hub 2408 and coupled to the outer edges of the PED 102. In some embodiments, the holder 2402 may include clips coupled to the outer edge of the PED 102 using a compression fit. In alternative embodiments, the holder 2402 may be secured to the outer edge of the PED 102 using releasable clips, straps, or any other selectively locking mechanism. In certain embodiments, the length of the holder 2402 may be adjusted so that the holder 2402 fits securely around the outer edge of the PED 102. In this manner, the holder 2402 may be adjusted to secure PEDs 102 having varied dimensions.

In certain embodiments, the rotational hub 2408 may include a rotational mechanism configured to allow the holder 2402 to rotate relative to a vertical support 2404. The rotational mechanism may include a rotating grommet, a ratcheting swivel or pivot, a ball and socket mechanism, a temporary adhesive, a releasable latch, a clip, one or more buttons, a suction cup, and/or one or more straps allowing for rotational securement of the holder 2402 to the vertical support 2404. In certain embodiments, the vertical support 2404 may be configured to support the PED 102 in a substantially upright and/or elevated position allowing for viewing of the display 104. In some embodiments, the rotational hub 2408 may snap into certain specific rotational orientations (e.g., portrait orientation, as illustrated in FIG. 92, and/or landscape orientation, as illustrated in FIG. 93) and require rotational force to move to a different specific orientation. In alternative embodiments, the rotational hub 2408 may not snap into specific orientations but may allow for rotational articulation in any number of orientations. Further, in certain embodiments, the vertical support 2404 may be coupled to the holder 2402 via a non-rotatable connection including, for example, a fixed and/or hinged mechanism.

The vertical support 2404 may be configured to allow for its length to be adjusted using a sliding track or similar adjustable mechanism. In certain embodiments, the length of the vertical support 2404 may be configured to be adjusted to one or more predetermined positions via a selective locking mechanism or the like. In other embodiments, the vertical support 2404 may have a fixed length.

The vertical support 2404 may be coupled to a base 2410 via a hinge 2412 allowing the vertical support 2404 to rotate relative to the base 2410 in one or more directions. In certain embodiments, by varying the orientation of the vertical support 2404 relative to the base 2410 via the hinge 2412, a viewing angle of the PED 102 disposed in the holder 2402 may be adjusted.

In certain embodiments, the base 2410 may include one or more stabilizing supports 2414 configured to extend outward from the base 2410 on one or more sides and/or in one or more directions. In certain embodiments, the stabilizing supports 2414 may increase the surface area of the base 2410 on a working surface, thereby increasing the stability of the rotational case 2400 when in use. In some embodiments, the stabilizing supports 2414 may be slid along a track or similar mechanism into the base 2410 when not in use, as illustrated in FIG. 94, and be slid out of the base 2410 to provide a more stable platform when in use, as illustrated in FIGS. 92-93 and FIG. 95.

In some embodiments, the base 2410 may include one or more integrated interfaces 2406 configured to interface with the PED 102. For example, as illustrated in FIGS. 92-93 and FIG. 95, the base 2410 may include a keyboard 2406. In other

embodiments, the interfaces **2406** may include a touch pad, a speaker, or any other interface device capable of being integrated into the base **2410**.

When the PED **102** is not in use, the rotatable case **2400** may be reconfigured by a user into a stowage configuration, as illustrated in FIG. **94**. To reconfigure the rotatable case **2400** in a stowage configuration, the PED **102** may be articulated around the hinge **2412** so as to cover the display **104** of the PED **102** with the top surface of the base **2410**. In such a configuration, interfaces **2406** disposed on the top surface of the base **2410** may also be protected from external damage. In certain embodiments, reconfiguration of the case **2400** into a stowage configuration may require that the length of the vertical support **2404** be adjusted and/or a particular rotational orientation of the PED **102** be achieved. In some embodiments, the base **2410** may be secured to the PED **102** in the stowage configuration via a magnetic connection, one or more releasable clips, straps, and/or other locking mechanism allowing for the rotatable case **2400** to be selectively locked into a stowage configuration and selectively release from the stowage configuration.

FIGS. **96-99** illustrate a rotatable case **2500** for a PED **102** including an integrated keyboard **2502**. The rotatable case **2500** may include a holder **2504** configured to receive, secure, retain, and carry the PED **102**, and may include any combination of the various features and embodiments described in any of the cases and/or holders described herein. As illustrated, the holder **2504** may be configured to retain the PED **102** by mechanically securing the PED **102** using a compression fit mechanism or the like. In certain embodiments, the holder **2504** may retain the PED **102** by securing one or more corners of the PED **102**.

The holder **2504** may be coupled to a rotational mechanism **2506** which in turn may be coupled to a vertical support **2508** via an upper hinge **2510**. In certain embodiments, the rotational mechanism **2506** may be configured to allow the holder **2504** to rotate relative to the vertical support **2508**. The rotational mechanism **2506** may include a rotating grommet, a rotating hub, a ratcheting swivel or pivot, a ball and socket mechanism, a temporary adhesive, a releasable latch, a clip, one or more buttons, a suction cup, and/or one or more straps allowing for rotational securement of the holder **2504** to the vertical support **2508**. In certain embodiments, the vertical support **2508** may be configured to support the PED **102** in a substantially upright and/or elevated position allowing for viewing of the display **104**. In some embodiments, the rotational mechanism **2506** may snap into certain specific rotational orientations (e.g., portrait orientation, as illustrated in FIG. **98**, and/or landscape orientation, as illustrated in FIG. **96**, and require rotational force to move to a different specific orientation. In alternative embodiments, the rotational mechanism **2506** may not snap into specific orientations but may allow for rotational articulation in any number of orientations. Further, in certain embodiments, the vertical support **2508** may be coupled the holder **2504** via a non-rotatable connection including, for example, a fixed and/or hinged mechanism, and may be connected directly or via the upper hinge **2510**.

The vertical support **2508** may be configured to allow for its length to be adjusted using a sliding track or similar adjustable mechanism. In certain embodiments, the length of the vertical support **2508** may be configured to be adjusted into one or more predetermined positions via a selective locking mechanism or the like. In other embodiments, the vertical support **2508** may have a fixed length.

The vertical support **2508** may be further coupled to a base **2514** via a lower hinge **2512** allowing the vertical support

2508 to rotate relative to the base **2514** in one or more directions. In certain embodiments, by varying the orientation of the vertical support **2508** relative to the base **2514** via the lower hinge **2512** and/or the holder **2504** via the upper hinge **2510**, a viewing angle of the PED **102** disposed in the holder **2404** may be adjusted.

As illustrated, the base **2514** may include one or more integrated interfaces **2502** configured to interface with the PED **102**. For example, as illustrated in FIGS. **96-98**, the base **2514** may include a keyboard. In other embodiments, the interfaces **2502** may include a touch pad, a speaker, or any other interface device capable of being integrated into the base **2514**. In certain embodiments, the interfaces **2502** may be configured to extend outward from the base **2514** on one or more sides and/or in one or more directions. In certain embodiments, by extending outwards, the interfaces **2502** may increase the effective surface area of the base **2514** on a working surface, thereby increasing the stability of the rotational case **2500** when in use. Further, by extending the interfaces **2502** outwards, the effective usable area of the interfaces **2502** may be increased. For example, when the interfaces **2502** include a keyboard, as illustrated in FIGS. **96-98**, extending the keyboard outwards may increase the size of the keyboard. In certain embodiments, the interfaces **2502** may be slid along a track or similar mechanism into the base **2514** when not in use, as illustrated in FIG. **99**, and be slid out of the base **2514** when in use, as illustrated in FIGS. **96-98**.

When the PED **102** is not in use, the rotatable case **2500** may be reconfigured by a user into a stowage configuration, as illustrated in FIG. **99**. To reconfigure the rotatable case **2500** in a stowage configuration, the PED **102** may be articulated around the upper hinge **2510** and the lower hinge **2512** so as to cover the display **104** of the PED **102** with the top surface of the base **2514**. In such a configuration, interfaces **2502** disposed on the top surface of the base **2514** may also be protected from external damage. In certain embodiments, reconfiguration of the case **2500** into a stowage configuration may require that the length of the vertical support **2508** be adjusted and/or a particular rotational orientation of the PED **102** be achieved. In some embodiments, the base **2514** may be secured to the PED **102** in the stowage configuration via a magnetic connection, one or more releasable clips, straps, and/or other locking mechanism allowing for the rotatable case **2500** to be selectively locked into a stowage configuration and selectively release from the stowage configuration.

FIGS. **100-102** illustrates a support **2600** for a PED **102**. As illustrated, the support **2600** may include a holder (not shown) configured to receive, secure, retain, and carry the PED **102**, and may include any combination of the various features and embodiments described in any of the cases and/or holders described herein. In certain embodiments, a rotatable kickstand **2602** may be coupled to the holder and configured to support the holder and PED **102** in an substantially upright and/or elevated position. In other embodiments, as illustrated, the support **2600** may include a rotatable kickstand **2602** coupled directly to the PED **102** one or more straps, buckles, clips, adhesives, and/or any other similar attachment feature.

In certain embodiments, the rotatable kickstand **2602** may incorporate similar features to the kickstand **1908** described above in reference to FIGS. **78-81**. In this manner, the viewing angle of the PED **102** may be adjusted by articulating the rotatable kickstand **2602** in various manners (e.g., changing the relative angle between the kickstand **2602** and the PED **102**, adjusting the length of the kickstand **2602**, and the like). Further, the viewing orientation of the PED **102** may be

adjusted by rotating the relative position of the kickstand **2602** relative to the PED **102** using a rotational mechanism.

The support **2600** may further include a cover **2604** which in some embodiments, may include one or more integrated interfaces **2606** configured to interface with the PED **102**. For example, as illustrated in FIGS. **100-101**, the cover **2604** may include a keyboard. In other embodiments, the interfaces **2606** may include a touch pad, a speaker, or any other interface device capable of being integrated into the cover **2604**.

When the PED **102** is not in use, the support **2600** may be reconfigured by a user into a stowage configuration, as illustrated in FIG. **102**. To reconfigure the support **2600** in a stowage configuration, the cover **2604** may be secured over a side of the PED **102** so as to cover the display **104** of the PED **102** with the cover **2604** and protect it from external damage. In such a configuration, interfaces **2606** disposed on an inner surface of the cover **2604** may also be protected from external damage. In some embodiments, the cover **2604** may be secured to the PED **102** in the stowage configuration via a magnetic connection, one or more releasable clips, straps, and/or other locking mechanism allowing for the cover **2604** to be selectively locked into a stowage configuration and selectively release from the stowage configuration.

FIG. **103** illustrates an interaction between a support panel **2708** of a rotatable case **2700** and a securing panel **2702** via a selectively detachable rotational mechanism **2716**, **2718**. In certain embodiments, the rotatable case **2700** may include any combination of the various features and embodiments illustrated and described in reference to the rotatable case **800** of FIGS. **22-32**. As illustrated, the rotatable case **2700** may include a securing panel **2702** configured to receive, secure, retain, and carry a PED, and may include any combination of the various features and embodiments described in any of the cases and/or holders described herein.

The rotatable case **2700** may include a base **2706** with one or more support channels **2710** and a supporting panel **2708** comprising a lower portion **2712** and a pivot flat **2714**. The selectively detachable rotational mechanism **2716**, **2718** may include a rear portion **2716** coupled to the supporting panel **808** and a front portion **2718** coupled to the securing panel **2702**, which may include one or more access ports **2704**. In certain embodiments, the rear portion **2716** may be coupled to the pivot flat **2714** of the supporting panel **2708**.

According to various embodiments, the front portion **2718** of the selectively detachable rotational mechanism **2716**, **2718** may be mated with the rear portion **2716** of the selectively detachable rotational mechanism **2716**, **2718** in order to rotatably secure the securing panel **2702** to the pivot flap **2714** and/or supporting panel **2708**. In this manner, the securing panel **2702** may be free to rotate 360 degrees relative to the supporting panel **2708** about the selectively detachable rotational mechanism **2716**, **2718**.

In certain embodiments, the front portion **2718** and the rear portion **2716** of the grommet may be joined together during manufacturing or assembly and are not configured to be selectively separated by a user. Alternatively, a user may selectively separate the front portion **2718** from the rear portion **2716** in order to remove the securing panel **2702** from the pivot flap **2714**, as illustrated in FIG. **103**. In other embodiments, the front portion **2718** and the rear portion **2716** of the grommet are inseparable and the grommet may be selectively detachable from the pivot flap **2714** and/or the securing panel **2702**.

FIG. **104** illustrates an interaction of a selectively detachable rotational mechanism **2716**, **2718** and a securing panel **2702** of a rotatable case **2700** for a PED (not shown). Particularly, FIG. **104** illustrates the securing panel **2702** of FIG. **103**

mounted on a surface **2720** which may, as shown, be a back of a car seat. In alternative embodiments, the surface **2720** may be refrigerator door, a wall, a door, a desk, a window, and/or any other appropriate surface.

To mount the securing panel **2702** on the surface **2720**, the rear portion **2716** of the rotational grommet may be mounted to the surface **2720**, and the front portion **2718** may be secured to the rear portion **2716**, thereby rotationally securing the securing panel **2702** to the surface **2720**. In certain embodiments, the rear portion **2716** may be mounted to the surface **2720** using, for example, an adhesive, hook and loop mechanisms, buttons, one or more zippers, and/or clamps. Further, in some embodiments, the rear portion **2716** may be mounted to the surface **2720** using a mechanism allowing for rotation of the rear portion **2716** in one or more directions relative to the surface **2720** such as, for example, a hinge, a ball and socket joint, and the like. In certain embodiments, the mechanism allowing for rotation of the rear portion **2716** in one or more directions may allow a viewing angle of a PED disposed in the securing panel **2702** to be adjusted relative to the surface **2720**.

FIG. **105** illustrates a rotatable case **2800** including a user interface **2820**. As illustrated, the rotatable case **2800** may include a securing panel **2802** configured to receive, secure, retain, and carry the PED (not shown), and may include any combination of the various features and embodiments described in any of the cases and/or holders described herein. According to various embodiments, the rotatable case **2800** may include various access ports (such as **2804** and **2806**) to facilitate interfacing a PED disposed within the rotatable case **2800** with connector plugs, cables, headphones, speakers, and/or power adaptors. In certain embodiments, the rotatable case **2800** may include built-in cords to route power, connectivity, and/or headphone cables from a PED to an external device. Moreover, according to various embodiments, a battery may be built into a panel or pocket of the rotatable case **2800**.

In certain embodiments, the rotatable case **2800** may have the ability to rotate the securing panel **2802** with respect to a supporting panel **2808** and a base panel **2810**. Any of a wide variety of rotatable securing devices may be employed to rotatably secure securing panel **2802** to supporting panel **2808**. For example, bushings, flanged bushings, grommets, rivets, eyelets, plain bearings, bearings, and/or any combination thereof may be employed to rotatably secure the securing panel **2802** to the supporting panel **2808**. For example, as illustrated, a grommet **2812** may be configured to rotatably secure the securing panel **2802** to the supporting panel **2808**. In some embodiments, the grommet **2812** may comprise a ring that may allow a logo to show through the hole in the middle of grommet **2812**. In certain embodiments, one or more interchangeable accessories and/or inserts may "snap" into the hole in the middle of grommet **2812** including, for example, a logo insert, a proximity alarm or other loss prevention accessory, and the like.

The base panel **2812** may be configured with channels or groves **2814** to secure the bottom edge of securing panel **2802** when the securing panel **2802** is in an upright and/or elevated position. According to various alternative embodiments, in place of channels **2814** a frictional surface (e.g., rubberized surface or the like) or frictional contact patches may be utilized to secure the bottom edge of the securing panel **2802** in an upright and/or elevated position.

The supporting panel **2808** may be configured to provide a counterforce to the securing panel **2802** in order to support securing panel **2802** in an upright and/or elevated position. As illustrated, the supporting panel **2808** and the base panel **2810**

41

may comprise a single panel folded or bent at **2816**. According to various embodiments, the relative proportions of the base panel **2810** and the supporting panel **2808** may be adapted for a particular application. Further, in certain embodiments, the rotatable case **2800** may be configured to support a PED at one or more angles relative to the base panel **2810** and in a plurality of orientations, including portrait and landscape.

In certain embodiments, the rotatable case **2800** may be configured in a stowage mode, wherein the base panel **2810** may be oriented so as to cover and protect a display of a PED secured in the securing panel **2802** from external damage. In some embodiments, the base panel **2810** may include one or more integrated interfaces **2820** including, as illustrated in FIG. **105**, a keyboard. In other embodiments, the interfaces **2820** may include a touch pad, a speaker, or any other interface device capable of being integrated into the base **2810**. In certain embodiments, when the rotatable case **2800** is configured in a stowage mode, the securing panel **2802** and/or the PED may cover and protect the interfaces **2820** from external damage.

It will be understood by those having skill in the art that changes may be made to the details of the above-described embodiments without departing from the underlying principles presented herein. For example, the rotating and/or pivoting systems allowing for adjustable viewing orientation disclosed herein may be integrated into a stand, a mount, or any other type of accessory configured to receive a PED. In addition, any suitable combination of various embodiments, or the features thereof, is contemplated. Further, any methods disclosed herein may comprise one or more steps or actions for performing the described method. These method steps and/or actions may be interchanged with one another. In other words, unless a specific order of steps or actions is required for proper operation of the embodiment, the order and/or use of specific steps and/or actions may be modified.

Throughout this specification, any reference to “one embodiment,” “an embodiment,” or “the embodiment” means that a particular feature, structure, or characteristic described in connection with that embodiment is included in at least one embodiment. Thus, the quoted phrases, or variations thereof, as recited throughout this specification are not necessarily all referring to the same embodiment. Similarly, it should be appreciated that in the above description of embodiments, various features are sometimes grouped together in a single embodiment, figure, or description thereof for the purpose of streamlining the disclosure. This method of disclosure, however, is not to be interpreted as reflecting an intention that any claim require more features than those expressly recited in that claim. Rather, inventive aspects lie in a combination of fewer than all features of any single foregoing disclosed embodiment. It will be apparent to those having skill in the art that changes may be made to the details of the above-described embodiments without departing from the underlying principles set forth herein.

What is claimed is:

1. A case for a portable electronic device, the portable electronic device including a back side and a display side, the case comprising:

- a base panel configured to sit on a working surface;
- a support member pivotally coupled to the base panel and configured to support the portable electronic device in an elevated position;
- a rotational mechanism coupled to the support member;
- and
- a holder comprising,
 - a back surface coupled to the rotational mechanism,

42

- a front surface configured to receive the portable electronic device and secure the portable electronic device with the display side exposed,
- a first side extending from the front surface, and
- a second side extending from the front surface,

wherein the support member is configured to pivot the holder to the elevated position wherein the display side is accessible and the rotational mechanism is configured to allow the holder to rotate to a first position wherein the first side rests on the base panel and to rotate to a second position wherein the second side rests on the base panel, and

wherein the support member is configured to pivot the holder to a stowage position wherein the display side is covered by the base panel.

2. The case of claim 1, wherein in the stowage position, the back surface of the holder defines a portion of the exterior of the case and the support member extends along the back surface of the holder.

3. The case of claim 1, wherein the rotational mechanism comprises a rotational grommet.

4. The case of claim 3, wherein the rotational grommet comprises a first portion coupled to the support member and a second portion coupled to the holder.

5. The case of claim 4, wherein the first portion is configured to selectively detach from the second portion.

6. The case of claim 1, wherein the rotational mechanism comprises a ball and socket mechanism.

7. The case of claim 1, wherein the support member comprises a panel.

8. The case of claim 7, wherein the support member, proximate to the pivotal coupling with the base panel, includes a width substantially the same as a width of the base panel.

9. The case of claim 1, wherein the rotational mechanism is configured to hold into one or more predetermined relative rotational orientations of the holder and the support member.

10. The case of claim 9, wherein the base panel includes an interior surface and the front surface of the holder includes a surface area that is substantially the same as a surface area of the interior surface.

11. The case of claim 1, wherein the holder includes an aperture extending through the front and back surfaces and wherein the rotational mechanism is coupled to the holder proximate to the aperture.

12. A case for a portable electronic device, the portable electronic device including a back side and a display side, the case comprising:

- a base panel including an interior surface and an exterior surface, the base panel configured to sit on a working surface;
 - a support member pivotally coupled to the base panel and configured to support the portable electronic device in an elevated position;
 - a rotational mechanism coupled to the support member;
 - and
 - a holder comprising,
 - a back side coupled to the rotational mechanism, and
 - a front side configured to receive the portable electronic device and secure the portable electronic device with the display side exposed,
- wherein the support member is configured to pivot the holder to the elevated position wherein the holder rests on the interior surface of the base panel and the display side is accessible and, in the elevated position, the rotational mechanism is configured to allow the holder to rotate to a first position wherein the holder rests on the

interior surface of the base panel and to rotate to a second position wherein the holder rests on the interior surface of the base panel, and

wherein the support member is configured to pivot the holder to a stowage position wherein the front side of the holder is covered by the interior surface of the base panel.

13. The case of claim **12**, wherein in the stowage position, the exterior surface of the base panel defines a first part of an exterior of the case and the back side of the holder defines a second part of the exterior of the case.

14. The case of claim **13**, wherein in the stowage position, the support member extends along the back side of the holder.

15. The case of claim **12**, wherein the rotational mechanism comprises a rotational grommet.

16. The case of claim **15**, wherein the rotational grommet comprises a first portion coupled to the support member and a second portion coupled to the holder.

17. The case of claim **12**, wherein the support member comprises a panel.

18. The case of claim **17**, wherein the support member, proximate to the pivotal coupling with the base panel, includes a width substantially the same as a width of the base panel.

19. The case of claim **12**, wherein the front side of the holder includes a surface area that is substantially the same as a surface area of the interior surface of the base panel.

20. The case of claim **12**, wherein the holder includes an aperture extending through the front and back sides and wherein the rotational mechanism is coupled to the holder proximate to the aperture.

* * * * *