

(19) World Intellectual Property  
Organization  
International Bureau



(43) International Publication Date  
16 December 2004 (16.12.2004)

PCT

(10) International Publication Number  
WO 2004/109097 A1

(51) International Patent Classification<sup>7</sup>: F03B 17/06,  
F03D 3/02, 3/06, 9/00

(21) International Application Number:  
PCT/CA2003/002034

(22) International Filing Date:  
31 December 2003 (31.12.2003)

(25) Filing Language: English

(26) Publication Language: English

(30) Priority Data:  
2,432,458 6 June 2003 (06.06.2003) CA

(71) Applicant and

(72) Inventor: HENKENHAF, Willi [CA/CA]; 48602 30th  
Sideroad, RR # 1, Shelbourne, Ontario L0N 1S5 (CA).

(74) Agent: CLARKE, Gordon, S.; Barrister & Solicitor, 180  
Bartlett Blvd., Collingwood, Ontario L9Y 5C9 (CA).

(81) Designated States (*national*): AE, AG, AL, AM, AT, AU,  
AZ, BA, BB, BG, BR, BY, BZ, CA, CH, CN, CO, CR, CU,  
CZ, DE, DK, DM, DZ, EC, EE, EG, ES, FI, GB, GD, GE,  
GH, GM, HR, HU, ID, IL, IN, IS, JP, KE, KG, KP, KR,  
KZ, LC, LK, LR, LS, LT, LU, LV, MA, MD, MG, MK,  
MN, MW, MX, MZ, NI, NO, NZ, OM, PG, PH, PL, PT,  
RO, RU, SC, SD, SE, SG, SK, SL, SY, TJ, TM, TN, TR,  
TT, TZ, UA, UG, US, UZ, VC, VN, YU, ZA, ZM, ZW.

(84) Designated States (*regional*): ARIPO patent (BW, GH,  
GM, KE, LS, MW, MZ, SD, SL, SZ, TZ, UG, ZM, ZW),  
Eurasian patent (AM, AZ, BY, KG, KZ, MD, RU, TJ, TM),  
European patent (AT, BE, BG, CH, CY, CZ, DE, DK, EE,  
ES, FI, FR, GB, GR, HU, IE, IT, LU, MC, NL, PT, RO, SE,  
SI, SK, TR), OAPI patent (BF, BJ, CF, CG, CI, CM, GA,  
GN, GQ, GW, ML, MR, NE, SN, TD, TG).

**Declarations under Rule 4.17:**

— as to the identity of the inventor (Rule 4.17(i)) for all des-  
ignations

[Continued on next page]

(54) Title: FLUID ACTIVATED WHEEL/GENERATOR PAIR

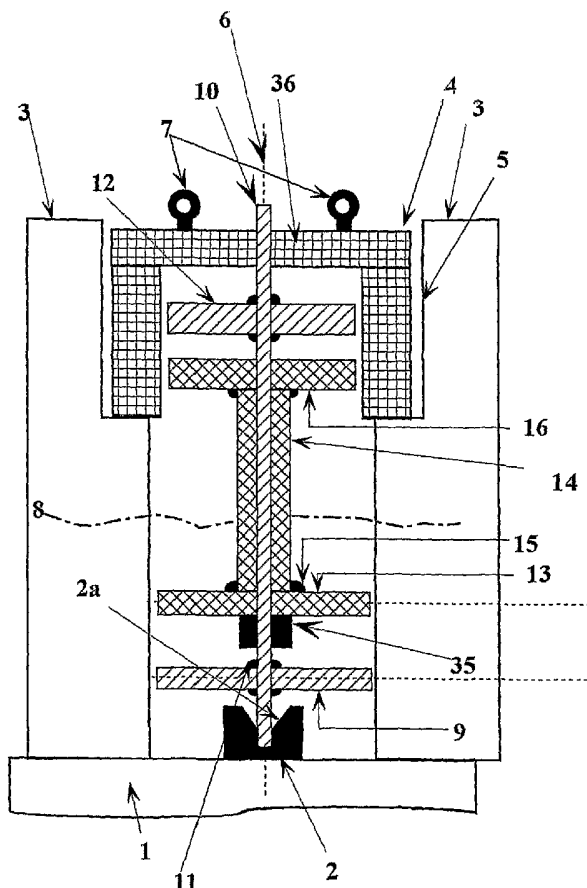

(57) Abstract: The invention provides a pair of co-rotating  
fluid powered wheel and generator pairs each rotating  
about a single vertical axis. Each wheel/generator is  
mounted on a respective axle one of which is solid and  
the other tubular. Separation of fluid flow into 2  
streams engages the wheels for rotation in opposite  
directions. Folding paddles collapse and extend to  
engage the moving fluid.

WO 2004/109097 A1



- as to the applicant's entitlement to claim the priority of the earlier application (Rule 4.17(iii)) for all designations
- of inventorship (Rule 4.17(iv)) for US only

For two-letter codes and other abbreviations, refer to the "Guidance Notes on Codes and Abbreviations" appearing at the beginning of each regular issue of the PCT Gazette.

**Published:**

- with international search report

## FLUID ACTIVATED WHEEL/GENERATOR PAIR

## DESCRIPTION

## 5 BACKGROUND

Power generators have been known for many years and are often combined in multiple units to increase available power. Such generators are activated by moving wind or water and utilize the kinetic energy of the moving fluid to provide mechanical energy usually in the form of rotation of mechanical components. The moving fluid interacts with a series of paddles which rotate under the force of the movement. When connected to an electrical generator electric power is produced. Wheels may have fixed or movable paddles each of which interact with a moving fluid such as water or air in turn to provide the source of work. Movable paddles typically enhance the work available from the moving fluid stream by confining water and wheel interaction for desirable rotation.

## PRESENT INVENTION

The present invention seeks to overcome disadvantages of multiple unit fluid and water wheels as known in the prior art in a manner both economical and susceptible to long service life.

It is a further object of the invention to provide ready movability of the wheel assembly and its major components and maintenance both on and off site, particularly off-site where maintenance may be economically conducted while substituted components continue the necessary functions.

It is a further object of the invention to provide relative high efficiency in resultant power generation and lower maintenance costs in an environmentally friendly manner with provision for passage of life and fluid-borne debris.

- 30 The present invention provides a balanced counter-rotating pair of fluid activated wheel/generator pairs mounted for co-axial rotation.

#### DRAWINGS

Figure 1 shows a cross-section of the preferred embodiment of the invention as applied to a moving water stream.

- 35 Figure 2 shows a cross-section of the 2-part moving water stream as it is presented to the Left Turning and Right Turning wheels of Figure 1.

Figures 3a and 3b show plan views of the Left Turning and Right Turning wheels.

- 40 Figure 4 shows a plan view of the preferred embodiment including a funnel entry.

Figure 5 shows a cross-section along line A-A of Figure 4.

Figure 6 shows a cross-section of a typical water wheel of the present invention with paddles extended.

- 45 Figure 7 shows an alternative preferred embodiment of the invention adapted for use as a wind driven wheel/generator pair.

#### THE PREFERRED EMBODIMENTS

The preferred embodiment shown in Figure 1 provides a base 1 typically constructed of concrete or like material resting on the bed of the body of

50 moving water. The moving water has a nominal water level as at 8 in Figure 1. Preferably base 1 includes a main support bearing block 2 and suitable centering and alignment means 2a.

Tubular casement 3 is lowered on to the base 1 and axially aligned with block 2.

55 Preferably, wheel/generator combination 4 is a single unit lowered into place co-axially with casement 3 so as to rest on bearing block 2 and with main co-axis 6 being generally vertical. Lifting eyes 7 are provided in wheel/generator 4 for ease of installation and removal. Alternatively, wheel/generator 4 may include bearing block 2 as a single unit. In this  
60 configuration, means such as co-operating recesses (not shown) between base 1 and casement 2 provide for self-aligning co-axial installation.

Preferably casement 3 is provided with a recess 5 adapted to both support wheel/generator 4 and maintain co-axis 6 vertical over bearing block 2.

65 Right-turning (RT) water wheel 9 is fixed to solid central axle 10 as by welding or other means as at 11 in Figure 1. Rotational motion of the RT water wheel 9 is transmitted upwards by axle 10 and causes corresponding right turning motion of the right-turning (RT) generator armature 12 and production of electric power.

70 Left-turning (LT) water wheel 13 is fixed to tubular central axle 14 as by welding or other means as at 15 in Figure 1. Rotational motion of the LT water wheel 13 is transmitted upwards by tubular axle 14 and causes corresponding left turning motion of the left-turning (LT) generator armature 16 and production of electric power.

75 Vertical positioning of LT water wheel 13 is maintained by bearing block 35 affixed to solid axle 10.

Preferably solid axle 10 is also supported for vertical alignment by centering support 36.

Axles 14 and 10 are co-axial about co-axis 6 and provide that both the RT and the LT armatures 12 and 16 respectively provide work energy  
80 simultaneously to the generator portion 4.

As shown schematically in Figure 2 the casement 3 is provided with upper and lower water channels 17 and 18 respectively which individually direct water flow against the LT and RT water wheels 13 and 9 on either side of co-axis 6 for opposite rotation of the water wheels with  
85 a single flow of water.

Figures 3a and 3b show plan views of the preferred embodiment of the invention.

Figure 3a shows the RT (lower) water wheel 9 in plan view and its corresponding water flow 18a. Water flow 18a passes through and  
90 around water wheel 9 to cause rotation of the wheel 9 on vertical axle 10 about co-axis of rotation 6.

Figure 3b shows a plan view of the LT (upper) water wheel 13 and its corresponding water flow 17a. Wheel 13 is rotated counterclockwise by the movement in water flow 17a around tubular axle 14 about co-axis 6.

95 Each of the water wheels is constructed of a central disk 25 and a hub 26. A series of paddles 20 are each mounted to the disk 25 for rotation about a vertical axle 21 from a fully open water-engaging position 22 to a fully collapsed position 23. In the open position 22 the innermost end of paddle 20 abuts hub 26 and engages the corresponding wheel.

100 The LT and RT water wheels 13 and 9 are mirror images of each other in plan view in the preferred embodiment and can be constructed of

essentially the same components for ease of manufacture, assembly and repair. Preferably each wheel has the same number of equally-spaced identical paddles 20 arranged with their forward positions, as at positions  
105 27a and 27b respectively, in vertical alignment.

Preferably forward positions 27 correspond with the corresponding inner edges 28a and 28b of the water flows 17a and 17b respectively.

Significant spacing may be provided between casement inner wall 19 and the extremity of each paddle in either or both of the open and/or closed  
110 position as at 28 and 29 in Figure 3b.

The arrangement of co-axis 6 centrally located with the axles 10 and 14 along with the aligned forward positions 27a and 27b provides for a balanced and reduced stress configuration.

In an alternative preferred embodiment (not shown) the axles 10 and 14  
115 may be geared together for corresponding and opposite rotation throughout service life. Such corresponding rotation would more exactly match and balance the stresses and vibrations associated with opening and closing of collapsing paddles 20 and more uniform development of electrical power.

120 Alternatively, the paddle opening and closing may be guided in association with both the position on the respective wheel and the rotational position of that wheel in the casement 3.

Additionally preferably, casement 3 may be provided with a funnel entry as at 31 in Figure 4. Co-operating converging vertical surfaces 32 and 33,  
125 each in 2 parts, a and b, act to increase the water speed and are adapted to separate water flows into entry streams 17a and 18a.

Figure 5 shows a cross-section of entry 31 taken along line A-A in Figure 4. Surfaces 32a and 33a form a funnel for the upper water flow 17a while surfaces 32b and 33b correspondingly form the lower funnel for water flow 18a. As can be seen water flow 17a is confined and directed onto LT wheel 13 while flow 18a is directed onto RT wheel 9 through channels 17 and 18 respectively.

Figure 6 shows the preferred wheel arrangement in greater detail in connection with RT wheel 9 and with paddles on both sides fully extended so as to abut hub 26 at abutment 24.

The alternative preferred embodiment shown in Figure 7 provides a base 1a typically constructed of concrete or like material from which the preferred embodiment extends generally vertically into the moving fluid, wind.

Preferably base 1a includes a main support bearing block 2 and suitable centering and alignment means 2a and generator portion 4a.

Preferably, wind wheel/generator combination, designated 36a, is a single unit with main co-axis 6a extending vertically from block 2a. Lifting eyes 7a are provided for installation and stabilization as by guy wires 31 and base attachments 32.

Right-turning (RT) wheel 9a is fixed to solid central axle 10a as by welding at 11a in Figure 7.

Rotational motion of the RT wheel 9a is transmitted downwards by axle 1a and causes correspondingly right turning motion of the right-turning generator armature 12a and production of electrical power in known manner.



Left-turning (LT) wind wheel 13a is fixed to tubular control axle 11a as by welding as at 15a in Figure 7. Rotational motion of the LT wheel 13a is also transmitted downwards by tubular axle 14a and causes  
155 corresponding motion of the left-turning (LT) generator armature 16a and production of electrical power.

The vertical position of LT wheel 13a is maintained by bearing block 35a affixed to solid axle 10a.

Axles 14a and 10a are co-axial about co-axis 6a and provide that both the  
160 RT and the LT armatures 12a and 16a respectively provide work energy simultaneously to the generator portion 4a.

A casement (not shown), similar to casement 3 as shown schematically in Figure 2, may be provided with upper and lower fluid or wind channels 17 and 18 respectively which individually direct flow against the LT and  
165 RT wheels 13a and 9a on either side of co-axis 6a for opposite rotation of the wheels with a single flow. Since the forces encountered in a wind situation are different from that with water the wheels 13a and 9a preferably have a greater height and may be made of lighter materials as may the optional casement, not shown. Figures 3a and 3b depict plan  
170 views of this preferred embodiment of the invention as well as that preferred embodiment shown in Figure 1 with suitable adaptation of the reference numbers to include the reference "a" to specifically refer to the Figure 7 fluid embodiment.

Figure 3a depicts the RT (lower) wheel 9a in plan view and its  
175 corresponding flow 18a. Flow 18a passes through and around wheel 9a to cause rotation of the wheel 9a on vertical axle 10a about co-axis of rotation 6a.

Figure 3b depicts a plan view of the LT (upper) wheel 13a and its corresponding flow 17a. Wheel 13a is rotated counterclockwise by the movement in flow 17a around tubular axle 14a also about co-axis 6a.

Each of the wheels is constructed of a central disk, not separately shown in Figure 7 but depicted in Figures 3 through 6, as at 25a and a hub as at 26 in Figures 3. A series of paddles 20 are each mounted to the disk 25 for rotation about a vertical axle 21 from a fully open fluid-engaging position 22 to a fully collapsed position 23. In the open position 22 the innermost end of paddle 20 abuts hub 26 and engages the corresponding wheel.

The LT and RT wheels 13a and 9a are also mirror images of each other in plan view in this preferred embodiment and can be constructed of essentially the same components for ease of manufacture, assembly and repair. Preferably each wheel has the same number of equally-spaced identical paddles 20 arranged with their forward positions, as at positions 27a and 27b respectively, in vertical alignment.

Preferably forward positions 27 correspond with the corresponding inner edges 28a and 28b of the fluid flows 17a and 17b respectively.

Significant spacing may be provided between casement inner wall 19 and the extremity of each paddle in either or both of the open and/or closed position as at 28 and 29 in Figure 3b.

The arrangement of co-axis 6a centrally located with the axles 10 and 14 along with the aligned forward positions 27a and 27b provides for a balanced and reduced stress configuration.

In an alternative preferred embodiment (not shown) the axles 10 and 14 may be geared together for corresponding and opposite rotation throughout service life. Such corresponding rotation would more exactly

205 match and balance the stresses and vibrations associated with opening and closing of collapsing paddles 20 and more uniform development of electrical power.

Alternatively, the paddle opening and closing may be guided in association with both the position on the respective wheel and the  
210 rotational position of that wheel in the casement 3.

Additionally preferably, generator 36a may be provided with funnel-shaped entries such as depicted in Figures 4 and 5 with suitable adaptations of vertical dimensions to reflect the greater vertical size of wheels 9a and 13a.

215 It will be obvious to those skilled in the art that modifications may be made to the embodiments described above without departing from the scope of the present invention.

220

## CLAIMS

What I claim is:

1. A fluid wheel generator comprising:
  - a) A first fluid wheel and generator pair mounted on a first vertical  
5 axle for rotation about a vertical axis,
  - b) A second fluid wheel and generator pair mounted on a second  
vertical axle for co-rotation with said first fluid wheel and generator pair  
about said first vertical axis,
  - c) Said second vertical axle adapted for rotation about said first  
10 vertical axle,
  - d) Said first and second fluid wheels mounted for immersion in a  
stream of moving fluid,
  - e) Said first and second generators mounted in or above said moving  
stream of fluid.
- 15 2. A water wheel generator as claimed in claim 1 wherein each of said  
wheels further comprise a central hub and a plurality of paddles for  
engaging the said stream of moving fluid.
3. A fluid wheel generator as claimed in claim 2 wherein each of said  
paddles is mounted to said central hub for rotation about a paddle vertical  
20 axis from a closed to an open and fluid engaging position.
4. A water wheel generator as claimed in claims 1, 2 or 3 wherein  
said fluid is water.
5. A water wheel generator as claimed in claim 4 wherein said  
generators are both mounted above said moving stream of water.

- 25 6. A wind powered wheel generator as claimed in claims 1, 2 or 3 wherein said fluid is air and said first and second wheel and generator pairs extend generally vertically above said generators.

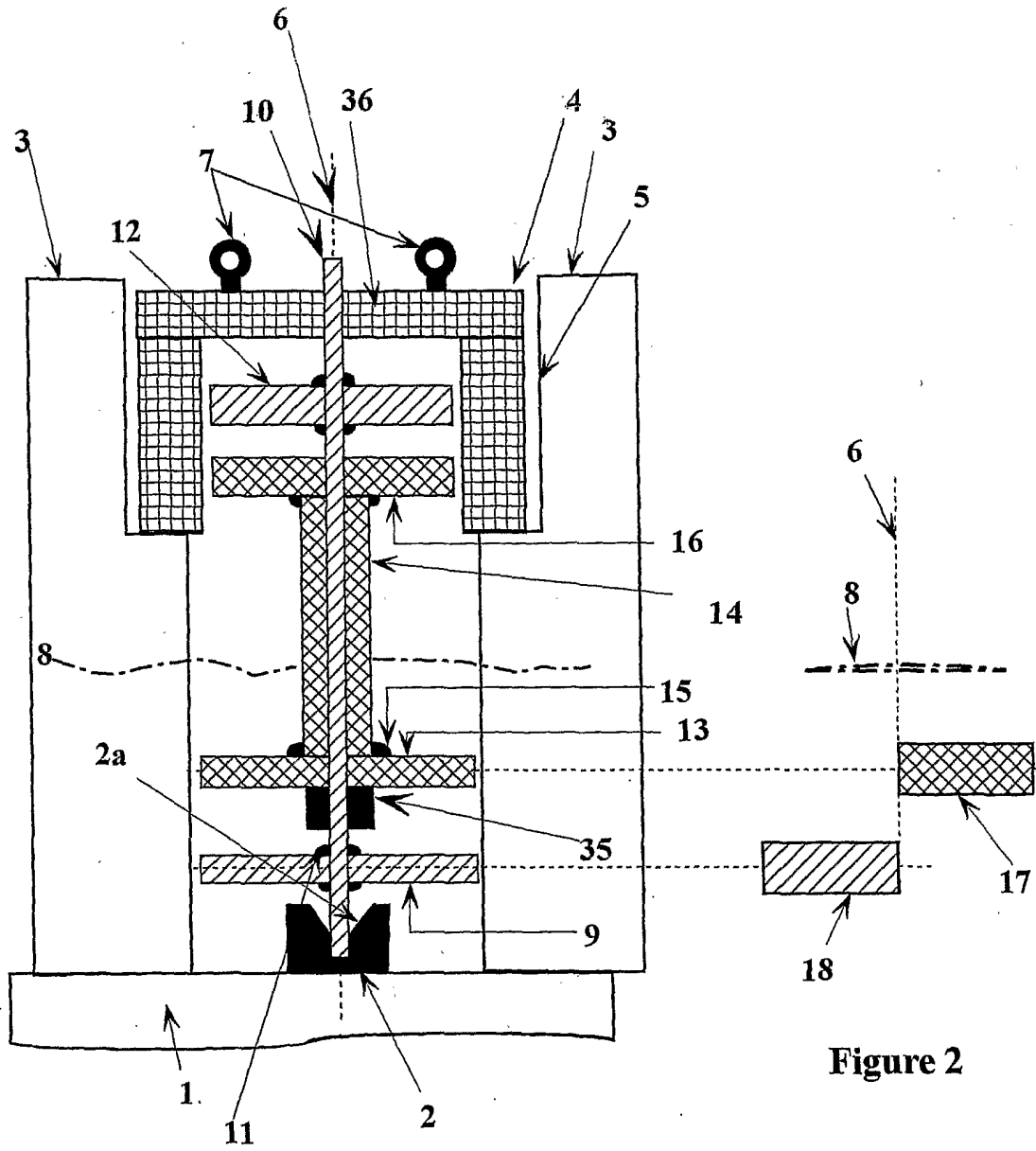

Figure 1

Figure 2

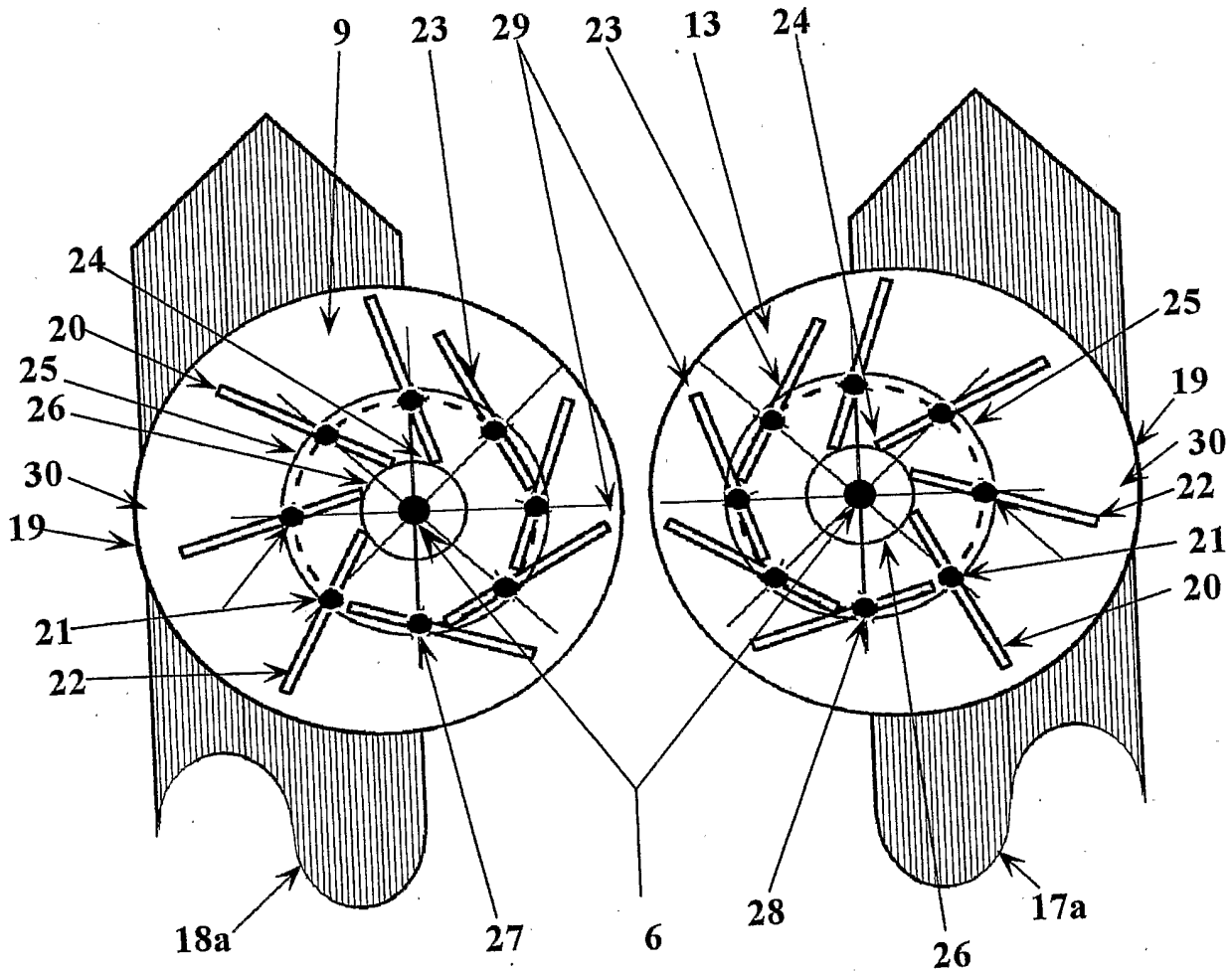

Figure 3a

Figure 3b

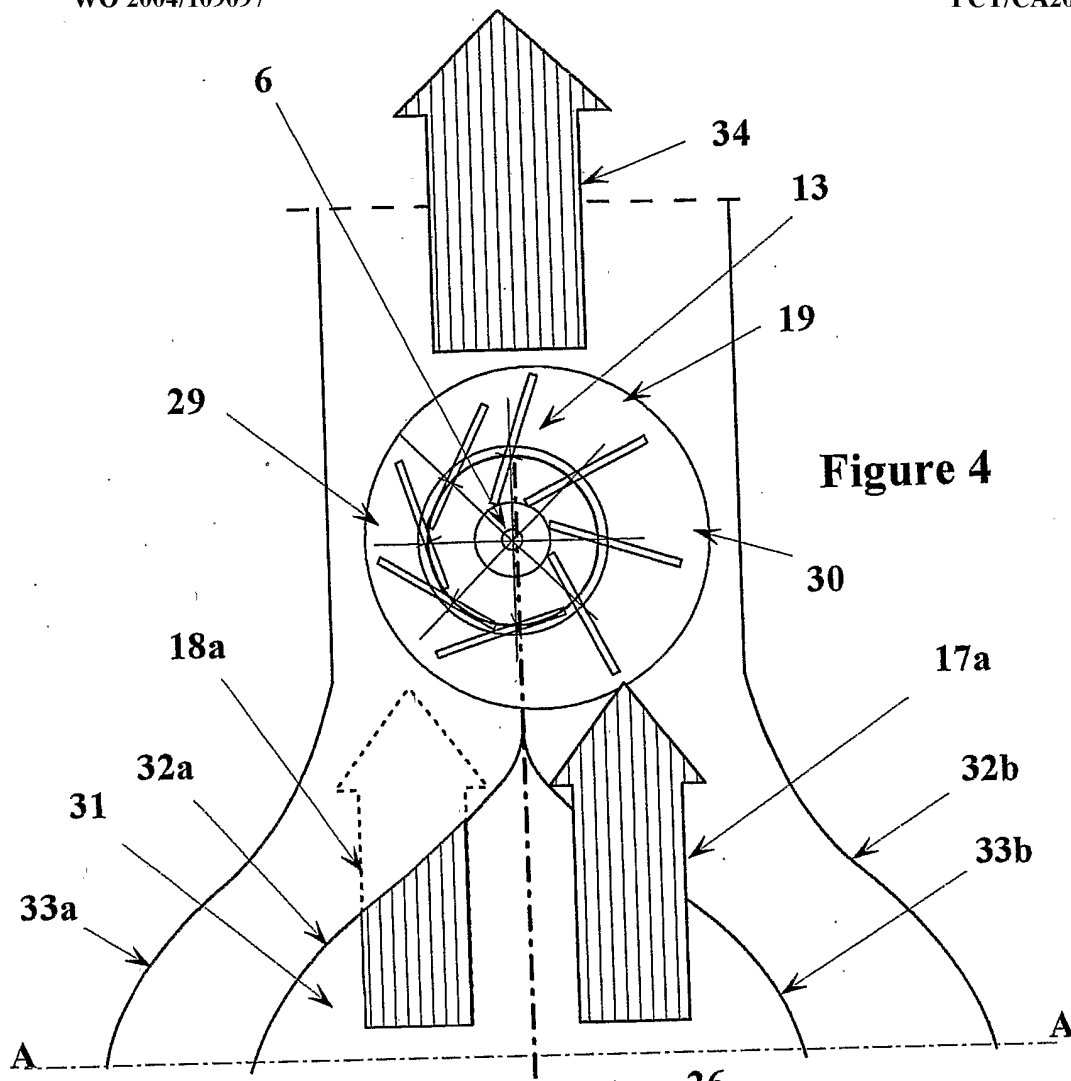

Figure 4

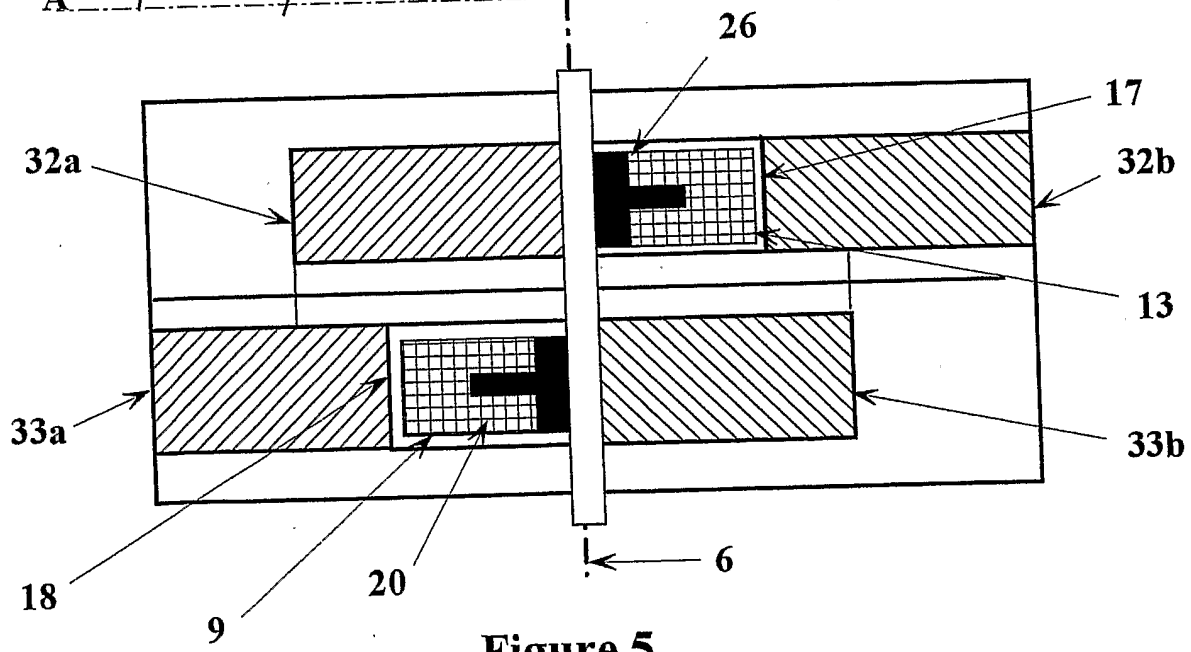
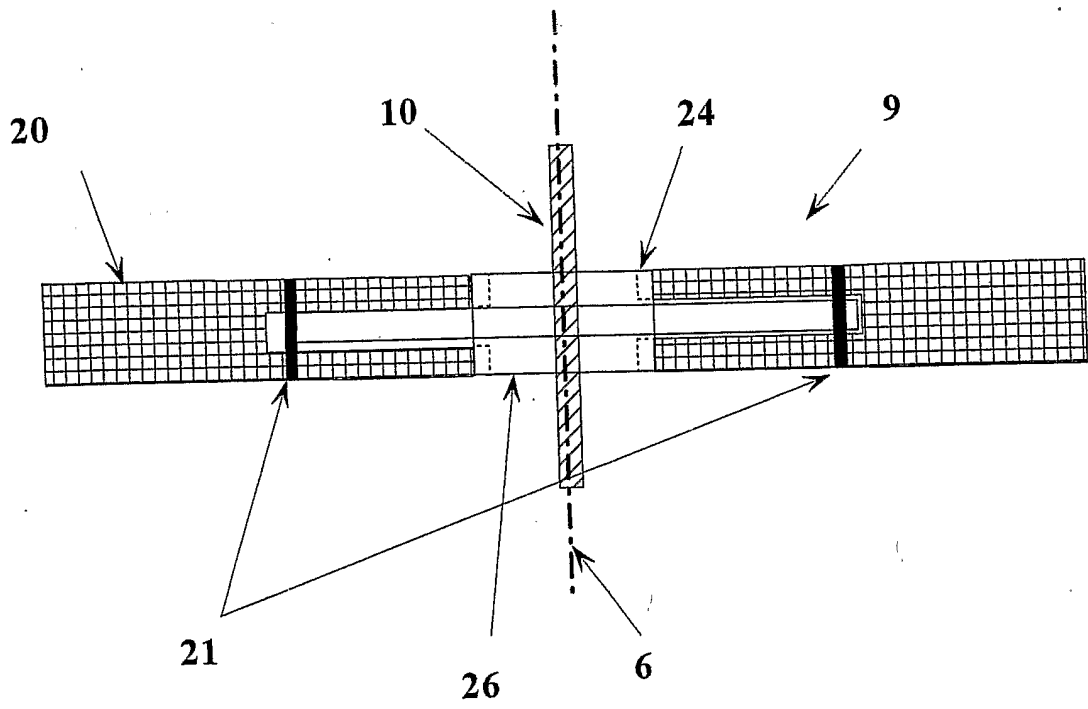

Figure 5



Figure 6



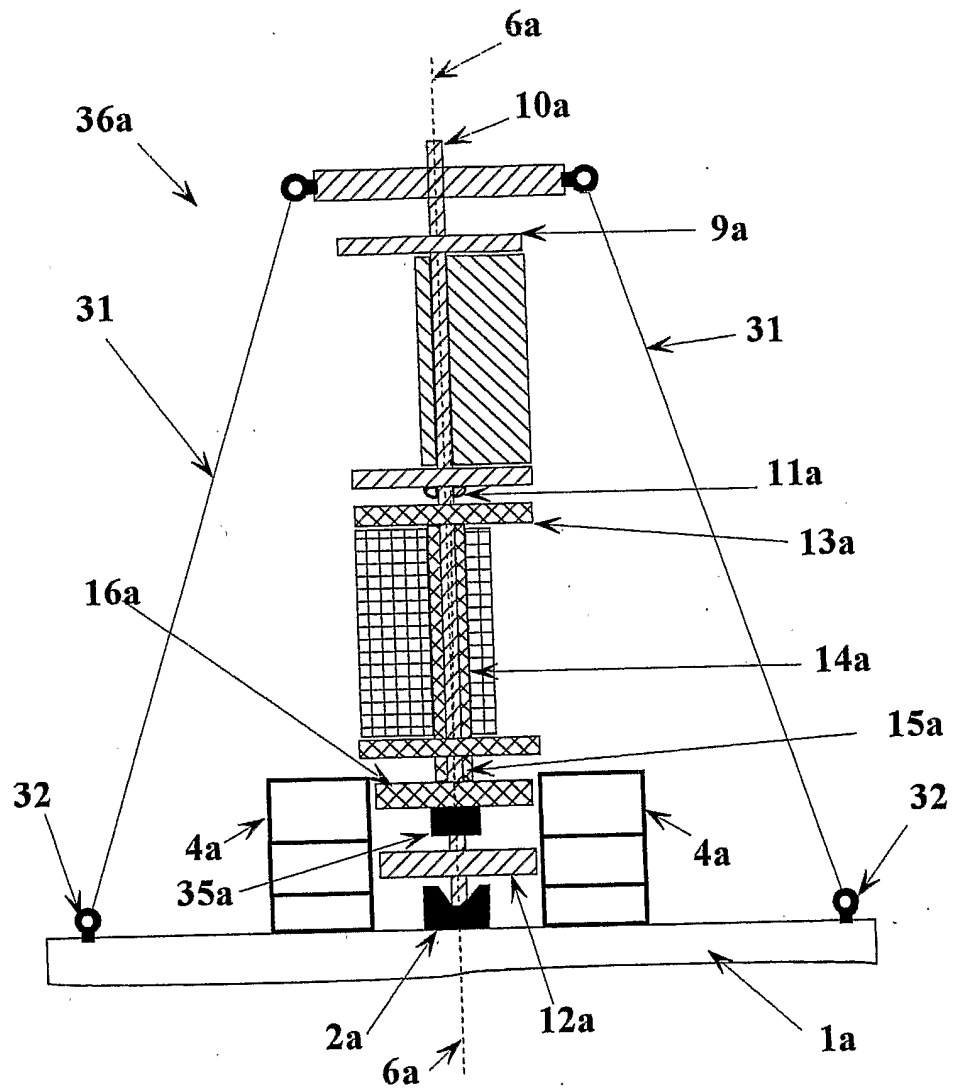

Figure 7

# INTERNATIONAL SEARCH REPORT

International Application No  
PCT/CA 03/02034

<b>A. CLASSIFICATION OF SUBJECT MATTER</b> IPC 7 F03B17/06 F03D3/02 F03D3/06 F03D9/00		
According to International Patent Classification (IPC) or to both national classification and IPC		
<b>B. FIELDS SEARCHED</b>		
Minimum documentation searched (classification system followed by classification symbols) IPC 7 F03B F03D		
Documentation searched other than minimum documentation to the extent that such documents are included in the fields searched		
Electronic data base consulted during the international search (name of data base and, where practical, search terms used)  EPO-Internal		
<b>C. DOCUMENTS CONSIDERED TO BE RELEVANT</b>		
Category °	Citation of document, with indication, where appropriate, of the relevant passages	Relevant to claim No.
A	US 4 057 270 A (LEBOST BARRY ALAN) 8 November 1977 (1977-11-08) abstract column 3, line 22 - column 5, line 43; figures	1-3,6
A	----- WO 00/68567 A (WORMS LOUIS) 16 November 2000 (2000-11-16) page 3, line 1 - page 5, line 8; figures -----	2-5
<input type="checkbox"/> Further documents are listed in the continuation of box C.		
<input checked="" type="checkbox"/> Patent family members are listed in annex.		
° Special categories of cited documents :		
"A" document defining the general state of the art which is not considered to be of particular relevance "E" earlier document but published on or after the international filing date "L" document which may throw doubts on priority claim(s) or which is cited to establish the publication date of another citation or other special reason (as specified) "O" document referring to an oral disclosure, use, exhibition or other means "P" document published prior to the international filing date but later than the priority date claimed	"T" later document published after the international filing date or priority date and not in conflict with the application but cited to understand the principle or theory underlying the invention "X" document of particular relevance; the claimed invention cannot be considered novel or cannot be considered to involve an inventive step when the document is taken alone "Y" document of particular relevance; the claimed invention cannot be considered to involve an inventive step when the document is combined with one or more other such documents, such combination being obvious to a person skilled in the art. "&" document member of the same patent family	
Date of the actual completion of the international search	Date of mailing of the international search report	
23 March 2004	30/03/2004	
Name and mailing address of the ISA European Patent Office, P.B. 5818 Patentlaan 2 NL - 2280 HV Rijswijk Tel. (+31-70) 340-2040, Tx. 31 651 epo nl, Fax: (+31-70) 340-3016	Authorized officer  Criado Jimenez, F	

# INTERNATIONAL SEARCH REPORT

International Application No  
PCT/CA 03/02034

Patent document cited in search report	Publication date	Patent family member(s)	Publication date
US 4057270	A	NONE	
WO 0068567	A	NL 1012037 C2 AU 4627500 A WO 0068567 A1	14-11-2000 21-11-2000 16-11-2000