

P. HOLLER.
Chronometer-Movement.

No. 218,268.

Patented Aug. 5, 1879.

Fig. 1.

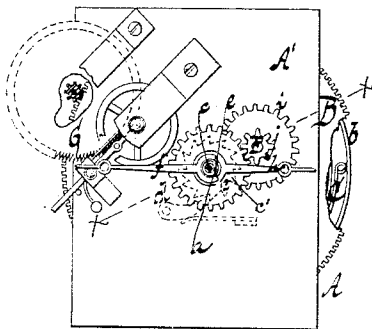
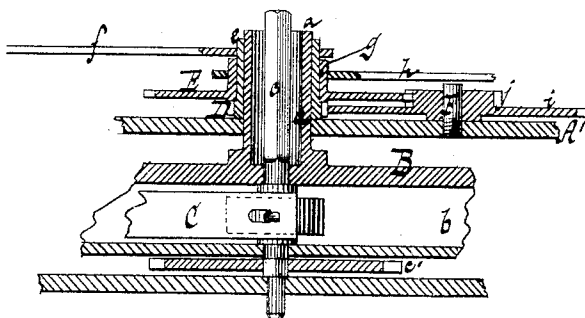

Fig. 2.



Witnesses.

Otto Schufeland
William Miller

Inventor.
Peter Holler.

by

Van Santvoord Stauff
his attorney

UNITED STATES PATENT OFFICE.

PETER HOLLER, OF BROOKLYN, NEW YORK.

IMPROVEMENT IN CHRONOMETER-MOVEMENTS.

Specification forming part of Letters Patent No. **218,268**, dated August 5, 1879; application filed May 7, 1879.

To all whom it may concern:

Be it known that I, PETER HOLLER, of Brooklyn, in the county of Kings and State of New York, have invented a new and useful Improvement in Chronometer-Movements, which improvement is fully set forth in the following specification, reference being had to the accompanying drawings, in which—

Figure 1 represents a front view of a chronometer-movement embodying my invention. Fig. 2 is a cross-section thereof, taken in the plane of the line *x x*, Fig. 1.

Similar letters indicate corresponding parts.

My invention relates to chrouometer-movements, including those of clocks, watches, and the like, its object being to simplify the construction and operation of such movements; and it consists in the combination, in a clock or watch movement, of a wheel secured to the drum, which is operated by the motor, and provided with a hollow arbor surrounding the winding-arbor, upon which said drum is mounted, an escapement operated directly by said wheel, and a minute-hand mounted on the hollow arbor of said wheel; further, in the combination, with the above, of suitable dial-work or minute-wheel works and an hour-hand, all arranged to give the hour-hand its proper rate of speed with respect to the minute-hand.

In the drawings, the letter *A* designates an ordinary frame supporting the parts of my movement, and *B* is a wheel secured to a drum, *b*, to which motion is given by means of a spring, *C*, which is arranged within the drum, one end of the spring being fastened to the drum, and the other end to a winding-post, *c*, which passes through the arbor *a* of the wheel, and with which are combined the usual ratchet-wheel and pawl, as at *e' d*.

The wheel-arbor *a* is made hollow, in order to allow the winding-post *c* to pass through it, and it projects from the wheel through and beyond the face-plate *A'* of the frame-work.

The letter *f* designates the minute-hand of the chronometer. This hand is secured upon the arbor *a* by means of a sleeve, *e*, carrying a pinion, *D*, which is geared by means of wheels *i j* with a wheel, *E*, secured to a sleeve, *g*, which carries the hour-hand *h*, so that mo-

tion may be transmitted from the minute-hand to the hour-hand. The wheels *i j* are mounted on a shaft, *F*, and, in connection with the wheel *E*, pinion *D*, and the sleeves, form the dial-work.

The wheel *B* is provided with cogs, and it is geared directly with the arbor of an escapement-wheel, *G*, the latter being combined with suitable devices to form an escapement. The object of this arrangement is to save the gearing heretofore required to connect the wheel answering to the wheel *B* with an escapement-wheel. The number of teeth on this wheel *B* is so proportioned relatively to those of the escapement-wheel *G* that the wheel *B* makes one revolution an hour, and since the minute-hand *f* is attached to the shaft of this wheel the same performs a like motion.

What I claim as new, and desire to secure by Letters Patent, is—

1. The combination, in a clock or watch movement, of a wheel secured concentrically to the drum, which is operated by the motor, and provided with a hollow arbor surrounding the winding-arbor, upon which said drum is mounted, an escapement operated directly by said wheel, and a minute-hand mounted upon the hollow arbor of said wheel, substantially as described.

2. The combination of the wheel *B*, forming a part of the drum *b*, and provided with the hollow arbor *a*, having a bearing in the front plate, *A'*, of the winding-arbor *c*, extending through said hollow arbor, and having attached to it one end of the spring *C*, the other end of which is secured to the drum, said winding-arbor having one bearing in the center of said wheel and another in a stationary back plate, a ratchet-wheel fixed upon said winding-arbor, a suitable pawl to hold said ratchet-wheel, and a hand mounted upon said hollow arbor, substantially as described.

In testimony that I claim the foregoing I have hereunto set my hand and seal this 6th day of May, 1879.

PETER HOLLER. [L. s.]

Witnesses:

E. F. KASTENHUBER,
CHAS. WAHLERS.