



(12) **United States Design Patent**
Taghizadeh et al.

(10) **Patent No.:** **US D716,601 S**
(45) **Date of Patent:** **** Nov. 4, 2014**

- (54) **TISSUE MINCING TOOL**
- (71) Applicant: **Auxocell Laboratories, Inc.**,
Cambridge, MA (US)
- (72) Inventors: **Rouzbeh R. Taghizadeh**, Cambridge,
MA (US); **Matthew C. Carpenter**,
North Attleboro, MA (US); **David J.**
Copeland, Minnetonka, MN (US);
Matthew J. Perry, East Greenwich, RI
(US); **Paul A. Puniello**, Bristol, RI (US)
- (73) Assignee: **Auxocell Laboratories, Inc.**,
Cambridge, MA (US)
- (**) Term: **14 Years**
- (21) Appl. No.: **29/488,456**
- (22) Filed: **Apr. 18, 2014**
- (51) **LOC (10) Cl.** **31-00**
- (52) **U.S. Cl.**
USPC **D7/372**
- (58) **Field of Classification Search**
CPC A01F 2015/07; A01F 2015/077; A01F
2015/0775; A23N 1/00; A23N 1/02; A47J
19/00; A47J 19/005; A47J 19/02; A47J
19/025; A47J 19/04; A47J 19/06; A47J 42/32;
A47J 42/34; A47J 42/36; A47J 43/044;
A47J 43/25; A47J 43/255; B01F 7/26;
B01F 7/28; B01F 11/0082; B01F 13/04;
B02C 13/00; B02C 13/02; B02C 13/10;
B02C 18/06; B02C 18/26; B02C 18/30;
B02C 18/302; B02C 18/304; B02C 18/305;
B02C 25/00; B02C 2002/00; B02C 2013/00;
B02C 2013/14; B02C 2013/145; B02C
2013/18; B02C 2013/1807; B02C 2013/1857;
B02C 2013/1864; B30B 9/00; B30B 9/16;
B30B 9/18; B30B 9/20; B30B 9/26; B30B
9/205; B30B 9/207

USPC D7/372, 376–386, 665–666, 669,
D7/678–679, 693–694; 99/495, 501–513;
100/94–95, 98 R, 144, 147; 241/33–34,
241/36–37.5, 82.1, 82.4–82.5, 92–93, 100,
241/168–169, 273.1; 366/197, 204, 206,
366/251, 258, 341, 347
See application file for complete search history.

(56) **References Cited**

U.S. PATENT DOCUMENTS

2,695,643 A * 11/1954 Aberer 241/92
D215,390 S * 9/1969 McGee D7/383

(Continued)

Primary Examiner — Ricky Pham

(74) *Attorney, Agent, or Firm* — Goodwin Procter LLP

(57) **CLAIM**

The ornamental design for a tissue mincing tool, as shown and described.

DESCRIPTION

FIG. 1 is a top, front perspective view of a tissue mincing tool; FIG. 2 is a bottom, rear perspective view of the tissue mincing tool; FIG. 3 is a front view of the tissue mincing tool; FIG. 4 is a rear view of the tissue mincing tool; FIG. 5 is a right side view of the tissue mincing tool; FIG. 6 is a left side view of the tissue mincing tool; FIG. 7 is a top view of the tissue mincing tool; FIG. 8 is a bottom view of the tissue mincing tool; FIG. 9 is an exploded top, front perspective view of the tissue mincing tool; and, FIG. 10 is an exploded bottom, rear perspective view of the tissue mincing tool.

1 Claim, 7 Drawing Sheets

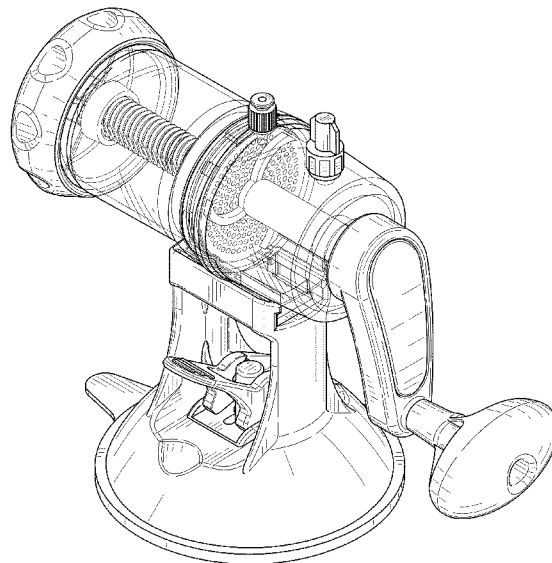

(56)

References Cited

U.S. PATENT DOCUMENTS

D233,123 S *	10/1974	Rigamonti	D7/372	D531,850 S *	11/2006	Wong	D7/372
D424,889 S *	5/2000	Yip	D7/679	7,207,510 B2 *	4/2007	Wong	241/82.1
D484,738 S *	1/2004	Wong	D7/372	D680,390 S *	4/2013	Dichraff et al.	D7/693
D507,455 S *	7/2005	Bertulis	D7/376	D694,074 S *	11/2013	Wong	D7/678
				2006/0243837 A1 *	11/2006	Wong	241/82.1
				2007/0277682 A1 *	12/2007	Wong	99/495

* cited by examiner

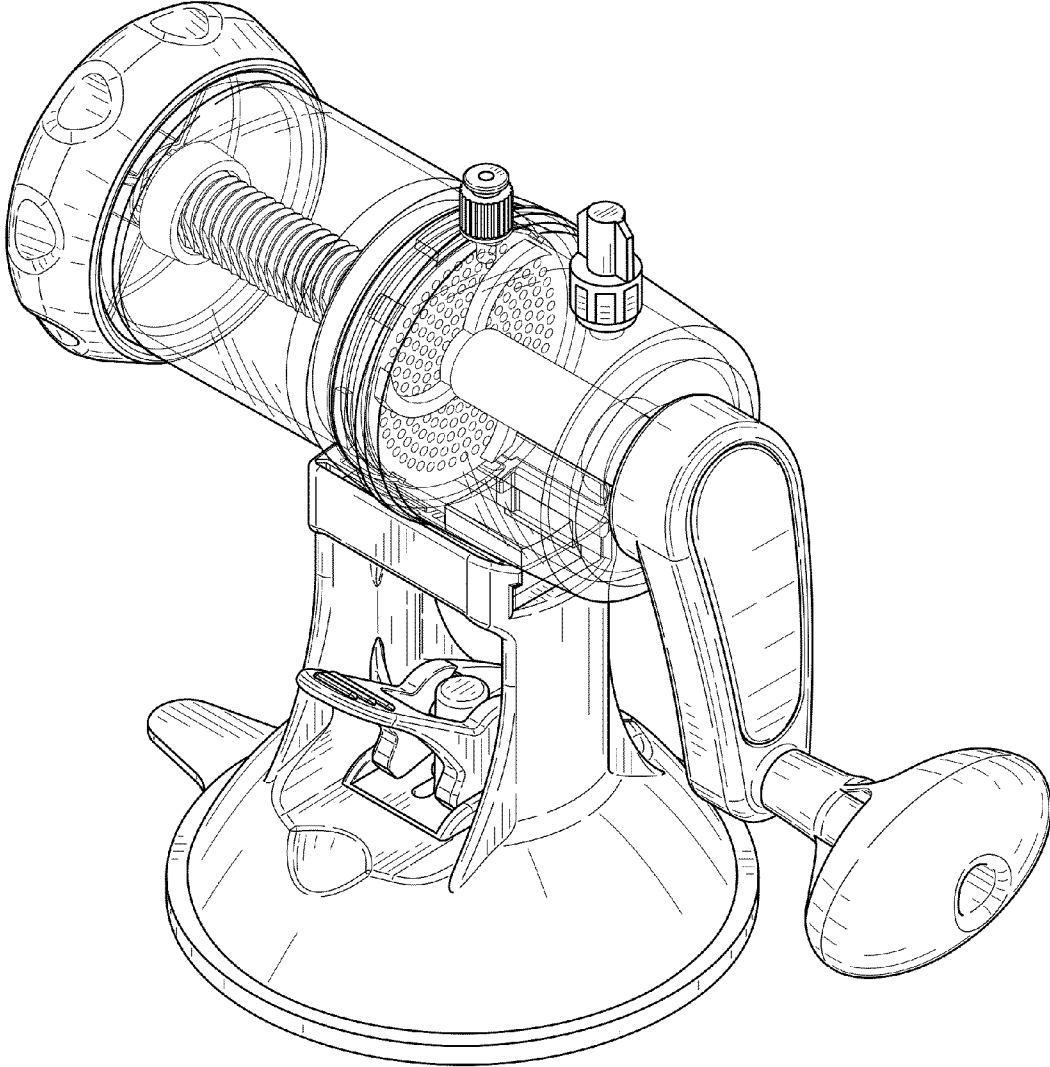

FIG. 1

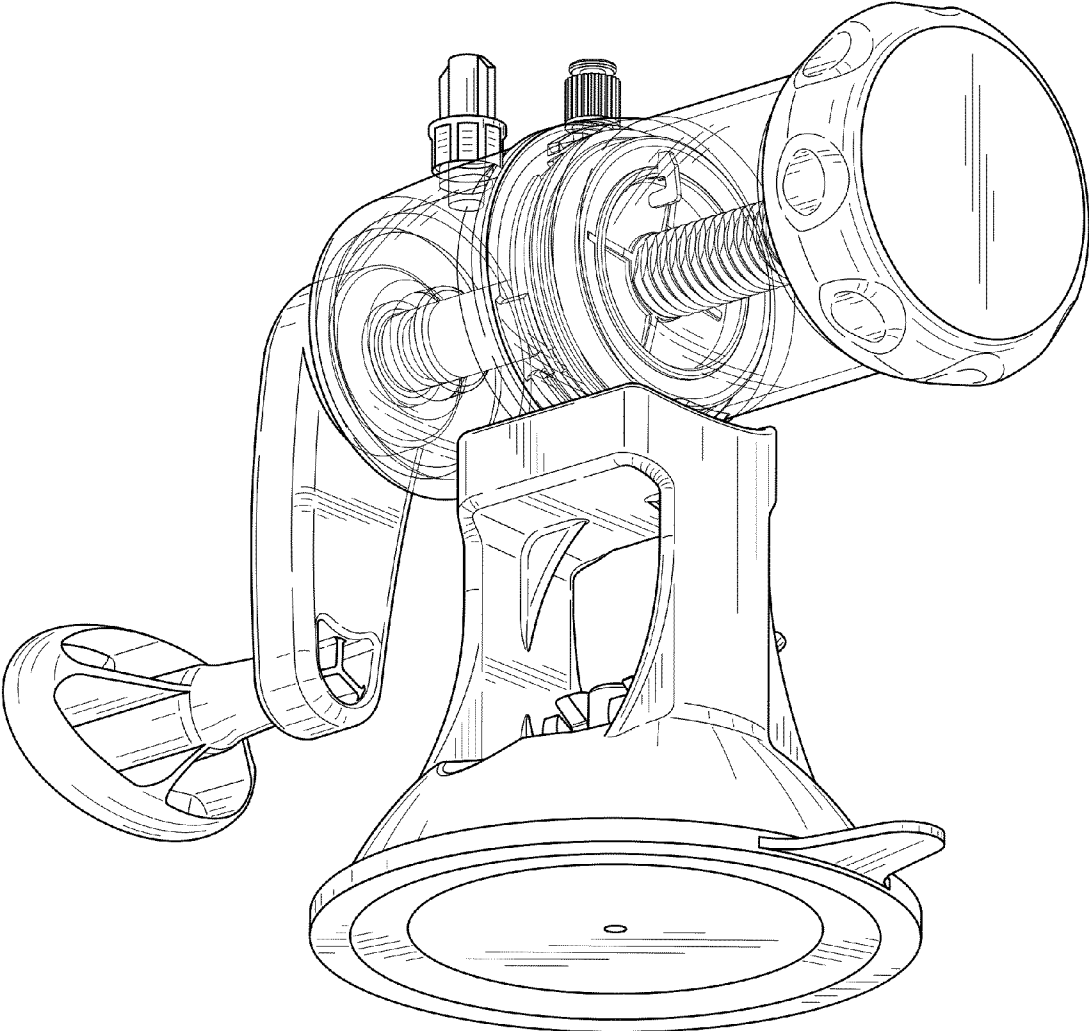

FIG. 2

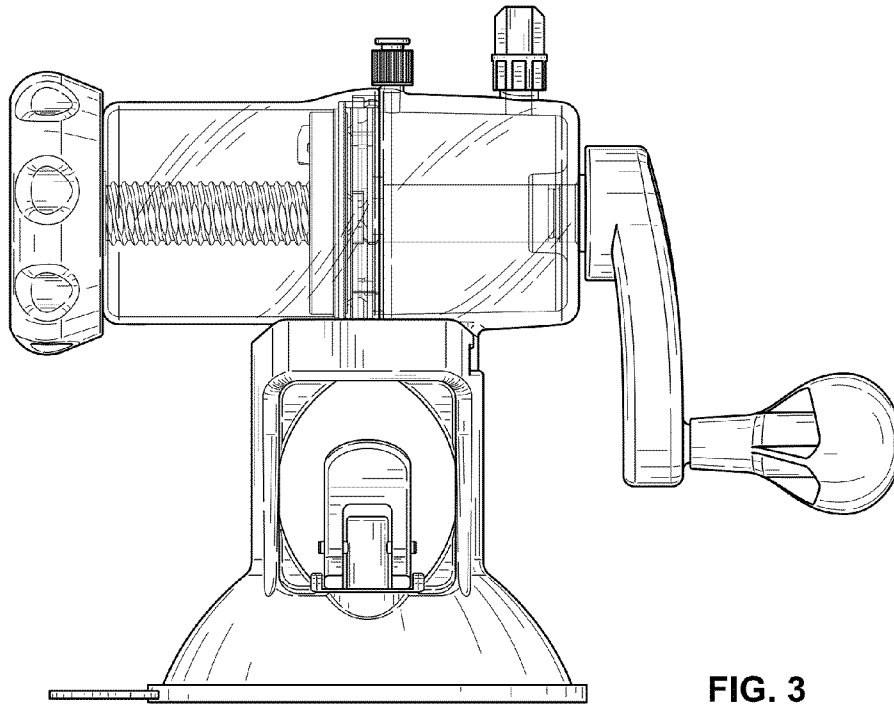

FIG. 3

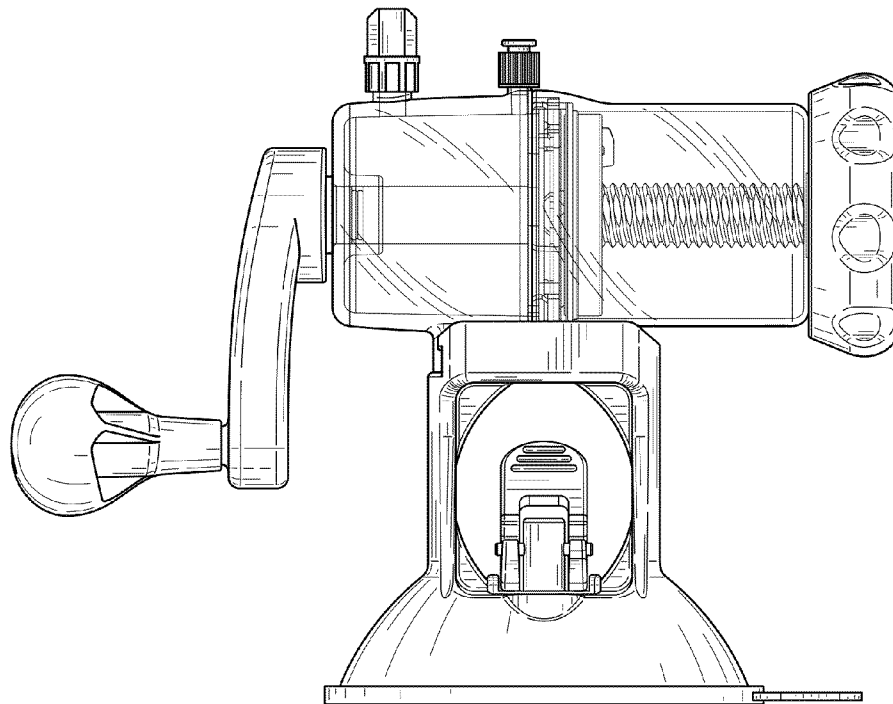

FIG. 4

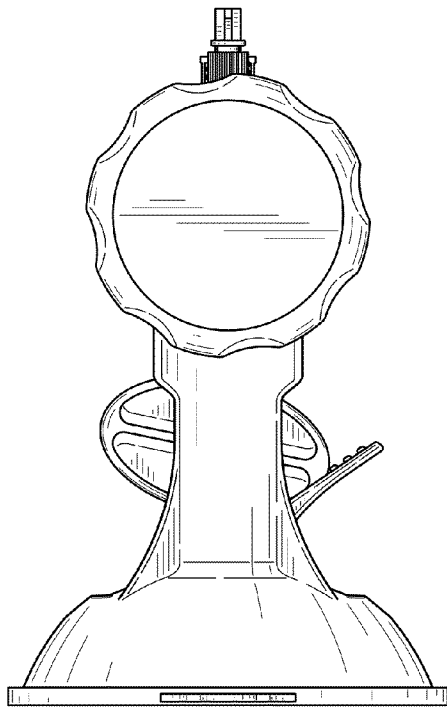

FIG. 5

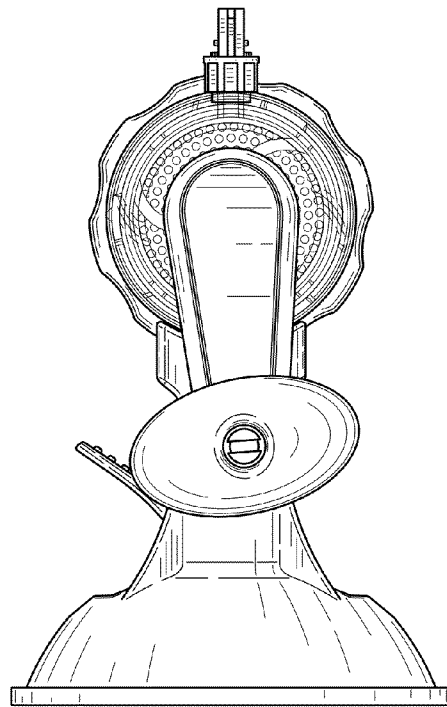

FIG. 6

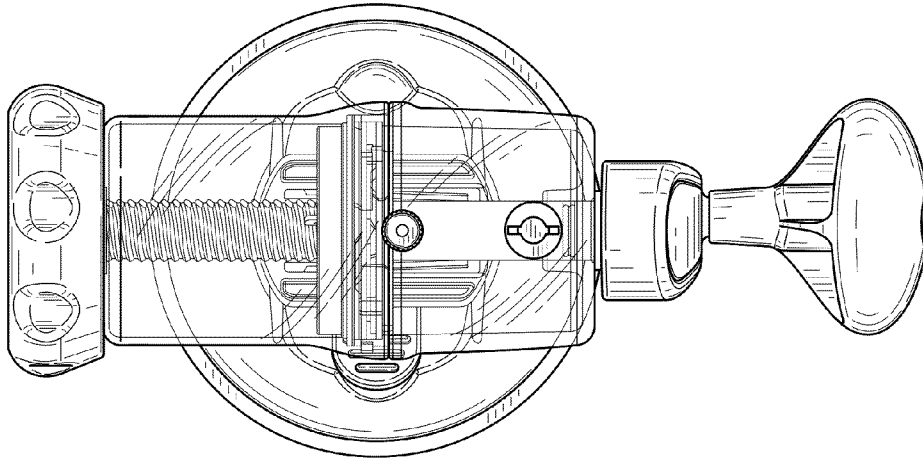

FIG. 7

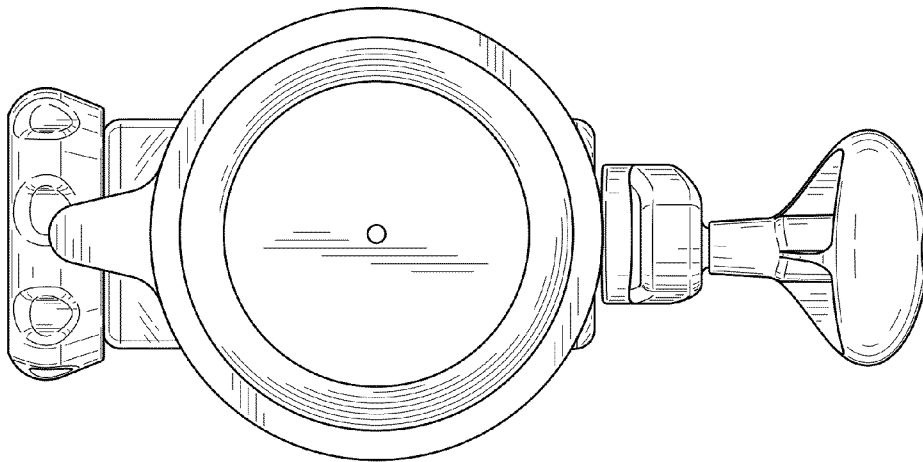

FIG. 8

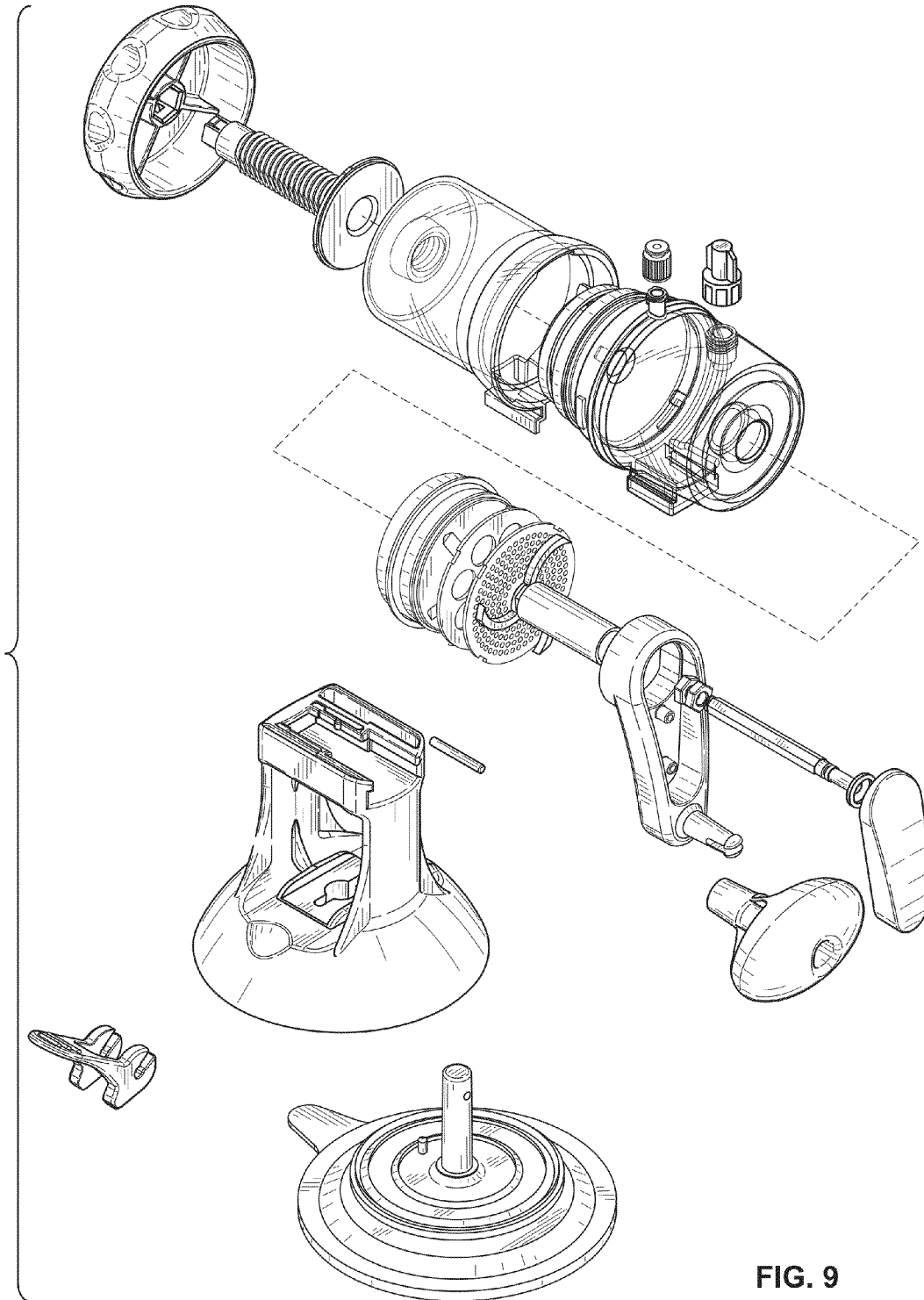

FIG. 9

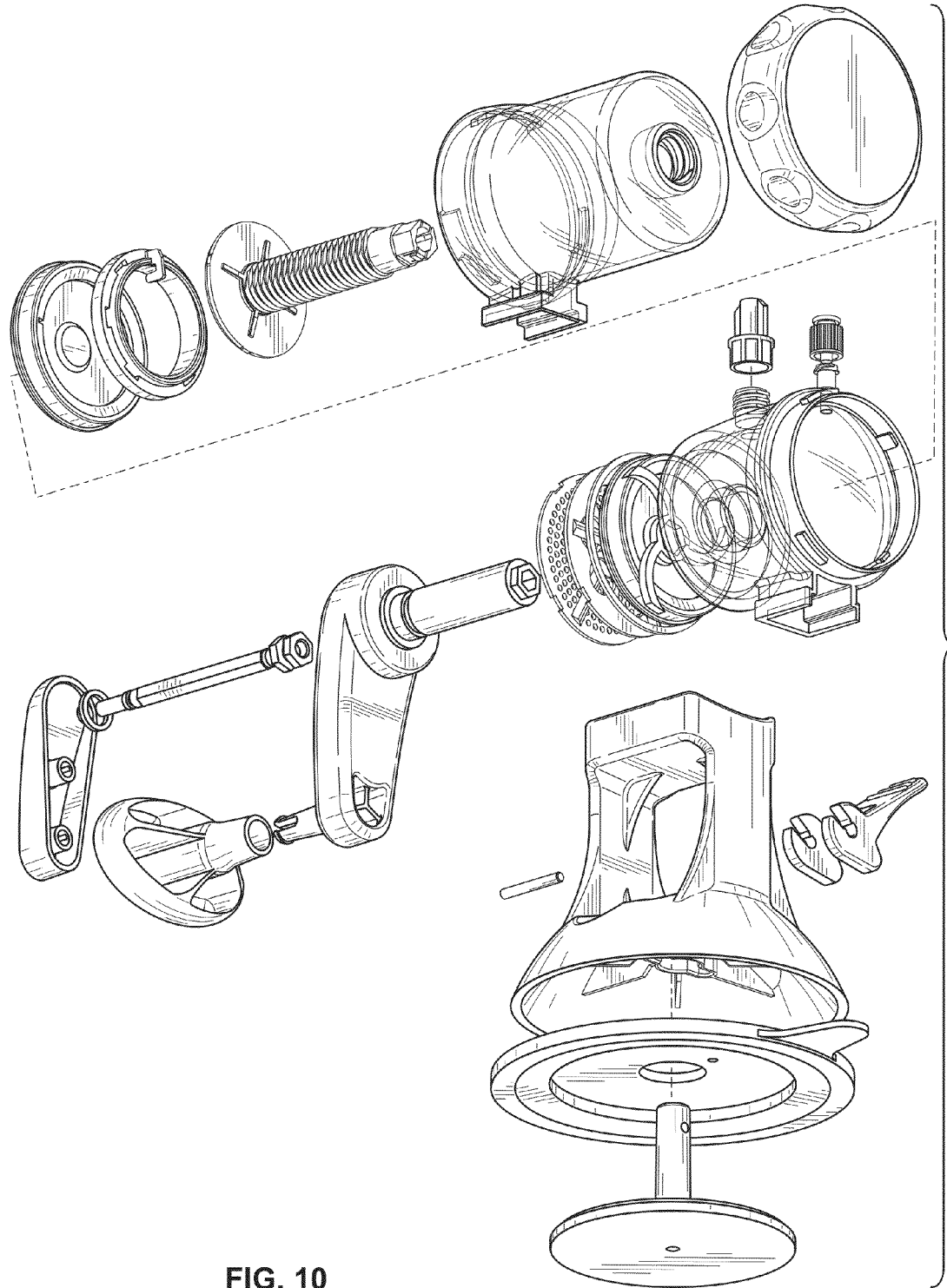

FIG. 10