

(12) PATENT
(19) AUSTRALIAN PATENT OFFICE

(11) Application No. AU 199922941 B2
(10) Patent No. 756448

(54) Title
Coordinated multi-axis hinge and closure using the same

(51)⁷ International Patent Classification(s)
B65D 047/08 E05D 001/02

(21) Application No: **199922941**

(22) Application Date: **1999.01.27**

(87) WIPO No: **WO99/57029**

(30) Priority Data

(31) Number	(32) Date	(33) Country
981/98	1998.04.30	CH

(43) Publication Date : **1999.11.23**

(43) Publication Journal Date : **2000.02.03**

(44) Accepted Journal Date : **2003.01.16**

(71) Applicant(s)
Creanova AG

(72) Inventor(s)
Louis Lagler; Rudolf Rentsch

(74) Agent/Attorney
DAVIES COLLISON CAVE, 1 Little Collins Street, MELBOURNE VIC 3000

(56) Related Art
US 4403712
EP 0778218
DE 4335107

2294/99



PCT

WORLD INTELLECTUAL PROPERTY ORGANIZATION
International Bureau

INTERNATIONAL APPLICATION PUBLISHED UNDER THE PATENT COOPERATION TREATY (PCT)

<p>(51) International Patent Classification⁶ : B65D 47/08, E05D 1/02</p>	<p>A1</p>	<p>(11) International Publication Number: WO 99/57029 (43) International Publication Date: 11 November 1999 (11.11.99)</p>
<p>(21) International Application Number: PCT/IB99/00277 (22) International Filing Date: 27 January 1999 (27.01.99) (30) Priority Data: 981/98 30 April 1998 (30.04.98) CH (71) Applicant (for all designated States except US): CREANOVA AG [CH/CH]; Mühlegasse 12a, CH-6340 Baar (CH). (72) Inventors; and (75) Inventors/Applicants (for US only): LAGLER, Louis [CH/CH]; Nurenbergstrasse 25, CH-8037 Zürich (CH). RENTSCH, Rudolf [CH/CH]; Pfannenstielstrasse 11, CH-8706 Meilen (CH). (74) Agent: RENTSCH, Rudolf, A.; Brem & Borer, Tödistrasse 52, Postfach 1071, CH-8039 Zürich (CH).</p>		<p>(81) Designated States: AL, AM, AT, AU, AZ, BA, BB, BG, BR, BY, CA, CH, CN, CU, CZ, DE, DK, EE, ES, FI, GB, GD, GE, GH, GM, HR, HU, ID, IL, IN, IS, JP, KE, KG, KP, KR, KZ, LC, LK, LR, LS, LT, LU, LV, MD, MG, MK, MN, MW, MX, NO, NZ, PL, PT, RO, RU, SD, SE, SG, SI, SK, SL, TJ, TM, TR, TT, UA, UG, US, UZ, VN, YU, ZW, ARIPO patent (GH, GM, KE, LS, MW, SD, SZ, UG, ZW), Eurasian patent (AM, AZ, BY, KG, KZ, MD, RU, TJ, TM), European patent (AT, BE, CH, CY, DE, DK, ES, FI, FR, GB, GR, IE, IT, LU, MC, NL, PT, SE), OAPI patent (BF, BJ, CF, CG, CI, CM, GA, GN, GW, ML, MR, NE, SN, TD, TG).</p> <p>Published With international search report.</p>

(54) Title: COORDINATED MULTI-AXIS HINGE AND CLOSURE USING THE SAME

(57) Abstract

A coordinated multi axis hinge arrangement provides a snap action between stable open and closed states. When the hinges operate between the stable open and closed states across a dead center position, resilient forces imparted by torsionally rigid connecting elements (33.1, 33.2) of the hinge to adjacent hinge parts such as body and lid elements are transferred by coupling or transmitting areas (45.1, 45.2) adjacent the bending regions (34.1 - 34.4) or film hinges to remote resilient deformation energy storage areas (40.1 - 40.3). As the inge passes a dead center position, this energy is in turn supplied and returned to the rigid connecting elements to impart snap action to the closure. The closure may be cast as a single piece of plastic material and may be cast in the open position.

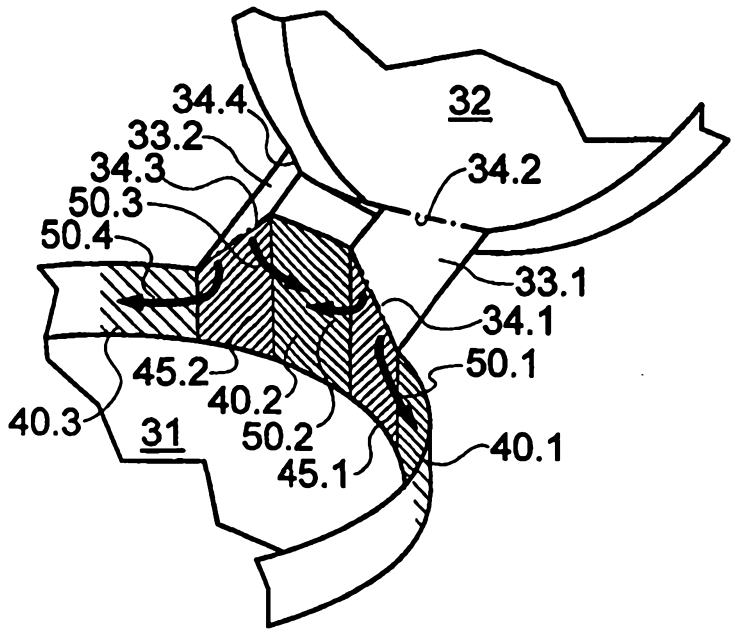

Coordinated Multi-Axis Hinge and Closure Using the Same

Filed of the Invention

The present application is generally directed to a snap hinge, particularly a hinge usable in injection molded one-piece plastic closures.

5 Background of the Invention

The dispensing of consumable materials such as cosmetics and food stuffs create a demand for dispensing closures which can be manufactured economically and which fully seal the container when in the closed position. Because such closures are often utilized in
10 disposable containers for consumer goods, the cost of such closures is of substantial concern, as is the desire for closures which have excellent consumer convenience and a good tactile feel.

In the past, many closures a first class of closures employing a single main hinge connection or a plurality of main hinges aligned
15 along a single axis was often used. Some of these hinges employ an intermediate element such as a spring element or taut band in order to produce a dead center position where tension within the closure will prevent the closure from stably resting in its position, driving the closure either more fully open, or more fully closed. Such an unstable
20 equilibrium position is generally thought desirable in closures of this type as it provides the consumer with a closure with a generally good tactile feel. However, such single main hinge type closures, even provided with such an intermediate element, require significant offset of the main hinge from the closure contour due to the simple
25 movement of the cap as illustrated in Figure 3 of the present application. These hinges are also difficult to mold due to asymmetrical flow paths during molding. This therefore places the hinge well outside the closure body, considered undesirable in such

closures. Such single main hinge type closures are also often difficult to mold. An example of such devices employing a single main hinge include those disclosed by U.S. Patent No. 4,403,712 to Weisinger and U.S. Patent No. 4,638,916 to Beck et al.

5 A second class of hinges employs a multiple joint axis hinge arrangement. However, the opening and closing of the multiple joints is uncoordinated in this class of hinges. An example of such an uncoordinated hinge is U.S. Patent No. 5,148,912 to Nozawa where two hinge parts are connected to each other via two resilient belts which
10 are flexible or elastic over their entire length. In such a closure, the resilient belt plates connecting the hinged lid to the body bend or flex over their entire length in order to produce a force driving the hinge into a single stable position, the hinge otherwise being continually stressed. A lack of coordination between the multiple axis of the hinge
15 allows the lid to move in multiple paths with respect to the closure, there being no coordination between the closure parts.

A third class of hinges are coordinated multi-axis hinge arrangements which generally pivot about two hinge axes and are designed with two, typically tensionless, stable positions, a dead center
20 or unstable equilibrium position being provided therebetween. In such a hinge, an over centering force tends to drive the hinge to one of two stable positions from the dead center position. Such hinges are believed to be the invention of an inventor of the present application and are best described in U.S. Patent No. 5,794,308 entitled "Hinge".
25 Although at the time the '308 invention was invented, the model of Figure 1 of the present application was not known, the invention of the '308 patent can generally be described with reference to this model. Such hinges employ a pair of hinge elements including a flexurally rigid intermediate hinge part 4 coupled to the first and second hinge
30 parts, typically the body and lid of a closure via coupling elements 6, 7

which provide elastic relieving movement in the region of a dead centre position.

In other words, in the '308 patent, coupling elements which are connected directly to the substantially flexurally rigid intermediate hinge part, absorb elastic deformation to produce the snap action forces in the region of the dead centre position. While the teachings of the '308 patent provide an excellent closure, since the time of the invention of this patent, the inventors of the present application have discovered various ways to vary and enhance the performance of hinges of the type discussed in the '308 patent.

Summary of the Invention

10 It is accordingly an object of the present invention to improve upon the design of the aforementioned hinges by, at least in part, transferring the forces of deformation created by the flexurally or torsionally rigid intermediate parts or connecting arms to one or more resilient areas facilitating storage of this energy remotely from the coupling elements or areas to which the flexurally rigid connecting arms are connected.

15 It is a further object of the present application to increase the capacity of a closure to absorb resilient energy from torsionally stiff connecting arms, by transferring some or all of that energy to areas not directly adjacent from the bending areas to which the connecting arms are connected, thereby improving the resilient snap-action force obtained from a particular closure geometry, particularly in closures of relatively small size.

20 According to the present invention there is provided (a) multi-axis hinge arrangement with at least two stable positions, comprising

- (b) a first hinge part;
- (c) a second hinge part;
- (d) at least two connecting arms spaced a distance apart;
- 25 (e) at least four bending regions connecting each of said connecting arms directly to the first hinge part and second hinge part;
- (f) each connecting arm having at least four sides while two non-adjointing sides of each connecting arm are formed by one of the bending regions;
- (g) said connecting arms having a cross-section which is substantially
- 30 torsionally stiff, characterised in that
- (h) at least two transmitting areas are arranged adjoining to said bending regions; and
- (i) resilient areas of the hinge parts, elastically deformable upon opening or

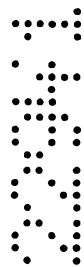

closing of the multi-axis hinge arrangement, are connected to the transmitting areas; whereby

(j) in the closed position the bending regions of the first connecting arm define a first plane and the bending regions of the second connecting arm define a second plane
5 intersecting said first plane at an angle;

(k) the bending regions of the first connecting arm and the bending regions of the second connecting arm are arranged in an angle to each other in order to allow at least two relative positions of the hinge parts where the connecting arms and/or the hinge parts are substantially without structural deformation.

10 The invention also provides a mold suitable for a hinge arrangement as defined above characterised in that at least one dimension of the mold for corresponding geometry in a first position of the hinge arrangement is bigger in a first direction compared to a second direction for the same corresponding geometry in a second position of the hinge arrangement.

15 Although these coupling or transmitting areas may be themselves resilient and store energy as contemplated by the '308 patent, the inventive embodiments of the present application transfer some or all of this energy to resilient areas remote from the bending areas.

20 According to further teachings of the present application, the offset of the hinge from the parting line between the body and lid of the closure may be varied in order to accomplish desired effects such as, in one embodiment, providing a latching mechanism, and in another embodiment, avoiding interference between the lid and body during closure, even in the presence of protrusions from the closure body or unusual shapes designed into the closure lid.

25 According to further teachings of the present application, the molds used to produce such a coordinated multi-axis hinge arrangement may be designed to compensate for mold shrinkage in the body, lid and connecting arms and still produce desired geometry's. Optimal thin film hinges operate as efficient bending areas for the hinge.

30 The accomplishment of the objectives of the present application will become more fully apparent from the detailed description given hereafter from which the spirit and scope of the invention will become apparent to those skilled in the art. It should be understood, however, that the specific examples and description presented herein below are merely exemplary of the present invention which is described solely by the appended claims.



Brief Description of the Drawings

The present invention will be more fully understood from the detailed description given herein below and the accompanying drawings which should not be considered limiting to the invention described in the appended claims.

Fig. 1 illustrates a mechanical model of a coordinated multi-axis hinge arrangement that is of the class employed in the embodiments of the present application;

Fig. 2 illustrates specific coordinated movement of the multi-axis hinge arrangement of Figure 1;

Fig. 3 is a family of cinematic curves showing typical paths of a plurality of points in space rotating around a main hinge connection of the type well known in the prior art;

Figs. 4a) to 4c) each show a family of cinematic curves of various coordinated multi-axis hinge arrangements of the type illustrated in Figures 1 and 2;

Fig. 5 schematically illustrates an embodiment of a multi-axis hinge arrangement in a closure according to one embodiment of the present application;

Fig. 6 is a close up view of a portion of the schematic embodiment of Fig. 5;

Fig. 7 is an illustration of the embodiment of Figs. 5 and 6 of the present application showing in greater detail an arrangement of energy accumulating buffers as used in accordance with the teachings of the present application;

Fig. 8 illustrates an embodiment of the present application employing an alternative arrangement of energy accumulating buffers in accordance with the teachings of the present application;

Fig. 9 illustrates an embodiment of the present application having curved bending areas;

Fig. 10a), 10b) shows paths of specific points in space of a hinge which constrains the first and second hinge parts into paths which interfere (Fig. 10a) and which avoids interference (Fig. 10b);

5 Fig. 11 and Fig. 12 are perspective views illustrating additional embodiments of the hinge of the present application employing the principals explained with reference to Figs. 10a), 10b);

Figure 13 is a side view of still another embodiment of a hinge produced in accordance with the teachings of the present application;

10 Fig. 14 is a side view of another embodiment of a multi-axis hinge arrangement of the present application illustrating manufacturing shrinkage compensation principals; and

Figs. (15a) and (15b) show a cross section through an improved film hinge produced in accordance with one aspect of the present application in the open (Fig. 15a) and closed (Fig. 15b) states.

15

Detailed Description of the Preferred Embodiments

A better understanding of the present invention may be had through an examination of the present detailed description which, when examined in connection with the accompanying drawings sets forth preferred embodiments of the inventions described herein. It should be understood that like elements in the various figures are generally identified with like reference numbers.

20 During the course of development of various coordinated multi-access hinge arrangements, the inventors have discovered that such a hinge may be described with reference to the mechanical model 1 of the coordinated multi-axis hinge arrangement is illustrated in Figure 1 of the present application. The mechanical model 1 of the multi-axis hinge arrangement has been discovered by the inventors as a way to describe the operation of the coordinated multi-axis hinge arrangement

25

30 in its most general or basic form. The mechanical model 1 of a

coordinated multi-axis hinge arrangement includes a lower or first hinge part 2, an upper or second hinge part 3, and at least one connecting arm 4 connecting the lower or first hinge part 2 and upper or second hinge part 3 via first and second rotational axes 5, 6. Note that while in the embodiment of Figure 1, these axes are illustrated as parallel, it is possible to skew these axes with respect to each other in either of two dimensions.

A coordinating device 7 provides the coordination for the multi-axis hinge arrangement. In the mechanical model of Figure 1, the coordinating device 7 is represented by two pairs of mating bevel wheels 8, 9 and a transmission or gearbox 10 which may have any suitable coupling ratio, allowing the rate of pivot of the hinge about the first and second rotational axes 5 and 6, to differ in accordance with the transmission ratio selected for the gear box 10. Alternatively, as may be desired to achieve special effects, the transmission ration of the gearbox 10 may be made non-linear. However, it is within the contemplation of the present invention that some defined coordination exists between the pivoting of the lower and upper hinge parts 2, 3, to the connecting arm 4.

Figure 2 illustrates how movement between the lower hinge part 2, connecting arm 4, and upper hinge part 3 is coordinated according to a coordinated multi-axis hinge arrangement of the type disclosed in the present application. In the example of Figure 2, the gearbox 10 of the coordinating device 7 exhibits a 1 to 1 ratio. Figure 2a) shows the multi-axis hinge arrangement 1 in a closed position. Figure 2d) shows the multi-axis hinge arrangement fully open with the upper and lower hinge parts 180° with respect to each other. Figures 2b) and 2c) show the multi-axis hinge arrangement 1 in intermediate positions. These figures collectively illustrate how the coordinating device 7 ensures that the relative movement between the lower hinge part 2 and the

connecting arm 4, on the one hand, and the upper hinge part 3 and connecting arm 4, on the other hand, are always coordinated relative to each other.

5 While the gearbox 10 is illustrated with a transmission ratio of 1 to 1 in this illustration, resulting in symmetrical rotation of the upper hinge part 3 about the rotation axis 6 as compared to the lower hinge part 2 about the rotation axis 5, a different transmission ratio may be selected for the gear box to vary the rate of angular change provided at pivots 5, 6.

10 In contrast with the coordinated movement of a coordinated multi-axis hinge arrangement as illustrated in Figures 1 and 2, uncoordinated multi-axis hinge arrangements are unstable because at least one degree of freedom remains undefined. If the coordination device 7 is removed from a multi-axis hinge, relative movement of the
15 two hinge parts 2, 3 with respect to the connecting arm 4 cannot be determined. The upper hinge part 3 may completely open with respect to the connecting arm 4 before the lower hinge part 2 begins to open with respect to the connecting part 4. Thus, a particular position in space may be reached by multiple movement paths in such an
20 uncoordinated device.

Figure 3 illustrates the path of a rectangle traveling through space under constraint of a single hinge connection 21. This so-called cinematic representation illustrates the movement of various points of the rectangle 20 as it rotates through space about the main hinge
25 connection 21 along path P1. This is representative of a first class of hinges where a single hinge pivot is utilized. The main hinge connection 21 is, in the Figure 3 example, perpendicular to the plane of the figure. Thus, the rectangle 20 moves from a first position 20.1 to a second position 20.2. The paths P1 of all points of the rectangle 20

are circular in this example where the two rectangles 20.1 and 20.2 are connected directly by the main hinge connection 21.

In the case of closures, if it is desirable to remove a lid as represented by the rectangle 20 to an open position well away from the closure body. In such a single hinge arrangement, the main hinge connection 21 must be spaced away well from the container to accomplish this objective. This produces a substantial protrusion from the closure body, an aspect of such single hinge closures considered undesirable.

A completely different concept of the coordinated multi-axis hinge arrangement is apparent from an examination of figures 4a) to 4c). A review of cinematic representations of these figures, as compared to the cinematic representation of a single hinge as illustrated in Figure 3, clearly illustrates the functional advantages of a coordinated multi-axis hinge.

Figure 4a) shows a first typical path pattern P2 of points within the rectangle 22 as it pivots 180° around a coordinated multi-axis hinge arrangement 1 as illustrated in Figure 1, for example. It is apparent that, because there is no main hinge, the rectangle 22 in the closed position 22.1 is displaced a significant distance by the coordinated multi-axis hinge arrangement 1 into the open position 22.2. The path pattern P2 is clearly not circular. Thus, it is apparent from this example that a coordinated multi-axis hinge arrangement may be designed to prevent one element from interfering with specific other elements.

By modifying the distance of the rotation axes 5, 6 in space and the transmission ratio of the coordinating device 7, substantial effect can be had on the path pattern and nearly any desired path can be realized. Examples of two further possible path patterns are illustrated in the cinematic diagrams of Figures 4b) and 4c). It is very important

WO 99/57029

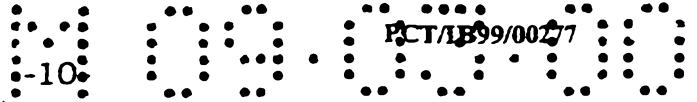

to understand that substantial contact between the upper and lower hinge parts or, in a practical example, a closure which employs a hinge such as illustrated in Figure 1, must generally be avoided to achieve the desired motion. (Compare, however Figure 10a and 11 which make use of intentional interference to produce a latching action.) It is apparent from Figures 4b and 4c that, as compared to a single main hinge connection as illustrated by the cinematic of Figure 3, many different requirements may be fulfilled by adjusting the parameters of a coordinated multi-axis hinge arrangement as taught herein.

Figure 5 shows schematically an embodiment of a coordinated multi-axis hinge arrangement 1 in a closure 30. As with other embodiments described in the present application, the movement and coordination of the multi-axis hinge arrangement is similar to that described above in the mechanical model of Figure 1.

The closure 30 is drawn in a half open position and is useful in defining a number of the terms utilized in the present application. The closure comprises a body 31, which corresponds to the lower hinge part 2 of Figure 1, a lid 32, which corresponds to the upper hinge part 3 of Figure 1, and two connecting arms 33.1, 33.2 ~~which~~ ^{spaced a distance apart and separated by a gap. The connecting arms 33.1, 33.2 do} correspond to the substantially flexurally rigid intermediate parts 4 of the embodiments of the aforementioned U.S. Patent No. 5,794,308 and the connecting elements 5 of our copending International Application No. PCT/EP96/02780.

Each connecting arm 33.1, 33.2 of Figure 5 is connected to a coupling portion of the body 31 and the lid 32 of the closure 30 by bending regions 34.1-34.4 which may be, in a preferred embodiment, film hinges. The bending regions 34.1-34.4 are arranged in this embodiment such that each connecting arm 33.1, 33.2 is trapezoidally shaped. Although the bending regions are shown symmetrically in Figure 5, an asymmetric arrangement of the bending regions 34.1-34.4



is also possible within the contemplation of the present invention, and would result in the same effect as changing the transmission ratio of the coordinating device 7 of the mechanical model of Figure 1. The coordination between the hinge parts 2, 3 is achieved by the physical arrangement of the bending regions 34.1-34.4 in space and the design of the connecting elements 33.1, 33.2. In this style of hinge, two types of coordination are obtained. The first type of coordination is the coordination between the multiple hinge axes such as already described. A second type of "coordination" is the lateral and torsional stability of the hinge which increases as the hinge travels over its intended path from open to closed. This is particularly important since this second form of stability allows mechanized closing of the closure. Absent this lateral and torsional stability, the hinge would not self center on the closed position and the closure could not be used in automated filing and packaging machinery. Further details of this relationship will be explained hereinafter.

The arrangement illustrated in Figure 5 requires a predetermined amount of flexure or resiliency of one or more of the components of the closure 30 of Figure 5. Such resiliency can be accomplished in accordance with the teachings of U.S. Patent No. 5,794,308 as will be described further hereinafter, may be accomplished according to the teachings of our pending application PCT/EP96/02780, or may be accomplished according to further teachings set forth in the present application. To make use of such resiliency, and accomplish energy storage through this structural deformation, the bending regions 34.1-34.4 are arranged in space in a desired fashion. As such design aspects are described in further detail in the aforementioned prior patent and pending application, which are incorporated herein by reference, further explanation of these aspects of the invention are not presented here.

When the closure 30 is opened or closed, the geometry of the connecting elements 33.1, 33.2 causes specific deformation of the structure of the hinge area. The degree and extent of deformation of various aspects of the closure geometry is dependent on the angles ω and ϕ , and of an opening angle α of the closure. In one preferred embodiment of the present application, the structural deformation is designed to be zero at times when the closure 30 is in a stable position, in the exemplary embodiment, the fully opened and fully closed position, with α being zero in the fully closed position and the designed maximum in the fully opened position. However, structural deformation and its corresponding accumulation of force can be designed into a closure in any position, for example the fully closed position.

If the closure is designed so that a opening force is residually maintained when the closure is in the fully closed position, a greater snap action effect upon opening may be desirably obtained. Alternatively, a residual closing force may be desirable when the closure is in the fully closed position so as to better maintain the closed state.

Figure 6 is a partial close-up view of the embodiment of Figure 5. In addition to the detail of Figure 5, as explained further in the above-mentioned PCT/EP96/02780 application, Figure 6 better illustrates the forces which, upon actuation of the closure of Figure 6, produce structural deformation in some portion of the closure.

The connecting elements 33.1, 33.2 are desirably trapezoidally shaped as a truncated base of a triangle. The shorter edges of 36.1, 36.2 which serves to truncate the triangles, producing the trapezoidal connecting elements 33.1, 33.2, are subject to compression forces, resisting these compression forces to produce deformation forces for application to another portion of the closure structure as illustrated in

35.3, 35.4, 35.5, and 35.8. Similarly, the longer edges 37.1, 37.2 of each connecting element are subjected to tension during the hinge closure process and produce deformation forces 35.1, 35.2, 35.6, and 35.7. Thus, each of the connecting arms 33.1, 33.2 supplies a force to
5 the remainder of the closure structure which must be absorbed, in some fashion, by resilient deformation. The importance of this resilient deformation and the resiliency of the body 31 and lid 32 of the closure will be described in greater detail with reference to Figures 7 and 8.

Desirably according to the teachings of this aspect of the present
10 application, the connecting elements 33.1, 33.2 should be relatively stiff, and must be sufficiently stiff such that the compression forces along the shorter edges 36.1, 36.2 do not buckle the shorter or compression edges 36.1, 36.2 due to the deformation forces 35.3, 35.4, 35.5, and 35.6. Additionally, it is highly desirable that the connecting
15 elements 33.1, 33.2 be relatively torsionally stiff. Preferably, the cross-section of each of the connecting elements 33.1., 33.2 along arrow cc of this figure be sufficiently torsionally stiff.

The torsional stiffness of the overall closure 30 can be modified by increasing the distance B between apexes to increase the overall
20 torsional stiffness of the closure 30. Increasing the torsional stiffness of the overall closure is accomplished as the dimension B between apexes defined by the bending regions 34.1, 34.2, 34.3, and 34.4 increases. Desirably, in order to produce an acceptable level of torsional stiffness of the overall container 30, apexes 38.1, 38.2 should
25 be spaced apart from each other by distance B selected to preferably at least half the distance of the length of each shorter edge 36.1, 36.2. By increasing B, a stable and self-centering construction of the hinge arrangement may be obtained. However, B cannot increase without limit as this increases the distance between the apexes and must
30 necessarily increase the angle ω and/or the angle ϕ . In contrast,

5 constructions with a small distance B or where the apexes 38.1, 38.2 of the triangles defined by the bending regions 34.1, 34.2, 34.3, and 34.4, when coincident, produce a hinge construction which is torsionally unstable and flimsy with unsatisfying and insufficient coordination between hinge parts, especially in the fully opened position.

Figure 7 is a further explanation of the embodiment of Figure 6 and shows significant inventive features of the present application. The importance of these features may be best understood after an
10 understanding of the operation of the '308 patent already discussed above. In the '308 patent, as illustrated, for example, in Figure 6 thereof, a substantially flexurally rigid intermediate part 4.1, 4.2 of each hinge element is connected to the body and lid with upper and lower coupling elements 6.1, 6.2, 7.1, and 7.2 which correspond
15 generally to coupling or transmitting areas 45.1, 45.2 of the body 31 of the closure 30 as illustrated in Figure 7. Of course, equivalent coupling elements to the body coupling elements 45.1, 45.2 are also provided on the cap 32 of the closure 30 in accordance with the teachings of the present application.

20 As explained in the '308 patent, the coupling elements are elongation relieving elements of a resilient nature. While the equivalent portions of the present application, the coupling or transmitting areas 45.1, 45.2 may be resilient, the present application transmits some or all of this force to adjacent resilient areas including resilient area 40.2
25 provided between the coupling or transmitting areas 45.1, 45.2, and the resilient areas 40.1, 40.3, provided on opposed sides of the coupling or transmitting areas 45.1, 45.2.

Thus, according to the teachings of the present application as illustrated in Figure 7, at least some induced structural deformation is
30 supplied from the coupling or transmitting areas 45.1, 45.2 in the

embodiment of the present invention to at least one resilient area 40.1-40.3. This has a secondary benefit. In the '308 patent, the coupling elements 6, 7 had to be made resilient to absorb these deformation forces. In contrast, in the present application, these coupling or transmitting areas 45.1, 45.2 need not be made resilient, although they may be so made. Instead, according to the teachings of the present application, the coupling or transmitting areas 45.1, 45.2 transmit some or all of the deformation forces to adjacent resilient areas 40.1-40.3. This allows increased flexibility in hinge design and gives the hinge designer the choice of where deformation energy is absorbed for retransmission to produce the desired snap action driving the hinge to one of its stable states.

Figure 7 illustrates this transfer of deformation forces into one of the resilient areas 40.1-40.3. Referring once again to Figure 6, the structural deformation forces are illustrated by arrows 35.1-35.8. These forces are transmitted from the coupling or transmitting areas 45.1, 45.2 as illustrated in Figure 7 by arrows 50.1-50.4. In accordance with the teachings of the present application, these resilient areas 40.1-40.3, alone, or in conjunction with the coupling or transmitting areas 45.1, 45.2 function as energy accumulating buffers to temporarily store the structural deformation energy which may be later returned to the hinge to provide snap action closure or opening to one of the hinges stable states. When energy is released from the resilient areas 40.1-40.3, it is transmitted back to the hinge via the same paths indicated by arrows 50.1-50.4, but of course in the opposite way to that delivered.

According to the teachings of the present application, the energy supplied to the hinge to drive it from one stable to another is absorbed by induced structural deformation. Whereas in the '308 patent, the energy was absorbed entirely within the coupling or transmitting areas

45.1, 45.2, in accordance with the teachings of Figure 7, some or all of this energy is transmitted to the adjoining resilient areas 40.1-40.3. Thus, if the designer designs the coupling or transmitting areas 45.1, 45.2 to be substantially rigid, substantially all deformation energy is transmitted to the adjacent resilient areas 40.1-40.3. Alternatively, within the contemplation of the present application, the designer may design the closure so that some energy is buffered in the coupling or transmitting areas 45.1, 45.2 while some area is transferred to the adjacent resilient areas.

This solution accomplishes the beneficial result of transmitting the accumulated energy over a greater area, allowing sufficient snap action force even in situations where the coupling or transmitting areas 45.1, 45.2 are relatively small. Thus, the techniques of the present application allow the inventive techniques of the applicants such as that disclosed by the prior '308 patent, to be more flexibly implemented and implemented to smaller closures.

Although the coupling and transmitting areas 45.1, 45.2 and resilient areas 40.1-40.3 may be visibly identifiable in the finished closure, this need not be the case. For design reasons, it may be desirable to completely integrate these closure parts. Particularly, in situations where deformation energy is intended to be transmitted between the coupling or transmitting areas 45.1, 45.2 to the resilient areas 40.1-40.3, all areas may have the same wall thickness.

The deformation energy stored in the energy accumulating buffers including the resilient areas 40.1-40.3 are desirably supplied with a "flat" force-deformation characteristic. This is best accomplished by relatively long spring elements, as compared to the degree of deformation imparted. Such a flat characteristic is best obtained through the energy storage accomplished through a deformation by bending. Thus, the resilient areas 40.1-40.3 are

preferably built as resilient elements intended to deform by bending. It is important to understand that the required bending would not be achievable with hinge arrangements having a main hinge rotation axis, since that would cause a complex stress characteristic typically causing the problems described above.

It is apparent from the foregoing that the resilient areas 40.1-40.3 can substantially increase the amount of spring energy absorbed from the connecting arms 33.1, 33.2, as passed through the coupling or transmitting areas 45.1, 45.2. Thus, a substantially improved result is achieved by the use of such areas.

Figure 8 shows a schematic alternative embodiment of the invention. Figure 8 principally differs from Figure 7 in that the outer, longer edges 51.1, 51.2 of the connecting elements 33.1, 33.2 are spatially curved. This may be primarily for the purpose of improving the design integration in a specific closure design such as illustrated in Figure 13. However, in this example, the curved areas along the outer edges 51.1, 51.2 of the connecting elements 33.1, 33.2 can be used as energy accumulating buffers providing additional bending deformation. In this circumstance, areas along the inner edges 52.1, 52.2 must nevertheless be built with sufficient stiffness to prevent buckling or bending as previously discussed, thereby providing the required torsional stiffness to cause each entire connecting elements 33.1, 33.2 to be torsionally stiff.

In this embodiment, some deformation force is also transmitted to the coupling or transmitting elements 45.1, 45.2 and further to the resilient areas 40.1-40.3. In this embodiment, the coupling or transmitting elements and resilient areas are less clearly defined, with respect to each other, the entire localized area of the body 31 functioning as an energy accumulating buffer. Similarly, it should be understood that all of the description of transmission of forces, with

respect to Figure 7 and 8, although described specifically with respect to the body 31 of the closure 30, equally apply to the lid 32 of the closure 30. It should be understood that in accordance with the principals of the present application, it is not necessary to accumulate
5 energy in both the body and lid. However, at least one resilient area must be provided in the body, lid, or connecting arm in accordance with the teachings of the present application.

The identification of resilient areas and coupling or transmitting areas is not easily ascertainable when an individual closure is viewed
10 without technical aid. However, the identification of these areas may be done by any known technique. Perhaps the easiest way to identify such areas is through the use of Finite Element (FE) Analysis techniques available through a number of commercially available computer aided design and analysis programs.

Figure 9 illustrates an alternative embodiment of the closure of
15 the present invention where the bending regions 34.1, 34.2 are curved or arcuate. Again, the connecting elements, in this case 33.1, connect the closure body 31 from the closure lid 32, which elements intersect along a parting plane 60 which in this embodiment is somewhat
20 stepped. Otherwise, the embodiment of Figure 9 is generally similar to the other embodiments of the present application.

Figure 10a shows the paths 56.1, 56.2 of two points P' and P'' located at the back of a lid 32 of a closure 30 according to the
25 embodiment of Figure 11. In Figure 11, a rectangle 54 is shown schematically on the body 31 of the closure 30. (see Figure 11). This rectangle is also schematically illustrated in Fig. 10a. The direction of viewing is indicated by an arrow A of Figure 11. The location of a parting plane of the closure 30 is illustrated as line 60 in Figure 10a which is illustrated as the median parting plane line 60.1 in Figure 11.

The rectangle 55 shows schematically the back portion 55 of the lid 32 (which extends downwardly from the lid 32 in the closed position) in the area of the points P' and P'' in a closed position (55.1) and in open position (55.2). The two dotted curves 56.1 and 56.2 show the movement of the two points P' and P'' in space as the closure is moved between the open and closed positions. It is obvious that the two points P' and P'' of rectangle 55 collide with the rectangle 54. This means that the lid 32 of closure 30 would, in this case, collide with the body 31. This collision can be avoided in accordance with the teachings of the present application. This can be done, by moving the points P' and P'' on specific, suitable pattern paths as shown in the cinematic curves of figures 4a) to 4c).

Figure 10b) shows a preferred example of a solution to the problem explained above with respect to Figure 10a), which prevents a collision between the body 31 and the lid 32, is shown in Figure 10b). By moving the points P' and P'' vertically by a distance E above the parting plane 60 and inclining them by an angle δ (see also figure 14), the two points P' and P'' move on completely different paths 57.1, 57.2 and do not collide with the lower rectangle 54 which represents the lower body 31 of the closure 30. The points P' and P'' are here positioned in a way, that they move immediately out and away from the contour of the rectangle 54 representing the lower body 31. A preferred embodiment of such a solution is shown in figure 12.

Figure 11 shows a preferred embodiment of a closure 30 with a coordinated multi-axis hinge arrangement 1. The closure 30 comprises a body 31, a lid 32 and two connecting arms 33.1 and 33.2 which are connected to the body 31 and the lid 32 over bending areas 34.1 to 34.4. A parting plane 60 of the closure 30 is indicated by the numbers 60.1, 60.2 and 60.3. Points P' and P'' are located in this embodiment on the parting plane 60.

The connecting arms 33.1,33.2 are here built with a thick compression area and a thin tension area. The thick compression area is sufficiently thick to avoid not buckling or bending under pressure load. This areas have, in this embodiment, no functional significance for the snap effect of the closure 30. The cross section of the connecting elements is built torsionally stiff in accordance with the teachings of the present application.

Coupling or transmitting elements 45.1, 45.2 in this environment may, depending upon the application desired, accumulate a portion of the deformation energy. The coupling or transmitting elements 45.1, 45.2 further transmit some or all of the structural deformation energy produced by the multi-axis hinge arrangement 1 to adjoining resilient areas 40, which work alone or in conjunction with other elements as the energy accumulating buffer. Thus the resilient areas may optionally operate in conjunction with the coupling or transmitting elements 45.1, 45.2. Here the energy is temporarily stored, preferably by bending deformation. Arrows 50.1-50.5 illustrate this energy transmission process.

The closure of Figure 11 is built with a locking mechanism. The points P' and P'' collide in a desirable and controlled manner with the body 31 such that the coordinated multi-axis hinge arrangement is locked or latched. The hinge can be pressed on the back of the body 51 near point P'1 to release the latch. The latching mechanism is described in detail in Swiss Patent Application No. 0981/98 filed April 30, 1998, which is hereby incorporated by reference into the present application.

Figure 12 shows another preferred embodiment of the closure 30 with a coordinated multi-axis hinge arrangement. As with other embodiments described above, the closure comprises a body 31, a lid 32, and two connecting arms 33.1, 33.2 connected to the body 31 and

lid 32 by bending areas 34.1-34.4. At this point, it should be mentioned that the bending areas 34.1-34.4 may be desirably constructed in any of the embodiments of the present application as thin film hinges casting the entirety of the closure including body and lid as a single monolithic plastic construction. Thus, it is apparent that a closure according to the teachings of the present application may be efficiently constructed.

The parting plane 60 of the closure 30 is indicated by numbers 60.1, 60.2, and 60.3 of Figure 12. Points P' and P'' are arranged in this embodiment on a surface 61, thus shown in Figure 14, which is located a vertical distance E, as best shown in Figures 10b) and 14 from the parting plane 60. The distance E is chosen so that no collision between the lid 32 and body 31 occurs at any time. The plane 61 is desirably inclined with respect to the parting plane 60 by the angle δ as illustrated in Figures 10 and 14. Plane 61 corresponds, in a closed position of the closure 30, with a surface 62 of the body 30 such that no gap exists and optimal design is achieved.

In this embodiment, the coupling or transmitting areas 45.1-45.6 transmit structural deformation and its attendant energy storage produced by the multi-axis hinge arrangement 1 to adjoining resilient areas 40.1-40.3. Of course, the transmitting areas 40.1-40.6 may also be resiliently deformable in order to also store energy. The resilient areas 40.1-40.3 with any resilient coupling or transmitting areas 45.1-45.6 work as energy accumulating buffers where the deformation energy is temporarily stored, preferably by bending deformation. This energy is then returned to the hinges to provide snap-action closure.

The dark arrows 50 of Figure 12 illustrate this transmission process as described above with respect to Figure 11. Figure 12 differs somewhat from the other figures in that Figure 12 illustrates that the resilient area 40.3 need not be located immediately beside the multi-

axis hinge arrangement 1, but can be located anywhere on the closure parts so long as transmission of structural deformation and its attendant energy storage is guaranteed. In accordance with the teachings of the present application, through the use of known modeling techniques, the size of the resilient areas, amount of energy stored therein, the amount or force transferred from the hinges, the location of the stable positions and virtually any other aspect of the hinges performance may be controlled.

The connecting elements 33.1, 33.2 in the embodiment of Figure 2 are relatively thick planar plates which are torsionally stiff. The connecting elements 33.1, 33.2 are relatively flat on both surfaces thereof and the outer shape thereof is shaped conformally to the exterior of the closure so that the connecting elements 33.1, 33.2 may be optimally integrated to the outer shape of the closure. Of course, the design of the cross-section of the connecting elements must consider the requirements of torsional stiffness, the tension and compression forces, and the shrinking behavior of the selected geometry. However, the principles described herein can be followed to achieve a hinge design having the desired performance characteristics.

Figure 13 shows another preferred embodiment of the closure 30 employing the coordinated multi-axis hinge arrangement 1 of the present invention. The closure 30 in the Figure 13 embodiment is distinguished from the other closures in several significant respects. Firstly, the parting plane 60 of the closure 30 is stepped as indicated by the closure lines 60.1, 60.2. Although this prevents the closure lid from retracting away from the closure body to the same degree as the other embodiments, this may be necessary in order to accomplish specific design configurations such as the complex shape of Figure 13.

The multi-axis hinge arrangement 1 is arranged in this embodiment at an angle τ which serves to raise the lid parting plane

60.1 with respect to the body parting plane 60.2, when the closure is in the open position. The purpose of this angle is self-evident, in order to allow the closure lid to clear the protruding and very high spout 65 of the closure body 31.

5 In this embodiment, points P' and P'' are arranged in a surface 61 which is located a vertical distance E from the parting plane 60 as illustrated in Figures 10b) and 14. This distance E is chosen in this embodiment so that no collision occurs between the lid and the body. The plane 61 is inclined with respect to the parting plane 60 by an
10 angle δ as has already been discussed with reference to Figures 10b) and 14. The plane 61 corresponds, in the closed position of the closure 30, with surface 62 of the body 31, such that no gap exists and an optimal design is achieved in this embodiment.

 The resilient areas 40.1-40.3 in this embodiment work as energy
15 accumulating buffers in the manner already discussed with the other embodiments. Note that in this embodiment, however, the deformation energy may be transmitted to a portion of the cap considerably distant from the hinge area, which transmission is within the contemplation of the embodiments of the present application.

20 The embodiment of Figure 13 further differs from the other embodiments in that the connecting elements 33.1, 33.2 are provided with a spatially curved "knee" shape such that their outer shape is conformally configured with the exterior design of the body 31 and its lid 32. An area along the longer knee shaped connecting element free
25 edge 37, by virtue of the bend or knee in the connecting element 31.1 or 31.2 can function, in part, as an accumulating buffer, illustrated as the resilient area 40.3. Thus, in this embodiment which employs a knee in the hinge connecting element, a portion of the energy for the snap effect may be stored by bending deformation within the hinge,
30 itself.

Of course, the shorter connecting element free edge 36 in this embodiment must be built so that it does not buckle or deform under the compression pressure it is subjected to. Further, in order to provide a good snap action hinge, the connecting elements 33.1 and 33.2 must be built with sufficient torsional stiffness.

Figure 14 is a partial side view of the closure in the direction of arrow A in Figure 11. Figure 14, in addition to illustrating the lid 32 in the open position, further includes a partial sectional view of the lid in the closed position, illustrated as 32.2. Points P' and P'' are here arranged in a surface 61 located at a vertical distance E (as explained with reference to Figures 10b) and 14) from the parting plane 60. Once again, the distance E is chosen to avoid any collision between the lid 32 and body 31. Also, once again, the plane 61 is inclined with respect to the parting plane 60 by the angle δ achieving optimal design in the manner already discussed.

Figure 14 exhibits, however, another advantageous attribute. It is particularly difficult to build a precise snap-hinge, primarily due to the many geometrical restrictions of the construction and the problem of material shrinkage. The coordinated multi-axis hinge arrangement of the present application provides a technique for compensation of shrinkage and other problems due to geometry. With respect to an x-y coordinate system as illustrated in the figure, material shrinkage in the mold is normally bigger in the direction of y as compared to x, as explained with reference to the directional arrows of Figure 14. By casting the closure in the open state and by compensating for shrinkage by adjusting the links of the hinges, shrinkage may be properly compensated for. This can be accomplished by adjusting the dimensions K1 and K2 in Figure 14.

Figure 15 illustrates a preferred design, in cross-section, of the film hinge 70 employed as the bending areas 34.1-34.4 in one

preferred embodiment of the present application. Figure 15a) illustrates the film hinge 70 when the closure is in an open position, while Figure 15b) illustrates the hinge when in a closed position. Adjoining the film hinge 70 is a connecting element 33 and a body 31 or lid 32. As is apparent from the embodiments discussed early in this application, the body 31, lid 32, and connecting elements 33 are often curved in order to accomplish desired design characteristics. The film hinge 70 should be designed with this consideration in mind. The film hinge should be designed for precise fitment into available space and should be designed by parts of a mold which may be easily separated when the mold is open. Therefore, it is important that the design of the film hinge be insensitive to geometric imperfections.

The film hinge illustrated in Figures 15a), 15b) includes an inner part defined by two planes 72, 73 which are inclined by an angle χ with respect to vertical to obtain the best flow patterns of material and for optimized load transmission. The angle χ should be in a range such that the thinnest possible thickness 74 of the film hinge 70 is still clearly defined.

The planes 72, 73 are connected by a cylindrically shaped surface 78 which defines the inner edge of the film hinge 70. The outside of the film hinge is formed by a plane 75 which runs from a first outer surface 76 which, in this example, is curved to a second outer surface which is also curved. Note that the first outer surface 76 is the outer surface of the connecting element 33 while the second outer surface 77 is the outer surface of the body 31 or lid 32. As can be seen from Figure 15a), the width of the plane 75 approaches zero at the relative center of the film hinge 70 due to the arcuate curvature of the surfaces 76, 77. However, this plane has a significant width at the edge of the film hinge 70, also due to this curvature. Of course, all of the film hinges should be polished or very smooth.

Figure 15b) illustrates a further advantage of this film hinge. In the closed position, the plane 72 is generally aligned with the plane 73, and aids in the positioning of the connecting element 33. Further, this function is to generally strengthen the film hinge when in the closed position. This is especially useful in the area of the short or inside free edge of the connecting element 33. This is indicated by arrow 79. Of course, additional elements on the body 31 and lid 32 of the closure 30 may be used to aid in positioning the connecting element 33. This is indicated, for example, by arrows 80. As is further self-evident, the surfaces 72, 73 need not be planar and other shaped surfaces may be utilized although such surfaces should be preferably conformal in the closed position.

A further advantage of the film hinge 70 of Figure 15 is that the film hinge can also work as an energy accumulating buffer by an appropriate design. For example, the alternative embodiment of Figure 9 accumulates energy in the hinge through the curvature of the hinge. Of course, other non-linear hinge designs can accomplish the same purpose.

From the above-described embodiments of the present invention, it is apparent that the present invention may be modified as would occur to one of ordinary skill in the art without departing from the scope of the present invention and should be defined solely by the appended claims. Changes and modifications of this system contemplated by the present preferred embodiments will be apparent to one of ordinary skill in the art. Thus, it is apparent that the invention may be varied in many ways without departing from its spirit and scope, and all such modifications would be obvious to one of ordinary skill in the art. Accordingly, the proper scope of the present invention should be defined solely by the appended claims.

The reference to any prior art in this specification is not, and should not be taken as, an acknowledgment or any form of suggestion that that prior art forms part of the common general knowledge in Australia.

Throughout this specification and the claims which follow, unless the context
5 requires otherwise, the word "comprise", and variations such as "comprises" and
"comprising", will be understood to imply the inclusion of a stated integer or step or group
of integers or steps but not the exclusion of any other integer or step or group of integers or
steps.

10

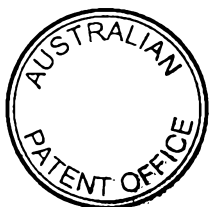
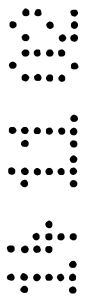
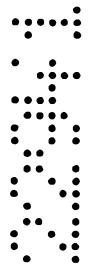

THE CLAIMS DEFINING THE INVENTION ARE AS FOLLOWS:

1. (a) Multi-axis hinge arrangement with at least two stable positions, comprising
(b) a first hinge part;
5 (c) a second hinge part;
(d) at least two connecting arms spaced a distance apart;
(e) at least four bending regions connecting each of said connecting arms directly to the first hinge part and second hinge part;

(f) each connecting arm having at least four sides while two non-adjointing
10 sides of each connecting arm are formed by one of the bending regions;

(g) said connecting arms having a cross-section which is substantially torsionally stiff, characterised in that

(h) at least two transmitting areas are arranged adjoining to said bending regions; and

15 (i) resilient areas of the hinge parts, elastically deformable upon opening or closing of the multi-axis hinge arrangement, are connected to the transmitting areas; whereby

(j) in the closed position the bending regions of the first connecting arm define a first plane and the bending regions of the second connecting arm define a second plane
20 intersecting said first plane at an angle;

(k) the bending regions of the first connecting arm and the bending regions of the second connecting arm are arranged in an angle to each other in order to allow at least two relative positions of the hinge parts where the connecting arms and/or the hinge parts are substantially without structural deformation.

25

2. Hinge arrangement according to claim 1, wherein at least one of the connecting arms and/or the hinge parts is stress free in at least one of the stable positions of the hinge arrangement.

30

3. Hinge arrangement according to claim 1 or 2, wherein said resilient area stores energy through resilient deformation upon opening or closing of the multi-axis hinge arrangement and that said stored energy provides a snap action forcing the hinge

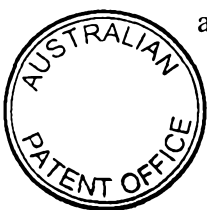

arrangement to return in one of the stable positions.

4. Hinge arrangement according to any one of the previous claims, wherein apexes defined by the bending regions are spaced apart by a distance being at least substantially
5 half the length of a shorter edge of a connecting arm.

5. Hinge arrangement according to any one of the previous claims, wherein at least one of the edges of said connecting arms is stiff and does not buckle under compression forces.

10

6. Hinge arrangement according to any one of the previous claims, characterised in that at least one of the connecting arms has a resilient area which is elastically deformable upon opening or closing of the multi-axis hinge arrangement.

15

7. Hinge arrangement according to any one of the previous claims, characterised in that the connecting arms are at least partially spatially curved.

20

8. Hinge arrangement according to any one of the previous claims, characterised in that the bending regions are elastically deformable and thereby are suitable to store energy upon opening or closing of the multi-axis hinge arrangement and that said stored energy supports a snap action forcing the hinge arrangement to return in one of the stable positions.

25

9. Hinge arrangement according to any one of the previous claims, characterised in that the bending regions are arranged symmetrical or asymmetrical with respect to the hinge parts.

10. Hinge arrangement according to any one of the previous claims, characterised in that said first hinge part is a body and the second hinge part is a lid of a closure.

30



11. Hinge arrangement according to claim 10, characterised in that said resilient area is arranged in the area of a free edge of the body.

12. Hinge arrangement according to claim 10 or 11, characterised in that said resilient
5 area is arranged in the area of a free edge of the lid.

13. Hinge arrangement according to any one of claims 10, 11 or 12, characterised in that said resilient area is arranged between two transmitting areas.

10 14. Hinge arrangement according to any one of claims 10 to 13, characterised in that the connecting arms are in the closed position of the closure integrated in the outer contour of the closure, such that no part is protruding substantially over the surrounding area.

15 15. Hinge arrangement according to any one of claims 10 to 14, characterised in that the hinge arrangement is arranged at an angle τ with respect to a parting plane.

16. Hinge arrangement according to any one of claims 10 to 15, characterised in that the connecting arms have at least partially a substantially constant thickness.

20 17. Hinge arrangement according to any one of claims 10 to 16, characterised in that the connecting arms at their shorter free edge have a greater thickness compared to their thickness at their longer free edge.

25 18. Hinge arrangement according to any one of claims 10 to 17, characterised in that a least one surface of the lid is arranged out of a parting plane and cooperates with a corresponding surface of the body such that no gap occurs in the closed position of the closure.

30 19. Hinge arrangement according to any one of claims 10 to 18, characterised in that the bending regions are embodied as film hinges.



20. Hinge arrangement according to claim 19, characterised in that the film hinges having a cross-section that is delimited by a circular curve on one side and a straight line or a circular curve on the opposite side.

5 21. Hinge arrangement according to claim 19 or 20, characterised in that a plane is arranged at an angle χ with respect to a parting plane at the inner side of the film hinge to engage with a corresponding plane of the connecting element in the closed position of the closure to position the connecting element.

10 22. Hinge arrangement according to any one of claims 10 to 21, characterised in that at least one bending area is curved.

15 23. Hinge arrangement according to any one of claims 10 to 22, characterised in that one of the stable positions of the hinge arrangement is outside the design range, past the closed position of the closure such that the hinge arrangement is being biased with a closing force.

20 24. The hinge arrangement according to any one of claims 10 to 23, characterised in that one of the stable positions of the hinge arrangement is outside the design range, before the closed position of the closure such that the hinge arrangement is biased with an opening force.

25 25. Hinge arrangement according to any one of the previous claims, characterised in that the transmitting areas are integrated within the hinge parts.

26. Hinge arrangement according to any one of the previous claims, characterised in that at least the transmitting areas arranged at one hinge part are substantially stiff.

30 27. Mold suitable for a hinge arrangement according to any one of claims 1 to 25, characterised in that at least one dimension of the mold for corresponding geometry in a first position of the hinge arrangement is bigger in a first direction compared to a second



direction for the same corresponding geometry in a second position of the hinge arrangement.

28. A multi-axis hinge arrangement substantially as hereinbefore described with
5 reference to the accompanying drawings.

29. A mold suitable for a hinge arrangement substantially as hereinbefore described
with reference to the accompanying drawings.

10

15

DATED this 12th day of November, 2002

CREANOVA AG

20 By its Patent Attorneys

DAVIES COLLISON CAVE



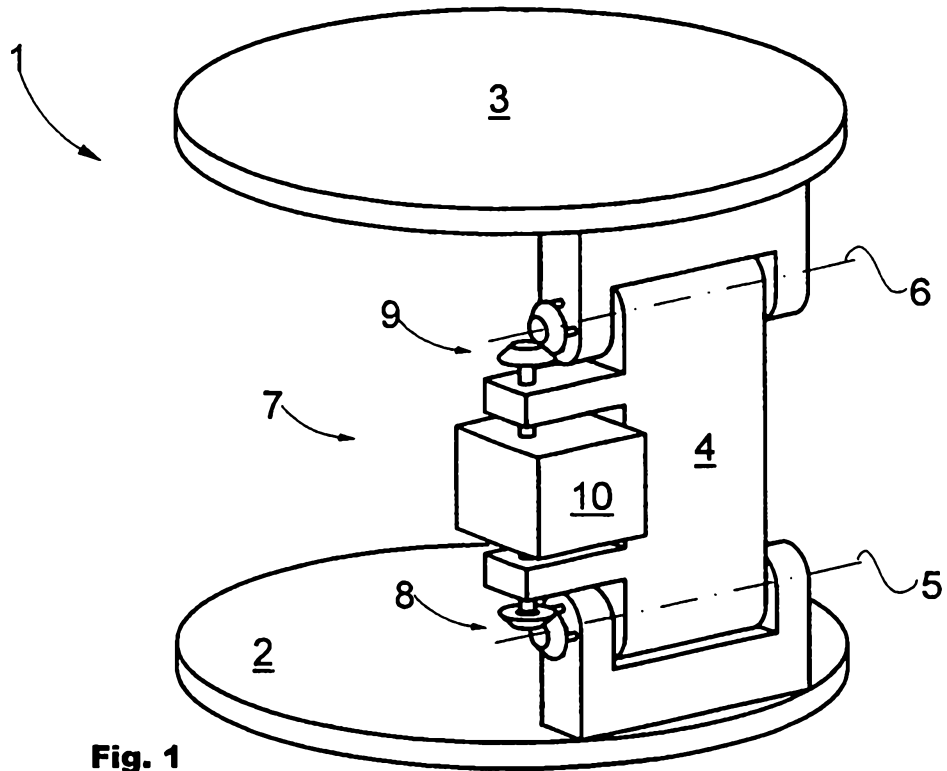

Fig. 1

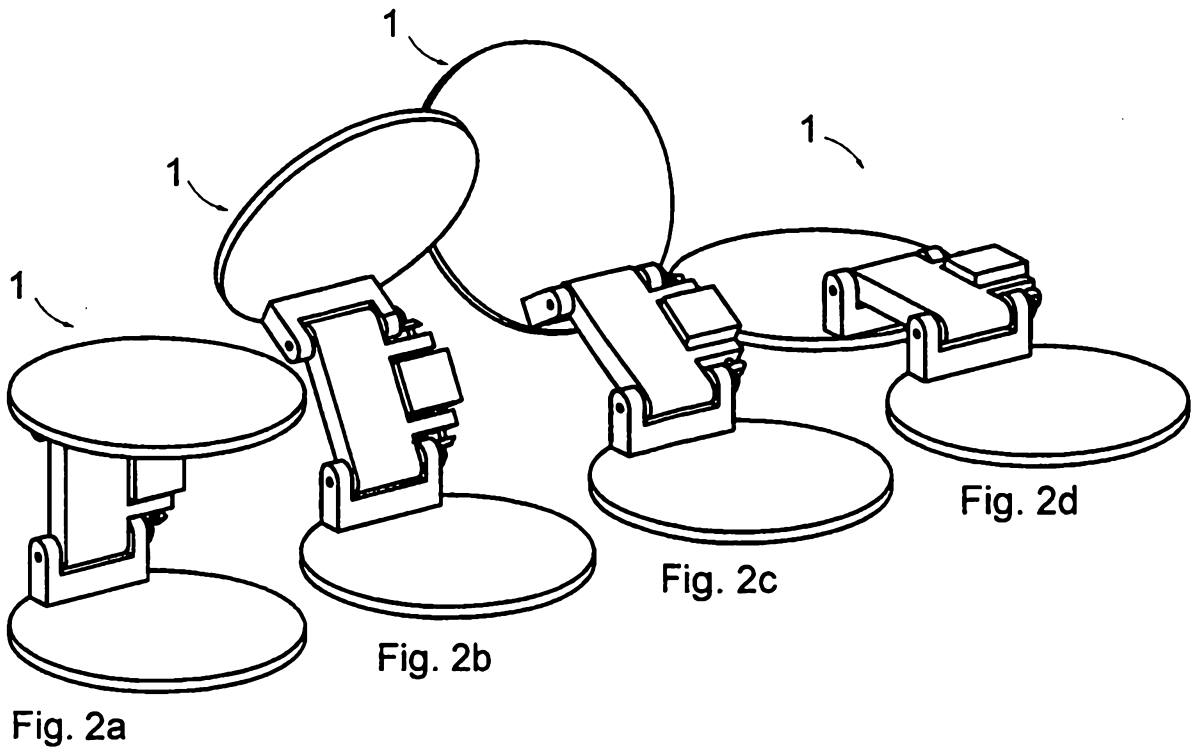

Fig. 2a

Fig. 2b

Fig. 2c

Fig. 2d

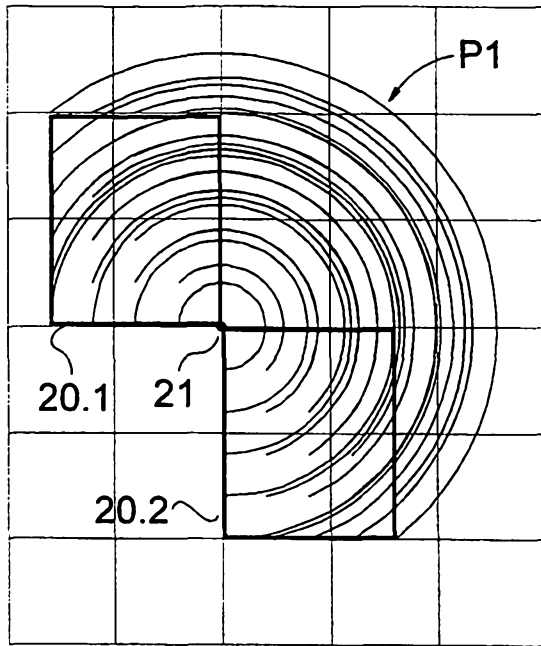

Fig. 3

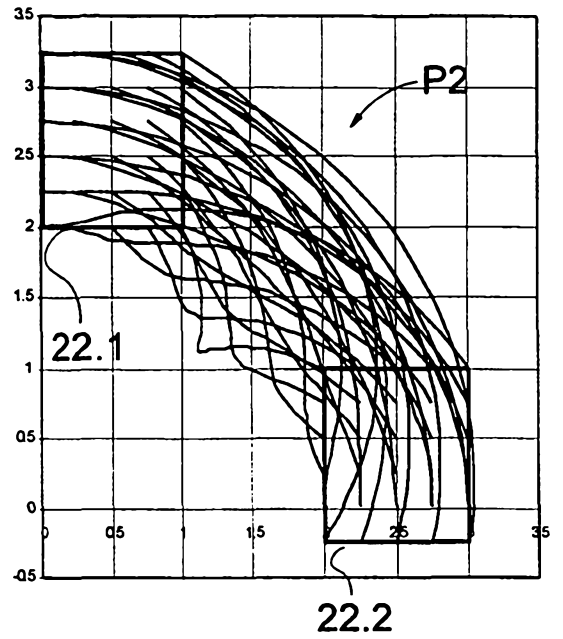

Fig. 4a

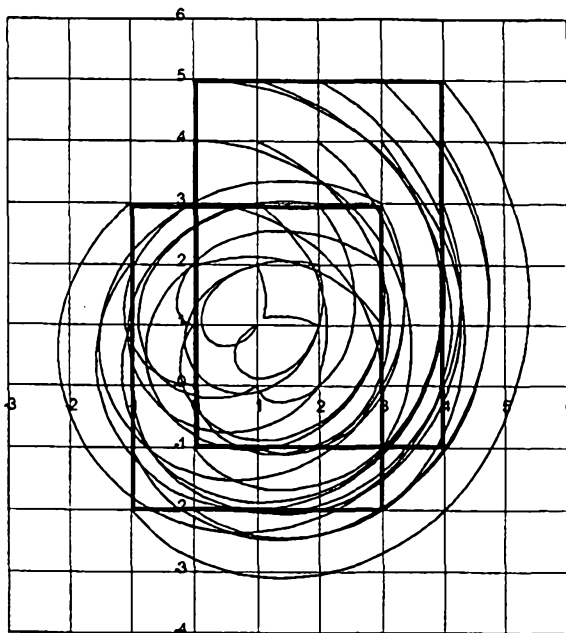

Fig. 4b

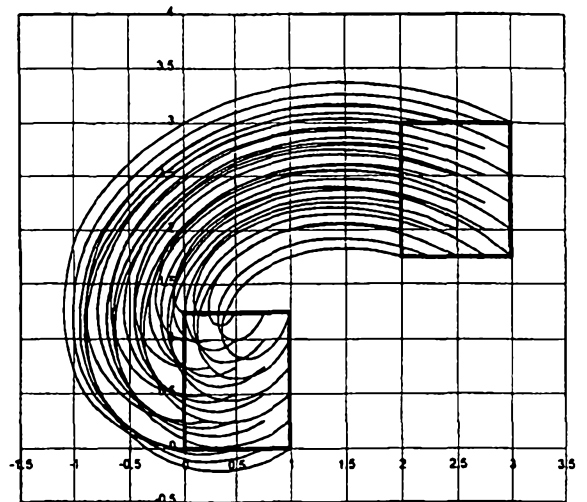
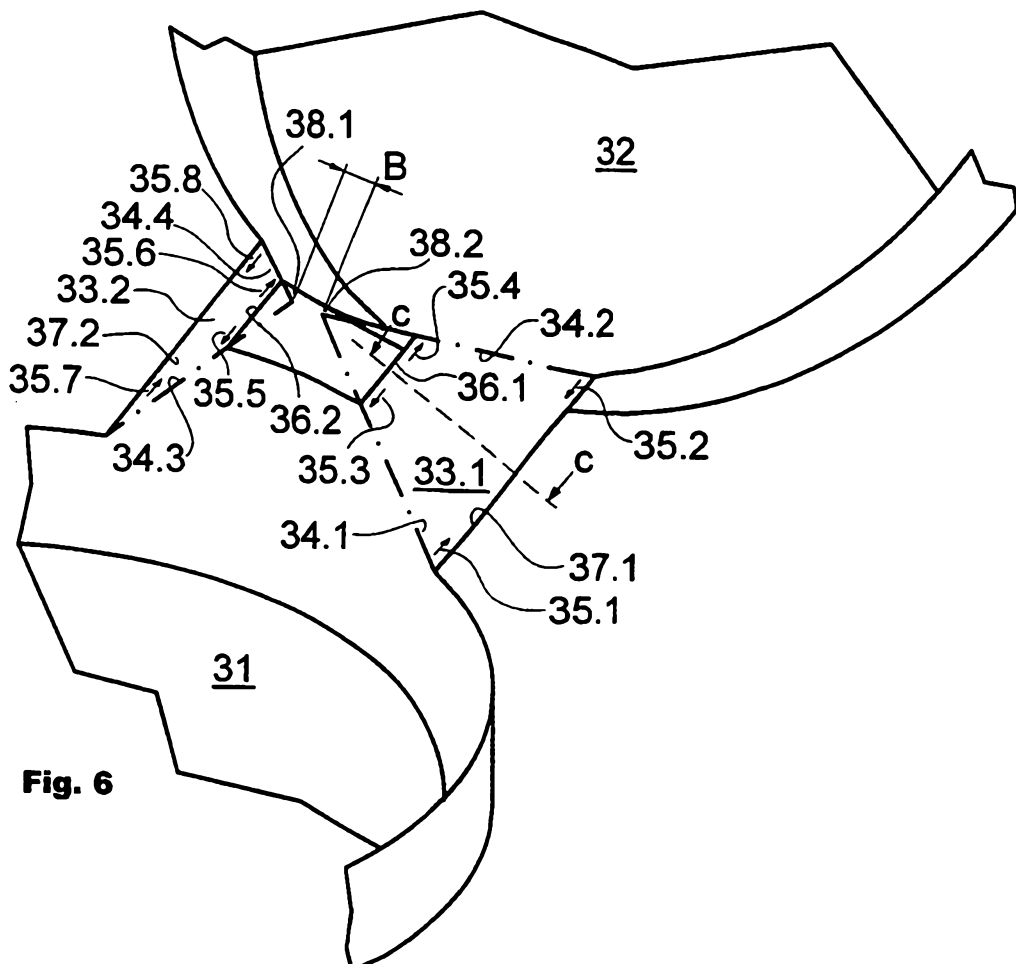
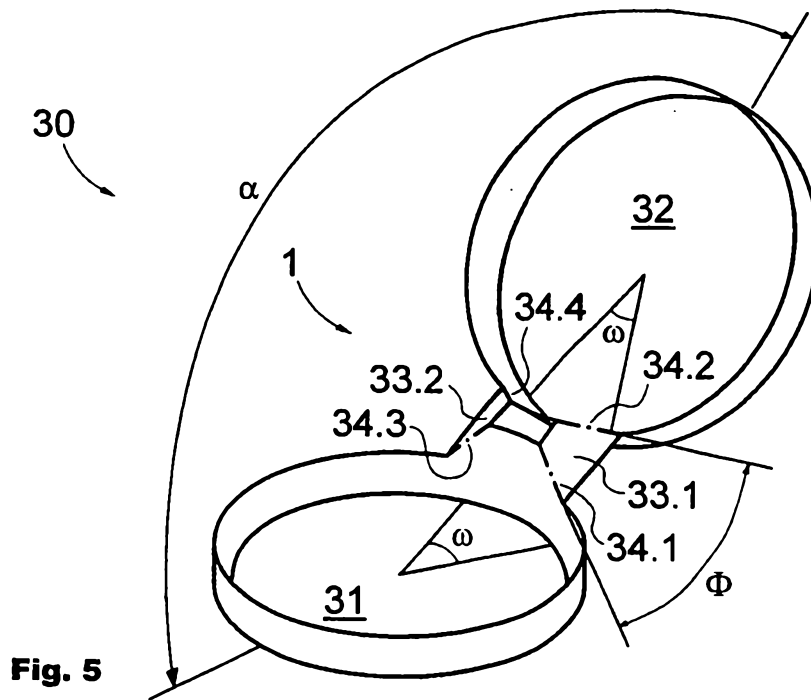

Fig. 4c

37



4/7

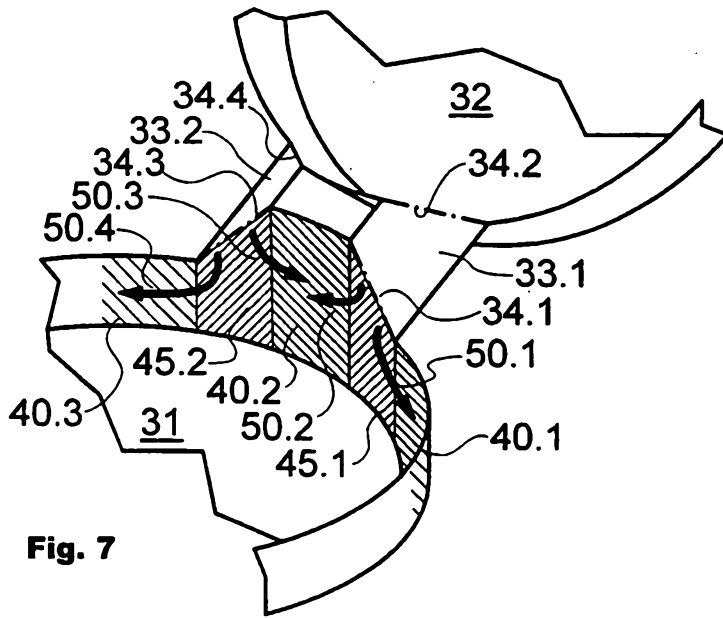

Fig. 7

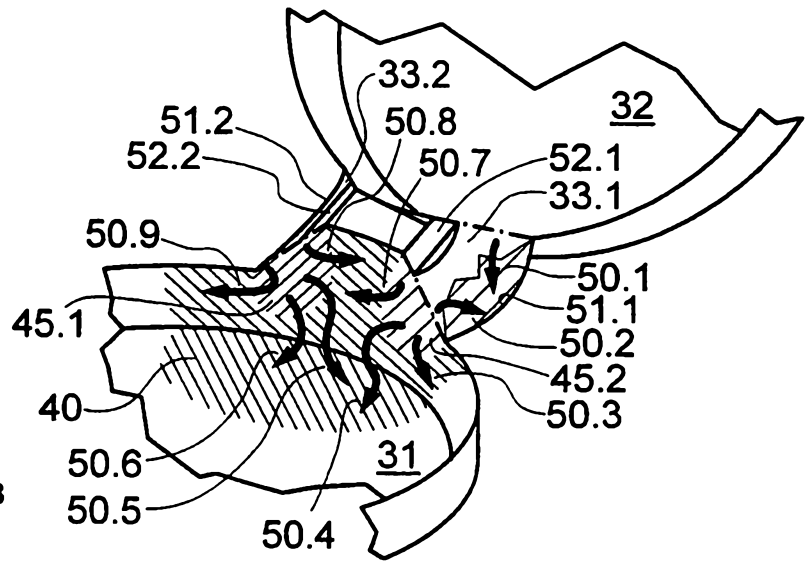

Fig. 8

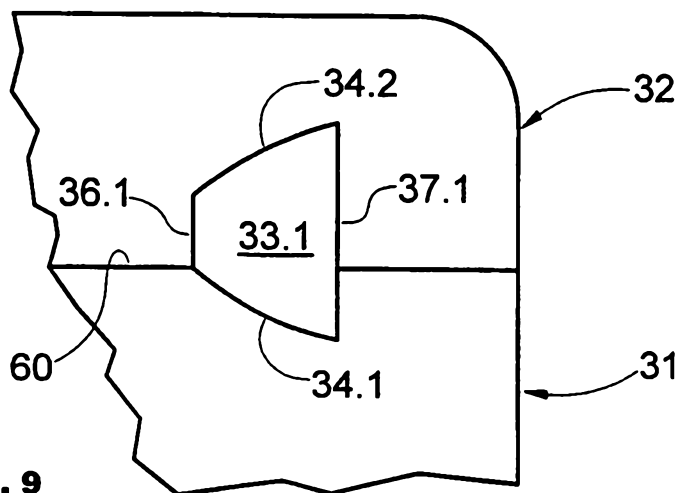
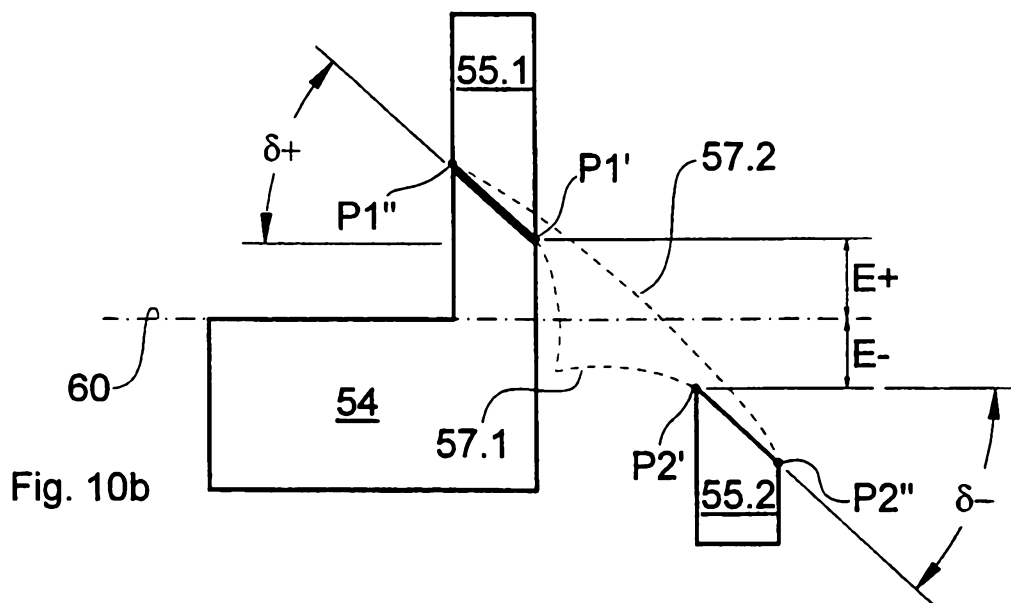
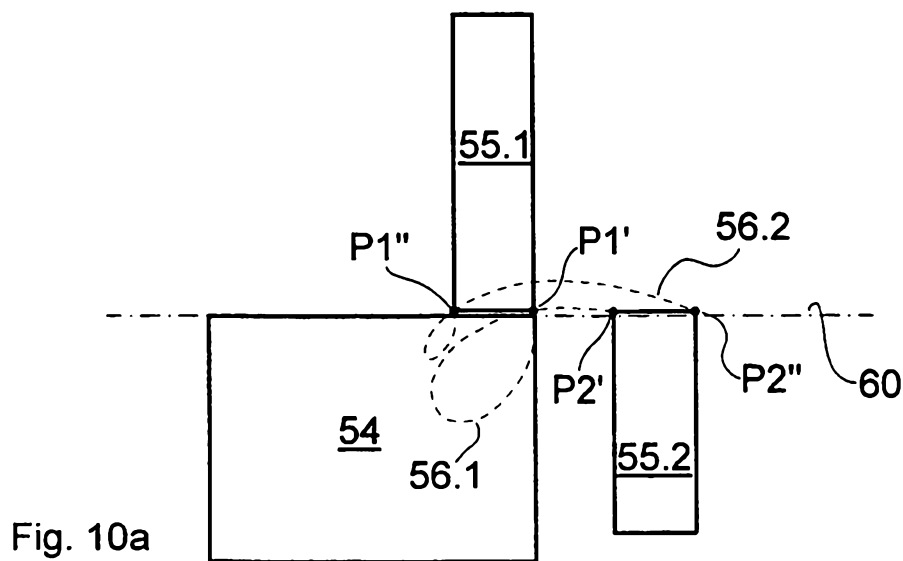

Fig. 9

5/7



6/7

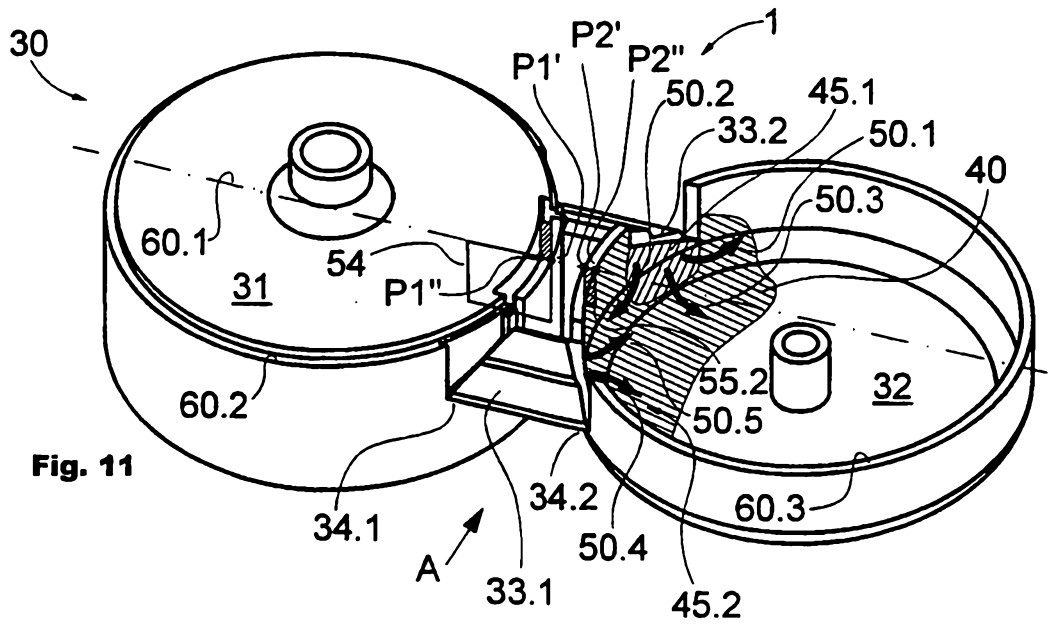

Fig. 11

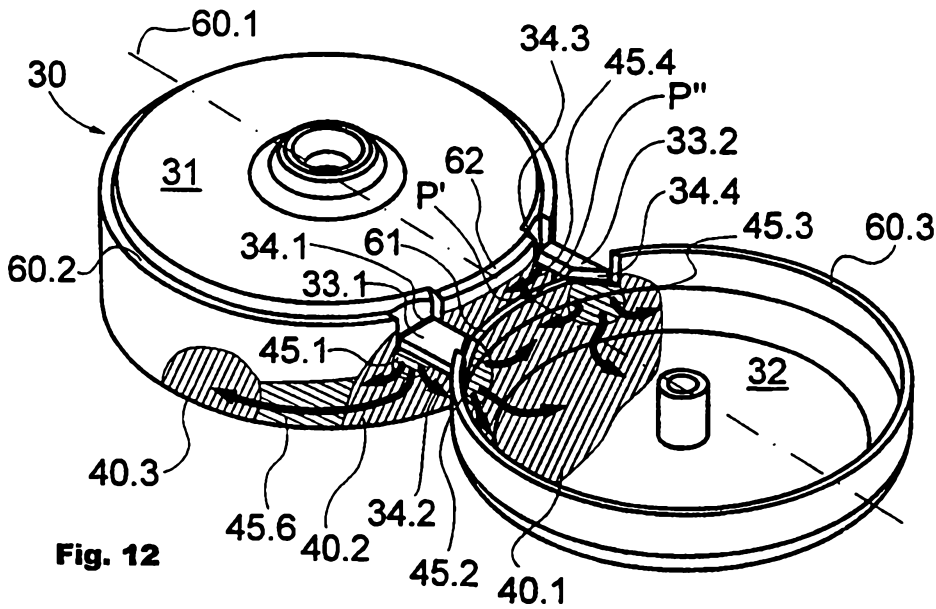

Fig. 12

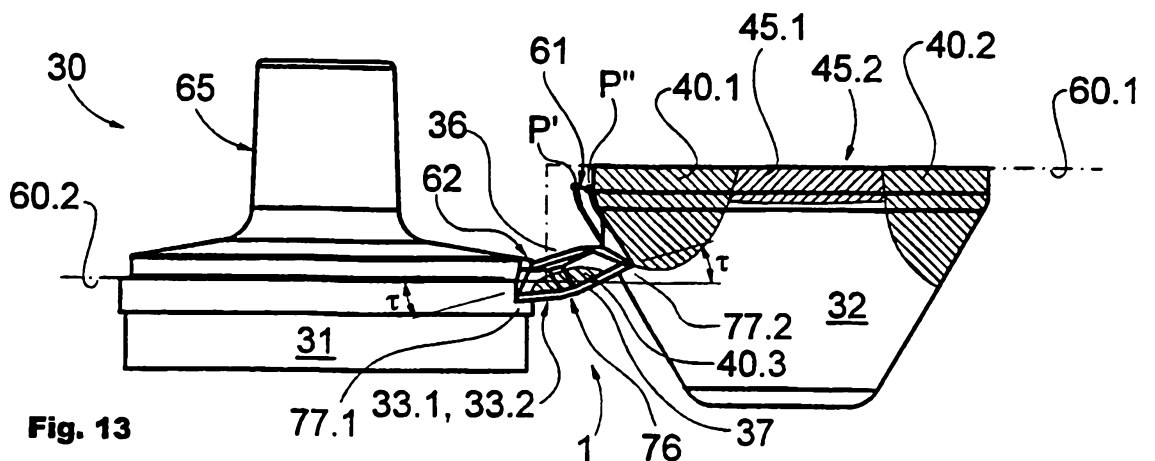

Fig. 13

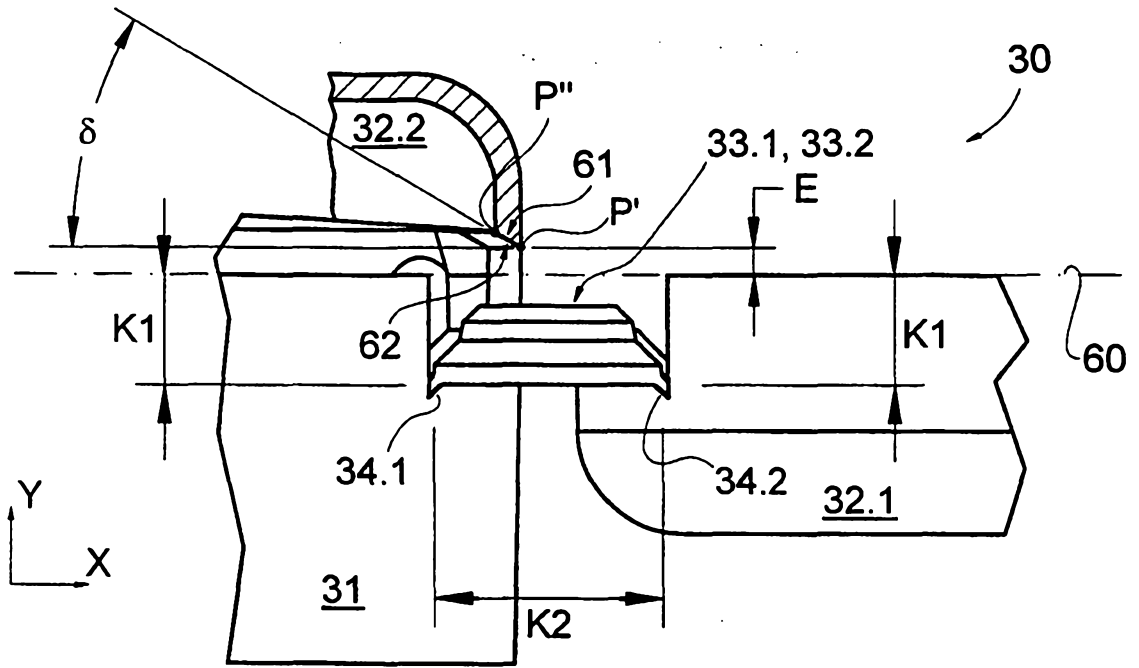

Fig. 14

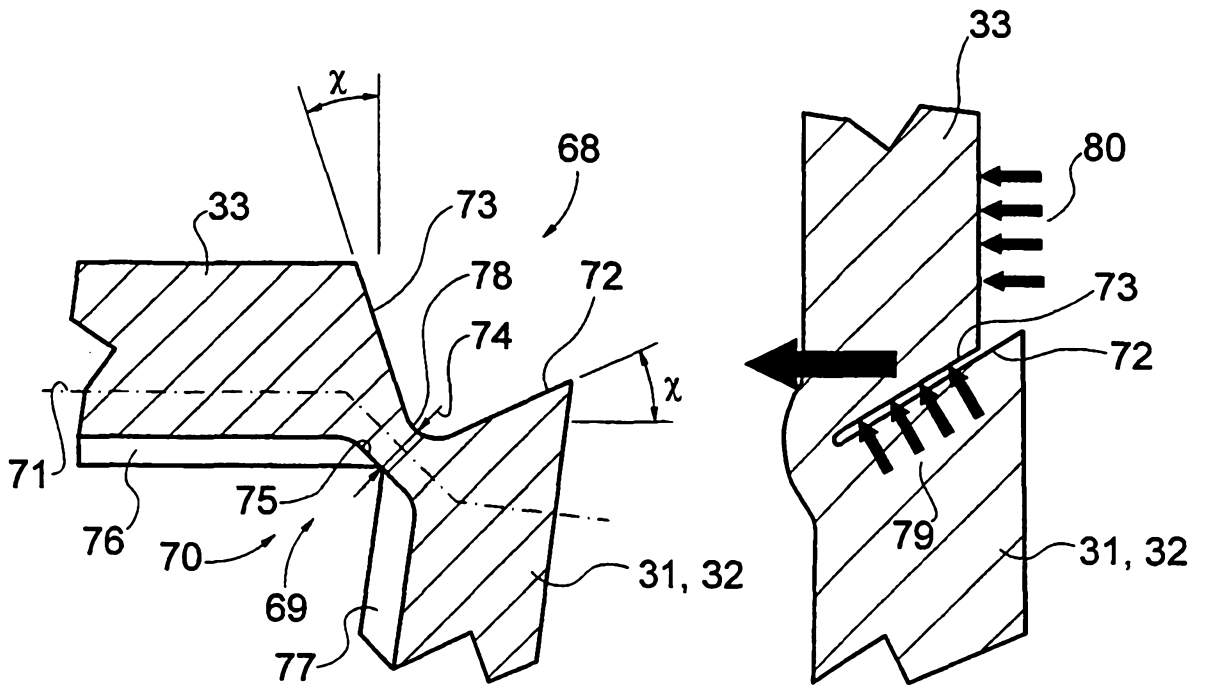

Fig. 15a

Fig. 15b