

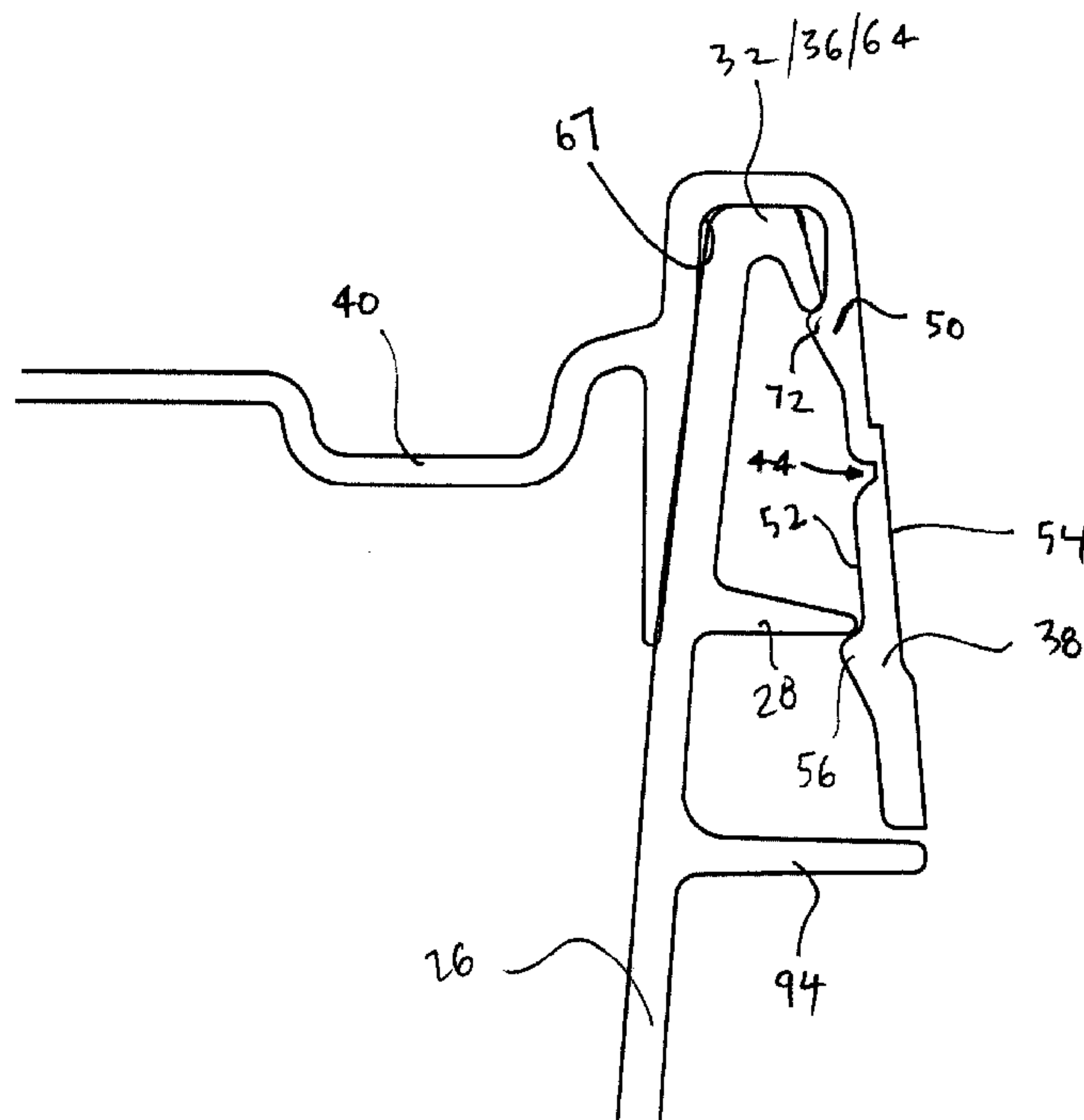

(22) Date de dépôt/Filing Date: 2002/05/17
(41) Mise à la disp. pub./Open to Public Insp.: 2003/06/19
(30) Priorités/Priorities: 2001/12/19 (60/340,842) US;
2002/02/15 (2,372,275) CA

(51) Cl.Int.⁷/Int.Cl.⁷ B65D 43/08, B65D 55/06
(71) Demandeur/Applicant:
TOP GRADE MOLDS LTD., CA
(72) Inventeur/Inventor:
CICCONE, VINCE, CA
(74) Agent: RIDOUT & MAYBEE LLP

(54) Titre : CONTENANT A COUVERCLE A CHARNIERE MUNI D'UNE BANDE DE DECHIRURE
(54) Title: CONTAINER WITH HINGED LID HAVING TEAR-OFF STRIP



(57) **Abrégé/Abstract:**

A container is disclosed and includes: a container body having an open end bounded by a thickened rim having a linear part defining a pintle; a container flange extending around the container body in spaced relation to the rim; a lid body overlying the rim in a closed position and having a channel which includes a linear part defining a socket and having a concave wall extending in close-fitting relation through greater than 180 degrees of the circumferential extent of the pintle around an axis defined thereby to hingably couple the lid body to the container body; and a skirt detachable from the lid body, extending therefrom in surrounding relation to the container flange and having a lid flange which extends around and grips the underside of the container flange such that, upon such detachment, the lid body is pivotally movable to an open position apart from the open end.

ABSTRACT OF THE DISCLOSURE

A container is disclosed and includes: a container body having an open end bounded by a thickened rim having a linear part defining a pintle; a container flange extending around the container body in spaced relation to the rim; a lid body overlying the rim in a closed position and having a channel which includes a linear part defining a socket and having a concave wall extending in close-fitting relation through greater than 180 degrees of the circumferential extent of the pintle around an axis defined thereby to hingably couple the lid body to the container body; and a skirt detachable from the lid body, extending therefrom in surrounding relation to the container flange and having a lid flange which extends around and grips the underside of the container flange such that, upon such detachment, the lid body is pivotally movable to an open position apart from the open end.

CONTAINER WITH HINGED LID HAVING TEAR-OFF STRIP

FIELD OF THE INVENTION

This invention relates to plastic lidded containers.

BACKGROUND OF THE INVENTION

In plastic lidded containers, it is desirable to provide a strong attachment and good seal between the container and the lid, especially for shipping purposes. Usually, interlocking or inter-engaging flanges are provided respectively on the lid and the upper peripheral edge portion of the container to retain the lid on the container. The difficulty is that the stronger the engagement between these interlocking flanges, and thus the stronger the attachment of the lid to the container, the more difficult it is to remove the lid when it is desired to do so. Ideally, one would like to have good engagement between the lid and the container for shipping purposes, and some means for relieving or reducing the force of engagement between the lid and the container when it is desirable to remove the lid.

One method of accomplishing the above objectives is to provide the lid with a tear-off strip that contains the lid locking flange that engages the container locking flange. When the lid is on the container, the engaged locking flanges hold the lid securely onto the container. When it is desired to remove the lid, the lid tear-off strip is removed, so there is no longer any locking engagement between the lid and the container.

However, while this method facilitates removal of the lid, it suffers to the extent that it does not provide for a secure fit between the lid and the container after the tear-off strip has been removed. As well, as there is no residual physical connection between the container and lid, the lid may need to be set down on a suitable surface for access to be gained to the contents of the container; this can result in the lid becoming soiled, whereupon the contents of the container can become contaminated, or on the surface becoming soiled with the contents of the

container.

One method of overcoming the former difficulty, namely, for providing a secure fit between the lid and container after removal of the tear-off strip is shown in United States Patent No. 4,735,337 issued to John W. Von Holdt. In this patent, the lid outer skirt that contains the lid locking flange is provided with a zigzag tear line that defines a tear-off strip. The tear line passes repeatedly through the lid locking flange, so that upon removal of the tear-off strip, only spaced-apart portions of the lid locking flange remain.

As to the latter difficulty, it will be evident that, in the case of a rectangular lid having two parts separated by an integral hinge (ie a linear portion formed of flexible material), if the lid locking flange is retained along a first of said parts, and intermittently along a second of said parts (for example, by the Von Holdt method), the first part will be relatively securely fastened to the container, while the second is relatively easily hingedly removed, to permit access to the contents. However, *inter alia*, this method suffers in that, in order to provide for secure fastening, the first part must block at least a portion of the container opening.

SUMMARY OF THE INVENTION

In the present invention, a container and a lid are provided. The container includes a hollow container body and a container locking flange. The container body has a thickened rim and an open end bounded by the rim. The rim defines a periphery of the container body and has a linear part. The linear part of the rim defines a pintle, and the pintle defines a pintle axis. The container locking flange is rigidly connected to the container body and peripherally extends around the exterior thereof in spaced relation to the rim. The lid includes a lid body and a peripheral skirt. The lid body overlies the rim in a closed position and has a channel formed therein which includes a linear part. The linear part of the channel defines a socket and has a concave wall that extends in close-fitting relation through greater than 180 degrees of the circumferential extent of the pintle around the pintle axis to hingably couple the lid body to the container body for movement from the closed position to

an open position where the lid body is disposed at an angle to the open end of the container. The peripheral skirt is detachably connected to the lid body and extends therefrom in surrounding relation to the container locking flange. The skirt has an inwardly-disposed lid locking flange which extends peripherally around the container body and grips the underside of the container locking flange to prevent removal of the lid body from the container body. Upon detachment of the skirt, the lid body is pivotally movable between the closed position and the open position.

Other advantages, features and characteristics of the present invention, as well as methods of operation and functions of the related elements of the structure, will become more apparent upon consideration of the following description with reference to the accompanying drawings, the latter of which being briefly described hereinbelow.

BRIEF DESCRIPTION OF THE DRAWINGS

A preferred embodiment of the invention will now be described, by way of example, with reference to the accompanying drawings, in which:

Figure 1 is a front, top perspective view of apparatus according to a preferred embodiment of the present invention;

Figure 2 is a view similar to Figure 1, showing a skirt of the lid partially removed;

Figure 3A is a view similar to Figure 1, with the skirt completely removed;

Figure 3B is a rear, top perspective view of the container of Figure 1, with the skirt completely removed;

Figure 4A is a view similar to Figure 3A, with the lid body pivoted relative to the container body;

Figure 4B is a view similar to Figure 3B, with the lid body pivoted relative to the container body;

Figure 5 is a top view of the structure of Figure 1;

Figure 6 is a partial cross-sectional view of the structure of Figure 1, viewed along line 6-6 in Figure 5;

Figure 7 is a partial cross-sectional view of the structure of Figure 1, viewed along line 7-7 in Figure 5;

Figure 8 is an exploded perspective view of the structure of Figure 1;

Figure 9 is a view along arrow 9 of Figure 8;

Figure 10 is a view along arrow 10 of Figure 8;

Figure 11 is a top view of the structure of Figure 3A;

Figure 12 is partial cross-sectional view along line 12-12 of Figure 11;

Figure 13 is a partial cross-sectional view along line 13-13 of Figure 11;

Figure 14 is a view similar to Figure 13, showing the lid body pivoted relative to the container body; and

Figure 15 is a view similar to that of Figure 14 of an alternative embodiment of the lid of the invention in a 90 degree open position.

DETAILED DESCRIPTION OF THE PREFERRED EMBODIMENT

In the description below, like reference numerals are used to indicate components which are similar in the various embodiments of the present invention.

Primed reference numerals are used to indicate different variants of the similar components. Referring to Figure 1, a preferred embodiment of the present invention is generally designated by reference numeral 20 and comprises a container 22 and a lid 24, the structures of which parts will firstly be described.

As best illustrated in Figure 8, the container 22 includes a hollow container body 26 (actually, a substantially square bucket in the preferred embodiment) and a container locking flange 28.

The container body 26 has a thickened rim 32 and an open end 34 bounded by the rim 32. The rim 32 defines a periphery 33 of the container body 26 and includes a linear part 36 which defines a pintle 64. The pintle 64 itself defines a pintle axis A-A.

The container locking flange 28 is rigidly connected to the container body 26 and peripherally extends around the exterior thereof in spaced relation to the rim 32. In the preferred embodiment illustrated, the container locking flange 28 is formed integrally with the container body 26.

As illustrated in Figure 8, the lid 24 includes a lid body 40 and a peripheral skirt 38.

The lid body 40 is illustrated in Figure 3A overlying the rim 32 (rim 32 not being visible) in a closed position. As best seen in Figure 9, the lid body 40 has a channel 46 formed therein which includes a linear part 42. The linear part 42 defines a socket 66 and has a concave wall 67 best seen in Figure 14 that extends, in close-fitting relation through greater than 180 degrees of the circumferential extent of the pintle 64 around the pintle axis A-A to hingably couple the lid body 40 to the container body 26, as discussed more fully in following paragraphs.

Skirt 38 is detachably connected (in the preferred embodiment, it is a tear-off strip, as discussed more fully in following paragraphs) to lid body 40 and extends

therefrom in surrounding relation to the container locking flange 28, as indicated in Figure 7. The skirt 38 has an inwardly-disposed lid locking flange 56 which extends peripherally around the container body 26 and grips the underside of the container locking flange 28 to prevent removal of the lid body 40 from the container body 26, also as seen in Figure 7. As this general type of container is typically assembled by applying high forces to the respective parts and urging same together, by press or the like, it will be appreciated by persons of ordinary skill in the art that, typically, at least the corners of the lid 24 will be relieved, by the omission of sections of the lid locking flange 56, and the lid 24 and the container 22 will be constructed out of a suitable resilient material, such as polyethylene or polypropylene, thereby to permit same to be press-fit together, using conventional techniques.

In any event, it will be evident that the foregoing elements alone provide a useful structure in that, for shipping, the invention can be used with skirt 38 connected to the lid body 40 (as shown *inter alia* in Figure 1), with reasonable assurance that, under normal handling conditions, the lid body 40 and container body 26 will not become separated and spill any goods contained therein, while providing an ability, when access to the contents is required, for the detachment of the skirt 38 (as indicated by the sequence of Figures 1, 2 and 3A), whereupon the lid body 40 may be pivoted about the pintle axis A-A from the closed position shown in Figures 3A, 3B and 13 to an open position, shown in Figures 4A, 4B and 14, where the lid body 40 is disposed at an angle to the open end 34 of the container 22.

However, further features are also provided in the preferred embodiment.

As one further feature, the concave wall 67 is defined in part by one or more protruding hooked portions 58 which grip the underside of the linear part 36 of the rim 32 (actually, two spaced-apart hooked portions), as best illustrated in Figure 9 and Figure 13. (Hooked portions 58 are also indicated in phantom outline in Figures 4A and 8).

Additionally, the linear part 36 of the rim 32 has formed thereon, for each protruding hooked portion 58, a necked-in or chamfer portion 68, as best illustrated in Figure 8, in which the hooked portions 58 travel during assembly. As seen in Figure 14, wherein a surface 69 of a respective necked-in portion 68 is shown, the necked-in portion 68 tapers in width towards the upper extent of the rim 32, thereby to lessen the forces that would otherwise need be applied during assembly and facilitate insertion of the linear part 36 of the rim 32 within the linear part 42 of the channel 46. Surface 69 is shown in phantom outline in Figure 12.

As aside, it will be noted that, in the preferred embodiment illustrated, the rim 32 is substantially rectangular (actually substantially square) and thus has four linear parts 36 as shown in Figure 10. Similarly, the lid body 40 is substantially square, with the socket 66 aligned along one side thereof, as indicated in Figure 9. This also facilitates assembly, to the extent that there is no dedicated pintle, but rather, any one of said linear parts 36 may define the pintle and be disposed within socket 66, thereby obviating the need for the lid 24 and the container 22 to be aligned in any particular directionality prior to assembly.

As another feature of the preferred embodiment, the rim 32 is disposed substantially entirely within the channel 46. That is, channel 46 extends around the lid body 40, as shown in Figure 9, thereby to define a tubular part 50 to which is detachably connected the skirt 38, as seen in Figure 6 and 7. In the preferred embodiment, the lid body 40 and the skirt 38 are formed integrally, and divided by a peripheral groove 44 which can be formed on the inside surface 52, as seen in Figure 6, on the outside surface 54 or partly on both.

As another feature, the lid body 40 is formed with a lid locking flange 72 adjacent to the channel 46. In the preferred embodiment, flange 72 projects inwardly from the tubular part 50 of the lid body 40, is located on the side of the lid body 40 opposite to that with which the socket 66 is aligned, as shown in Figure 9, and grips the underside of the rim 32 to resist removal of the rim 32 from the channel 46, as indicated, *inter alia*, by Figure 12. This provides for a positive closure between the lid body 40 and the container body 26 even following detachment of the skirt 38. The relative size, spacing and position of the lid locking flange 72 can be configured as desired to give desired levels of positive closure. For clarity, lid

locking flange 72 is shown in phantom outline in Figure 4B.

The tubular part 50 of the lid body 40 of the preferred embodiment is also formed with triangularly shaped thin membrane windows 74 therein, as best indicated in Figures 3B and 4B, wherein the membrane windows 74 are indicated in phantom outline. Membrane windows 74 are located on either side of the lid locking flange 72, bordering on the peripheral groove 44, so that upon removal of skirt 38 the windows 74 turn into downwardly disposed V-shaped, weakened areas on either side of the lid locking flange 72. This portion of the tubular part 50 (ie located between the windows 74) thus becomes a flap 76 that can be pried outwardly and upwardly to release the lid locking flange 72 from the rim 32 and thus allow for pivotal disengagement of the lid body 40 from the container body 26. The thin membrane windows 74 can stretch elastically and act as springs to help return flap 76 to its original (locking) position. The membranes of windows 74 typically are about 0.2 to 0.5 mm (0.008 to 0.020 inches) thick. In the preferred embodiment, membrane windows 74 have reinforcing ribs 78 (also indicated in phantom outline in Figure 4B). This minimizes the likelihood that the membranes 74 will tear upon the lifting of the flap 76, and also facilitates the return of flap 76 to its original shape.

As yet another feature of the preferred embodiment, the outer surface 80 of the lid body 40 corresponding to the position of the lid locking flange 72 includes indicator means 82 which indicate where flap 76 is located. The indicator means 82 of the preferred embodiment comprises a recessed portion which includes arrows 84 pointing upwardly, as shown in Figures 3B and 4B.

Shown in Figure 15 is a further embodiment of the lid wherein the tubular part 50' extending from the linear part 42, is shorter relative to that of the embodiment shown in Figures 1 to 14. In the embodiment of Figure 15, once the skirt 38 is removed in the manner discussed below, shortened tubular part 50' allows the lid to be opened more fully than the embodiment of the lid shown in Figure 14. For example, in the embodiment shown in Figure 15, the lid may open to a position 90 degrees above the plane of the closed lid. Preferably, when the lid is in this 90

degree open position, an end portion 51 of tubular part 50' is sized to contact the outer surface 41 of the container body 26 in press fit engagement, thereby providing releasable support for the lid in this 90 degree open position. It should be understood that the length of the tubular part 50' may be adjusted for press fit engagement with the outer surface 41 of the container body corresponding to different angles of opening of the lid. As seen in Figure 15, shown by example, the outer surface 69' of the necked portion 68' may be rounded to promote easy pivoting to the 90 degree open position, however it should be understood that surface 69' may also be of comparable shape to surface 69 of Figure 14 (i.e. tapering in width toward the upper extent of the rim).

To facilitate its removal, the skirt 38 of the preferred embodiment is also formed with a window 90 spaced from the lower peripheral edge 86 of the skirt 38, and a reduced thickness portion 88 extending between lower peripheral edge 86 and window 90, as illustrated in Figure 1. To detach skirt 38, one can insert a tool such a screwdriver into window 90 and pry skirt 38 outwardly to break the reduced thickness portion 88. This provides a tab portion 92 of skirt 38, shown in Figure 2, that can be grasped and pulled outwardly to tear skirt 38 from tubular part 50 along peripheral groove 44.

It will be appreciated that breaking reduced thickness portion 88 is a tamper evidence feature for lid 24. Tamper-resistance is also provided for by the inclusion of barrier flange 94 which, as shown in Figure 7 extends peripherally about container body 26 beneath the container locking flange 28, at the base of the skirt 38, to restrict the ability of persons to pry the lid 24 from the container body 26.

It will also be understood that various changes in size, shape and arrangement of parts can be made without departing from the spirit or scope of the invention. Accordingly, it is to be understood that the scope of the present invention is limited only by the claims appended hereto, purposively construed.

I CLAIM:**1. Apparatus comprising:**

a hollow container body having a thickened rim and an open end bounded by the rim, the rim defining a periphery of the container body and having a linear part which defines a pintle, the pintle defining a pintle axis;

a container locking flange peripherally extending around the exterior of the container body in spaced relation to the rim and being rigidly connected to the container body;

a lid body overlying the rim in a closed position and having a channel formed therein which includes a linear part defining a socket, the linear part of the channel having a concave wall that extends in close-fitting relation through greater than 180 degrees of the circumferential extent of the pintle around the pintle axis to hingably couple the lid body to the container body for movement about the pintle axis from the closed position to an open position where the lid body is disposed at an angle to the open end of the container; and

a peripheral skirt detachably connected to the lid body and extending therefrom in surrounding relation to the container locking flange, the skirt having an inwardly-disposed lid locking flange which extends peripherally around the container body and grips the underside of the container locking flange to prevent removal of the lid body from the container body,

whereby, upon detachment of the skirt, the lid body is pivotally movable between the closed position and the open position.

2. Apparatus according to claim 1, wherein the concave wall includes one or more protruding hooked portions which grip the underside of the linear part of the rim during pivoting from said open to said closed position.
3. Apparatus according to claim 2, wherein the linear part of the rim has formed thereon, an outer, upwardly tapering necked-in portion to facilitate insertion of the linear part of the rim within the linear part of the channel during assembly.
5. Apparatus according to claim 4, wherein the concave wall includes a pair of spaced-apart said protruding hooked portions.
6. Apparatus according to claim 1, wherein the channel extends around the entirety of the circumference of the lid body, the lid body including a tubular part which defines in part the outer portion of the channel, with the skirt being detachably connected to the tubular part and the rim being positionable within the channel.
7. Apparatus according to claim 6, wherein the lid body is rectangular and includes a lid locking flange projecting inwardly from the tubular part, said lid locking flange gripping the underside of the rim to releasably resist removal of the rim from the channel when said rim is positioned within said channel.
8. Apparatus according to claim 7, wherein the lid body is rectangular and the socket is aligned along one side of the lid body.
9. Apparatus according to claim 7 or 8, wherein the lid locking flange is located on the side of the lid body opposite to that along which the socket is aligned.
10. Apparatus according to claim 2 wherein the channel extends around the entirety of the circumference of the lid body, the lid body including a tubular part which defines in part the outer portion of the channel, a portion of the tubular part extending below the protruding hooked portions, with the skirt

being detachably connected to the tubular part and the rim being positionable within the channel.

11. Apparatus according to any one of claims 6 to 10 wherein said tubular part is sized such that, an end portion of the tubular part extending from the linear part of the channel, is urged into press fit engagement with an outer surface of the container body as said lid body is rotated into said open position, thereby providing releasable support for the lid in said open position.
12. Apparatus according to claim 11 wherein the lid open position is 90 degrees about said pintle axis from said closed position.
13. Apparatus according to any one of claims 1 to 12, wherein the tubular part of the lid body and the skirt are formed integrally and divided by a peripheral groove.
14. Apparatus according to claim 13, wherein the tubular part of the lid body is formed with thin membrane windows therein on either side of the lid locking flange and bordering on the peripheral groove, so that detachment of the skirt leaves downwardly disposed thin membrane notches on either side of the lid locking flange.
15. Apparatus according to claim 14, wherein the thin membrane windows are formed with strengthening ribs therein.
16. Apparatus according to claim 16, wherein the lid body includes an outer surface, said outer surface including a recessed portion at the position of the lid locking flange, thereby indicating its location.

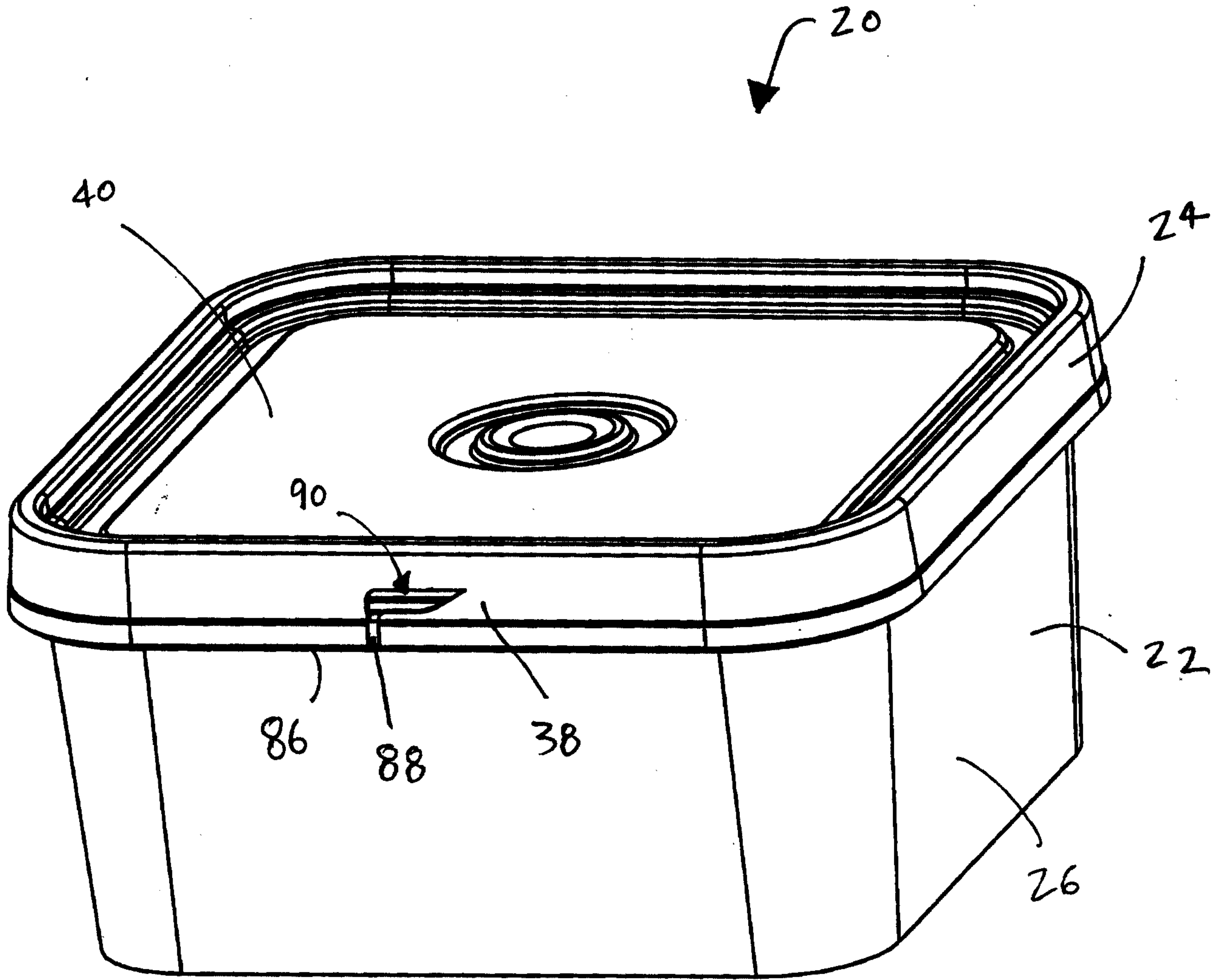

FIGURE 1

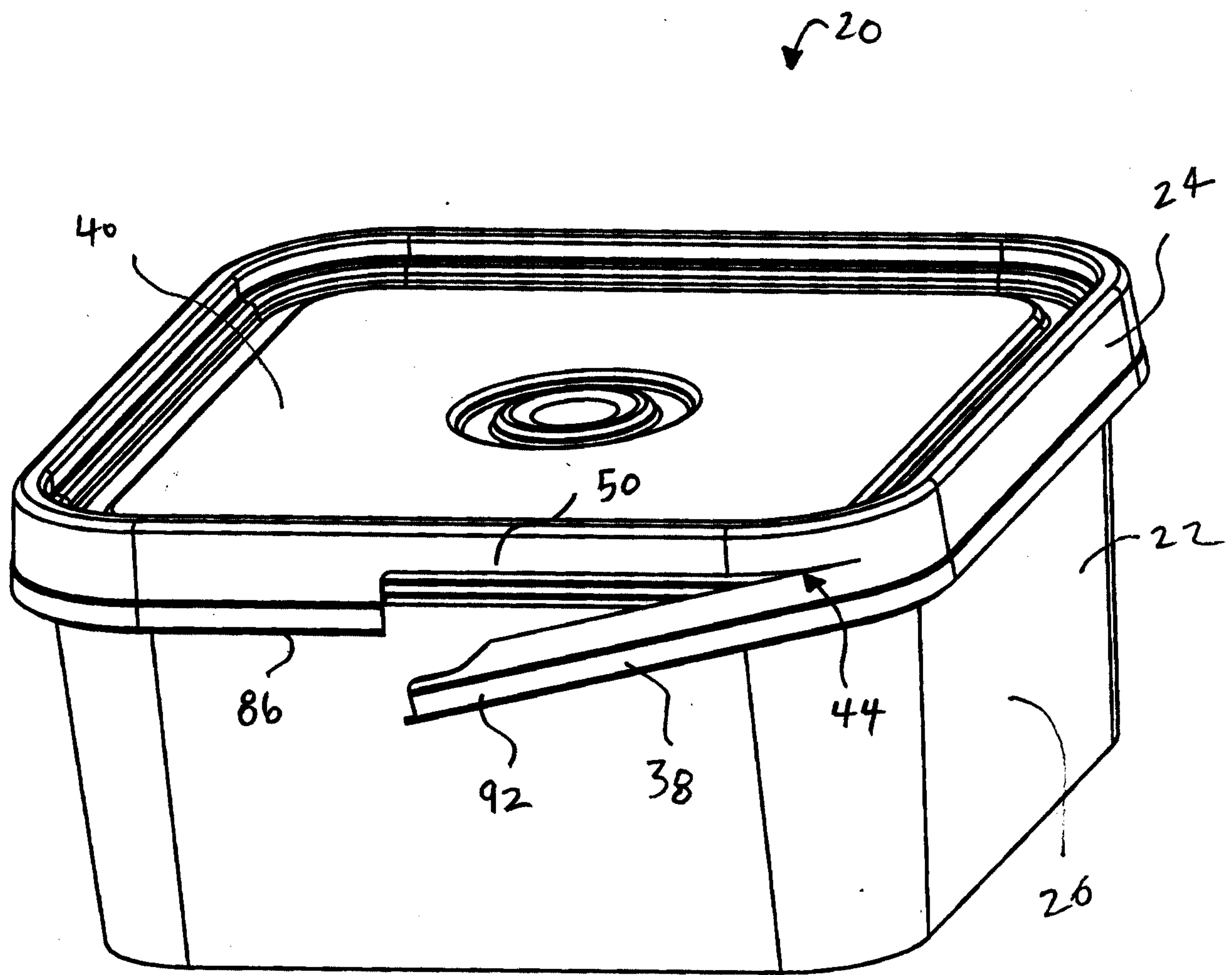

FIGURE 2

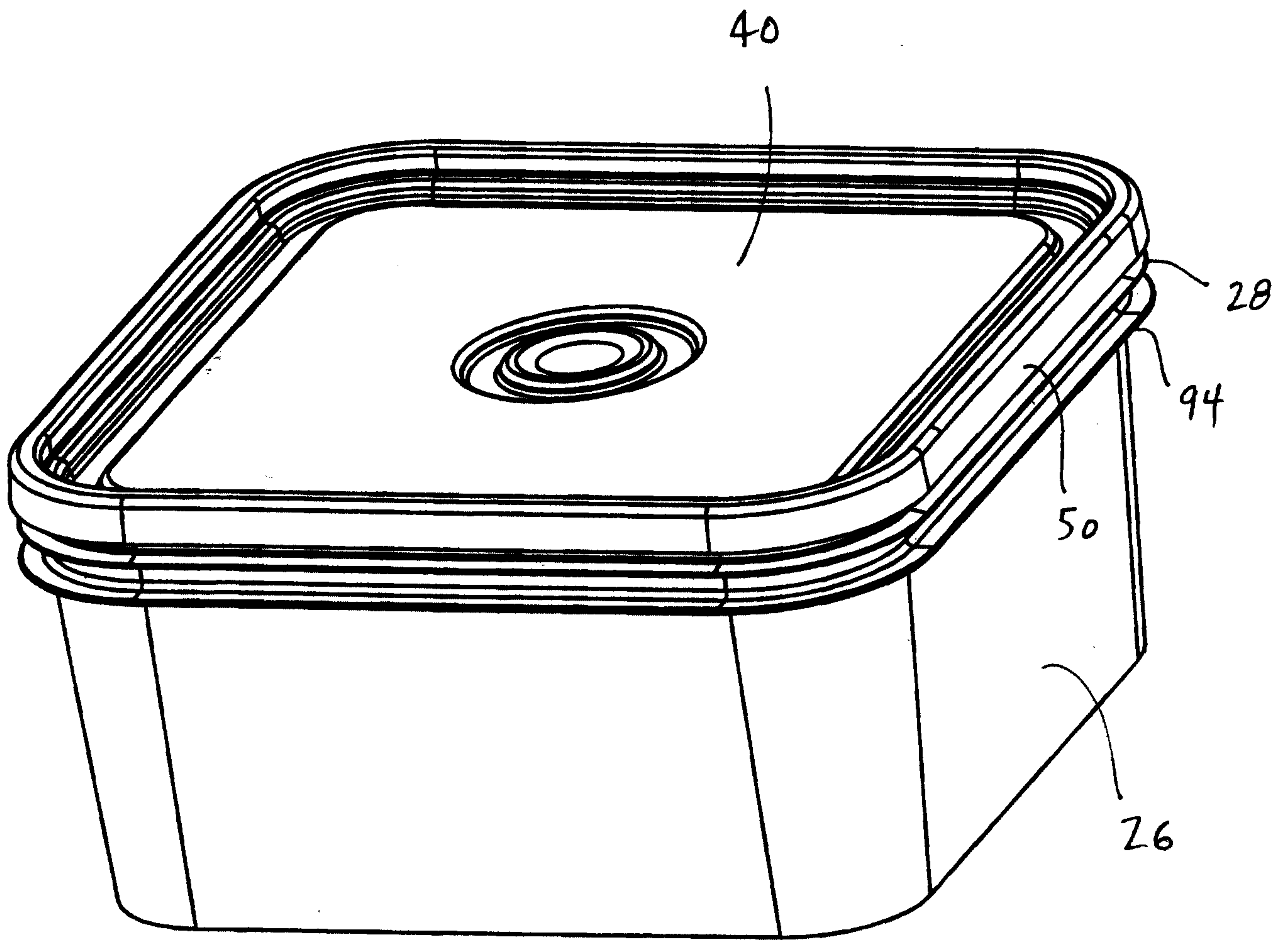

FIGURE 3A

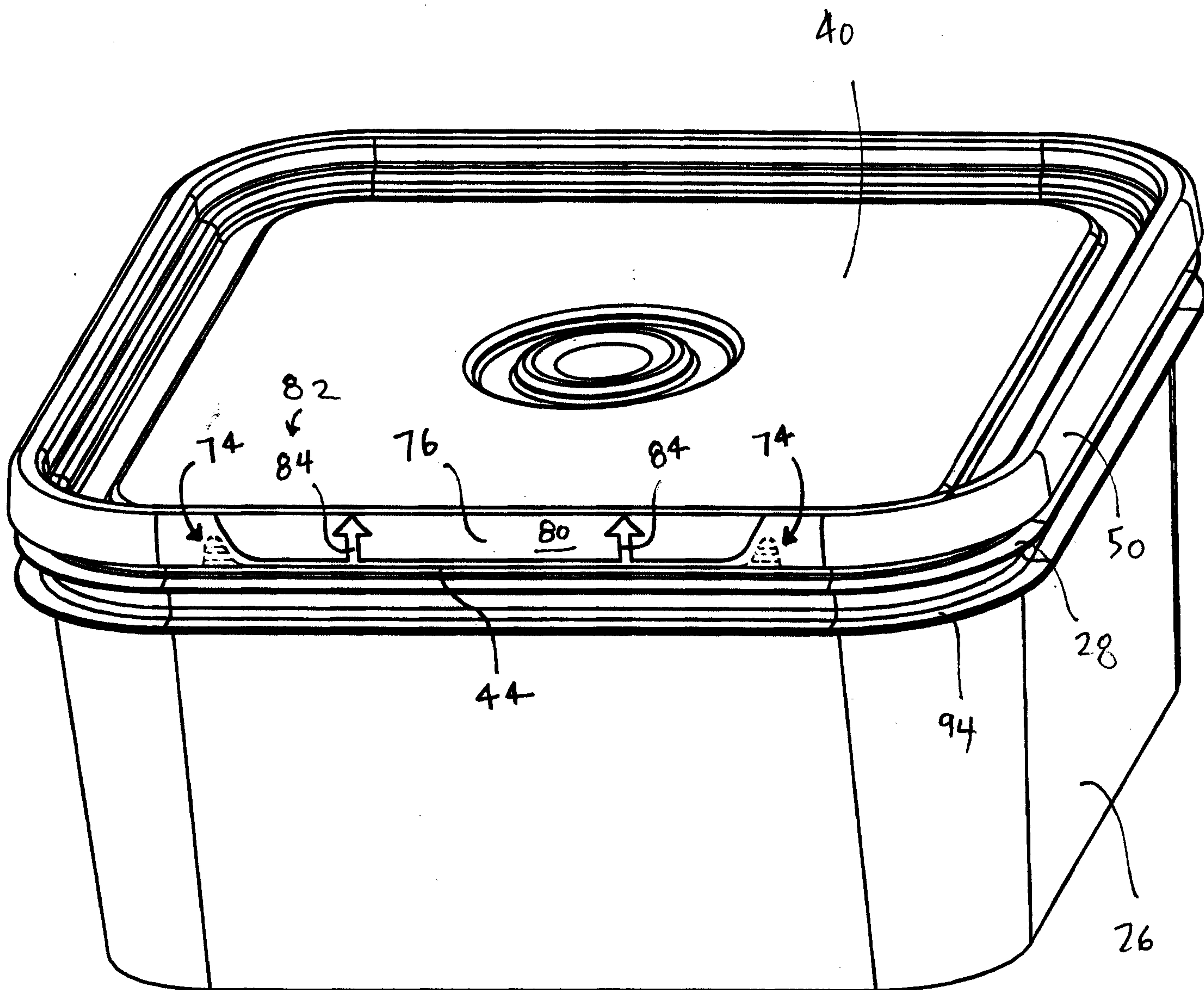

FIGURE 3B

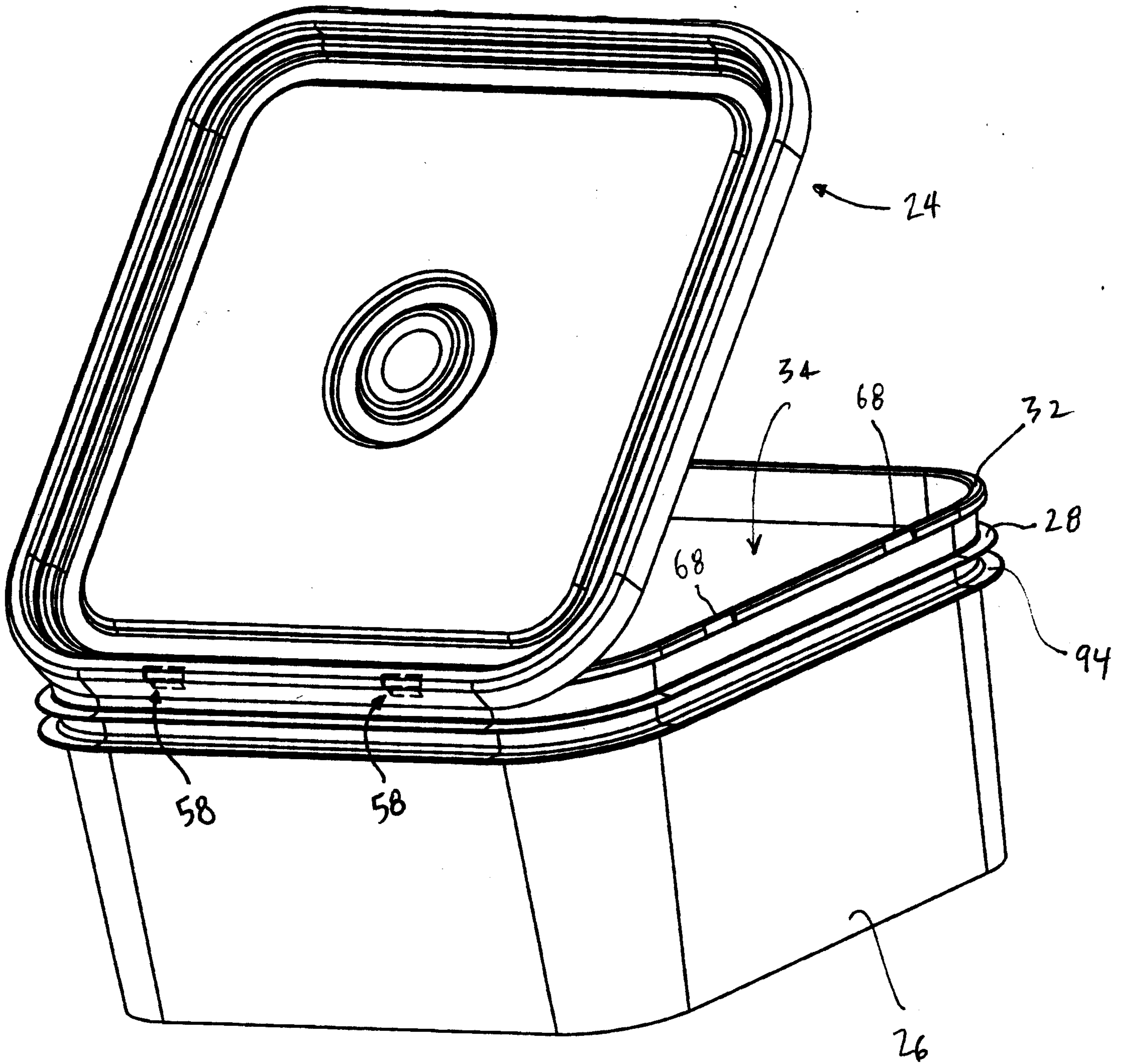

FIGURE 4A

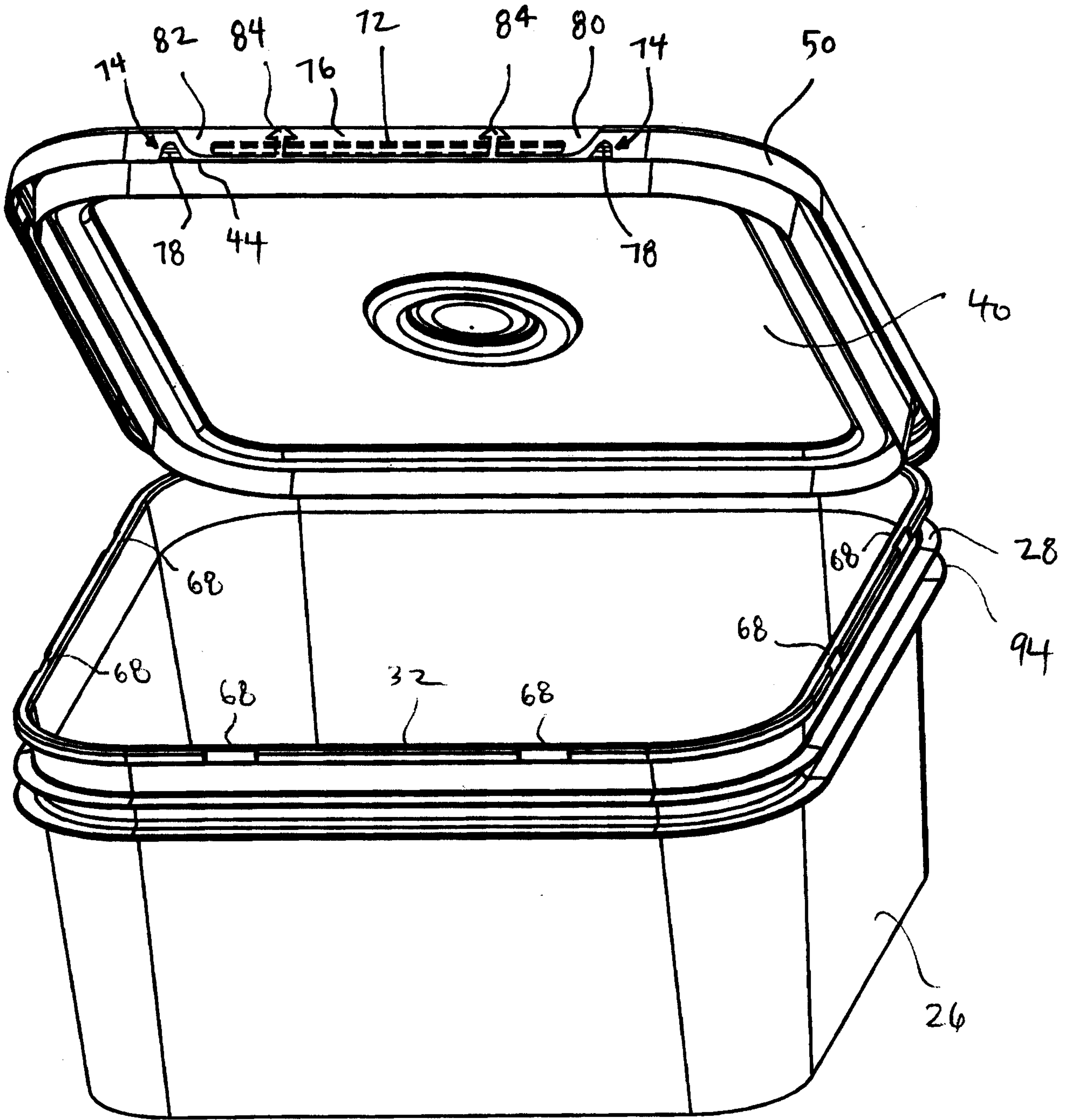

FIGURE 4B

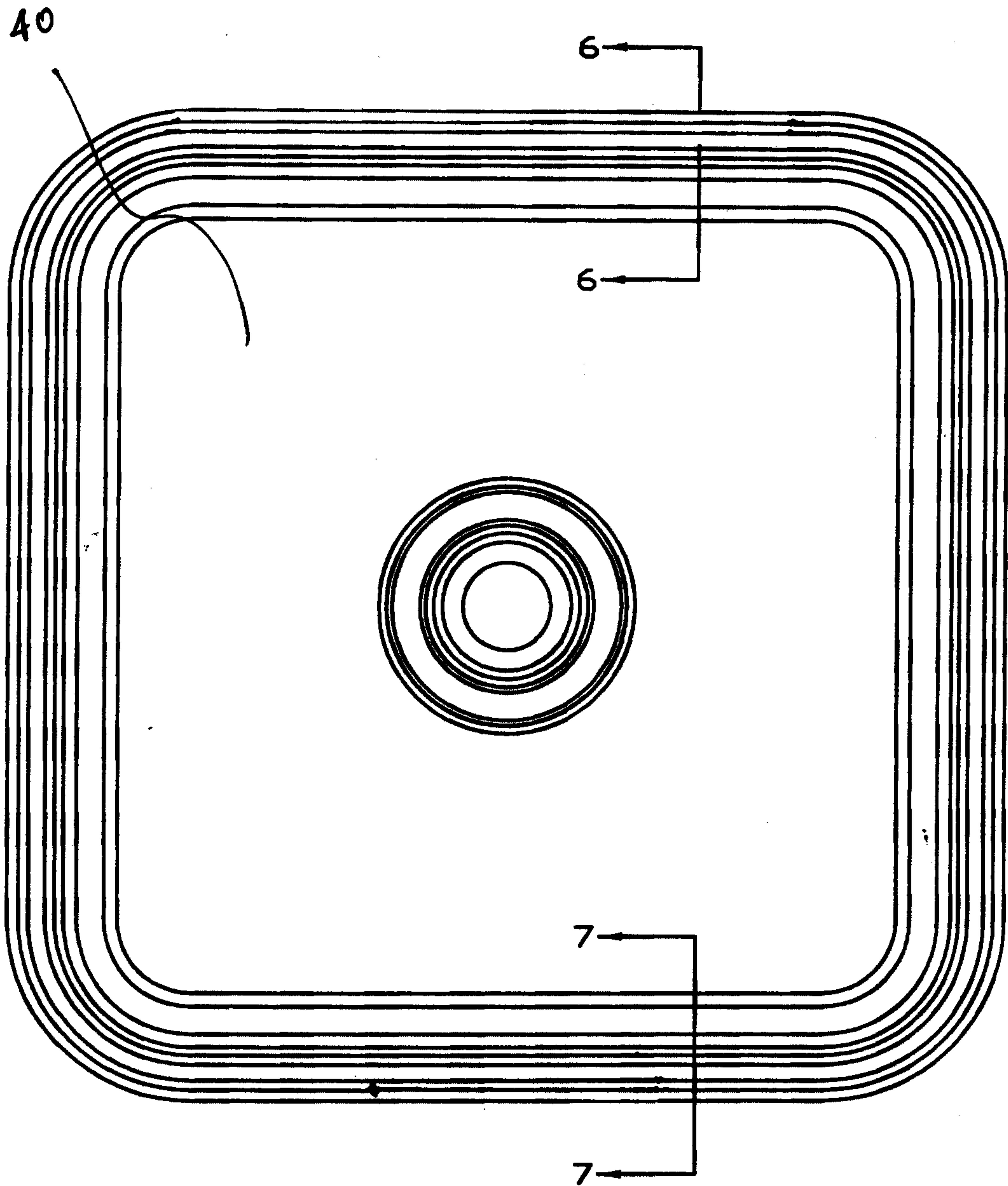

FIGURE 5

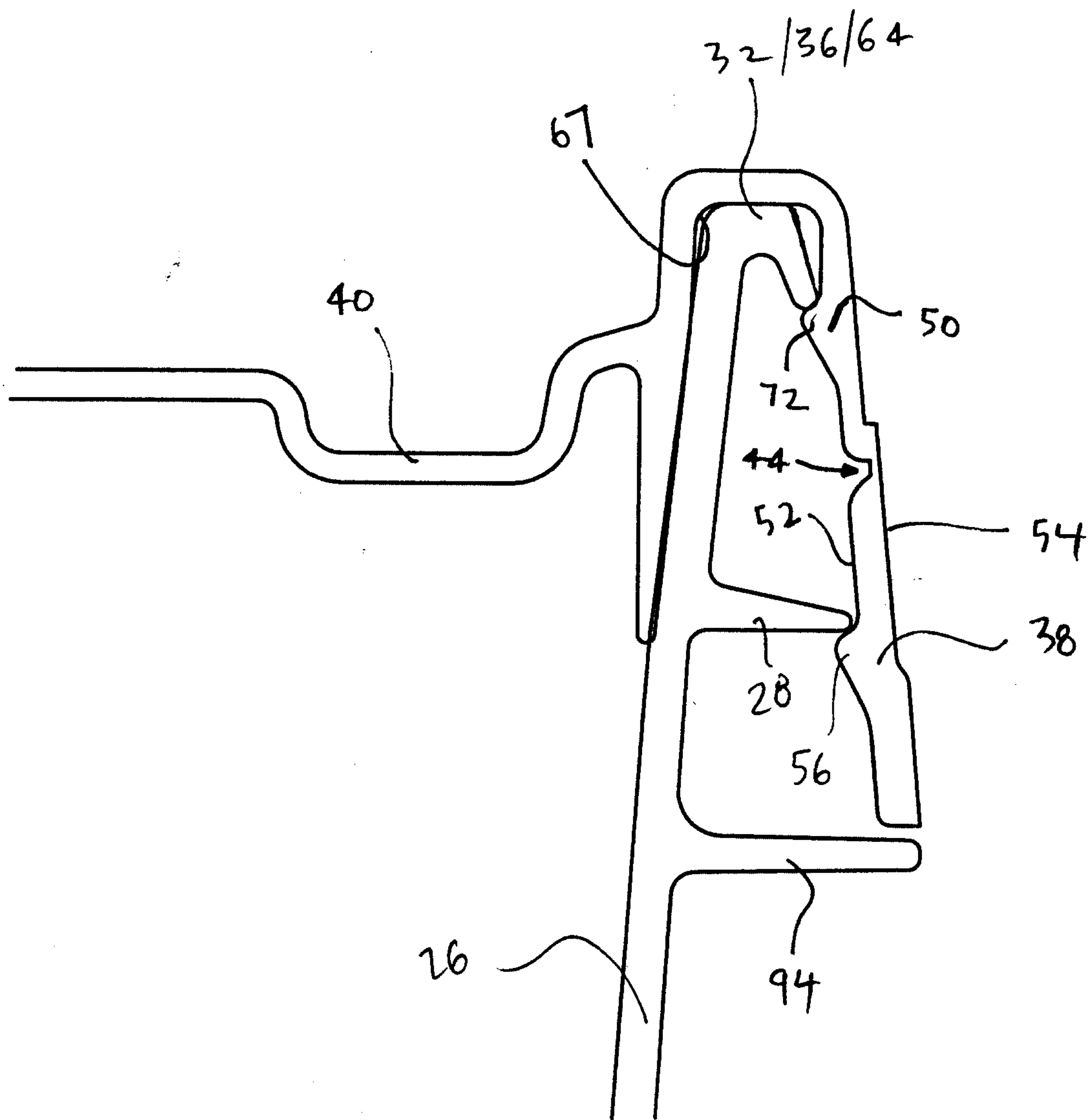

FIGURE 6

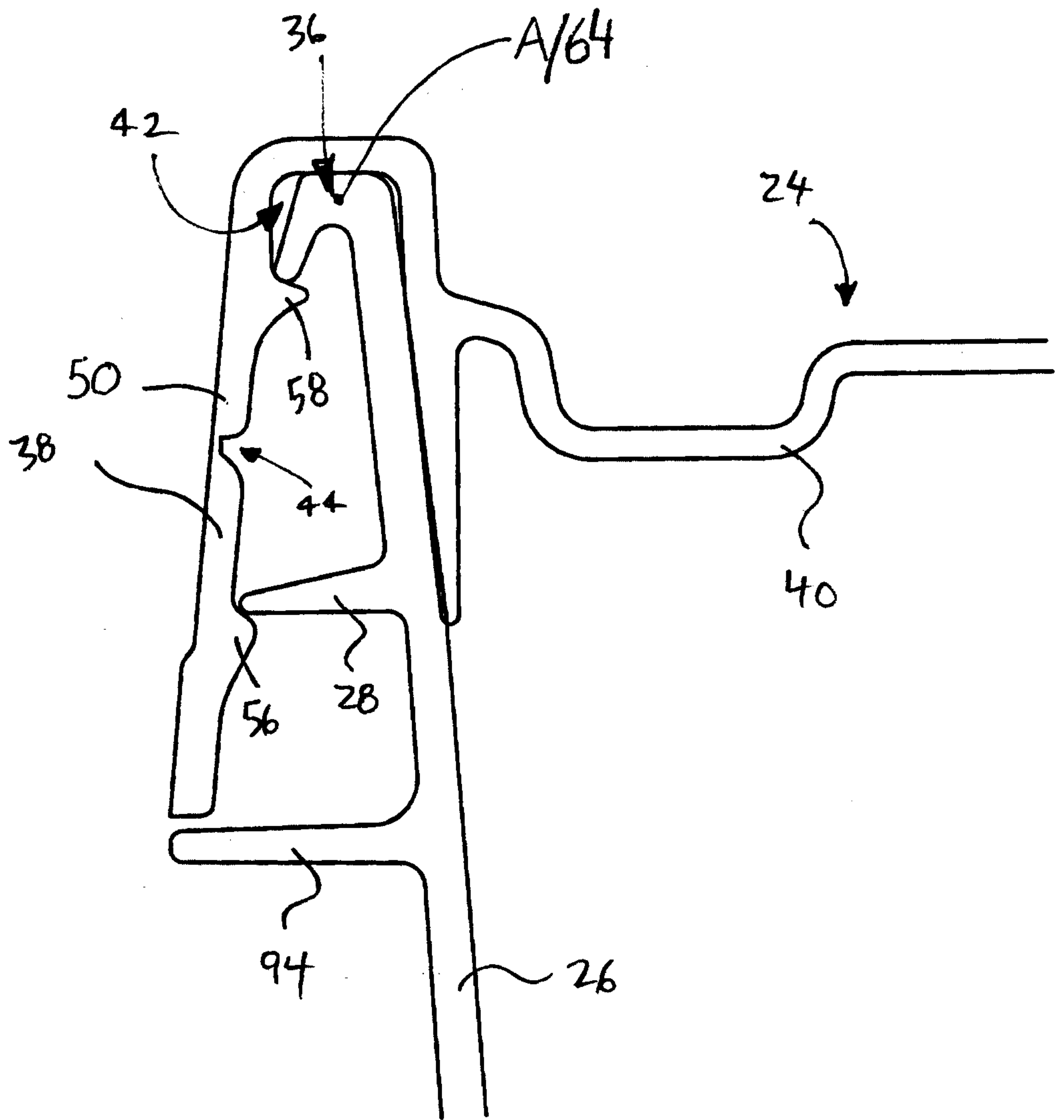

FIGURE 7

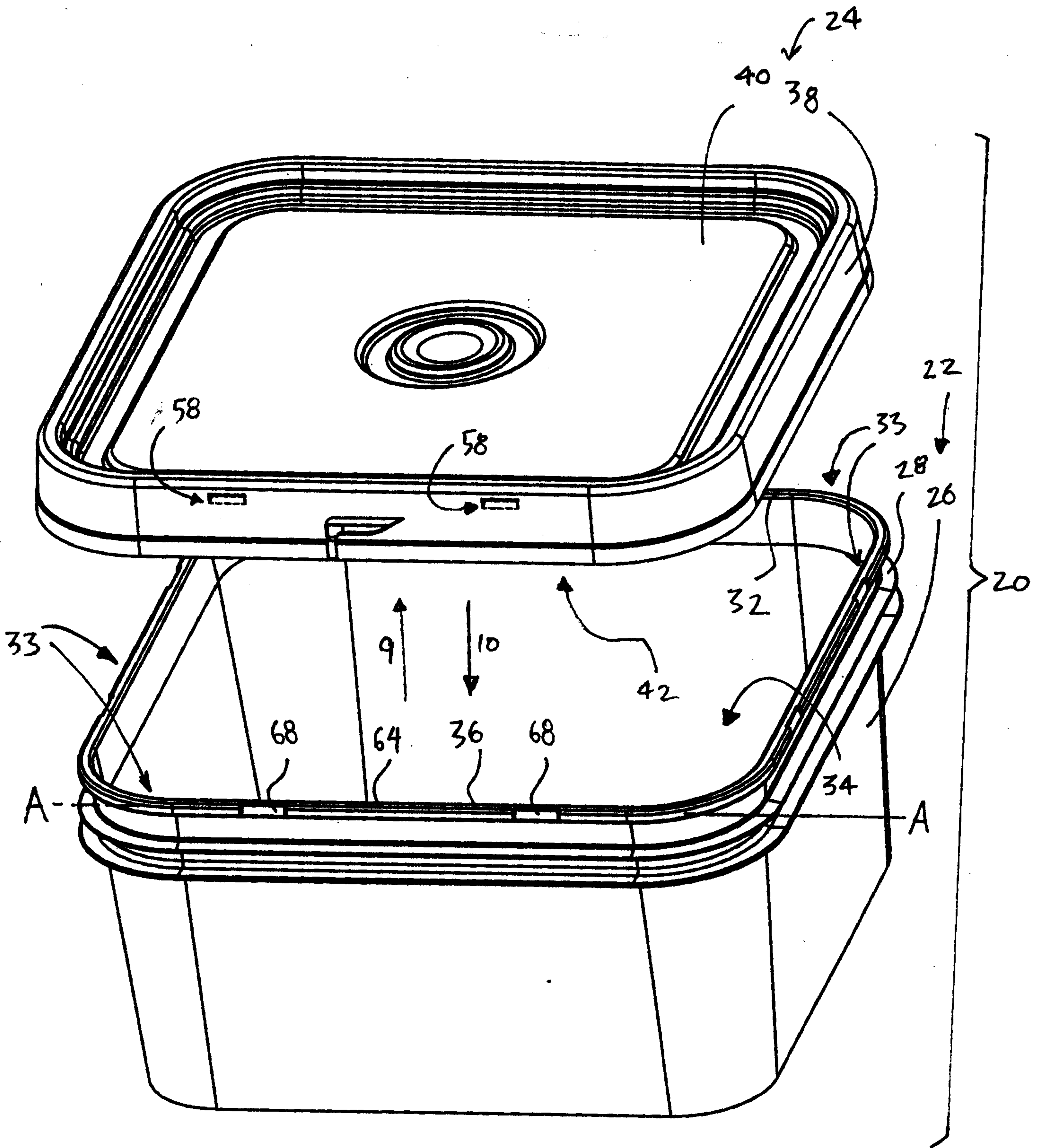

FIGURE 8

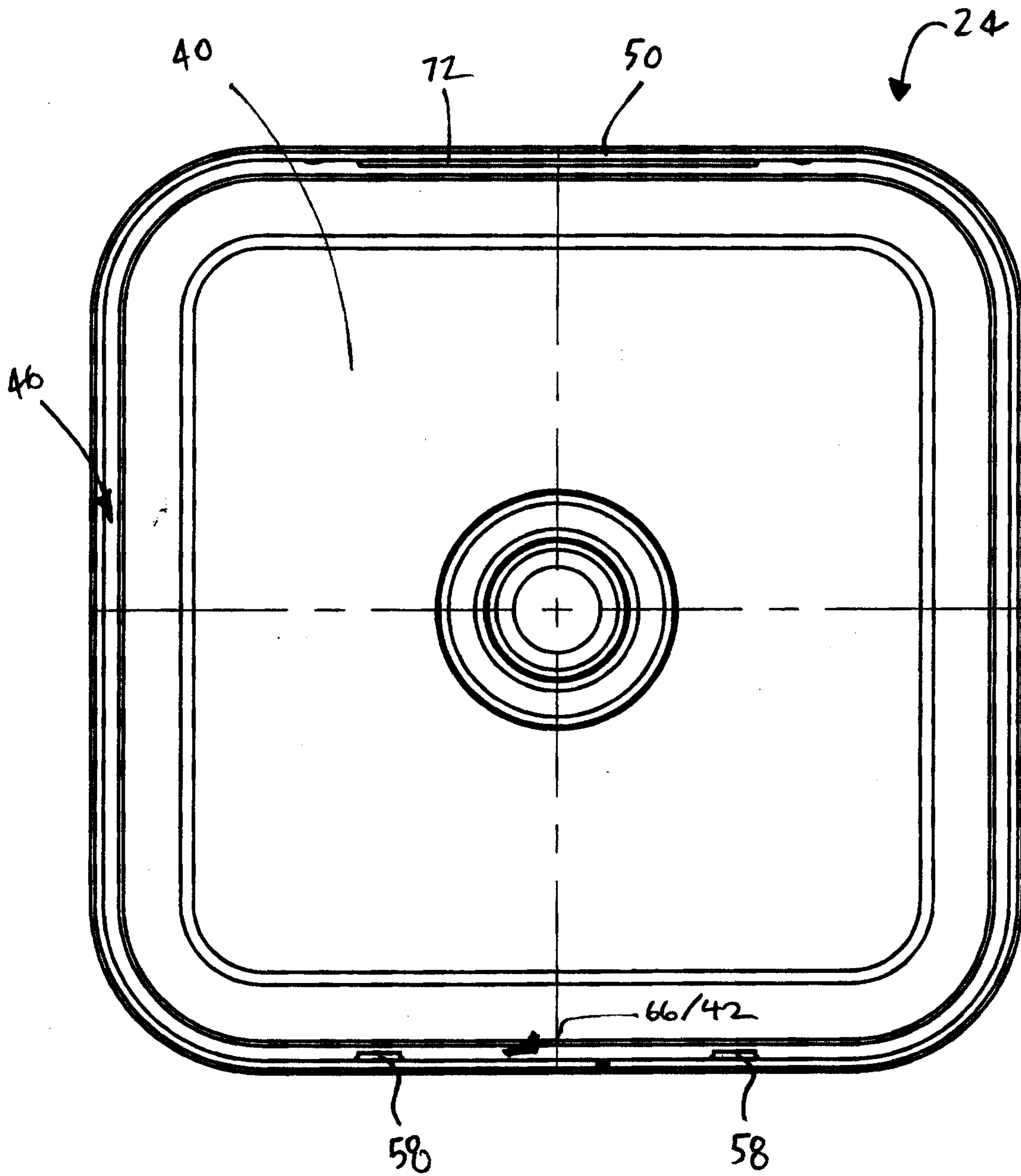

FIGURE 9

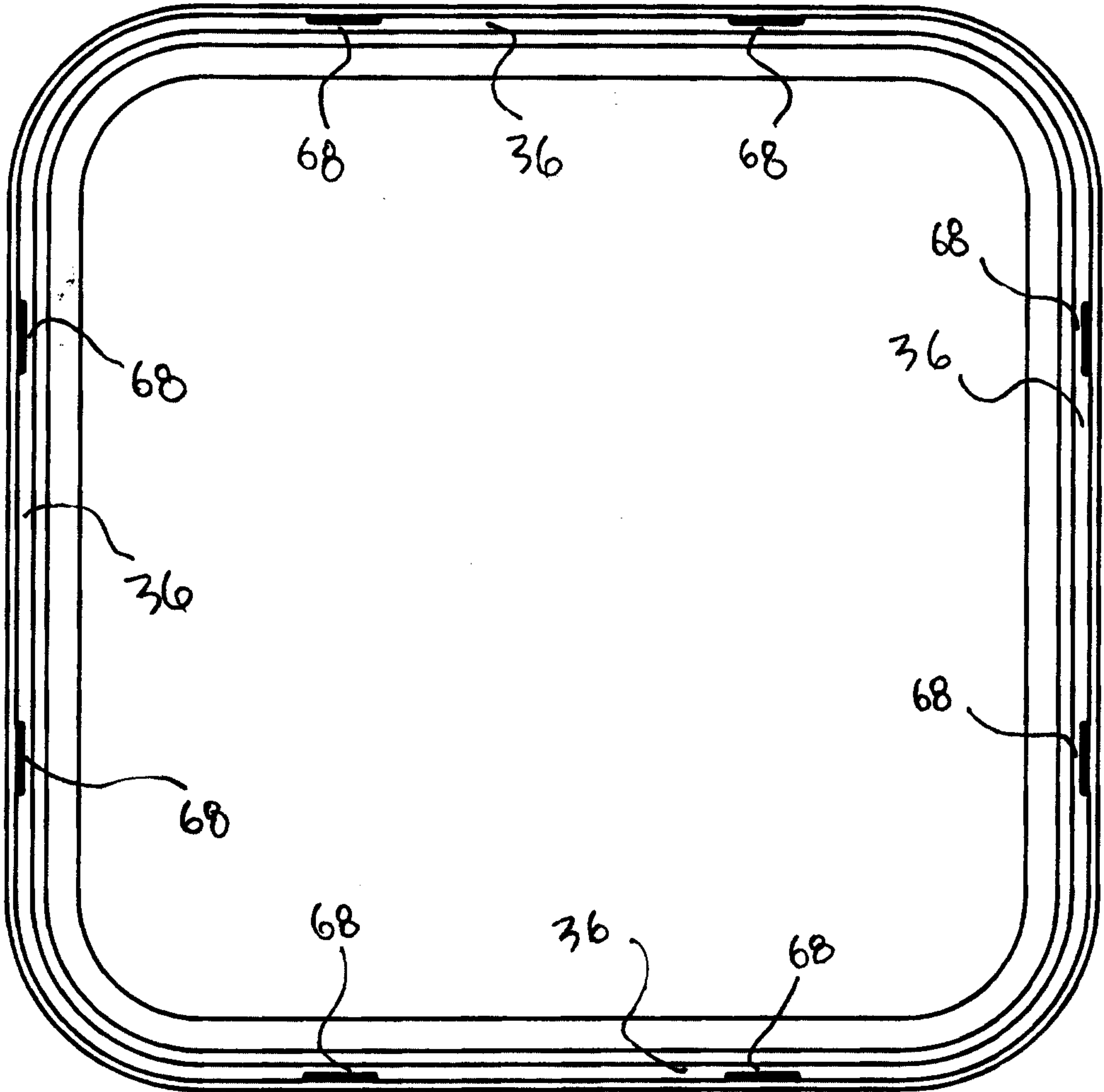

FIGURE 10

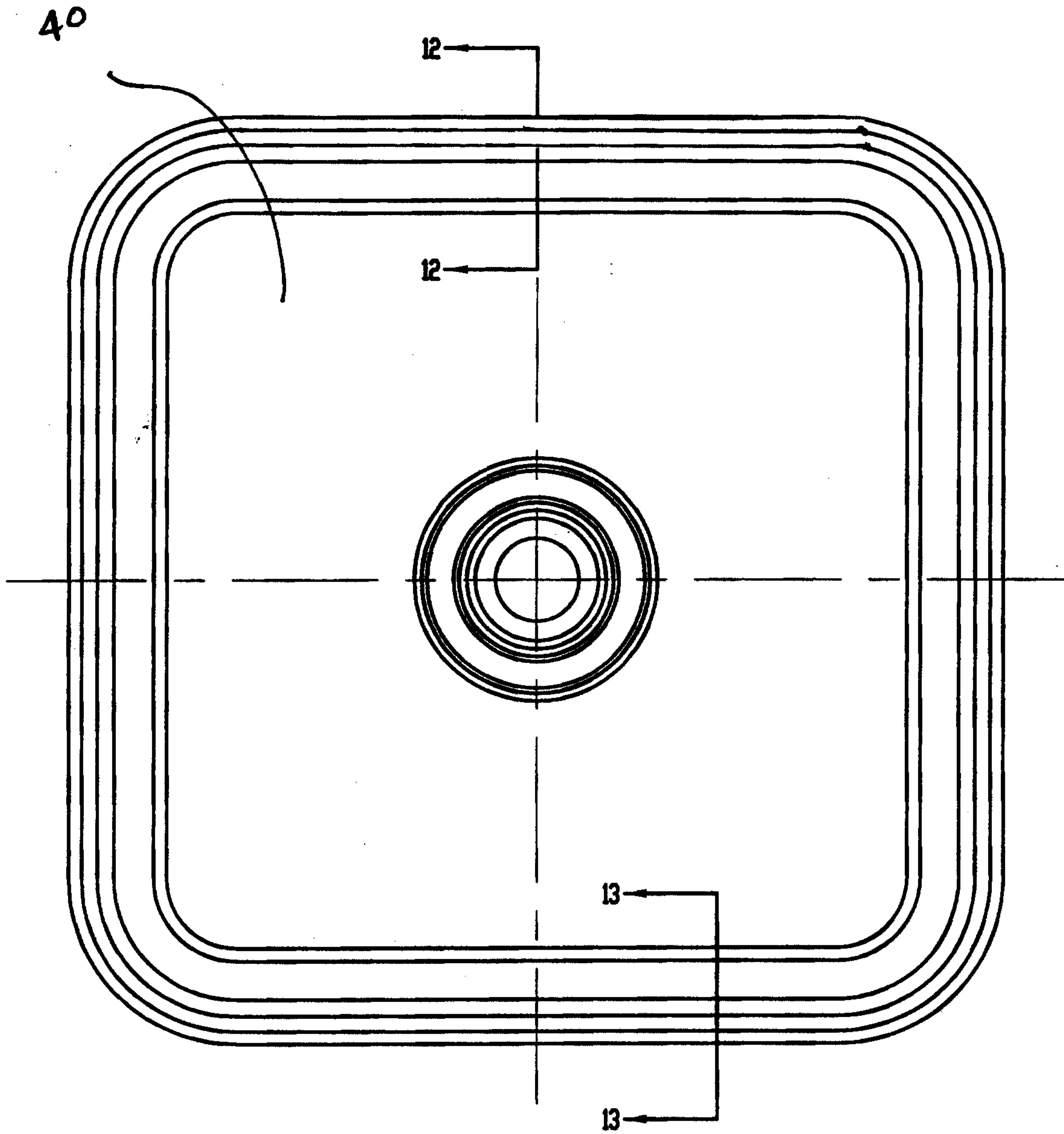

FIGURE 11

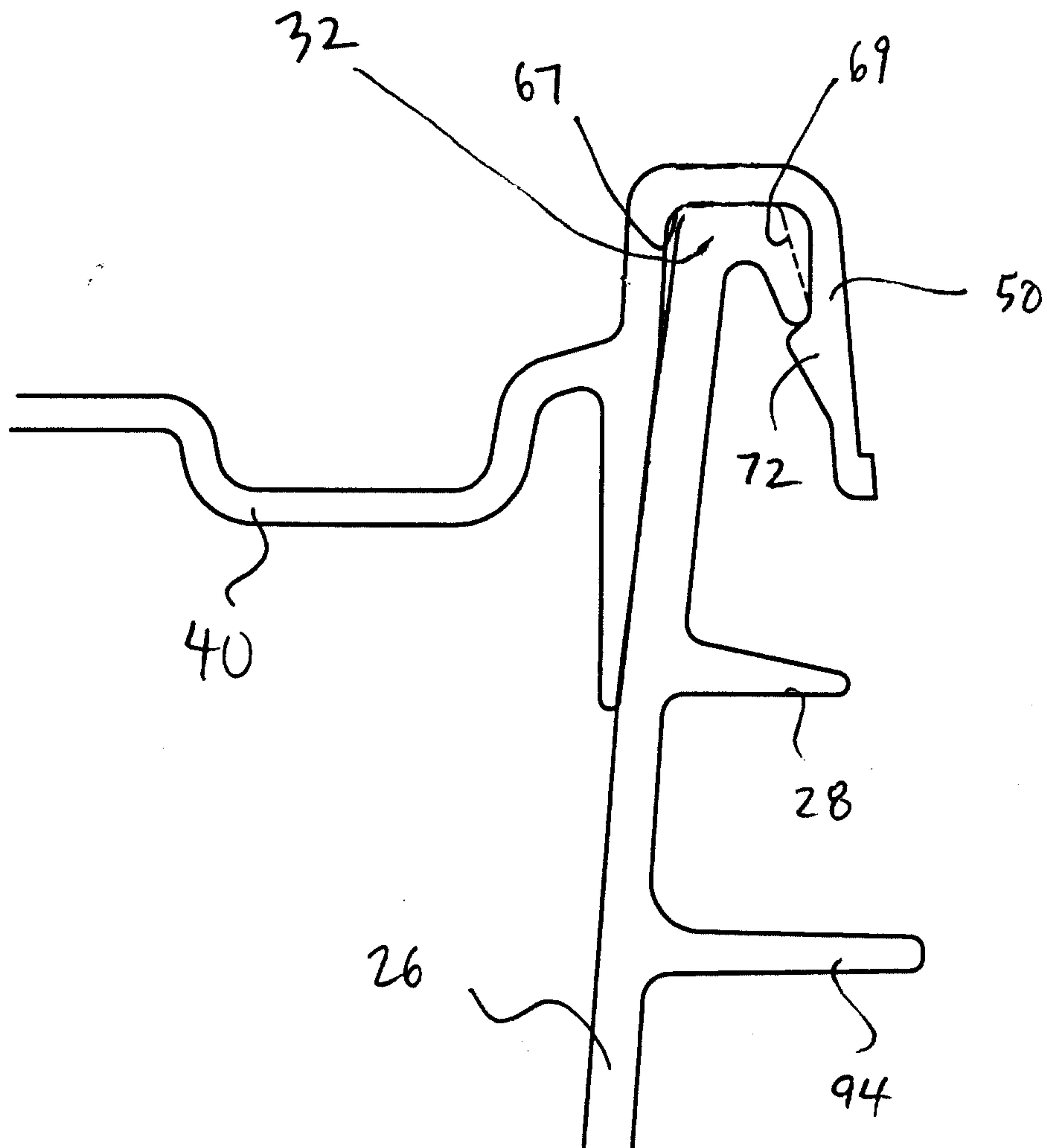

FIGURE 12

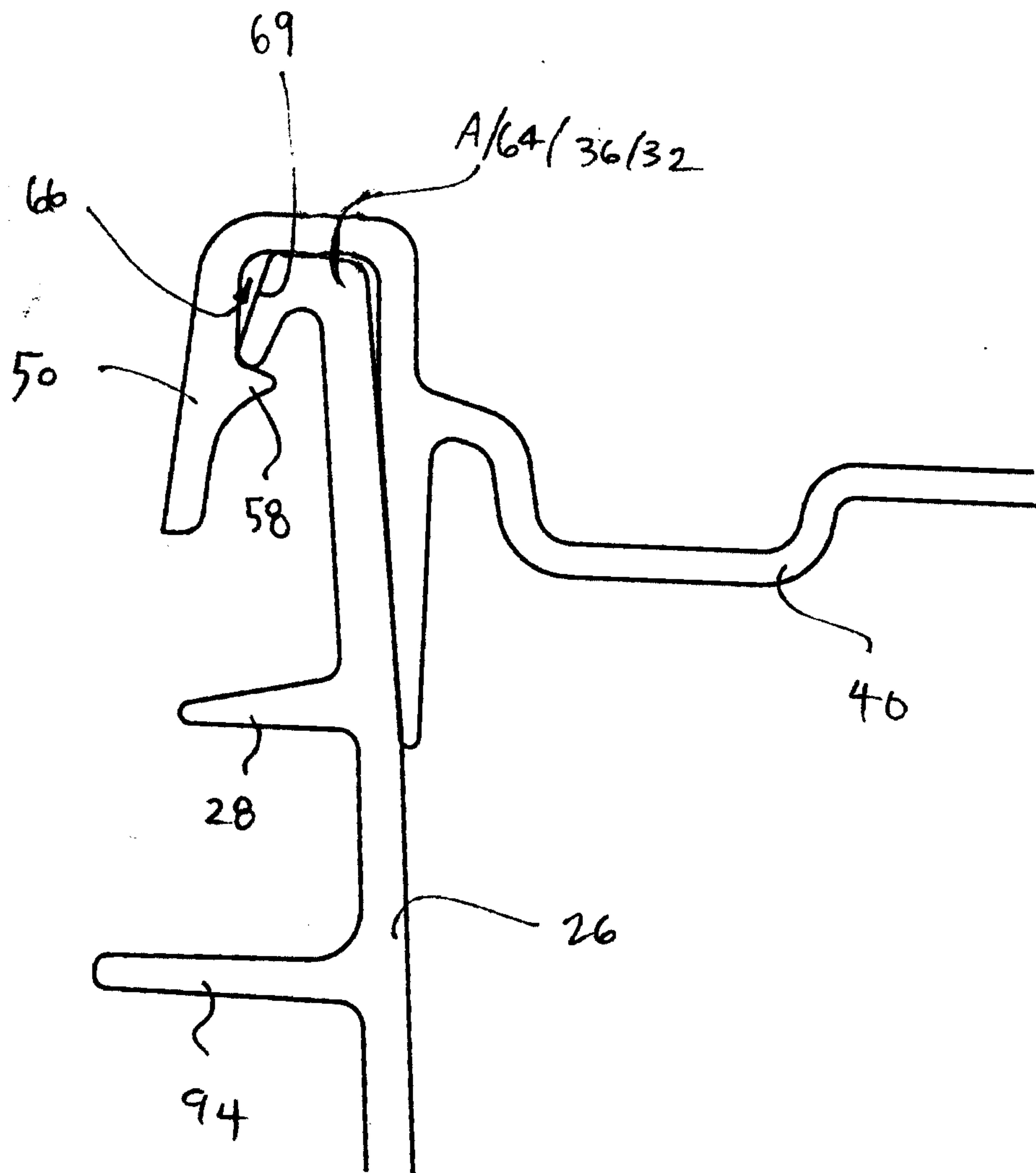

FIGURE 13

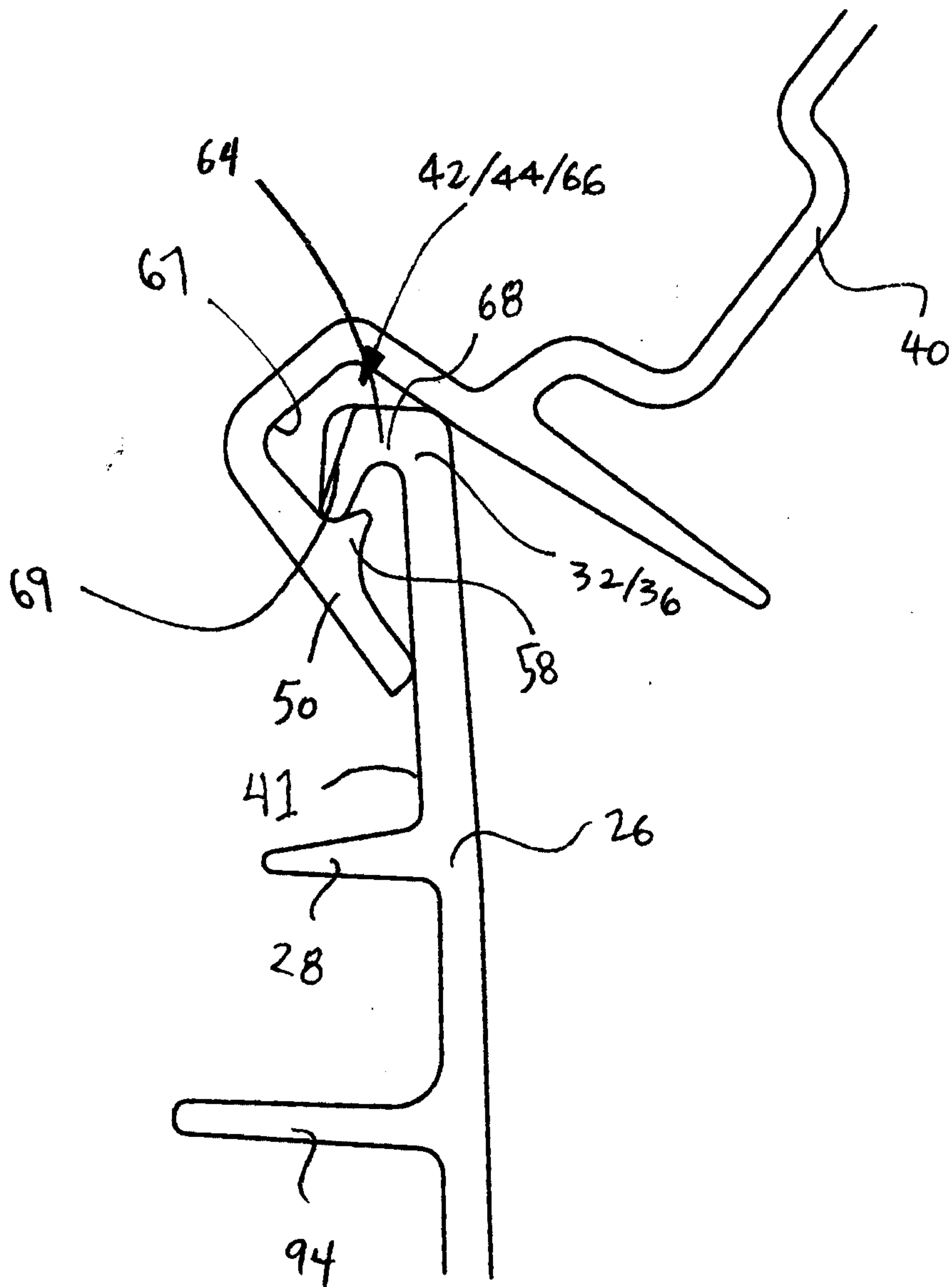

FIGURE 14

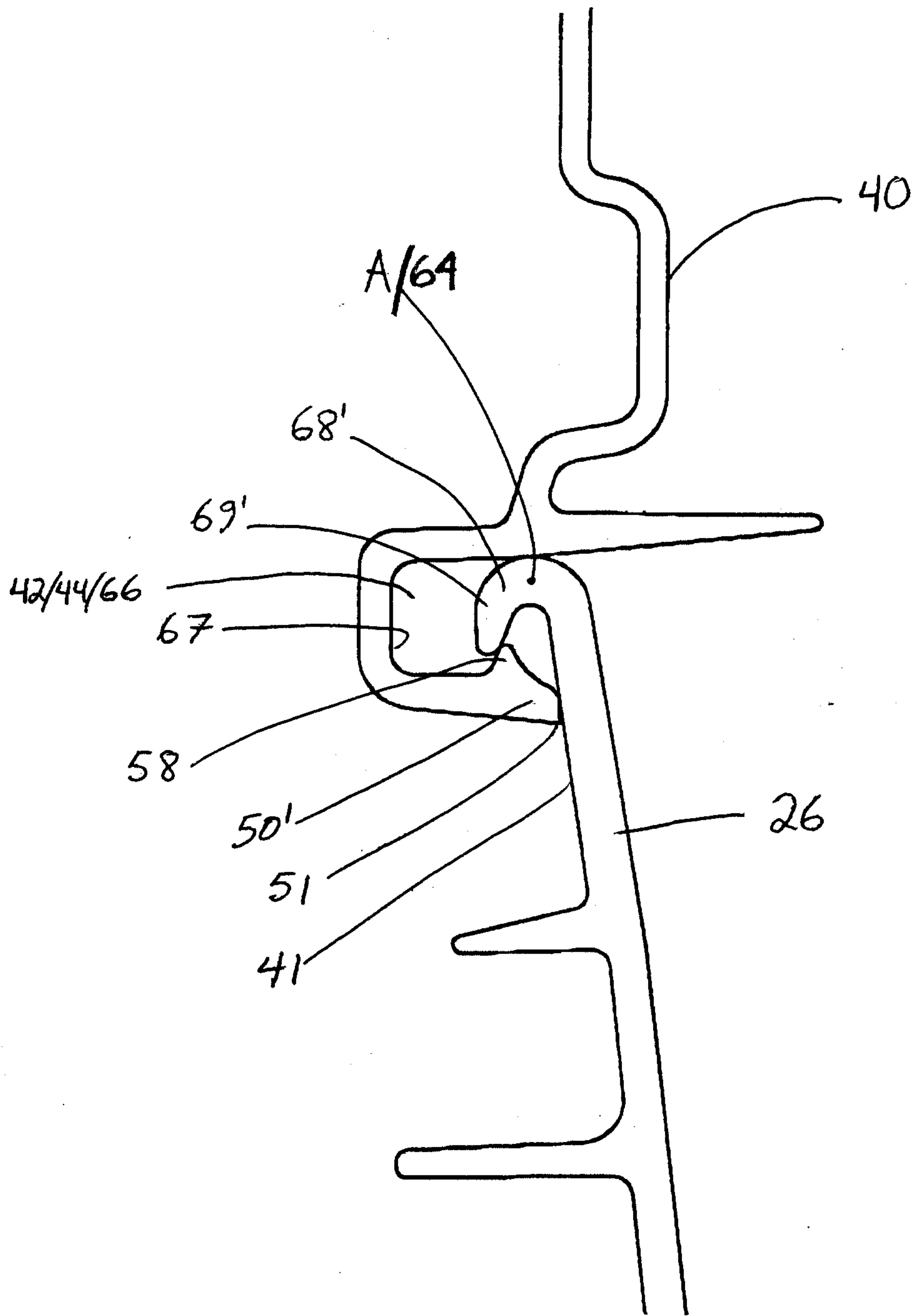

FIG. 15

