

(No Model.)

C. W. H. BLOOD.
PUMP.

No. 558,766.

Patented Apr. 21, 1896.

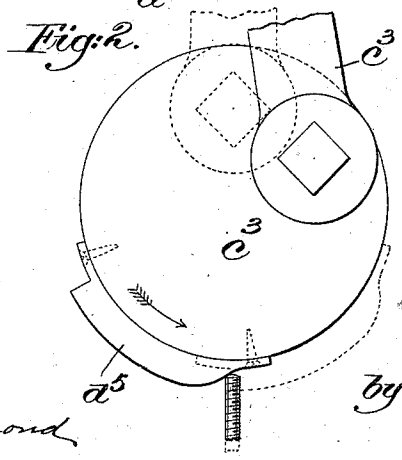
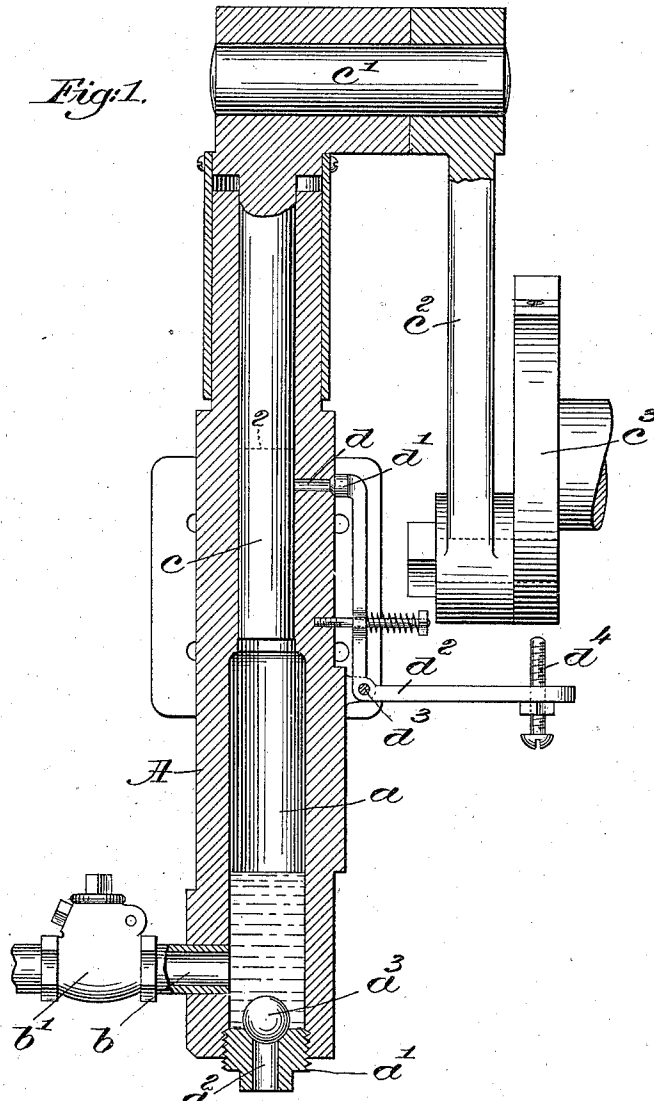

Witnesses.
Edward F. Allen.
Thomas Hammond

Inventor.
Charles W. H. Blood.
by Crosby & Gregory
attys.

UNITED STATES PATENT OFFICE.

CHARLES W. H. BLOOD, OF BOSTON, MASSACHUSETTS, ASSIGNOR TO THE
S. A. WOODS MACHINE COMPANY, OF SAME PLACE.

PUMP.

SPECIFICATION forming part of Letters Patent No. 558,766, dated April 21, 1896.

Application filed June 19, 1895. Serial No. 553,252. (No model.)

To all whom it may concern:

Be it known that I, CHARLES W. H. BLOOD, of Boston, county of Suffolk, State of Massachusetts, have invented an Improvement in
5 Pumps, of which the following description, in connection with the accompanying drawings, is a specification, like letters on the drawings representing like parts.

This invention relates to pumps, the object
10 of the invention being to provide a pump which can be used in drawing or forcing water or liquids containing grit or other foreign matter without danger of injuring the working
15 parts of the pump, and also adapted for any desired use wherein it is desirable at times to shut off the delivery from the pump without stopping the operation of the pump. With
20 this object in view I provide a pump so constructed as to maintain at all times an air-cushion between the pump-plunger and the
25 surface of the liquid operated upon, this air-cushion preventing contact of gritty water with the plunger and cooperating parts of the pump, and also, by reason of its compressibility, enabling the plunger to be operated
even while the delivery is closed.

In the drawings, Figure 1, in vertical section, shows one embodiment of my invention; and Fig. 2, a detail face view of the crank,
30 showing one means of opening and closing the air-valve.

Referring to the drawings, A is a suitable pump-cylinder, the same, as shown, having a
35 central bore shown as counterbored or made larger in diameter near its lower end, as at *a*, said cylinder having its end closed, preferably, by a screw-plug *a'*, containing the inlet-passage *a²*, cooperating with which is a suitable
40 valve, (shown as a ball-valve *a³*.) The pump-outlet is shown at *b*, it being fitted with a usual check-valve *b'*.

The pump-cylinder is fitted with a suitable
45 plunger *c*, jointed at its upper end at *c'* to one end of a connecting-rod *c²*, jointed to and cooperating with a suitable crank *c³*, or the said plunger may be reciprocated in any other
50 suitable or desired manner. The plunger has a reciprocating movement from its full-line position to the position indicated by the dotted line 2, and at a point preferably immediately below the limit of the lower or face end

of its upstroke (indicated by dotted line 2) I have provided a suitable air-inlet *d*, shown as controlled by a valve *d'*, mounted upon one
55 arm of a bell-crank lever *d²*, pivoted at *d³* and provided near its outer end with a set-screw *d⁴*, adapted at times for engagement by a cam surface *d⁵* on the crank *c³*.

When the pump is in operation, each upstroke of the plunger draws water or liquid,
60 as the case may be, into the pump-cylinder through the inlet-passage *a²*, the cylinder filling until the plunger reaches the air-inlet opening *d*, and it may be said cylinder will continue to fill through a greater or less
65 portion of the remaining upstroke of the plunger until the valve *d'* is opened by the cam *d⁵* on the crank engaging the screw *d⁴*, said valve when open at once stopping the inflow
70 of liquid into the chamber, all further movement of the plunger after this valve *d'* is opened serving to fill the space between it and the surface of the liquid previously drawn
75 into the chamber or cylinder with air, to constitute an air-cushion.

The air-valve *d'* may be maintained open for a desired length of time to govern the quantity of air admitted and volume of the air-cushion determined by the length of the cam-surface *d⁵* on the crank. The valve *d'*
80 is, however, usually closed before commencement of the downstroke of the plunger, so that the air previously admitted is confined in the cylinder between the plunger and the
85 surface of the liquid, the plunger, however, acting through its interposed air-cushion to force the liquid outwardly from the cylinder through the delivery *b*, provided the latter is open. An advantage of this air-cushion is
90 that it always keeps the surface of the liquid a greater or less distance below the end of the plunger and at that portion of the cylinder-bore in contact with which said plunger works, so that if the liquid contains gritty or
95 other foreign injurious matter the same is kept from contact with the working surfaces of the pump. Another advantage is that in many instances—such, for instance, as when the pump is used in connection with a knife-grinding machine—it is frequently desired to
100 shut off or reduce the discharge from the pump without stopping the latter. This may

be readily done with my improved pump, for when the delivery is reduced or entirely closed the interposed air-cushion by reason of its compressibility permits continued operation of the plunger without damage to any part of the pump.

I claim—

1. The herein-described suction-pump comprising the pump-cylinder, the plunger working in one end thereof, and the inlet and outlet connected with the other end thereof, combined with an air-inlet located intermediate said ends to maintain an air-cushion within said cylinder below the said plunger, a valve controlling said inlet, connections between said valve and a moving part of the pump-operating mechanism to intermittently move said valve to open the same at a predetermined time and for a predetermined period, and means to automatically close said valve, substantially as described.

2. The combination with a pump-cylinder, a plunger working therein, an inlet and outlet for said pump-cylinder, of an air-inlet for said cylinder, a valve controlling the same, and means to automatically open said valve at each reciprocation of said plunger toward the end of the suction-stroke, and mechanism cooperating therewith to close the same before the beginning of the return stroke thereof, to provide an air-cushion within said cylinder and between the plunger and the liquid op-

erated upon, without diminishing the effective length of the plunger-stroke, substantially as described.

3. The combination with a pump-cylinder, a plunger working therein, an inlet and outlet for said pump-cylinder, of an air-inlet for said cylinder, a valve independent of the plunger and cylinder controlling the said air-inlet, connections between said valve and a moving part of the pump, and means actuating said connections intermittently to automatically open and close said valve at each reciprocation of said plunger to provide an air-cushion within said cylinder and between said cylinder and the liquid operated upon, substantially as described.

4. The combination with a pump-cylinder, a plunger working therein, a suitable crank for operating said plunger, an inlet and outlet for said pump-cylinder, of an air-inlet for said cylinder, a valve controlling said inlet, a cam-surface carried by said crank to automatically open said valve, and means to automatically close said valve, substantially as described.

In testimony whereof I have signed my name to this specification in the presence of two subscribing witnesses.

CHARLES W. II. BLOOD.

Witnesses:

FREDERICK L. EMERY,
EMMA J. BENNETT.