

Aug. 20, 1946.

H. S. HUNT

2,405,955

CARRYING CASE

Filed June 27, 1945

2 Sheets-Sheet 1

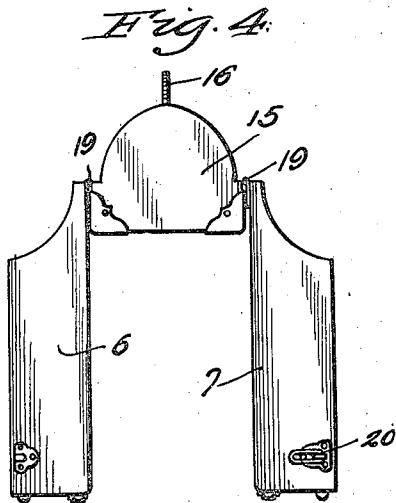
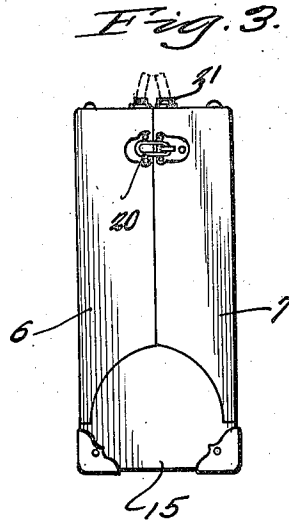
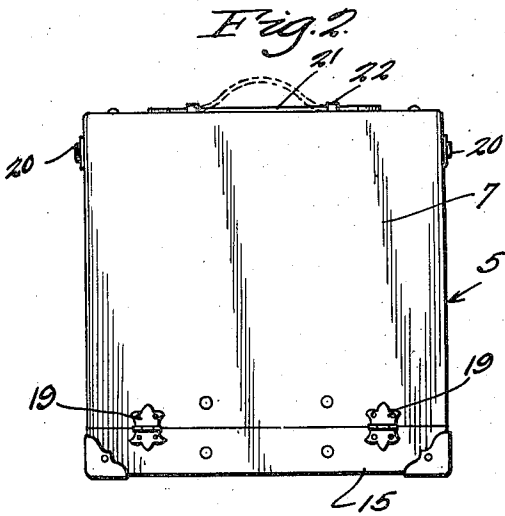
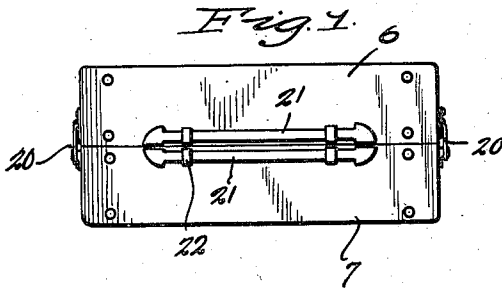

Inventor  
HAROLD S. HUNT

By

Clarence W. O'Brien  
and Harvey B. Jacobson  
Attorneys

Aug. 20, 1946.

H. S. HUNT

2,405,955

CARRYING CASE

Filed June 27, 1945

2 Sheets-Sheet 2

Fig. 5.

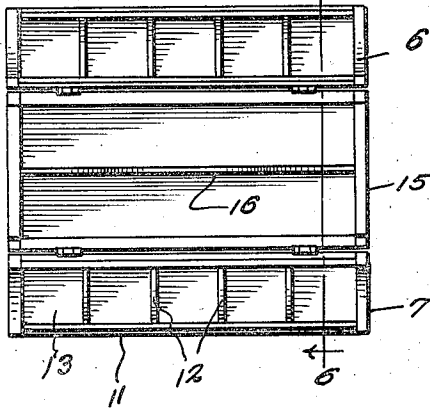

Fig. 6.

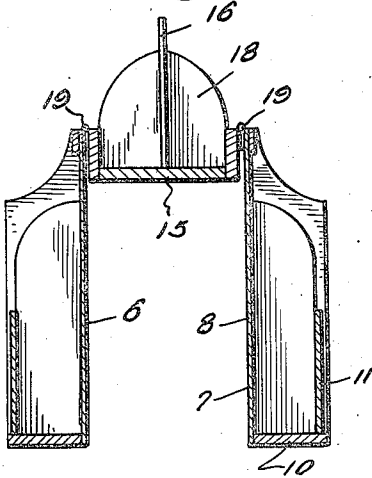

Fig. 7.

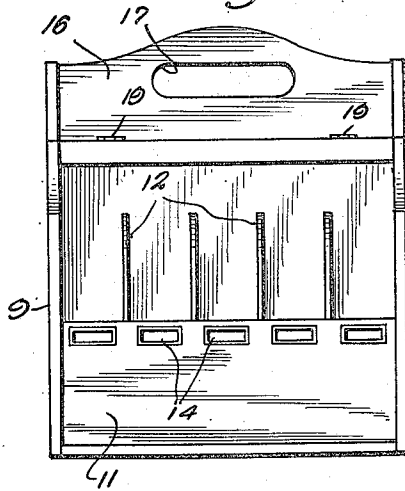

Fig. 8.

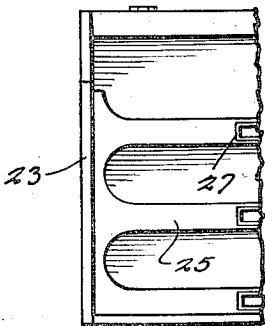
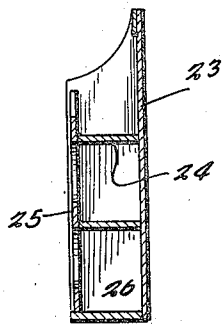

Fig. 9.



Inventor

HAROLD S. HUNT

By

Clarence A. O'Brien  
and Harvey B. Jacobson  
Attorneys

# UNITED STATES PATENT OFFICE

2,405,955

## CARRYING CASE

Harold S. Hunt, Iowa City, Iowa

Application June 27, 1945, Serial No. 601,810

2 Claims. (Cl. 224-45)

1

The present invention relates to new and useful improvements in carrying cases, and more particularly to an article of this character embodying a pair of racks having partitions to form individual compartments therein within which various articles may be carried separated from each other and hingedly connecting the racks to a base member by means of which the racks may be swung into an open position for exposing the contents thereof to easy access and to close the racks against each other to provide a carrying case in which the contents of the racks are enclosed.

The invention is designed particularly for use by basketball and similar athletic squads in which it is important that each player on the team may be provided with individual towels for use on the floor during time out, and for sanitation reasons it is important that the towels for the individual players be kept separated.

It is accordingly an object of the present invention to provide a carrying case in which the towels may be kept in individual compartments and conveniently carried in the case when not in use and in which the case may be opened to place all of the towels simultaneously into an easily accessible position.

A further object of the invention is to provide a device of this character of simple and practical construction, which is neat and attractive in appearance, efficient and reliable in use, relatively inexpensive to manufacture and otherwise well adapted for the purposes for which the same is intended.

Other objects and advantages reside in the details of construction and operation as more fully hereinafter described and claimed, reference being had to the accompanying drawings forming part hereof, wherein like numerals refer to like parts throughout, and in which:

Figure 1 is a top plan view of the case in closed position.

Figure 2 is a side elevational view.

Figure 3 is an end elevational view.

Figure 4 is an end elevational view of the case in open position.

Figure 5 is a top plan view.

Figure 6 is a transverse sectional view taken substantially on a line 6-6 of Figure 5.

Figure 7 is a side elevational view of one of the racks in open position.

Figure 8 is a fragmentary side elevational view of a modified rack construction.

Figure 9 is a vertical sectional view thereof.

Referring now to the drawings in detail, and

2

first with respect to the form of the invention illustrated in Figures 1 to 7, inclusive, the numeral 5 designates the carrying case generally which is composed of a pair of duplicate rack sections 6 and 7 which form the two sides of the carrying case.

Each rack includes a rear wall 8, side walls 9, a bottom wall 10 and a short front wall 11.

The rack is provided with a plurality of vertically extending partitions 12 separating the lower portion of the rack into a plurality of compartments 13, each compartment being identified by a name plate 14 secured to the front wall 11.

The carrying case includes a bottom or base section 15 of tray-like construction and including a longitudinally extending partition 16 having a hand gripping opening 17 formed therein.

The partition 16 and end walls 18 of the bottom or base section 15 extend upwardly above the side edges thereof, as will be apparent from an inspection of Figure 6 of the drawings.

The upper edges of the rear walls 8 of the racks 6 and 7 are hingedly connected to the side edges of the bottom or base section 15 by means of hinges 19 of conventional construction, whereby the racks 6 and 7 may swing vertically downwardly from the closed position, as shown in Figures 1 to 3, inclusive, to their open position, as illustrated in Figures 4 to 7, inclusive.

When in closed position, the racks 6 and 7 are secured to each other by a conventional form of catches 20 and to the bottoms 10 of the racks are secured leather or other flexible straps 21 slidable in guides 22 to provide handles positioned on top of the case when the racks are in their closed position for conveniently carrying the case.

When the racks 6 and 7 are swung downwardly into their open position at opposite sides of the case, the racks support the bottom or base section 15 in an elevated position between the racks and may be carried in their open position by means of the handle 17.

The bottom or base section then forms a tray within which various articles may be carried, and each of the compartments 13 of the racks may contain a towel or other personal toilet articles in a conveniently accessible position.

In the form of the invention illustrated in Figures 8 and 9 of the drawings, one of the racks is designated at 23 and is formed with horizontal partitions 24 each having a relatively low front wall 25 to provide individual compartments 26 in the racks. The front wall for each of the compartments 26 may be provided with a name

plate 27.

3

In view of the foregoing description taken in conjunction with the accompanying drawings, it is believed that a clear understanding of the construction, operation and advantages of the device will be quite apparent to those skilled in the art. A more detailed description is accordingly deemed unnecessary.

It is to be understood, however, that even though I have herein shown and described a preferred embodiment of my invention, the same is susceptible to certain changes fully comprehended by the spirit of the invention as herein described and the scope of the appended claims.

Having thus described the invention, what I claim is:

1. A carrying case including a bottom and a pair of side sections, said side sections being constructed to form racks, and means hingedly connecting the racks to the bottom for downwardly swinging opening movement into an upright po-

4

sition below the bottom and adapted to support the bottom in an elevated position between the open racks, said bottom comprising a tray having a longitudinal central upstanding partition therein apertured to provide a hand grip for use in carrying the bottom with the side sections depending therefrom when opened.

2. A carrying case including a bottom and a pair of side sections, said side sections being constructed to form racks and said bottom being constructed to form a tray, and means hingedly connecting the racks to the sides of the tray for vertical swinging movement into and out of open position, said racks closing the tray when in raised position, and said racks extending downwardly at the sides of the tray when in open position to support the tray in an elevated position between the racks.

HAROLD S. HUNT.