



(12) **DEMANDE DE BREVET CANADIEN
CANADIAN PATENT APPLICATION**

(13) **A1**

(86) Date de dépôt PCT/PCT Filing Date: 2020/05/15
 (87) Date publication PCT/PCT Publication Date: 2020/11/26
 (85) Entrée phase nationale/National Entry: 2021/11/12
 (86) N° demande PCT/PCT Application No.: US 2020/033285
 (87) N° publication PCT/PCT Publication No.: 2020/236659
 (30) Priorité/Priority: 2019/05/17 (US62/849,494)

(51) Cl.Int./Int.Cl. *H02J 13/00* (2006.01),
H02H 3/08 (2006.01), *H03K 17/0812* (2006.01),
H03K 17/16 (2006.01), *H03K 17/687* (2006.01),
H05B 47/25 (2020.01)
 (71) Demandeur/Applicant:
LUTRON TECHNOLOGY COMPANY LLC, US
 (72) Inventeurs/Inventors:
BOLLINGER, BRIAN J., US;
CHITTA, VENKATESH, US;
WALDRON, JONATHAN, US;
CHOLASHARI, FIROZBABU, US
 (74) Agent: GOWLING WLG (CANADA) LLP

(54) Titre : DISPOSITIF DE COMMANDE DE CHARGE AYANT UN CIRCUIT D'ATTAQUE DE GRILLE EN BOUCLE FERMÉE

(54) Title: LOAD CONTROL DEVICE HAVING A CLOSED-LOOP GATE DRIVE CIRCUIT

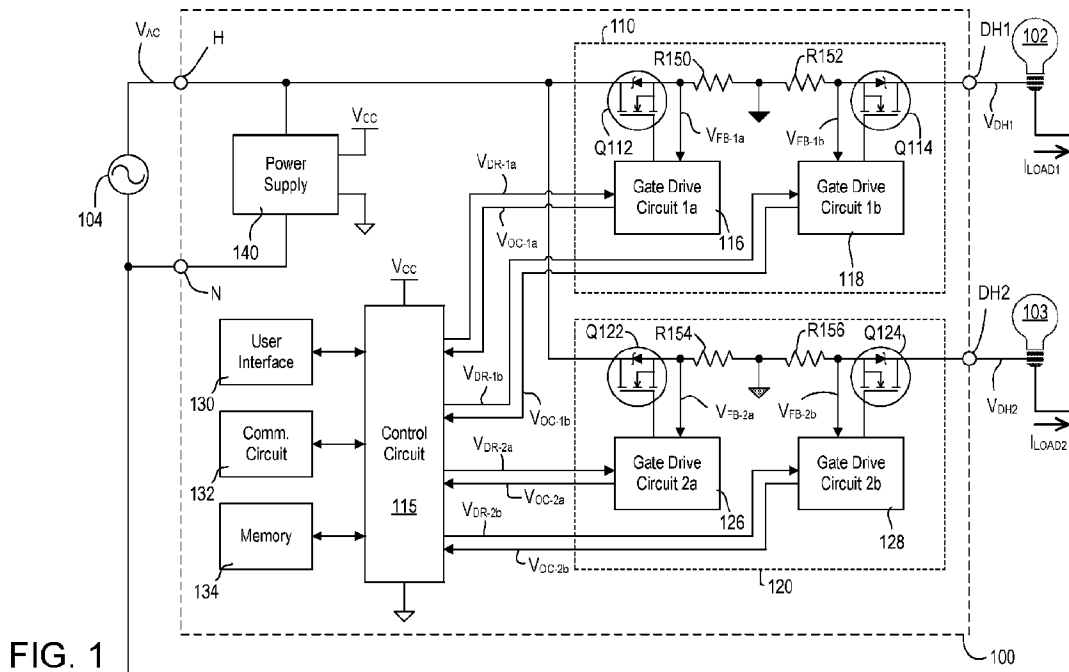

(57) **Abrégé/Abstract:**

A load control device for controlling power delivered from an AC power source to an electrical load may have a closed-loop gate drive circuit for controlling a semiconductor switch of a controllably conductive device. The controllably conductive device may be coupled in series between the source and the load. The gate drive circuit may generate a target signal in response to a control circuit. The gate drive circuit may shape the target signal over a period of time and may increase the target signal to a predetermined level after the period of time. The gate drive circuit may receive a feedback signal that indicates a magnitude of a load current conducted through the semiconductor switch. The gate drive circuit may generate a gate control signal in response to the target signal and the feedback signal, and render the semiconductor switch conductive and non-conductive in response to the gate control signal.

(12) INTERNATIONAL APPLICATION PUBLISHED UNDER THE PATENT COOPERATION TREATY (PCT)

(19) World Intellectual Property
 Organization
 International Bureau



(10) International Publication Number
WO 2020/236659 A1

(43) International Publication Date
 26 November 2020 (26.11.2020)

(51) International Patent Classification:

H05B 39/04 (2006.01) *H05B 47/25* (2020.01)
H05B 41/392 (2006.01) *H03K 17/16* (2006.01)
H05B 47/14 (2020.01)

(71) Applicant: **LUTRON TECHNOLOGY COMPANY LLC** [US/US]; 7200 Suter Road, Coopersburg, Pennsylvania 18036-1299 (US).

(21) International Application Number:

PCT/US2020/033285

(72) Inventors: **BOLLINGER, Brian J.**; 7200 Suter Road, Coopersburg, Pennsylvania 18036-1299 (US). **CHITTA, Venkatesh**; 7200 Suter Road, Coopersburg, Pennsylvania 18036-1299 (US). **WALDRON, Jonathan**; 7200 Suter Road, Coopersburg, Pennsylvania 18036-1299 (US). **CHOLASHARI, Firozbabu**; 7200 Suter Road, Coopersburg, Pennsylvania 18036-1299 (US).

(22) International Filing Date:

15 May 2020 (15.05.2020)

(25) Filing Language:

English

(26) Publication Language:

English

(74) Agent: **PISCITELLI, Michael F.**; 1835 Market street, Suite 1050, Philadelphia, Pennsylvania 19103 (US).

(30) Priority Data:

62/849,494 17 May 2019 (17.05.2019) US

(81) Designated States (unless otherwise indicated, for every kind of national protection available): AE, AG, AL, AM, AO, AT, AU, AZ, BA, BB, BG, BH, BN, BR, BW, BY, BZ, CA, CH, CL, CN, CO, CR, CU, CZ, DE, DJ, DK, DM, DO,

(54) Title: LOAD CONTROL DEVICE HAVING A CLOSED-LOOP GATE DRIVE CIRCUIT

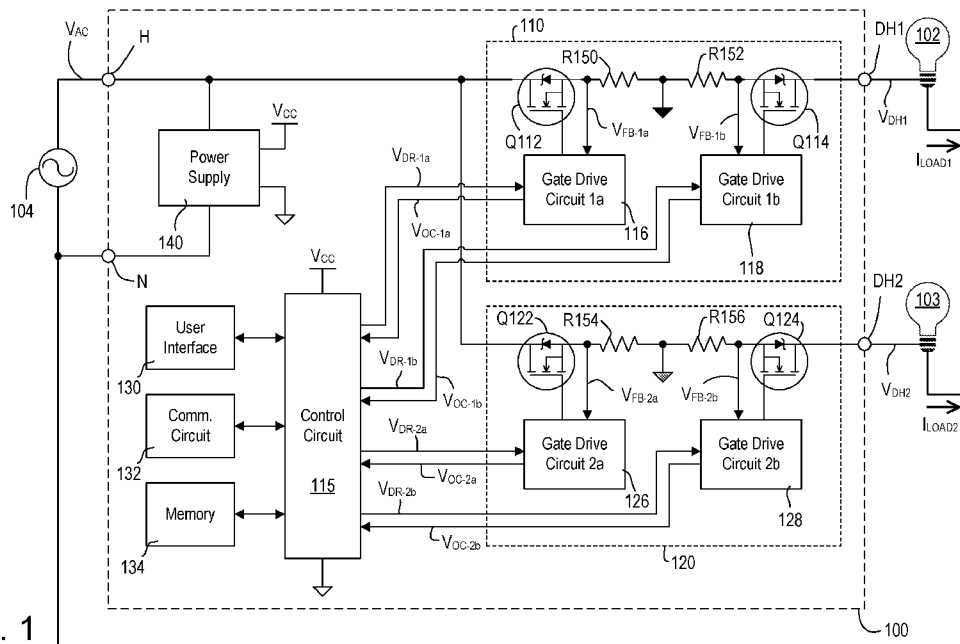

FIG. 1

(57) Abstract: A load control device for controlling power delivered from an AC power source to an electrical load may have a closed-loop gate drive circuit for controlling a semiconductor switch of a controllably conductive device. The controllably conductive device may be coupled in series between the source and the load. The gate drive circuit may generate a target signal in response to a control circuit. The gate drive circuit may shape the target signal over a period of time and may increase the target signal to a predetermined level after the period of time. The gate drive circuit may receive a feedback signal that indicates a magnitude of a load current conducted through the semiconductor switch. The gate drive circuit may generate a gate control signal in response to the target signal and the feedback signal, and render the semiconductor switch conductive and non-conductive in response to the gate control signal.



WO 2020/236659 A1

WO 2020/236659 A1 

DZ, EC, EE, EG, ES, FI, GB, GD, GE, GH, GM, GT, HN, HR, HU, ID, IL, IN, IR, IS, JO, JP, KE, KG, KH, KN, KP, KR, KW, KZ, LA, LC, LK, LR, LS, LU, LY, MA, MD, ME, MG, MK, MN, MW, MX, MY, MZ, NA, NG, NI, NO, NZ, OM, PA, PE, PG, PH, PL, PT, QA, RO, RS, RU, RW, SA, SC, SD, SE, SG, SK, SL, ST, SV, SY, TH, TJ, TM, TN, TR, TT, TZ, UA, UG, US, UZ, VC, VN, WS, ZA, ZM, ZW.

- (84) Designated States** (*unless otherwise indicated, for every kind of regional protection available*): ARIPO (BW, GH, GM, KE, LR, LS, MW, MZ, NA, RW, SD, SL, ST, SZ, TZ, UG, ZM, ZW), Eurasian (AM, AZ, BY, KG, KZ, RU, TJ, TM), European (AL, AT, BE, BG, CH, CY, CZ, DE, DK, EE, ES, FI, FR, GB, GR, HR, HU, IE, IS, IT, LT, LU, LV, MC, MK, MT, NL, NO, PL, PT, RO, RS, SE, SI, SK, SM, TR), OAPI (BF, BJ, CF, CG, CI, CM, GA, GN, GQ, GW, KM, ML, MR, NE, SN, TD, TG).

Published:

- *with international search report (Art. 21(3))*
- *before the expiration of the time limit for amending the claims and to be republished in the event of receipt of amendments (Rule 48.2(h))*

LOAD CONTROL DEVICE HAVING A CLOSED-LOOP GATE DRIVE CIRCUIT

CROSS-REFERENCE TO RELATED APPLICATIONS

[0001] This application claims the benefit of Provisional U.S. Patent Application No. 62/849,494, filed May 17, 2019, the disclosure of which is incorporated herein by reference in its entirety.

BACKGROUND

[0002] Prior art load control devices, such as dimmer switches, may be coupled in series electrical connection between an alternating-current (AC) power source and a lighting load for controlling the amount of power delivered from the AC power source to the lighting load. A standard dimmer switch may typically comprise a bidirectional semiconductor switch, *e.g.*, a thyristor (*e.g.*, such as a triac) or two field-effect transistors (FETs) in anti-series connection. The bidirectional semiconductor switch may be coupled in series between the AC power source and the load and is controlled to be conductive and non-conductive for portions of a half cycle of the AC power source to thus control the amount of power delivered to the electrical load. Generally, dimmer switches may use either a forward phase-control dimming technique or a reverse phase-control dimming technique in order to control when the bidirectional semiconductor switch is rendered conductive and non-conductive to thus control the power delivered to the load.

[0003] There is a need for load control devices that meet the electromagnetic compatibility (EMC) performance requirements during turn-on and turn-off events across a variety of electrical loads. The inconsistency of EMC performance across a variety of electrical loads can cause some load control devices to create audible buzzing noises or damage their internal components during turn-on or turn-off events. Such EMC inconsistencies limit the compatible range of electrical loads for a load control device.

[0004] There is also a need for load control devices that are compatible with a broader range of internal components. For example, when an internal component, such as a semiconductor switch of an existing load control device has been changed or second sourced, the load control device may become inoperable or require a redesign due to the change in operating characteristics of the internal component. This is not only burdensome, but also costly.

[0005] Further, there is a need for overcurrent protection design in a load control device that allows for greater tolerance of natural overcurrent conditions but also prevents high current runaway. Existing overcurrent protection schemes in load control devices are rigid and do not allow for broad load compatibility. For example, some existing overcurrent protection schemes may trigger when a current limit is exceeded, regardless of any determined characteristics of the semiconductor switch or load.

SUMMARY

[0006] A load control device for controlling power delivered from an AC power source to an electrical load may have a closed-loop gate drive circuit for controlling a semiconductor switch (*e.g.*, a field-effect transistor) of a controllably conductive device. The controllably conductive device may be adapted to be coupled in series between the AC power source and the electrical load, such that the semiconductor switch may conduct a load current through the electrical load.

[0007] A load control device may further comprise a control circuit that may generate a drive signal for controlling the gate drive circuit. The gate drive circuit may generate a target signal in response to the control circuit. For example, the gate drive circuit may generate a target signal in response to the drive signal generated by the control circuit. The gate drive circuit may shape (*e.g.*, wave-shape) the target signal over a period of time, for example, by adjusting a magnitude of the target signal with respect to time over the period of time. The gate drive circuit may receive a first feedback signal that may indicate a magnitude of the load current conducted through the semiconductor switch.

[0008] The gate drive circuit may generate a gate control signal in response to the target signal and the feedback signal. For example, the gate drive circuit may render the semiconductor

switch of the controllably conductive device conductive and non-conductive in response to the gate control signal. The gate drive circuit may adjust a magnitude of the gate control signal in response to a magnitude of the feedback signal to adjust the magnitude of the load current towards a target current indicated by a magnitude of the target signal. For example, the gate drive circuit may monitor the load current through the electrical load and may adjust the magnitude of the gate control signal in response to the magnitude of the feedback signal and adjust the magnitude of the load current towards to the target current indicated by the magnitude of the target signal.

[0009] The gate drive circuit may further receive a second feedback signal that may indicate a magnitude of a voltage developed across the semiconductor switch. When rendering the semiconductor switch non-conductive, the gate drive circuit may shape (*e.g.*, wave-shape) over a turn-off period. For example, the gate drive circuit may begin to shape the gate control signal (*e.g.*, at the beginning of the turn-off period) in response to the second feedback signal (*e.g.*, when the magnitude of the second feedback signal exceeds a threshold).

[0010] When rendering the semiconductor switch conductive, the gate drive circuit may shape the target signal over a turn-on period. In examples, the gate drive circuit may increase the target signal to a predetermined level after the turn-on period. When the magnitude of the target signal is at the predetermined level, the gate drive circuit may limit the magnitude of the load current to a maximum level (*e.g.*, a maximum current level) set by the predetermined level. As described herein, the gate drive circuit may limit the magnitude of the load current to the maximum current level while the semiconductor switch is conductive. The gate drive circuit may detect an overcurrent condition when the magnitude of the gate drive signal is at the predetermined level (*e.g.*, which indicates that the magnitude of the load current is at the maximum current level). The gate drive circuit may render the semiconductor switch non-conductive after a trip time period from when the overcurrent condition is detected. The trip time period may be based on a parameter of the semiconductor switch. The parameter of the semiconductor switch may include a temperature across the semiconductor switch, a power of the semiconductor switch, a voltage developed across the semiconductor switch, and/or the like. Alternatively, in some examples, the trip time period may be a fixed value.

BRIEF DESCRIPTION OF THE DRAWINGS

[0011] FIG. 1 is a block diagram of an example load control device for controlling the amount of power delivered to an electrical load.

[0012] FIG. 2 is a block diagram of the load control device of FIG. 1 in an alternate configuration for controlling the amount of power delivered to an electrical load via a parallel output configuration.

[0013] FIG. 3 is a block diagram of an example gate drive circuit configured to control the amount of power delivered to an electrical load.

[0014] FIG. 4 shows examples of waveforms that illustrate an operation of a load control device using a forward phase-control dimming technique.

[0015] FIG. 5 shows examples of waveforms that illustrate an operation of a load control device using a reverse phase-control dimming technique.

[0016] FIG. 6 shows examples of waveforms that illustrate an operation of a gate drive circuit to render a semiconductor switch conductive using a forward phase-control dimming technique.

[0017] FIG. 7 shows examples of waveforms that illustrate an operation of a gate drive circuit to render a semiconductor switch conductive using a forward phase-control dimming technique when the semiconductor switch is experiencing an overcurrent condition.

[0018] FIG. 8 shows examples of waveforms that illustrate an operation of a gate drive circuit to render a semiconductor switch conductive using a forward phase-control dimming technique when the semiconductor switch is experiencing an inrush current condition.

[0019] FIG. 9 shows examples of waveforms that illustrate an operation of a gate drive circuit to render a semiconductor switch non-conductive using a reverse phase-control dimming technique.

DETAILED DESCRIPTION

[0020] FIG. 1 is a block diagram of an example load control device 100 (*e.g.*, a dimmer switch) for controlling the amount of power delivered from an alternating-current (AC) power source to one or more electrical loads, such as lighting loads 102, 103. The load control device 100 may include a hot terminal H coupled to a hot side of the AC power source 104 for receiving an AC mains line voltage V_{AC} , a first dimmed-hot terminal DH1 coupled to the lighting load 102, and a second dimmed-hot terminal DH2 coupled to the lighting load 103. The load control device 100 may also include a neutral terminal N that may be adapted to be coupled to a neutral side of the AC power source 104.

[0021] The load control device 100 may comprise a first load control circuit 110 (*e.g.*, a first dimming circuit) and a second load control circuit 120 (*e.g.*, a second dimming circuit). The first load control circuit 110 may comprise a first controllably conductive device having semiconductor switches, such as two field-effect transistors (FETs) Q112, Q114. The FETs Q112, Q114 may be coupled in anti-series connection between the hot terminal H and the dimmed-hot terminal DH1. The junction of the FETs Q112, Q114 may be coupled to circuit common. The first load control circuit 110 may also include a first drive circuit 116 (*e.g.*, a first closed-loop gate drive circuit) for controlling the first FET Q112 and a second drive circuit 118 (*e.g.*, a second closed-loop gate drive circuit) for controlling the second FET Q114. In some alternate examples, the first controllably conductive device of the first load control circuit 110 may comprise a single FET in a full-wave bridge rectifier and the first load control circuit may comprise a single closed-loop gate drive circuit.

[0022] The load control device 100 may comprise a control circuit 115, *e.g.*, a digital control circuit, for controlling the first load control circuit 110 to conduct a first load current I_{LOAD1} through the first lighting load 102, and for controlling the second load control circuit 120 to conduct a second load current I_{LOAD2} through the second lighting load 103. The control circuit 115 may include one or more of a processor (*e.g.*, a microprocessor), a microcontroller, a programmable logic device (PLD), a field programmable gate array (FPGA), an application specific integrated circuit (ASIC), or any suitable controller or processing device. The load control device 100 may include a memory 134 configured to store operational characteristics of the load control device 100. The memory 134 may be implemented as an external integrated circuit (IC) or as an internal circuit of the control circuit

115. The load control device 100 may include a communication circuit 132 configured to transmit and receive messages (*e.g.*, digital messages). The communication circuit 132 may be implemented as an external circuit or as an internal circuit of the control circuit 115.

[0023] The load control device 100 may include a user interface 130. The user interface 130 may include one or more actuators (*e.g.*, buttons) for receiving user inputs and/or one or more visual indicators for providing user feedback. For example, the user interface 130 may include a toggle actuator and/or an intensity adjustment actuator (*e.g.*, such as a slider control or a pair of raise and lower buttons) for controlling the lighting loads 102, 103. The control circuit 115 may be configured to control the load control circuits 110, 120 to control the amount of power delivered to the lighting load 102, 103 in response to actuations of the actuators of the user interface 130. In addition, the user interface 130 may also include one or more light-emitting diodes (LEDs) for illuminating the visual indicators, for example, to provide a visual indication of a status and/or a present intensity of a lighting load, and/or a visual indication of a selected preset. For example, the user interface 130 may comprise a vertically-oriented linear array of visual indicators. The control circuit 115 may be coupled to the LEDs for illuminating the visual indicators of the user interface 130 to provide feedback.

[0024] The control circuit 115 may generate one or more drive signals. For example, the control circuit 115 may generate first and second drive signals V_{DR-1a} , V_{DR-1b} , respectively, that may be received by the first and second gate drive circuits 116, 118, respectively, for controlling the FETs Q112, Q114. The drive signals V_{DR-1a} , V_{DR-1b} may be provided to the first and second gate drive circuits 116, 118 of the first load control circuit 110 for adjusting the magnitude of a first dimmed-hot voltage V_{DH1} (*e.g.*, a first load voltage) generated across the lighting load 102 and/or the magnitude of the first load current I_{LOAD1} conducted through the lighting load 102, for example, to control the intensity of the lighting load 102 to a target intensity L_{TRGT1} , which may range between a high-end intensity L_{HE} (*e.g.*, 100%) and a low-end intensity L_{LE} (*e.g.*, 0.1-5%). The control circuit 115 may adjust a duty cycle (*e.g.*, an on time) of the drive signals V_{DR-1a} , V_{DR-1b} to adjust the intensity of the lighting load 102.

[0025] The control circuit 115 may generate the drive signals V_{DR-1a} , V_{DR-1b} to render the first FET Q112 to be non-conductive to prevent the first load current I_{LOAD1} from flowing through

the lighting load 102 during the positive half cycles, and the second FET Q114 to be non-conductive to prevent the first load current I_{LOAD1} from flowing through the lighting load 102 during the negative half cycles. When the first controllably conductive device (*e.g.*, the first FET Q112) is rendered conductive during the positive half cycles of the AC power source 104, the first load current I_{LOAD1} may be conducted through the drain-source channel of the first FET Q112 and the body diode of the second FET Q114. When the first controllably conductive device (*e.g.*, the second FET Q114) is rendered conductive during the negative half cycles of the AC power source 104, the load current I_{LOAD} may be conducted through the drain-source channel of the second FET Q114 and the body diode of the first FET Q112.

[0026] The first and the second gate drive circuits 116, 118 may receive the drive signals V_{DR-1a} , V_{DR-1b} from the control circuit 115 and use the drive signals V_{DR-1a} , V_{DR-1b} to control the magnitude of the first load current I_{LOAD1} conducted through the lighting load 102. For example, the first and second gate drive circuits 116, 118 may generate respective gate control signals in response to the drive signals V_{DR-1a} , V_{DR-1b} , and provide the respective gate control signals to the gates of the first and second FETs Q112, Q114 to render the FETs Q112, Q114 conductive and non-conductive and control the intensity of the lighting load 102. The gate drive circuits 116, 118 may include a wave-shaping circuit, a target voltage set circuit, an overcurrent protection circuit, an overcurrent detection circuit, and/or the like (*e.g.*, as described herein).

[0027] The first load control circuit 110 may include first and second feedback circuits, such as a first sense resistor R150 and a second sense resistor R152, respectively, that generate first and second feedback signals V_{FB-1a} , V_{FB-1b} indicative of a magnitude of the first load current I_{LOAD1} conducted through the FETs Q112, Q114. For example, the first sense resistor R150 may generate a first feedback signal V_{FB-1a} that is indicative of a magnitude of the first load current I_{LOAD1} conducted through the FET Q112 during the positive half cycles, while the second sense resistor R152 may generate a second feedback signal indicative V_{FB-1b} that is indicative of a magnitude of the first load current I_{LOAD1} conducted through the FET Q114 during the negative half cycles.

[0028] The first gate drive circuit 116 may receive the first feedback signal V_{FB-1a} and may generate the first gate control signal for controlling the first FET Q112 in response to the first drive signal V_{DR-1a} and the first feedback signal V_{FB-1a} . For example, the first gate drive circuit 116 may

be configured to adjust a magnitude of the first gate control signal in response to a magnitude of the first feedback signal V_{FB-1a} to adjust the magnitude of the first load current I_{LOAD1} towards a target current indicated by a magnitude of a target signal. Further, in some examples, the first gate drive circuit 116 may generate a shaped (*e.g.*, wave-shaped) target signal based on the drive signal V_{DR-1a} , and the first gate drive circuit 116 may generate the first gate control signal for the first FET Q112 in response to the shaped target signal and the first feedback signal V_{FB-1a} (*e.g.*, as described herein). For example, the control circuit 115 may be configured to generate the first drive signal V_{DR-1a} , and the first gate drive circuit 116 may be configured to shape (*e.g.*, start shaping) the target signal in response to the first drive signal V_{DR-1a} .

[0029] Similarly, the second gate drive circuit 118 may receive the second feedback signal V_{FB-1b} and may generate the second gate control signal for controlling the second FET Q114 in response to the second drive signal V_{DR-1b} and the second feedback signal V_{FB-1b} . For example, the second gate drive circuit 118 may be configured to adjust a magnitude of the second gate control signal in response to a magnitude of the second feedback signal V_{FB-1b} to adjust the magnitude of the first load current I_{LOAD1} towards a target current indicated by a magnitude of a target signal. Further, in some examples, the second gate drive circuit 118 may generate a shaped target signal based on the second drive signal V_{DR-1b} , and the second gate drive circuit 118 may generate the gate control signal for the second FET Q114 in response to the shaped target signal and the second feedback signal V_{FB-1b} (*e.g.*, as described herein). For example, the control circuit 115 may be configured to generate the second drive signal V_{DR-1b} , and the second gate drive circuit 118 may be configured to shape (*e.g.*, start shaping) the target signal in response to the second drive signal V_{DR-1b} .

[0030] The gate drive circuits 116, 118 may generate respective overcurrent detection signals V_{OC-1a} , V_{OC-1b} , which may be received by the control circuit 115. The gate drive circuits 116, 118 may be configured to detect an overcurrent condition in the respective FETs Q112, Q114 and generate the overcurrent detection signals V_{OC-1a} , V_{OC-1b} to indicate the overcurrent condition. The control circuit 115 may control the user interface 130 to provide feedback to a user to indicate the overcurrent condition (*e.g.*, by illuminating one or more visual indicators).

[0031] The first load control circuit 110 (*e.g.*, the first and second gate drive circuits 116, 118) may be configured to provide overcurrent protection for the load control device 100. In some

examples, the first and second gate drive circuits 116, 118 may be configured to detect an overcurrent condition in the respective FET Q112, Q114 in response to the respective gate control signal. Further, in some examples, the first gate drive circuit 116 may be configured to limit the magnitude of the first load current I_{LOAD1} to a maximum current level when the FET Q112 is conductive during the positive half cycles, detect an overcurrent condition when the magnitude of the first load current I_{LOAD1} is at the maximum current level, and render the FET Q112 non-conductive after a trip time period from when the overcurrent condition is detected. Similarly, the second gate drive circuit 118 may be configured to limit the magnitude of the first load current I_{LOAD1} to a maximum current level when the FET Q114 is conductive during the negative half cycles, detect an overcurrent condition when the magnitude of the first load current I_{LOAD1} is at the maximum current level, and render the FET Q114 non-conductive after a trip time period from when the overcurrent condition is detected. The length of the trip time period may be based on a parameter of the FET Q112, Q114, such as temperature of the semiconductor switch, a measured power of the semiconductor switch, or a drain source voltage of developed across the semiconductor switch. The length of the trip time period may be fixed. Further, in some examples, the gate drive circuits 116, 118 may be configured to render the FET Q112, Q114 non-conductive by driving the magnitude of the respective gate control signals to zero volts.

[0032] The control circuit 115 may also be configured to provide overcurrent protection (*e.g.*, redundant overcurrent protection) for the load control device 100 in response to the overcurrent detection signals V_{OC-1a} , V_{OC-1b} generated by the gate drive circuits 116, 118. For example, the control circuit 115 may be configured to control the drive signals V_{DR-1a} , V_{DR-1b} to render the FETs Q112, Q114 non-conductive when the either of the overcurrent detection signals V_{OC-1a} , V_{OC-1b} indicates an overcurrent condition. If the overcurrent condition persists repeatedly (*e.g.*, for a number of half cycles, such as 10 half cycles in a row), the control circuit 115 may render the FETs Q112, Q114 to turn off the lighting load 102 for a period of time (*e.g.*, a few seconds), and then attempt to turn the lighting load 102 back on.

[0033] The second load control circuit 120 may operate similar to the first load control circuit 110 as described herein. The second load control circuit 120 may comprise a second controllably conductive device having semiconductor switches, such as two field-effect transistors

(FETs) Q122, Q124. The FET Q122, Q124 may be coupled in anti-series connection between the hot terminal H and the dimmed-hot terminal DH2. The junction of the FETs Q122, Q124 may be coupled to circuit common. The second load control circuit 120 may also include a first gate drive circuit 126 (*e.g.*, a first closed-loop gate drive circuit) for controlling a first FET Q122, and a second gate drive circuit 128 (*e.g.*, a second closed-loop gate drive circuit) for controlling a second FET Q124. In some alternate examples, the second controllably conductive device of the second load control circuit 120 may comprise a single FET in a full-wave bridge rectifier and the second load control circuit 120 may comprise a single closed-loop gate drive circuit.

[0034] The control circuit 115 may control the second load control circuit 120 to conduct the second load current I_{LOAD2} through the second lighting load 103. For example, the control circuit 115 may generate first and second drive signals V_{DR-2a} , V_{DR-2b} , respectively, that may be received by the first and second gate drive circuits 126, 128, respectively, for controlling the FETs Q122, Q124. The drive signals V_{DR-2a} , V_{DR-2b} may be provided to the first and second gate drive circuits 126, 128 of the second load control circuit 120 for adjusting the magnitude of a second dimmed-hot voltage V_{DH2} (*e.g.*, a first load voltage) generated across the lighting load 103 and/or the magnitude of the second load current I_{LOAD2} conducted through the lighting load 103, for example, to control the intensity of the lighting load 103 to a target intensity L_{TRGT2} , which may range between a high-end intensity L_{HE} (*e.g.*, 100%) and a low-end intensity L_{LE} (*e.g.*, 0.1-5%). The control circuit 115 may adjust a duty cycle (*e.g.*, an on time) of the drive signals V_{DR-2a} , V_{DR-2b} to adjust the intensity of the lighting load 103.

[0035] The control circuit 115 may generate the drive signals V_{DR-2a} , V_{DR-2b} to render the first FET Q122 to be non-conductive to prevent the second load current I_{LOAD2} from flowing through the lighting load 103 during the positive half cycles, and the second FET Q124 to be non-conductive to prevent the second load current I_{LOAD2} from flowing through the lighting load 103 during the negative half cycles. When the second controllably conductive device (*e.g.*, the first FET Q122) is rendered conductive during the positive half cycles of the AC power source 104, the second load current I_{LOAD2} may be conducted through the drain-source channel of the first FET Q122 and the body diode of the second FET Q124. When the second controllably conductive device (*e.g.*, the second FET Q124) is rendered conductive during the negative half cycles of the AC power source

104, the second load current I_{LOADs} may be conducted through the drain-source channel of the second FET Q124 and the body diode of the first FET Q122.

[0036] The first and the second gate drive circuits 126, 128 may receive the drive signals V_{DR-2a} , V_{DR-2b} from the control circuit 115 and use the drive signals V_{DR-2a} , V_{DR-2b} to control the magnitude of the second load current I_{LOAD2} conducted through lighting load 103. For example, the first and second gate drive circuits 126, 128 may generate respective gate control signals in response to the drive signals V_{DR-2a} , V_{DR-2b} , and provide the respective gate control signals to the gates of the first and second FETs Q122, Q124 to render the FETs Q122, Q124 conductive and non-conductive and control the intensity of the lighting load 103. The gate drive circuits 126, 128 may include a wave-shaping circuit, a target voltage set circuit, an overcurrent protection circuit, an overcurrent detection circuit, and/or the like (*e.g.*, as described herein).

[0037] The second load control circuit 120 may include first and second feedback circuits, such as a first sense resistor R154 and a second sense resistor R156, respectively, that generate first and second feedback signals V_{FB-2a} , V_{FB-2b} indicative of a magnitude of the second load current I_{LOAD2} conducted through the FETs Q122, Q124. For example, the first sense resistor R154 may generate a first feedback signal V_{FB-2a} that is indicative of a magnitude of the second load current I_{LOAD2} conducted through the FET Q122 during the positive half cycles, while the second sense resistor R156 may generate a second feedback signal indicative V_{FB-2b} that is indicative of a magnitude of the second load current I_{LOAD2} conducted through the FET Q124 during the negative half cycles.

[0038] The first gate drive circuit 126 may receive the first feedback signal V_{FB-2a} and may generate a gate control signal for controlling the first FET Q122 in response to the first drive signal V_{DR-2a} and the first feedback signal V_{FB-2a} . For example, the first gate drive circuit 126 may be configured to adjust a magnitude of the first gate control signal in response to a magnitude of the first feedback signal V_{FB-2a} to adjust the magnitude of the second load current I_{LOAD2} towards a target current indicated by a magnitude of a target signal. Further, in some examples, the first gate drive circuit 126 may generate a shaped target signal based on the drive signal V_{DR-2a} , and the first gate drive circuit 126 may generate the first gate control signal for the first FET Q122 in response to the shaped target signal and the first feedback signal V_{FB-2a} (*e.g.*, as described herein). For example, the

control circuit 115 may be configured to generate the first drive signal V_{DR-2a} , and the first gate drive circuit 126 may be configured to shape (*e.g.*, start shaping) the target signal in response to the first drive signal V_{DR-2a} .

[0039] Similarly, the second gate drive circuit 128 may receive the second feedback signal V_{FB-2b} and may generate the second gate control signal for controlling the second FET Q124 in response to the second drive signal V_{DR-2b} and the second feedback signal V_{FB-2b} . For example, the second gate drive circuit 128 may be configured to adjust a magnitude of the second gate control signal in response to a magnitude of the second feedback signal V_{FB-2b} to adjust the magnitude of the second load current I_{LOAD2} towards a target current indicated by a magnitude of a target signal. Further, in some examples, the second gate drive circuit 128 may generate a shaped target signal based on the second drive signal V_{DR-2b} , and the second gate drive circuit 128 may generate the gate control signal for the second FET Q124 in response to the shaped target signal and the second feedback signal V_{FB-2b} (*e.g.*, as described herein). For example, the control circuit 115 may be configured to generate the second drive signal V_{DR-2b} , and the second gate drive circuit 128 may be configured to shape (*e.g.*, start shaping) the target signal in response to the second drive signal V_{DR-2b} .

[0040] The gate drive circuits 126, 128 may generate respective overcurrent signals V_{OC-2a} , V_{OC-2b} , which may be received by the control circuit 115. The gate drive circuits 126, 128 may be configured to detect an overcurrent condition in the respective FETs Q122, Q124 and generate the overcurrent detection signals V_{OC-2a} , V_{OC-2b} to indicate the overcurrent condition. The control circuit 115 may control the user interface 130 to provide feedback to a user to indicate the overcurrent condition (*e.g.*, by illuminating one or more visual indicators).

[0041] The second load control circuit 120 (*e.g.*, the first and second gate drive circuits 126, 128) may be configured to provide overcurrent protection for the load control device 100. In some examples, the first and second gate drive circuits 126, 128 may be configured to detect an overcurrent condition in the semiconductor switch Q122, Q124 in response to their respective gate control signals. Further, in some examples, the first gate drive circuit 126 may be configured to limit the magnitude of the second load current I_{LOAD2} to a maximum current level when the semiconductor switch Q122 is conductive during the positive half cycles, detect an overcurrent condition when the

magnitude of the second load current I_{LOAD2} is at the maximum current level, and render the semiconductor switch Q122 non-conductive after a trip time period from when the overcurrent condition is detected. Similarly, the second gate drive circuit 128 may be configured to limit the magnitude of the second load current I_{LOAD2} to a maximum current level when the semiconductor switch Q124 is conductive during the negative half cycles, detect an overcurrent condition when the magnitude of the second load current I_{LOAD2} is at the maximum current level, and render the semiconductor switch Q124 non-conductive after a trip time period from when the overcurrent condition is detected. The length of the trip time period may be based on a parameter of the semiconductor switch Q122, Q124, such as temperature of the semiconductor switch, a measured power of the semiconductor switch, or a drain source voltage of developed across the semiconductor switch. Further, in some examples, the gate drive circuits 126, 128 may be configured to render the semiconductor switches Q122, Q124 non-conductive by driving the magnitude of the respective gate control signals to zero volts.

[0042] The control circuit 115 may also be configured to provide overcurrent protection (*e.g.*, redundant overcurrent protection) for the load control device 100 in response to the overcurrent detection signals V_{OC-2a} , V_{OC-2b} generated by the gate drive circuits 126, 128. For example, the control circuit 115 may be configured to control the drive signals V_{DR-2a} , V_{DR-2b} to render the FETs Q122, Q124 non-conductive when the either of the overcurrent detection signals V_{OC-2a} , V_{OC-2b} indicates an overcurrent condition. If the overcurrent condition persists repeatedly (*e.g.*, for a number of half cycles, such as 10 half cycles in a row), the control circuit 115 may render the FETs Q122, Q124 to turn off the lighting load 103 for a period of time (*e.g.*, a few seconds), and then attempt to turn the lighting load 103 back on.

[0043] The load control device 100 may include a power supply 140. The power supply 140 may receive the AC mains line voltage V_{AC} and may generate a direct-current (DC) supply voltage V_{CC} (*e.g.*, approximately 3.3V). For example, the power supply 140 may power the control circuit 115 and/or other low-voltage circuits of the load control device 100. Each of the first and second load control circuits 110, 120 may comprise a respective power supply (not shown) configured to generate respective supply voltages (*e.g.*, approximately 15V) for driving the respective

semiconductor switches Q112, Q114, Q122, Q124 (*e.g.*, as will be described in greater detail below with reference to FIG. 3).

[0044] The control circuit 115 may be configured to determine times of zero-crossing points of the AC mains line voltage V_{AC} of the AC power source 104. For example, the load control device 100 may comprise a zero-crossing detect circuit (not shown) that may be coupled to the hot terminal H and the neutral terminal N, and generates a zero-cross signal that indicates the zero-crossing points of the AC mains line voltage V_{AC} . The control circuit 115 may then render the semiconductor switches Q112, Q114, Q122, Q124 conductive and/or non-conductive at predetermined times (*e.g.*, at a firing time or firing angle) relative to the zero-crossing points of the AC mains line voltage V_{AC} (*e.g.*, as determined from the zero-cross signal) to generate a phase-control dimmed-hot voltage V_{PC} using a phase-control dimming technique (*e.g.*, a forward phase-control dimming technique and/or a reverse phase-control dimming technique). For example, the control circuit 115 may use the forward phase-control dimming technique to control inductive loads and may use the reverse phase-control dimming technique to control capacitive loads. Examples of dimmers are described in greater detail in commonly-assigned U.S. Patent No. 7,242,150, issued July 10, 2007, entitled DIMMER HAVING A POWER SUPPLY MONITORING CIRCUIT; U.S. Patent No. 7,546,473, issued June 9, 2009, entitled DIMMER HAVING A MICROPROCESSOR-CONTROLLED POWER SUPPLY; and U.S. Patent No. 8,664,881, issued March 4, 2014, entitled TWO-WIRE DIMMER SWITCH FOR LOW-POWER LOADS, the entire disclosures of which are incorporated by reference herein.

[0045] The control circuit 115 may be configured to adjust a firing time (*e.g.*, a phase angle) of the controllably conductive devices of the load control circuits 110, 120 each half cycle to control the amount of power delivered to the lighting load 102, 103 and to control the intensity of the lighting loads 102, 103 toward respective target intensities. The control circuit 115 may be configured to control the semiconductor switches Q112, Q114, Q122, Q124 using the forward phase-control dimming technique and/or the reverse phase-control dimming technique. When using the forward phase-control dimming technique, the control circuit 115 may render one or more of the semiconductor switches Q112, Q114, Q122, Q124 non-conductive (*e.g.*, to cause the controllably conductive devices 110, 120 to be non-conductive) at the beginning of each half cycle of the AC

mains line voltage, and then render one or more of the semiconductor switches Q112, Q114, Q122, Q124 conductive (*e.g.*, to cause the controllably conductive devices 110, 120 to be conductive) at a firing time during the half cycle after which the controllably conductive devices 110, 120 may remain conductive until the end of the half cycle. When using the reverse phase-control dimming technique, the control circuit 115 may render one or more of the semiconductor switches Q112, Q114, Q122, Q124 conductive (*e.g.*, to cause the controllably conductive devices 110, 120 to be conductive) at the beginning of each half cycle of the AC mains line voltage, and then render one or more of the semiconductor switches Q112, Q114, Q122, Q124 non-conductive (*e.g.*, to cause the controllably conductive devices 110, 120 to be non-conductive) at a firing time during the half cycle after which the controllably conductive devices 110, 120 may remain non-conductive until the end of the half cycle.

[0046] FIG. 2 is a block diagram of the load control device 100 in an alternate configuration. The first and second dimmed-hot terminals DH1, DH2 may be coupled together to a single lighting load 104. For example, the lighting load 104 may have a higher power rating than the lighting loads 102, 104 of FIG. 1, and may conduct a load current I_{LOAD} having a higher magnitude through the load control device 100. Because the first and second dimmed-hot terminals DH1, DH2 are coupled together, the first controllably conductive device of the first load control circuit 110 and the second controllably conductive device of the second load control circuit 120 may be electrically coupled in parallel with each other, and may each conduct at least a portion of the load current I_{LOAD} through the lighting load 104. The control circuit 115 may control the first controllably conductive device 110 and the second controllably conductive device 120 together to control the lighting load 104. For example, the control circuit 115 may generate the first drive signals V_{DR-1a} , V_{DR-2a} , such that the first drive signals V_{DR-1a} , V_{DR-2a} are the same, for example, having the same duty cycles and in phase with each other (*e.g.*, synchronized to the AC mains line voltage V_{AC}). In addition, the control circuit 115 may generate the second drive signals V_{DR-1b} , V_{DR-2b} , such that the second drive signals V_{DR-1b} , V_{DR-2b} are also the same, for example, having the same duty cycles and in phase with each other (*e.g.*, synchronized to the AC mains line voltage V_{AC}). Because the first and second controllably conductive devices are coupled in parallel with each other and share the load current I_{LOAD} , the load control device may be able to control lighting loads having a higher power rating

than when the lighting loads are coupled individually coupled to the load control circuits 110, 120 as shown in FIG. 1.

[0047] FIG. 3 is a block diagram of an example gate drive circuit 300 of a load control circuit 302 of a load control device, such as the gate drive circuits 116, 118, 126, 128 shown in FIGs. 1 and 2. As described herein, the gate drive circuit 300 may monitor a load current I_{LOAD} conducted through an electrical load, such as a lighting load (*e.g.*, lighting loads 102, 103, 104 shown in FIGs. 1 and 2), and may generate a signal (*e.g.*, a gate control signal V_{GC}) to control a semiconductor switch, such as a FET Q330 (*e.g.*, FETs Q112, Q114, Q122, Q124 shown in FIGs. 1 and 2), to control the amount of power delivered to an electrical load.

[0048] The gate drive circuit 300 may receive a signal, such as a drive signal V_{DR} from a control circuit (*e.g.*, such as the drive signals V_{DR-1a} , V_{DR-1b} , V_{DR-2a} , V_{DR-2b} generated by the control circuit 115 shown in FIG. 1 or the control circuit 215 shown in FIG. 2). The gate drive circuit 300 may be configured to render the FET Q330 conductive and non-conductive in response to the drive signal V_{DR} . The gate drive circuit 300 may generate a target signal V_{TRGT} in response to the drive signal V_{DR} received from the control circuit. The target signal V_{TRGT} may be shaped, *e.g.*, having a magnitude that adjusts with respect to time over a period of time. The period of time may be a preconfigured period of time and may allow the gate drive circuit 300 to have smooth turn-on and/or turn-off transitions. The gate drive circuit 300 may generate the target signal V_{TRGT} (*e.g.*, using a turn-on signal V_{T-ON} , a turn-off signal V_{T-OFF} , etc.) by adjusting a magnitude of the target signal V_{TRGT} over the period of time, for example, as described herein.

[0049] The gate drive circuit 300 may receive a feedback signal V_{I-FB} that may have a magnitude that indicates a magnitude of the load current I_{LOAD} conducted through the FET Q330 (*e.g.*, and conducted through the electrical load). For example, the load control circuit 302 may include a feedback circuit, such as a sense resistor R332, that generates the feedback signal V_{I-FB} . The sense resistor R332 may be coupled between the FET Q330 and circuit common, and may conduct the load current I_{LOAD} . The feedback signal V_{I-FB} may be generate across the sense resistor R332 and may be referenced to as circuit common of the gate drive circuit 300. The magnitude of the feedback signal V_{I-FB} (*e.g.*, the voltage generated across the sense resistor R332) may be proportional to the magnitude of the load current I_{LOAD} conducted through the FET Q330 (*e.g.*,

dependent upon a resistance of the sense resistor R332). The gate drive circuit 300 may generate the gate control signal V_{GC} in response to the target signal V_{TRGT} and the feedback signal V_{I-FB} . When the FET Q330 is conductive, the gate drive circuit 300 may control the FET Q330 in the linear region to adjust an impedance (*e.g.*, a drain-source impedance) of the FET Q330 based on the gate control signal V_{GC} . The gate drive circuit 300 may control the FET Q330 to adjust the impedance of the FET Q330 in response to the feedback signal V_{I-FB} to control the magnitude of the load current I_{LOAD} towards the target signal V_{TRGT} .

[0050] The gate drive circuit 300 may comprise a step-up circuit 310, a turn-on wave-shaping circuit 312, and a turn-off wave-shaping circuit 314. The step-up circuit 310, the turn-on wave-shaping circuit 312, and/or the turn-off wave-shaping circuit 314 may receive the drive signal V_{DR} from the control circuit. In addition, the drive signal V_{DR} may be coupled to the step-up circuit 310, the turn-on wave-shaping circuit 312, and/or the turn-off wave-shaping circuit 314 via an optocoupler (not shown), such that the control circuit is electrically isolated from the gate drive circuit 300.

[0051] The turn-on wave-shaping circuit 312 may receive the drive signal V_{DR} from the control circuit and may generate a turn-on signal V_{T-ON} . For example, the turn-on wave-shaping circuit 312 may shape (*e.g.*, wave-shape) the turn-on signal V_{T-ON} during a turn-on period T_{T-ON} (*e.g.*, approximately 50 μ sec). The turn-on wave-shaping circuit 312 may shape (*e.g.*, begin shaping) the turn-on signal V_{T-ON} at a time during the turn-on period T_{T-ON} (*e.g.*, at the beginning time of the turn-on period T_{T-ON}). The turn-on wave-shaping circuit 312 may provide the turn-on signal V_{T-ON} to a target voltage set circuit 316, which may use the turn-on signal V_{T-ON} to generate the target signal V_{TRGT} . The turn-on wave-shaping circuit 312 may shape the turn-on signal V_{T-ON} with a preconfigured shape, such as an S-shape. For example, the turn-on wave-shaping circuit 312 may wave-shape the turn-on signal V_{T-ON} with a first shape during a first portion of the turn-on period T_{T-ON} and wave-shape the turn-on signal V_{T-ON} with a second shape during a second portion of the turn-on period T_{T-ON} so that the target signal V_{TRGT} has a preconfigured shape, such as an S-shape. Although illustrated as an S-shape, the turn-on wave-shaping circuit 312 may shape the turn-on signal V_{T-ON} with any shape (*e.g.*, such as a ramp). The turn-on wave-shaping circuit 312 may control the magnitude of the turn-on signal V_{T-ON} to a rated current magnitude V_{I-RTD} (*e.g.*, a rated

current value) at the end of the turn-on period T_{T-ON} . For example, the rated current magnitude V_{I-RTD} may be approximately 7.5 volts.

[0052] The step-up circuit 310 may receive the drive signal V_{DR} from the control circuit and provide a step signal V_{STEP} to the target voltage set circuit 316, which may use the step signal V_{STEP} to generate the target signal V_{TRGT} . For example, the step signal V_{STEP} may be similar to the drive signal V_{DR} received from the control circuit. The step-up circuit 310 may drive the magnitude of the step signal V_{STEP} high (e.g., towards the isolated supply voltage V_{SUP}) after a delay period T_{DELAY} after the drive signal V_{DR} is driven high (e.g., towards the DC supply voltage V_{CC}).

[0053] The gate drive circuit 300 may also include a drain voltage sense circuit 328 that is coupled to the FET Q330 (e.g., to the drain of the FET Q330). The drain voltage sense circuit 328 may detect a magnitude of a voltage developed across the FET Q330. The drain voltage sense circuit 328 may provide a second feedback signal (e.g., a drain voltage sense signal V_{DV}) to the turn-off wave-shaping circuit 314. The drain voltage signal V_{DV} may indicate the magnitude of the voltage across the FET Q330.

[0054] The turn-off wave-shaping circuit 314 may receive the drive signal V_{DR} from the control circuit and the drain voltage signal V_{DV} from the drain voltage sense circuit 328. The turn-off wave-shaping circuit 314 may generate a turn-off signal V_{T-OFF} in response to the drive signal V_{DR} and the drain voltage signal V_{DV} . For example, the turn-off wave-shaping circuit 314 may shape the turn-off signal V_{T-OFF} over a period of time, such as during a turn-off period T_{T-OFF} , to generate the turn-off signal V_{T-OFF} . The turn-off wave-shaping circuit 314 may shape the turn-off signal V_{T-OFF} in response to receiving the drain voltage signal V_{DV} from the drain voltage sense circuit 328. For example, upon receiving the drain voltage signal V_{DV} , the turn-off wave-shaping circuit 314 may shape (e.g., begin to shape) the turn-off signal V_{T-OFF} . The turn-off wave-shaping circuit 314 may provide the turn-off signal V_{T-OFF} to a target voltage set circuit 316, which may use the turn-off signal V_{T-OFF} to generate the target signal V_{TRGT} . The turn-off wave-shaping circuit 314 may shape the turn-off signal V_{T-OFF} with a preconfigured shape, such as a S-shape, so that the turn-off signal V_{T-OFF} also has the preconfigured shape. For example, the turn-off wave-shaping circuit 314 may shape the turn-off signal V_{T-OFF} with a first shape during a first portion of the turn-off period T_{T-OFF} , and may shape the turn-off signal V_{T-OFF} with a second shape during a second portion

of the turn-off period T_{T-OFF} so that the target signal V_{TRGT} has a preconfigured shape, such as an S-shape. Although illustrated as an S-shape, the turn-off wave-shaping circuit 315 may shape the turn-off signal V_{T-OFF} with any shape (*e.g.*, such as a ramp).

[0055] The target voltage set circuit 316 may receive the turn-on signal V_{T-ON} from the turn-on wave-shaping circuit 312, the turn-off signal V_{T-OFF} from the turn-off wave-shaping circuit 314, and/or the step signal V_{STEP} from the step-up circuit 310. For example, the target voltage set circuit 316 may act as a combining circuit and combine one or more of the turn-on signal V_{T-ON} from the turn-on wave-shaping circuit 312, the turn-off signal V_{T-OFF} from the turn-off wave-shaping circuit 314, and/or the step signal V_{STEP} from the step-up circuit 310 to generate the target signal V_{TRGT} . The target signal V_{TRGT} may be used to control the FET Q330.

[0056] When rendering the FET Q330 conductive, the control circuit may be configured to drive the drive signal V_{DR} high (*e.g.*, towards the DC supply voltage V_{CC}) to generate a rising edge in the drive signal V_{DR} . In response to the rising edge of the drive signal V_{DR} , the target voltage set circuit 316 may set the target voltage V_{TRGT} to be equal to the turn-on signal V_{T-ON} during the turn-on period T_{T-ON} . As noted above, the turn-on signal V_{T-ON} may be shaped. The target voltage set circuit 316 may set the magnitude of the target voltage V_{TRGT} to be equal to the rated current magnitude V_{I-RTD} at the end of the turn-on period T_{T-ON} . When the magnitude of the target signal V_{TRGT} is equal to the rated current magnitude V_{I-RTD} at the end of the turn-on period T_{T-ON} , the gate drive circuit 300 may attempt to control the magnitude of the load current I_{LOAD} to a maximum rated current I_{RATED} (*e.g.*, approximately 10A).

[0057] After the delay period T_{DELAY} , the target voltage set circuit 316 may set the target signal V_{TRGT} to be equal to a maximum current magnitude V_{I-MAX} (*e.g.*, a maximum current value) in response to the step signal V_{STEP} (*e.g.*, to be equal to the magnitude of the step signal V_{STEP}). For example, the maximum current magnitude V_{I-MAX} may be approximately 15 volts). The delay period T_{DELAY} may be approximately equal to (*e.g.*, equal to) the turn-on period T_{T-ON} , such that the target voltage signal T_{TRGT} is set to the magnitude of the step signal V_{STEP} after the turn-on period T_{T-ON} . When the magnitude of the target signal V_{TRGT} is equal to the maximum current magnitude V_{I-MAX} after the turn-on period T_{T-ON} , the gate drive circuit 300 may attempt to control the magnitude of the load current I_{LOAD} to a maximum current level I_{MAX} (*e.g.*, approximately 20A).

[0058] When rendering the FET Q330 non-conductive, the control circuit may be configured to drive the drive signal V_{DR} low (*e.g.*, to approximately circuit common) to generate a falling edge in the drive signal V_{DR} . In response to the falling edge of the drive signal V_{DR} , the gate drive circuit 300 may be configured to decrease (*e.g.*, start decreasing) the magnitude of the target voltage V_{TRGT} with respect to time. More specifically, when turning-off, the target voltage set circuit 316 may set the target voltage V_{TRGT} to be equal to the turn-off signal V_{T-OFF} . For example, the turn-off wave-shaping circuit 314 may set the magnitude of the turn-off signal V_{T-OFF} to a predetermined value, *e.g.*, approximately the rated current magnitude V_{I-RTD} , which may be approximately 50% of the maximum current magnitude V_{I-MAX} (*e.g.*, from approximately 15V to 7.5V). Thereafter, the turn-off wave-shaping circuit 314 may gradually decrease the magnitude of the turn-off signal V_{T-OFF} until the turn-off wave-shaping circuit 314 the drain voltage signal V_{DV} from the drain voltage sense circuit 328 indicates that the voltage across the FET 330 is starting to rise (*e.g.*, has exceeding a drain voltage threshold V_{TH} indicating that the FET is starting to become non-conductive). Once the magnitude of the voltage developed across the FET Q330 as indicated by the drain voltage signal V_{DV} exceeds the drain voltage threshold V_{TH} , the turn-off wave-shaping circuit 314 may begin to shape the turn-off signal V_{T-OFF} from the present magnitude (*e.g.*, the magnitude at the time the drain voltage signal V_{DV} indicates that the magnitude of the voltage across the FET 330 has exceeded the drain voltage threshold V_{TH}) to zero volts. The target voltage set circuit 316 may set the target voltage V_{TRGT} to be equal to the turn-off signal V_{T-OFF} .

[0059] The gate drive circuit 300 may include an operational amplifier circuit 318. The operational amplifier circuit 318 may having a non-inverting input configured to receive the target signal V_{TRGT} from the target voltage set circuit 316 and an inverting input configured to receive the feedback signal V_{I-FB} from the sense resistor R332. The operational amplifier circuit 318 may generate the gate control signal V_{GC} at an output based on the target signal V_{TRGT} and the feedback signal V_{I-FB} . For example, the operational amplifier circuit 318 may adjust the gate control signal V_{GC} to control the FET Q330 and thus control the magnitude of the load current I_{LOAD} towards a target current indicated by the magnitude of the target signal V_{TRGT} . The operational amplifier circuit 318 may be referenced to circuit common of the gate drive circuit 300 (*e.g.*, to which the feedback signal V_{I-FB} is referenced). As previously mentioned, the magnitude of the feedback signal V_{I-FB} may be proportional to the magnitude of the load current I_{LOAD} . Accordingly, the operational

amplifier circuit 318 may control the magnitude of the gate control signal V_{GC} in response to the magnitude of the load current I_{LOAD} . Some lighting loads, such as LED light sources, may be capacitive loads, which may cause changes in a load voltage (*e.g.*, a dimmed-hot voltage) across the lighting load that are not representative of the magnitude of the load current I_{LOAD} (*e.g.*, proportional to the magnitude of the load current I_{LOAD}). Since both the sense resistor R332 and the operational amplifier circuit 318 are referenced to circuit common, the operational amplifier circuit 318 may be responsive to (*e.g.*, only responsive to) the magnitude of the load current I_{LOAD} and not influenced by the magnitude of the load voltage across the lighting load.

[0060] The gate drive circuit 300 may include a buffer circuit 326. The buffer circuit 326 may be coupled in series between the output of the operational amplifier circuit 318 and the gate of the FET Q330. The buffer circuit 326 may receive the control signal V_{GC} from the voltage amplifier circuit 318 and may buffer the control signal V_{GC} to generate a gate voltage V_G . The gate signal V_G may control conductivity of the FET Q330. For example, the gate signal V_G , via the gate control signal V_{GC} , may render the FET Q330 conductive and non-conductive. In some examples, the gate drive circuit 300 may not include the buffer circuit 326.

[0061] The gate drive circuit may include an overcurrent detection circuit 322 and an overcurrent protection circuit 324. The overcurrent detection circuit 322 may detect an overcurrent condition. For example, the overcurrent detection circuit 322 may detect the overcurrent condition when the load current I_{LOAD} (*e.g.*, the magnitude of the load current) conducted through the FET Q330 (*e.g.*, and through the electrical load) reaches the maximum current level I_{MAX} . Since the magnitude of the gate control signal V_{GC} indicates the desired magnitude of the load current I_{LOAD} , the overcurrent detection circuit 322 may receive the gate control signal V_{GC} and may determine whether an overcurrent condition is occurring in response to the magnitude of the gate control signal V_{GC} . The overcurrent detection circuit 322 may receive the step up signal V_{STEP} and may begin to monitor for the overcurrent condition in response to the step up signal V_{STEP} (*e.g.*, after the step up signal V_{STEP} is driven high when rendering the FET Q330 conductive). For example, the overcurrent detection circuit 322 may determine that an overcurrent condition has occurred when the gate control signal V_{GC} is at the maximum current magnitude V_{I-MAX} for a predetermined period of time.

[0062] The overcurrent detection circuit 322 may generate a signal (*e.g.*, an overcurrent detection signal V_{OCD}) that may be received by the control circuit. When the overcurrent detection circuit 322 detects an overcurrent condition, the overcurrent detection circuit 322 may drive the magnitude of the overcurrent detect signal V_{OCD} high to indicate the overcurrent condition to the control circuit. For example, the overcurrent detection signal V_{OCD} may be coupled to the control circuit via an optocoupler (not shown). The control circuit may use the overcurrent detect signal V_{OCD} to provide feedback to a user regarding the overcurrent condition. For example, the load control device 100 of FIG. 1 may provide feedback to the user about the overcurrent condition via the user interface 130.

[0063] The overcurrent protection circuit 324 may receive the overcurrent detect signal V_{OCD} from the overcurrent detection circuit 322, the drain voltage signal V_{DV} from the drain voltage sense circuit 328, and the drive signal V_{DR} from the control circuit. The overcurrent protection circuit 324 may control the voltage amplifier circuit 318 to render the FET Q330 non-conductive after a trip time period T_{TRIP} from when the overcurrent condition is detected (*e.g.*, from when the overcurrent detect signal V_{OCD} is driven high by the overcurrent protection circuit 324). For example, the overcurrent protection circuit 324 may generate an overcurrent protection signal V_{OCP} that may be received by the target voltage set circuit 316. When the overcurrent protection circuit 324 detects that the magnitude of the gate control signal V_{GC} is at the maximum current magnitude V_{I-MAX} for a trip time period T_{TRIP} after the overcurrent condition is detected, the overcurrent protection circuit 324 may control the overcurrent protection signal V_{OCP} to render the FET Q330 non-conductive. The overcurrent protection circuit 324 may render the FET Q330 non-conductive by controlling the target voltage set circuit 316 to set the magnitude of the target voltage V_{TRGT} to zero volts to cause the operational amplifier circuit 318 to drive the magnitude of the gate control signal V_{GC} to zero volts when the overcurrent condition is detected. After the overcurrent protection circuit 324 has caused the operational amplifier circuit 318 to drive the magnitude of the gate control signal V_{GC} to zero volts, the overcurrent protection circuit 324 may remain latched in the overcurrent state. The overcurrent protection circuit 324 may be reset from being latched in the overcurrent state in response to the drive signal V_{DR} (*e.g.*, when the drive signal V_{DR} is driven low to render the FET Q330 non-conductive).

[0064] The overcurrent protection circuit 324 may determine the length of the trip time period based on a parameter of the FET Q330. The length of the trip time period may be associated with a safe operating area of the FET Q330. For example, the parameter of the FET Q330 may include a temperature of the FET, a power dissipation of the FET, a voltage developed across the FET, and/or the like. Based on the parameter, the overcurrent protection circuit 324 may determine the length of trip time period to render the FET Q330 non-conductive after the overcurrent condition is detected. For example, the overcurrent protection circuit 324 may be configured to determine the magnitude of the voltage developed across the FET Q330 in response to drain voltage signal V_{DV} from the drain voltage sense circuit 328.

[0065] The length of the trip time period may be inversely proportional to the parameter of the FET Q330. For example, the overcurrent protection circuit 324 may have a shorter length of the trip time period when the parameter (*e.g.*, temperature, power, and/or voltage) is high, and may have a longer length of the trip time period when the parameter (*e.g.*, temperature, power, and/or voltage) is low. Accordingly, the overcurrent protection circuit 324 may render the FET Q330 conductive faster by having a shorter length of the trip time period when, for example, an overcurrent condition may be occurring. In addition, the overcurrent protection circuit 324 may render the FET Q330 conductive slower by having a longer length of the trip time period (*e.g.*, to allow for conduction of inrush current for a longer period of time). By allowing the FET Q330 to be conductive in a current half cycle for a longer period of time to conduct inrush current, the gate drive circuit 300 may charge an input capacitance of the electrical load to a greater level and reduce the amount of inrush current that may be conducting during the next half cycle.

[0066] The gate drive circuit 300 may include an isolated power supply 320. The isolated power supply 320 may generate an isolated supply voltage V_{SUP} (*e.g.*, approximately 15 V) for providing power to the gate drive circuit 300 and drive the FET Q330. The isolated power supply 320 may be independent from a power supply used for the remaining components of the load control device, such as the power supply 140 shown in FIGs. 1 and 2. For example, each of the controllably conductive devices 110, 120 shown in FIGs 1 and 2 may comprise an individual isolated power supply. Alternatively, the load control device may include a single power supply, and as such, the isolated power supply 320 may be omitted.

[0067] When the load control device comprises multiple load control circuits (*e.g.*, such as the first and second load control circuits 110, 120 of the load control device 100), a single lighting load may be connected to two or more the dimmed-hot terminals (*e.g.*, as shown in FIG. 2), such that the load control circuits are coupled in parallel and share the load current (*e.g.*, may each conduct at least a portion of a load current I_{LOAD} through the lighting load). This may allow the load control device to control a lighting load having a high power rating than when lighting loads are individually coupled to the dimmed-hot terminals (*e.g.*, as shown in FIG. 1).

[0068] Each of the multiple load control circuit includes respective closed-loop drive circuit for each of the semiconductor switches. The closed-loop drive circuits each operate to limit the magnitude of the portion of the load current being conducted through the respective semiconductor switch to the maximum current level I_{MAX} (*e.g.*, as described above with reference to the gate drive circuit 300 of FIG. 3). The control circuit 115 may generate respective drive signals to control the respective semiconductor switches of each of the load control circuits in unison (*e.g.*, with identical drive signals as described above with reference to FIG. 2). However, due to tolerances of the components of the gate drive circuits, there may be different hardware delays between when the drive signals are driven high to render the semiconductor switches conductive and each of semiconductor switches are rendered conductive. For example, if the first FET Q112 of the first load control circuit 110 becomes conductive before (*e.g.*, even slightly before) the FET Q122 of the second load control circuit 120, the FET Q112 may attempt to conduct (*e.g.*, briefly conduct) all of the load current I_{LOAD} (*e.g.*, which may be very large, particularly during an inrush current condition). Because the first closed-loop gate circuit 116 may limit the magnitude of the load current I_{LOAD} conducted through the first FET Q112 to the maximum current level I_{MAX} , the first FET Q112 may not be damaged and may continue to conduct (*e.g.*, briefly conduct) the load current I_{LOAD} at the maximum current level I_{MAX} until the second FET Q112 becomes conductive.

[0069] FIG. 4 shows examples of waveforms that illustrate an operation of a load control device (*e.g.*, the load control device 100 shown in FIGs. 1 and 2) using a forward phase-control dimming technique. As described herein, the load control device may receive an AC voltage from an AC power source and may generate a dimmed-hot voltage V_{DH} at a dimmed-hot terminal of the load control device. Using the forward phase-control dimming technique and as shown in FIG. 4, a

control circuit may render a controllably conductive device non-conductive at the beginning of each half cycle (*e.g.*, during a non-conductive period T_{NC}), render the controllably conductive device conductive at a firing time during the half cycle, and maintain the controllably conductive device non-conductive until the end of the half cycle (*e.g.*, during a conductive period T_{CON}). For example, the controllably conductive device may comprise two semiconductor switches, such as in anti-series connection. Further, it should be appreciated that the slope of the dimmed-hot voltage V_{DH1} when transitioning from and to zero volts as shown in FIGs. 4-9 is exaggerated for illustrated purposes.

[0070] The control circuit may generate a drive signal to control the conductivity of the controllably conductive device. For example, the control circuit may generate a first drive signal V_{DR-1a} to render a first semiconductor switch (*e.g.*, the first FET Q112 of the first controllably conductive device 110) conductive during the positive half cycles, and may generate a second drive signal V_{DR-1b} to render a second semiconductor switch (*e.g.*, the second FET Q114 of the first controllably conductive device 120) conductive during the negative half cycles. The first and second drive signals V_{DR-1a} , V_{DR-1b} may be pulse-width modulated signals.

[0071] The load control device may generate target signals (*e.g.*, a first target signal $V_{TRGT-1a}$ and a second target signal $V_{TRGT-1b}$) in response to the control circuit. For example, as described herein, a first gate drive circuit of the load control device (*e.g.*, the first gate drive circuit 116) may receive the first drive signal V_{DR-1a} , which may be driven high at a firing time during the positive half cycles of the AC voltage. The first gate drive circuit may start to shape the first target signal $V_{TRGT-1a}$ in response to the first drive signal V_{DR-1a} , and may shape the first target signal $V_{TRGT-1a}$ during a turn-on time period. The first gate drive circuit may use the first target signal $V_{TRGT-1a}$ to render the first semiconductor switch conductive and maintain the first semiconductor switch conductive during the remainder of the positive half cycles. Similarly, a second gate drive circuit of the load control device (*e.g.*, the second gate drive circuit 118) may receive the second drive signal V_{DR-1b} , which may be driven high at a firing time during the negative half cycles of the AC voltage. The second gate drive circuit may shape the second target signal $V_{TRGT-1b}$ in response to the second drive signal V_{DR-1b} , and may shape the second target signal $V_{TRGT-1b}$ during a turn-on time period. The second gate drive circuit may use the second target signal $V_{TRGT-1b}$ to render the second

semiconductor switch conductive and maintain the second semiconductor switch conductive during the remainder of the negative half cycles.

[0072] Further, at the end of the negative half cycles of the AC voltage (*e.g.*, near a zero-crossing of the AC voltage), the first drive signal V_{DR-1a} may be driven low by the control circuit, and the first gate drive circuit may shape the first target signal $V_{TRGT-1a}$ during a turn-off time period. Similarly, at the end of the positive half cycles of the AC voltage (*e.g.*, near a zero-crossing of the AC voltage), the second drive signal V_{DR-1b} may be driven low by the control circuit, and the second gate drive circuit may shape the second target signal $V_{TRGT-1b}$ during a turn-off time period. Accordingly, the first and second target signals $V_{TRGT-1a}$, $V_{TRGT-1b}$ may be shaped on their rising and falling edges. Alternatively, the first and second target signals $V_{TRGT-1a}$, $V_{TRGT-1b}$ may only be shaped on their rising edges and not their falling edges when using the forward phase-control dimming technique.

[0073] FIG. 5 shows examples of waveforms that illustrate an operation of a load control device (*e.g.*, the load control device 100 shown in FIGs. 1 and 2) using a reverse phase-control dimming technique. Similar to the operation of the load control device with a forward phase-control dimming technique described herein, the load control device may receive an AC voltage from an AC power source and may generate a dimmed-hot voltage V_{DH1} at a dimmed-hot terminal of the load control device. Using the reverse phase-control dimming technique and as shown in FIG. 5, a control circuit may render a controllably conductive device conductive at the beginning of each half cycle (*e.g.*, during a conductive period T_{CON}), render the controllably conductive device non-conductive at a firing time (during the half cycle, and maintain the controllably conductive device conductive until the end of the half cycle (*e.g.*, during a non-conductive period T_{NC}). For example, the controllably conductive device may comprise two semiconductor switches, such as in anti-series connection.

[0074] The control circuit may generate a drive signal to control the conductivity of the controllably conductive device. For example, the control circuit may generate a first drive signal V_{DR-1a} to render a first semiconductor switch (*e.g.*, the first FET Q112 of the first controllably conductive device 110) conductive during the positive half cycles. The control circuit may generate a second drive signal V_{DR-1b} to render a second semiconductor switch (*e.g.*, the second FET Q114 of

the second controllably conductive device) conductive during the negative half cycles. As noted above, the first and second drive signals V_{DR-1a} , V_{DR-1b} may be pulse-width modulated signals.

[0075] The load control device may generate target signals (*e.g.*, a first target signal $V_{TRGT-1a}$ and a second target signal $V_{TRGT-1b}$) in response to the control circuit. For example, as described herein, a first gate drive circuit of the load control device (*e.g.*, the first gate drive circuit 116) may receive the first drive signal V_{DR-1a} , which may be high at the beginning of the positive half cycles, such that the controllably conductive device is conductive at the beginning of the positive half cycles. The first drive signal V_{DR-1a} may be driven low at a firing time during the positive half cycles of the AC voltage. The first gate drive circuit may be used to shape the first target signal $V_{TRGT-1a}$ in response to the first drive signal V_{DR-1a} , and may shape the first target signal $V_{TRGT-1a}$ during a turn-off time period. The first gate drive circuit may use the first target signal $V_{TRGT-1a}$ to render the first semiconductor switch non-conductive and maintain the first semiconductor switch non-conductive during the remainder of the positive half cycles. Similarly, a second gate drive circuit of the load control device (*e.g.*, the second gate drive circuit 118) may receive the second drive signal V_{DR-1b} , which may be high at the beginning of the negative half cycles, such that the controllably conductive device is conductive at the beginning of the negative half cycles. The second drive signal V_{DR-1b} may be driven low at a firing time during the negative half cycles of the AC voltage. The load control device may begin to shape the first target signal $V_{TRGT-1a}$ in response to the second drive signal V_{DR-1b} , and may shape the second target signal $V_{TRGT-1b}$ during a turn-off time period. The second gate drive circuit may use the second target signal $V_{TRGT-1b}$ to render the second semiconductor switch non-conductive during the remainder of the negative half cycles.

[0076] Further, at the end of the positive half cycles of the AC voltage (*e.g.*, near a zero-crossing of the AC voltage), the first drive signal V_{DR-1a} may be driven high by the control circuit, and the first gate drive circuit may shape the first target signal $V_{TRGT-1a}$ during a turn-on time period. Similarly, at the end of the negative half cycles of the AC voltage (*e.g.*, near a zero-crossing of the AC voltage), the second drive signal V_{DR-1b} may be driven high by the control circuit, and the second gate drive circuit may shape the second target signal $V_{TRGT-1b}$ during a turn-on time period. Accordingly, the first and second target signals $V_{TRGT-1a}$, $V_{TRGT-1b}$ may be shaped on their rising and falling edges. Alternatively, the first and second target signals $V_{TRGT-1a}$, $V_{TRGT-1b}$ may only be

shaped on their falling edges and not their rising edges when using the reverse phase-control dimming technique.

[0077] FIG. 6 shows examples of waveforms that illustrate an operation of a gate drive circuit (*e.g.*, the gate drive circuit 300) to render a semiconductor switch (*e.g.*, the FET Q330) conductive using a forward phase-control dimming technique. As described herein, a load control device (*e.g.*, the load control device 100 of FIGs. 1 and 2) may receive an AC mains line voltage from an AC power source and may phase control the AC line voltage to generate a dimmed-hot voltage V_{DH} (*e.g.*, a phase-control voltage) at a dimmed-hot terminal of the load control device. The load control device may comprise two gate drive circuits with a first gate drive circuit (*e.g.*, the first gate drive circuit 116 shown in FIG. 1) controlling a first semiconductor switch (*e.g.*, the first FET Q112) in the positive half-cycles (*e.g.*, as shown in FIG. 6) and a second gate drive circuit (*e.g.*, the second gate drive circuit 118 shown in FIG. 1) controlling a second semiconductor switch (*e.g.*, the second FET Q114) in the negative half-cycles. The operation of the second gate drive circuit in the negative half cycles may be the same as the operation of the first gate drive circuit in the positive half cycles as shown in FIG. 6.

[0078] The gate drive circuit of the load control device may receive a drive signal V_{DR} from a control circuit (*e.g.*, the control circuit 115). The control circuit may drive the drive signal V_{DR} high (*e.g.*, towards the DC supply voltage V_{CC}) at a firing time t_{FIRE} . The gate drive circuit may generate a step signal V_{STEP} using a step-up circuit (*e.g.*, the step-up circuit 310). The step-up circuit may receive the drive signal V_{DR} from the control circuit and may drive the magnitude of the step signal V_{STEP} high (*e.g.*, towards the isolated supply voltage V_{SUP}) after a delay period T_{DELAY} from when the drive signal V_{DR} was driven high.

[0079] The gate drive circuit may generate a target signal V_{TRGT} in response to the drive signal V_{DR} from the control circuit. The gate drive circuit may begin to shape the target signal V_{TRGT} in response to the drive signal V_{DR} being driven high and may shape the target signal V_{TRGT} over a turn-on period T_{T-ON} (*e.g.*, approximately 50 μ sec). The gate drive circuit may generate the target signal V_{TRGT} using a turn-on signal V_{T-ON} generated by a turn-on wave-shaping circuit (*e.g.*, the turn-on wave-shaping circuit 312). The gate drive circuit may shape the turn-on signal V_{T-ON} in order to shape the target signal V_{TRGT} . Accordingly, in some examples, the turn-on signal V_{T-ON} may be

defined by an “S” shape over the turn-on period T_{T-ON} . The gate drive circuit may control the magnitude of the turn-on signal V_{T-ON} to a rated current magnitude V_{I-RTD} (e.g., approximately 7.5 volts) at the end of the turn-on period T_{T-ON} . The gate drive circuit may set the target signal V_{TRGT} to be equal to the magnitude of the turn-on signal V_{T-ON} during the turn-on period T_{T-ON} . When the step signal V_{STEP} is driven high after the delay period T_{DELAY} , the gate drive circuit may set the target signal V_{TRGT} to a predetermined level, such as a maximum current magnitude V_{I-MAX} , which may be equal to the magnitude of the step signal V_{STEP} (e.g., approximately 15V). For example, the delay period T_{DELAY} may be approximately equal to the turn-on period T_{T-ON} , such that the target voltage signal V_{TRGT} is set to the magnitude of the step signal V_{STEP} after the turn-on period T_{T-ON} .

[0080] The gate drive circuit may generate a gate control signal V_{GC} based on the target signal V_{TRGT} and a feedback signal V_{I-FB} (not shown) that indicates a magnitude of a load current conducted through the semiconductor switch. The gate drive circuit may adjust a magnitude of the gate control signal V_{GC} in response to the magnitude of the feedback signal V_{I-FB} . For example, the gate drive circuit may adjust the magnitude of the gate control signal V_{GC} in response to a magnitude of the feedback signal V_{I-FB} to adjust a magnitude of the load current I_{LOAD} toward a target current, where for example, the target current is indicated by a magnitude of the target signal V_{TRGT} .

[0081] When the magnitude of the target signal V_{TRGT} is equal to the rated current magnitude V_{I-RTD} at the end of the turn-on period T_{T-ON} , the gate drive circuit may control the magnitude of the gate control signal V_{GC} to attempt to control the magnitude of the load current I_{LOAD} to a maximum rated current I_{RATED} (e.g., approximately 10A). However, the lighting load may not require the maximum rated current I_{RATED} (e.g., the lighting load may be a lower power lighting load), and the magnitude of the gate control signal V_{GC} may deviate from the magnitude of the target signal V_{TRGT} before the magnitude of the gate control signal V_{GC} reaches the rated current magnitude V_{I-RTD} as shown in FIG. 6. When the magnitude of the target signal V_{TRGT} is equal to the maximum current magnitude V_{I-MAX} after the delay period T_{DELAY} , the gate drive circuit may control the magnitude of the gate control signal V_{GC} to attempt to control the magnitude of the load current I_{LOAD} to a maximum current level I_{MAX} (e.g., approximately 20A). However, if the lighting load is not experiencing an overcurrent event (e.g., when the lighting load is shorted) or an inrush current

event (*e.g.*, when conducting an inrush current to the lighting load), the magnitude of the gate control signal V_{GC} may not be driven up to the maximum current magnitude V_{I-MAX} as shown in FIG. 6.

[0082] Since the gate drive circuit is using closed-loop control to adjust the magnitude of the gate control signal V_{GC} based on the feedback signal V_{I-FB} , the magnitude of the gate control signal V_{GC} may indicate (*e.g.*, be proportional to) the present magnitude of the load current I_{LOAD} . As a result, the load current I_{LOAD} may have the same shape as the gate control signal V_{GC} as shown in FIG. 6.

[0083] FIG. 7 shows examples of waveforms that illustrate an operation of a gate drive circuit (*e.g.*, the gate drive circuit 300) to render a semiconductor switch (*e.g.*, the FET Q330) conductive using a forward phase-control dimming technique when the semiconductor switch is experiencing an overcurrent condition (*e.g.*, when a lighting load controlled by the semiconductor switch may be shorted). As described herein, a load control device (*e.g.*, the load control device 100 of FIGs. 1 and 2) may receive an AC line voltage from an AC power source and may phase control the AC line voltage to generate a dimmed-hot voltage V_{DH} (*e.g.*, a phase-control voltage) at a dimmed-hot terminal of the load control device. The load control device may comprise two gate drive circuits with a first gate drive circuit (*e.g.*, the first gate drive circuit 116 shown in FIG. 1) controlling a first semiconductor switch (*e.g.*, the first FET Q112) in the positive half-cycles (*e.g.*, as shown in FIG. 7) and a second gate drive circuit (*e.g.*, the second gate drive circuit 118 shown in FIG. 1) controlling a second semiconductor switch (*e.g.*, the second FET Q114) in the negative half-cycles. The operation of the second gate drive circuit during an overcurrent condition (*e.g.*, a short circuit condition) in the negative half cycles may be the same as the operation of the first gate drive circuit in the positive half cycles as shown in FIG. 7.

[0084] The gate drive circuit of the load control device may receive a drive signal V_{DR} from a control circuit (*e.g.*, the control circuit 115). The control circuit may drive the drive signal V_{DR} high (*e.g.*, towards the DC supply voltage V_{CC}) at a firing time t_{FIRE} . The gate drive circuit may generate a step signal V_{STEP} using a step-up circuit (*e.g.*, the step-up circuit 310). The step-up circuit may receive the drive signal V_{DR} from the control circuit and may drive the magnitude of the step signal V_{STEP} high (*e.g.*, towards the isolated supply voltage V_{SUP}) after a delay period T_{DELAY} from when the drive signal V_{DR} was driven high.

[0085] The gate drive circuit may generate a target signal V_{TRGT} in response to the drive signal V_{DR} from the control circuit. The gate drive circuit may begin to shape the target signal V_{TRGT} in response to the drive signal V_{DR} being driven high and may shape the target signal V_{TRGT} over a turn-on period T_{T-ON} . The gate drive circuit may generate the target signal V_{TRGT} using a turn-on signal V_{T-ON} generated by a turn-on wave-shaping circuit (e.g., the turn-on wave-shaping circuit 213). The gate drive circuit may shape the turn-on signal V_{T-ON} in order to shape the target signal V_{TRGT} . Accordingly, in some examples, the turn-on signal V_{T-ON} may be defined by an “S” shape over the turn-on period T_{T-ON} . The gate drive circuit may control the magnitude of the turn-on signal V_{T-ON} to a rated current magnitude V_{I-RTD} (e.g., approximately 7.5 volts) at the end of the turn-on period T_{T-ON} . The gate drive circuit may set the target signal V_{TRGT} to be equal to the magnitude of the turn-on signal V_{T-ON} during the turn-on period T_{T-ON} . When the step signal V_{STEP} is driven high after the delay period T_{DELAY} , the gate drive circuit may set the target signal V_{TRGT} to a predetermined level, such as a maximum current magnitude V_{I-MAX} , which may be equal to the magnitude of the step signal V_{STEP} (e.g., approximately 15V). For example, the delay period T_{DELAY} may be approximately equal to the turn-on period T_{T-ON} , such that the target voltage signal T_{TRGT} is set to the magnitude of the step signal V_{STEP} after the turn-on period T_{T-ON} .

[0086] The gate drive circuit may generate a gate control signal V_{GC} based on the target signal V_{TRGT} and a feedback signal V_{I-FB} (not shown) that indicates a magnitude of a load current conducted through the semiconductor switch. The gate drive circuit may adjust a magnitude of the gate control signal V_{GC} in response to the magnitude of the feedback signal V_{I-FB} . For example, the gate drive circuit may adjust the magnitude of the gate control signal V_{GC} in response to a magnitude of the feedback signal V_{I-FB} to adjust a magnitude of the load current I_{LOAD} toward a target current, where for example, the target current is indicated by a magnitude of the target signal V_{TRGT} .

[0087] When the magnitude of the target signal V_{TRGT} is equal to the rated current magnitude V_{I-RTD} at the end of the turn-on period T_{T-ON} , the gate drive circuit may control the magnitude of the gate control signal V_{GC} to attempt to control the magnitude of the load current I_{LOAD} to a maximum rated current I_{RATED} (e.g., approximately 10A). During an overcurrent current condition (e.g., when the lighting load has failed shorted), the magnitude of the gate control signal V_{GC} may follow the magnitude of the target signal V_{TRGT} as shown in FIG. 7. When the

magnitude of the target signal V_{TRGT} is driven up to the maximum current magnitude V_{I-MAX} after the delay period T_{DELAY} , the gate drive circuit may control the magnitude of the gate control signal V_{GC} to attempt to control the magnitude of the load current I_{LOAD} to a maximum current level I_{MAX} (e.g., approximately 20A). Because the lighting load may be shorted during the overcurrent condition, the magnitude of the gate control signal V_{GC} may be driven up to the maximum current magnitude V_{I-MAX} as shown in FIG. 7. Since the target signal V_{TRGT} is maintained at the maximum current magnitude V_{I-MAX} , the magnitude of the load current I_{LOAD} may be limited to the maximum current level I_{MAX} during the overcurrent condition.

[0088] Since the gate drive circuit is using closed-loop control to adjust the magnitude of the gate control signal V_{GC} based on the feedback signal V_{I-FB} , the magnitude of the gate control signal V_{GC} may indicate (e.g., be proportional to) the present magnitude of the load current I_{LOAD} . As a result, the load current I_{LOAD} may have the same shape as the gate control signal V_{GC} as shown in FIG. 7. The gate drive circuit may detect an overcurrent condition, using an overcurrent detection circuit (e.g., the overcurrent detection circuit 322). The overcurrent detection circuit may detect the overcurrent condition in response to the gate control signal V_{GC} (e.g., since the magnitude of the gate control signal V_{GC} may indicate present magnitude of the load current I_{LOAD}). For example, the overcurrent detection circuit may detect the overcurrent condition when the magnitude of the gate control signal V_{GC} is equal to the maximum current magnitude V_{I-MAX} .

[0089] During an overcurrent condition, the gate drive circuit may control the magnitude of the target signal V_{TRGT} to turn off the semiconductor switch using an overcurrent protection circuit (e.g., the overcurrent protection circuit 324). The overcurrent protection circuit may control the magnitude of the target signal V_{TRGT} to zero volts to render the semiconductor switch non-conductive after a trip time period T_{TRIP} from when the overcurrent condition was detected (e.g., when the magnitude of the gate control signal V_{GC} is equal to the maximum current magnitude V_{I-MAX} immediately after the turn-on period T_{T-ON} as shown in FIG. 7). For example, the gate drive circuit may maintain the semiconductor switch conductive during the duration of the trip time period T_{TRIP} and render the semiconductor switch non-conductive at the conclusion of the trip time period T_{TRIP} (e.g., if the overcurrent condition is still detected). For instance, at the end of the trip time period T_{TRIP} , the gate drive circuit may decrease (e.g., quickly decrease) the magnitude of the gate

control signal V_{GC} to zero volts (*e.g.*, in response to the overcurrent protection circuit controlling the magnitude of the target signal V_{TRGT} to zero volts), thereby rendering the semiconductor switch non-conductive.

[0090] The overcurrent protection circuit may determine the length of the trip time period T_{TRIP} . In some examples, the length of the trip time period may be fixed or predetermined. In other examples, the length of the trip time period T_{TRIP} may be based on a parameter of the semiconductor switch. For example, the parameter of the semiconductor switch may include a temperature of the semiconductor switch, a power of the semiconductor switch, a voltage developed across the semiconductor switch, and/or the like. The trip time period T_{TRIP} may be inversely proportional to the parameter of the semiconductor switch. For example, the overcurrent protection circuit may be configured to determine the magnitude of the voltage developed across the semiconductor switch in response to a drain voltage signal from a drain voltage sense circuit (*e.g.*, the drain voltage sense circuit). If the magnitude of the voltage developed across the semiconductor switch is high, the trip time period T_{TRIP} may be shorter in comparison to when the voltage developed across the semiconductor switch is low. During an overcurrent condition (*e.g.*, when the lighting load may be shorted), the voltage developed across the semiconductor switch may be high and the trip time period T_{TRIP} may be shorter. By rendering the semiconductor switch non-conductive quicker, the overcurrent current condition may be removed more quickly and the semiconductor switch may be protected during the overcurrent condition.

[0091] FIG. 8 shows examples of waveforms that illustrate an operation of a gate drive circuit (*e.g.*, the gate drive circuit 300) to render a semiconductor switch (*e.g.*, the FET Q330) conductive using a forward phase-control dimming technique when the semiconductor switch is experiencing an inrush current condition (*e.g.*, to charge an input capacitance of a lighting load). As described herein, a load control device (*e.g.*, the load control device 100 of FIGs. 1 and 2) may receive an AC line voltage from an AC power source and may phase control the AC line voltage to generate a dimmed-hot voltage V_{DH} (*e.g.*, a phase-control voltage) at a dimmed-hot terminal of the load control device. The load control device may comprise two gate drive circuits with a first gate drive circuit (*e.g.*, the first gate drive circuit 116 shown in FIG. 1) controlling a first semiconductor switch (*e.g.*, the first FET Q112) in the positive half-cycles (*e.g.*, as shown in FIG. 8) and a second

gate drive circuit (*e.g.*, the second gate drive circuit 118 shown in FIG. 1) controlling a second semiconductor switch (*e.g.*, the second FET Q114) in the negative half-cycles. The operation of the second gate drive circuit during an inrush current condition in the negative half cycles may be the same as the operation of the first gate drive circuit in the positive half cycles as shown in FIG. 8.

[0092] The gate drive circuit of the load control device may receive a drive signal V_{DR} from a control circuit (*e.g.*, the control circuit 115). The control circuit may drive the drive signal V_{DR} high (*e.g.*, towards the DC supply voltage V_{CC}) at a firing time t_{FIRE} . The gate drive circuit may generate a step signal V_{STEP} using a step-up circuit (*e.g.*, the step-up circuit 310). The step-up circuit may receive the drive signal V_{DR} from the control circuit and may drive the magnitude of the step signal V_{STEP} high (*e.g.*, towards the isolated supply voltage V_{SUP}) after a delay period T_{DELAY} from when the drive signal V_{DR} was driven high.

[0093] The gate drive circuit may generate a target signal V_{TRGT} in response to the control circuit. The gate drive circuit may begin to shape the target signal V_{TRGT} in response to the drive signal V_{DR} being driven high and may shape the target signal V_{TRGT} over a turn-on period T_{T-ON} . The gate drive circuit may generate the target signal V_{TRGT} using a turn-on signal V_{T-ON} generated by a turn-on wave-shaping circuit (*e.g.*, the turn-on wave-shaping circuit 213). The gate drive circuit may shape the turn-on signal V_{T-ON} in order to shape the target signal V_{TRGT} . Accordingly, in some examples, the turn-on signal V_{T-ON} may be defined by an “S” shape over the turn-on period T_{T-ON} . The gate drive circuit may control the magnitude of the turn-on signal V_{T-ON} to a rated current magnitude V_{I-RTD} (*e.g.*, approximately 7.5 volts) at the end of the turn-on period T_{T-ON} . The gate drive circuit may set the target signal V_{TRGT} to be equal to the magnitude of the turn-on signal V_{T-ON} during the turn-on period T_{T-ON} . When the step signal V_{STEP} is driven high after the delay period T_{DELAY} , the gate drive circuit may set the target signal V_{TRGT} to a predetermined level, such as a maximum current magnitude V_{I-MAX} , which may be equal to the magnitude of the step signal V_{STEP} (*e.g.*, approximately 15V). For example, the delay period T_{DELAY} may be approximately equal to the turn-on period T_{T-ON} , such that the target voltage signal V_{TRGT} is set to the magnitude of the step signal V_{STEP} after the turn-on period T_{T-ON} .

[0094] The gate drive circuit may generate a gate control signal V_{GC} based on the target signal V_{TRGT} and a feedback signal V_{I-FB} (not shown) that indicates a magnitude of a load current

conducted through the semiconductor switch. The gate drive circuit may adjust a magnitude of the gate control signal V_{GC} in response to the magnitude of the feedback signal V_{I-FB} . For example, the gate drive circuit may adjust the magnitude of the gate control signal V_{GC} in response to a magnitude of the feedback signal V_{I-FB} to adjust a magnitude of the load current I_{LOAD} toward a target current, where for example, the target current is indicated by a magnitude of the target signal V_{TRGT} .

[0095] When the magnitude of the target signal V_{TRGT} is equal to the rated current magnitude V_{I-RTD} at the end of the turn-on period T_{T-ON} , the gate drive circuit may control the magnitude of the gate control signal V_{GC} to attempt to control the magnitude of the load current I_{LOAD} to a maximum rated current I_{RATED} (e.g., approximately 10A). During an inrush current condition (e.g., when the load control device is attempting to charge an input capacitance of the lighting load), the magnitude of the gate control signal V_{GC} may follow the magnitude of the target signal V_{TRGT} as shown in FIG. 8. When the magnitude of the target signal V_{TRGT} is driven up to the maximum current magnitude V_{I-MAX} after the delay period T_{DELAY} , the gate drive circuit may control the magnitude of the gate control signal V_{GC} to attempt to control the magnitude of the load current I_{LOAD} to a maximum current level I_{MAX} (e.g., approximately 20A). Because the lighting load needs to conduct the inrush current during the inrush current event, the magnitude of the gate control signal V_{GC} may be driven up to the maximum current magnitude V_{I-MAX} as shown in FIG. 8. The magnitude of the load current I_{LOAD} may be prevented from exceeding the maximum current level I_{MAX} during the inrush current condition since the target signal V_{TRGT} is maintained at the maximum current magnitude V_{I-MAX} . Since the gate drive circuit is using closed-loop control to adjust the magnitude of the gate control signal V_{GC} based on the feedback signal V_{I-FB} , the magnitude of the gate control signal V_{GC} may indicate (e.g., be proportional to) the present magnitude of the load current I_{LOAD} . As a result, the load current I_{LOAD} may have the same shape as the gate control signal V_{GC} as shown in FIG. 8.

[0096] Since the inrush current condition may cause a large amount of current to be conducted through the semiconductor switch, the inrush current condition may appear as an overcurrent condition (e.g., when the lighting load is shorted as shown in FIG. 7). As described above, the gate drive circuit may detect an overcurrent condition using an overcurrent detection circuit (e.g., the overcurrent detection circuit 322). The overcurrent detection circuit may detect the

overcurrent condition in response to the gate control signal V_{GC} (e.g., since the magnitude of the gate control signal V_{GC} may indicate present magnitude of the load current I_{LOAD}). For example, the overcurrent detection circuit may detect the overcurrent condition when the magnitude of the gate control signal V_{GC} is equal to the maximum current magnitude V_{I-MAX} .

[0097] The overcurrent protection circuit may determine the length of the trip time period T_{TRIP} . In some examples, the length of the trip time period may be fixed or predetermined. In other examples, the length of the trip time period T_{TRIP} may be based on a parameter of the semiconductor switch. For example, the parameter of the semiconductor switch may include a temperature of the semiconductor switch, a power of the semiconductor switch, a voltage developed across the semiconductor switch, and/or the like. The trip time period T_{TRIP} may be inversely proportional to the parameter of the semiconductor switch. For example, the overcurrent protection circuit may be configured to determine the magnitude of the voltage developed across the semiconductor switch in response to a drain voltage signal from a drain voltage sense circuit (e.g., the drain voltage sense circuit). If the magnitude of the voltage developed across the semiconductor switch is high, the trip time period T_{TRIP} may be shorter in comparison to when the voltage developed across the semiconductor switch is low. During an inrush current condition (e.g., when the load control device needs to charge an input capacitance of the lighting load), the voltage developed across the semiconductor switch may be low and the trip time period T_{TRIP} may be long (e.g., longer than the overcurrent condition). As shown in FIG. 8, the magnitude of the load current may decrease away from the maximum current magnitude V_{I-MAX} before the end of the trip time period T_{TRIP} , such that the overcurrent protection circuit may not render the semiconductor switch non-conductive for the remainder of the half cycle.

[0098] FIG. 9 shows examples of waveforms that illustrate an operation of a gate drive circuit (e.g., the gate drive circuit 300) to render a semiconductor switch (e.g., the FET Q330) non-conductive using a reverse phase-control dimming technique. A load control device (e.g., the load control device 100 of FIGs. 1 and 2) may receive an AC mains line voltage from an AC power source and may phase control the AC mains line voltage to generate a dimmed-hot voltage V_{DH} (e.g., a phase-control voltage) at a dimmed-hot terminal of the load control device. The load control device may comprise two gate drive circuits with a first gate drive circuit (e.g., the first gate drive

circuit 116 shown in FIG. 1) controlling a first semiconductor switch (*e.g.*, the first FET Q112) in the positive half-cycles (*e.g.*, as shown in FIG. 9) and a second gate drive circuit (*e.g.*, the second gate drive circuit 118 shown in FIG. 1) controlling a second semiconductor switch (*e.g.*, the second FET Q114) in the negative half-cycles. The operation of the second gate drive circuit in the negative half cycles may be the same as the operation of the first gate drive circuit in the positive half cycles as shown in FIG. 9. Further, it should be appreciated that the slope of the dimmed-hot voltage V_{DHI} when transitioning to zero as shown in FIG. 9 is exaggerated to illustrate the changes and correlations between the other signals shown in FIG. 9, such as the drain voltage sense signal V_{DV} , the turn-off Signal V_{T-OFF} , the target signal V_{TRGT} , the gate control signal V_{GC} , and/or the load current I_{LOAD} .

[0099] The gate drive circuit of the load control device may receive a drive signal V_{DR} from a control circuit (*e.g.*, the control circuit 115). The control circuit may drive the drive signal V_{DR} high (*e.g.*, towards the DC supply voltage V_{CC}) at the beginning of a half-cycle of the AC mains line voltage. The gate drive circuit may generate a target signal V_{TRGT} in response to the drive signal V_{DR} from the control circuit. The control circuit may drive the drive signal V_{DR} low at a firing time t_{FIRE} . Prior to the firing time t_{FIRE} , a magnitude of the target signal V_{TRGT} may be equal to a maximum current magnitude V_{I-MAX} (*e.g.*, approximately 15V). In response to the control circuit driving the magnitude of the drive signal V_{DR} low at the firing time t_{FIRE} , the gate drive circuit may decrease the magnitude of the target signal V_{TRGT} to a predetermined value, such as a rated current magnitude V_{I-RTD} , which may be approximately 50% of the maximum current magnitude V_{I-MAX} (*e.g.*, from approximately 15V to 7.5V).

[0100] After decreasing the magnitude of the target voltage V_{TRGT} from the maximum current magnitude V_{I-MAX} to the rated current magnitude V_{I-RTD} , the gate drive circuit may decrease (*e.g.*, gradually decrease with respect to time) the magnitude of the target signal V_{TRGT} while monitoring a characteristic of (*e.g.*, a voltage developed across) the semiconductor switch. For example, the gate drive circuit may receive a drain voltage sense signal V_{DV} from a drain voltage sense circuit (*e.g.*, the drain voltage sense circuit 328), where the drain voltage sense signal V_{DV} indicates a magnitude of the voltage across the semiconductor switch. When semiconductor switch is conductive, the magnitude of the voltage across the semiconductor switch is substantially small

(*e.g.*, approximately zero volts). When the magnitude of the target voltage V_{TRGT} decreases to a point that the semiconductor switch begins to become non-conductive, the magnitude of the voltage across the semiconductor switch may begin to increase causing the magnitude of the drain voltage sense signal V_{DV} to increase as shown in FIG. 9. The gate current sense circuit may determine when the magnitude of the drain voltage sense signal V_{DV} exceeds a drain voltage threshold V_{TH} (*e.g.*, approximately 1V).

[0101] When the gate drive circuit detects that the voltage developed across the semiconductor switch has started to increase in magnitude such that the magnitude of the drain voltage sense signal V_{DV} exceeds the drain voltage threshold V_{TH} , the gate drive circuit may begin to shape the target signal V_{TRGT} from a present value towards zero volts, for example, as shown in FIG. 9. The gate drive circuit may shape the target signal V_{TRGT} over a turn-off period T_{T-OFF} (*e.g.*, approximately 40 μ sec). The gate drive circuit may generate the target signal V_{TRGT} using a turn off signal V_{T-OFF} generated by a turn-off wave-shaping circuit (*e.g.*, the turn-off wave-shaping circuit 314). Accordingly, the gate drive circuit may use the drain voltage sense signal V_{DV} as a trigger for the gate drive circuit to begin wave-shaping the turn-off signal V_{T-OFF} (*e.g.*, and also the target signal V_{TRGT}). Alternatively, the gate drive circuit may wave-shape the target signal V_{TRGT} irrespective of the magnitude of the drain voltage sense signal V_{DV} . For example, the gate drive circuit may shape the target signal V_{TRGT} after (*e.g.*, immediately after) the magnitude of the target signal V_{TRGT} is decreased from the maximum current magnitude V_{I-MAX} to the rated current magnitude V_{I-RTD} . The gate drive circuit may shape the turn-off signal V_{T-OFF} (*e.g.*, and also the target signal V_{TRGT}) in a preconfigured shape, such as a S-shape, based on the magnitude of the drain voltage sense signal V_{DV} . The gate drive circuit may shape the turn-off signal V_{T-OFF} in a first shape during a first portion of the turn-off period T_{T-OFF} , and shape the turn-off signal V_{T-OFF} in a second shape during a second portion of the turn-off period T_{T-OFF} (*e.g.*, to create the S-shape).

[0102] The gate drive circuit may generate a gate control signal V_{GC} based on the target signal V_{TRGT} and a feedback signal V_{I-FB} (not shown) that indicates a magnitude of a load current conducted through an electrical load as described herein. As described herein, the gate drive circuit may adjust a magnitude of the gate control signal V_{GC} in response to a magnitude of the feedback signal V_{I-FB} . For example, as shown in FIG. 9, the gate drive circuit may adjust the magnitude of the

gate control signal V_{GC} in response to the magnitude of the feedback signal V_{I-FB} , and thereby, adjust a magnitude of the load current I_{LOAD} toward a target current. The gate drive circuit may render the semiconductor switch non-conductive by adjusting the magnitude of the gate control signal V_{GC} to zero volts, and thereby, controlling the magnitude of the load current through the electrical load to zero amps. Since the gate drive circuit is using closed-loop control to adjust the magnitude of the gate control signal V_{GC} based on the feedback signal V_{I-FB} , the magnitude of the gate control signal V_{GC} may indicate (*e.g.*, be proportional to) the present magnitude of the load current I_{LOAD} . As a result, the load current I_{LOAD} may have the same shape as the gate control signal V_{GC} as shown in FIG. 9.

[0103] FIG. 10 is a flowchart of an example control procedure 1000 that may be executed by a load control device. For example, the control procedure 1000 may be performed by the load control device 100 (*e.g.*, a dimmer switch) for controlling the amount of power delivered from an AC power source to one or more electrical loads, such as lighting loads 102, 103. The control procedure 1000 may be performed by any combination of a control circuit (*e.g.*, the control circuit 115 and/or a control circuit that is part of and/or dedicated to a gate drive circuit, such as the gate drive circuit 116, 118, 126, 128, and/or 300) and/or analog circuitry (*e.g.*, a gate drive circuit, such as the gate drive circuit 116, 118, 126, 128, and/or 300). For instance, in some examples, the load control device may include multiple control circuits, such as a control circuit that is dedicated to a gate drive circuit. In such examples, the control procedure 1000 may be performed by one or any combination of a general control circuit (*e.g.*, the control circuit 115), a gate drive control circuit, and/or analog circuitry of the load control device. The load control device may execute the control procedure periodically, such as within each half-cycle of an AC mains line voltage received from the AC power source. Further, although illustrated as including 1002-1012, a load control device may perform any combination of 1002-1012 when performing the control procedure 1000 (*e.g.*, any combination of 1002-1012 may be omitted).

[0104] When executing the control procedure 1000, the load control device may be operating using a forward-phase control technique. When operating using a forward phase control technique, the load control device may render (*e.g.*, begin to render) the semiconductor switch conductive at a firing time t_{FIRE} (*e.g.*, at a firing angle) relative to the zero-crossing points of the AC mains line

voltage V_{AC} (e.g., as determined from the zero-cross signal) to generate a phase-control dimmed-hot voltage V_{PC} . The load control device may be configured to determine and/or adjust the firing time t_{FIRE} (e.g., a phase angle) of a semiconductor switch (e.g., of a controllably conductive device) each half cycle to control the amount of power delivered to the electrical, for example, to control the intensity of a lighting load toward a target intensity.

[0105] At 1002, the load control device may determine whether the time during a present half-cycle of AC mains line voltage is at a firing time t_{FIRE} relative to the zero-crossing points. If the time during the present half-cycle of AC mains line voltage is not at the firing time t_{FIRE} , then the load control device may wait. Once the load control device determines that the time during the present half-cycle of AC mains line voltage is at the firing time t_{FIRE} at 1002, the load control device may adjust (e.g., generate) a target value (e.g., a value of the target signal V_{TRGT}) over a period of time (e.g., a turn-on period T_{T-ON}) at 1004. For example, the load control device may adjust (e.g., shape) the target value over the period of time (e.g., a turn-on period T_{T-ON}) by adjusting a magnitude of the target value with respect to time over the period of time using, for example, preconfigured shape, such as an S-shape. When the load control device generates the target value, this may cause the load control device to render the semiconductor switch conductive at the firing time during a half-cycle of the AC power source using the forward phase control technique. For example, the load control device may generate a gate control signal for controlling an impedance of the semiconductor switch when the semiconductor switch is conductive. The load control device may also receive a first feedback signal (e.g., the feedback signal V_{I-FB}) that is indicative of a magnitude of the load current conducted through the semiconductor switch, and may adjust a magnitude of the gate control signal in response to the first feedback signal to control the magnitude of the load current towards the target value (e.g., determined by the target signal V_{TRGT}).

[0106] At 1006, the load control device may determine whether the turn-on period T_{T-ON} is over. If it is not at the end of the turn-on period T_{T-ON} , the load control device may continue to determine or adjust the target value at 1004. If the load control device determines that the turn-on period T_{T-ON} is over at 1006, the load control device may set the target value equal to a predetermined level at 1008. The predetermined level may be a maximum current value (e.g., the maximum current magnitude V_{I-MAX}). At 1010, the load control device may determine a trip time

period T_{TRIP} . In some examples, the length of the trip time period may be fixed or predetermined. In other examples, the length of the trip time period T_{TRIP} may be based on a parameter of the semiconductor switch. For example, the length of the trip time period may be based on any combination of a temperature of the semiconductor switch, a power of the semiconductor switch, a voltage developed across the semiconductor switch, and/or the like. For example, the load control device may receive a second feedback signal that may indicate the characteristic of the semiconductor switch, such as a magnitude of the voltage developed across the semiconductor switch (*e.g.*, the drain voltage sense signal V_{DV}). The trip time period T_{TRIP} may be inversely proportional to the parameter of the semiconductor switch.

[0107] At 1012, the load control device may determine whether the trip time period T_{TRIP} is over. If the trip time period T_{TRIP} is not over at 1012, the load control device may wait. If the trip time period T_{TRIP} is over at 1012, the load control device may determine whether the magnitude of the gate control signal V_{GC} is equal to the predetermined level (*e.g.*, equal to the maximum current value or the maximum current magnitude V_{I-MAX}), or otherwise stated, is equal to the target value, at 1014. If the load control device determines that the magnitude of the gate control signal V_{GC} is not equal to the predetermined level at the end of the trip time period T_{TRIP} at 1014, the control procedure 1000 may exit (*e.g.*, such that the load control device may continue to generate the gate control signal to control the impedance of the semiconductor switch in response to the target value and the first feedback signal). For example, the magnitude of the gate control signal V_{GC} may deviate from the magnitude of the predetermined level or target value (*e.g.*, as shown in FIG. 6). For example, the magnitude of the gate control signal V_{GC} may not be driven up to the maximum current magnitude V_{I-MAX} as shown in FIG. 6.

[0108] If the load control device determines that the gate control signal V_{GC} is equal to the predetermined level at the end of the trip time period T_{TRIP} at 1014, the load control device may detect an overcurrent condition at 1016. In response to detecting an overcurrent condition, the load control device may perform any combination of actions. For example, the load control device may decrease the magnitude of the gate control signal V_{GC} to zero volts, render the semiconductor switch non-conductive, alter a user of the overcurrent condition, *etc.* For example, the load control device may control the magnitude of the target value or the gate control signal V_{GC} to turn off the

semiconductor switch directly or using an overcurrent protection circuit (*e.g.*, the overcurrent protection circuit 324). Accordingly, the load control device may maintain the semiconductor switch conductive during the duration of the trip time period T_{TRIP} and render the semiconductor switch non-conductive at the conclusion of the trip time period T_{TRIP} if an overcurrent condition is detected. For instance, in response to detecting an overcurrent condition and at the end of the trip time period T_{TRIP} , the load control device may decrease (*e.g.*, quickly decrease) the magnitude of the gate control signal V_{GC} to zero volts (*e.g.*, in response to controlling the magnitude of the target signal V_{TRGT} to zero volts), thereby rendering the semiconductor switch non-conductive.

[0109] FIG. 11 is a flowchart of an example control procedure 1100 that may be executed by a load control device. For example, the control procedure 1100 may be performed by the load control device 100 (*e.g.*, a dimmer switch) for controlling the amount of power delivered from an AC power source to one or more electrical loads, such as lighting loads 102, 103. The control procedure 1100 may be performed by any combination of a control circuit (*e.g.*, the control circuit 115 and/or a control circuit that is part of and/or dedicated to a gate drive circuit, such as the gate drive circuit 116, 118, 126, 128, and/or 300) and/or analog circuitry (*e.g.*, a gate drive circuit, such as the gate drive circuit 116, 118, 126, 128, and/or 300). For instance, in some examples, the load control device may include multiple control circuits, such as a control circuit that is dedicated to a gate drive circuit. In such examples, the control procedure 1100 may be performed by one or any combination of a general control circuit (*e.g.*, the control circuit 115), a gate drive control circuit, and/or analog circuitry of the load control device. The load control device may execute the control procedure periodically, such as within each half-cycle of an AC mains line voltage received from the AC power source. Further, although illustrated as including 1102-1112, a load control device may perform any combination of 1102-1112 when performing the control procedure 1100 (*e.g.*, any combination of 1102-1112 may be omitted).

[0110] When executing the control procedure 1100, the load control device may be operating using a reverse-phase control technique. When using a reverse phase-control dimming technique, the load control device may render a semiconductor switch conductive (*e.g.*, to cause the controllably conductive device to be conductive) at the beginning of each half cycle of the AC mains line voltage, and then render (*e.g.*, begin to render) the semiconductor switch non-conductive (*e.g.*,

to cause the controllably conductive devices 110, 120 to be non-conductive) at a firing time t_{FIRE} (e.g., at a firing angle) during the half cycle after which the controllably conductive device may remain non-conductive until the end of the half cycle. The load control device may be configured to determine and/or adjust the firing time t_{FIRE} (e.g., a phase angle) of a semiconductor switch (e.g., of a controllably conductive device) each half cycle to control the amount of power delivered to the electrical, for example, to control the intensity of a lighting load toward a target intensity.

[0111] At 1102, the load control device may set a target value (e.g., a value of the target signal V_{TRGT}) equal to a first predetermined level (e.g., a maximum current magnitude $V_{\text{I-MAX}}$), which for example, may begin at the beginning of each half cycle of the AC mains line voltage. In some examples, the maximum current magnitude $V_{\text{I-MAX}}$ may be approximately 15 volts. The load control device may generate a gate control signal V_{GC} for controlling an impedance of the semiconductor switch when the semiconductor switch is conductive, for example, in response to the target value being set (e.g., to the first predetermined level). For example, the load control device may receive a first feedback signal (e.g., the feedback signal $V_{\text{I-FB}}$) that is indicative of a magnitude of the load current conducted through the semiconductor switch, and may adjust a magnitude of the gate control signal V_{GC} in response to the first feedback signal to control the magnitude of the load current towards a target value (e.g., determined from the values of the target signal V_{TRGT}). At 1104, the load control device may determine whether the time during a present half-cycle of AC mains line voltage is at a firing time t_{FIRE} . If the time during the present half-cycle of AC mains line voltage is not at the firing time t_{FIRE} , at 1104, the load control device may wait.

[0112] If the time during the present half-cycle of AC mains line voltage is at the firing time t_{FIRE} at 1104, the load control device may set the target value to a second predetermined value (e.g., a rated current magnitude $V_{\text{I-RTD}}$) at the firing time t_{FIRE} at 1106. In some examples, the rated current magnitude $V_{\text{I-RTD}}$ may be approximately 7.5 volts. Further, in some examples, the load control device may not set the target value to the second predetermined value at 1106, and 1106 may be omitted from the control procedure 1100. At 1108, the load control device may decrease the target value. For example, the load control device may decrease (e.g., linearly decrease) the target value with respect to time from the second predetermined value to an intermediate value, for example while a second feedback signal is above or below a threshold. The second feedback signal may

indicate a characteristic of the semiconductor switch, such as a magnitude of a voltage developed across the semiconductor switch (*e.g.*, the drain voltage sense signal V_{DV}).

[0113] At 1110, the load control device may determine whether the characteristics of the semiconductor switch is greater than a threshold (*e.g.*, the drain voltage threshold V_{TH}). If the load control device determines that the characteristics of the semiconductor switch is less than the threshold at 1110, the load control device may wait. If the load control device determines that the characteristics of the semiconductor switch is greater than the threshold at 1110, the load control device may change the target value from a present value to zero over a turn-off period T_{T-OFF} at 1112. The present value may be the value of the target value when the second feedback signal exceeds the threshold. For example, the load control device may shape the target value with respect to time (*e.g.*, in accordance with an S-shape) during the turn-off period from the present value (*e.g.*, intermediate value) to zero in response to the second feedback signal exceeding the threshold.

[0114] The load control device may generate the gate control signal V_{GC} based on the target value and the second feedback signal, for example, during the turn-off period. As the load control device changes the target value from the present value to zero at 1112, the load control device may control the impedance of the semiconductor switch until the semiconductor switch is rendered non-conductive (*e.g.*, when the target value is zero and the gate control signal V_{GC} is zero volts), which thereby, controls the magnitude of the load current through the electrical load to zero amps. Since the load control device is using closed-loop control to adjust the magnitude of the gate control signal V_{GC} based on the first feedback signal, the magnitude of the gate control signal V_{GC} may indicate (*e.g.*, be proportional to) the present magnitude of the load current I_{LOAD} . Finally, the control procedure 1100 may be used to accommodate lower load currents due to load ratings and/or dimming angles. The control procedure 1100 may provide a smooth transition from an on-state to a gradual off-state, which may improves the EMC performance of the load control device.

CLAIMS

What is claimed:

1. A load control device configured to control power delivered from an AC power source to an electrical load, the load control device comprising:
 - a controllably conductive device adapted to be coupled in series between the AC power source and the electrical load, the controllably conductive device comprising a semiconductor switch configured to conduct a load current through the electrical load;
 - a control circuit; and
 - a gate drive circuit configured to:
 - generate a target signal in response to the control circuit,
 - receive a feedback signal indicative of a magnitude of the load current conducted through the semiconductor switch, and
 - generate a gate control signal in response to the target signal and the feedback signal;
 - wherein the semiconductor switch of the controllably conductive device configured to be rendered conductive and non-conductive in response to the gate control signal.
2. The load control device of claim 1, wherein the gate drive circuit is configured to shape the target signal over a period of time by adjusting a magnitude of the target signal with respect to time over the period of time.
3. The load control device of claim 1, wherein the gate drive circuit is configured to adjust a magnitude of the gate control signal in response to a magnitude of the feedback signal to adjust the magnitude of the load current towards a target current indicated by a magnitude of the target signal.
4. The load control device of claim 3, further comprising:
 - a sense resistor coupled between the semiconductor switch and a circuit common, and configured to conduct the load current:

wherein the feedback signal is generated across the sense resistor and is referenced to circuit common.

5. The load control device of claim 4, wherein the gate drive circuit comprises an operational amplifier circuit configured to receive the target signal and feedback signal, and generate the gate control signal to adjust the magnitude of the load current towards the target current indicated by the magnitude of the target signal, the operational amplifier circuit referenced to circuit common.

6. The load control device of claim 1, wherein the control circuit is configured to generate a drive signal, and the gate drive circuit is configured to begin to shape the target signal in response to the drive signal.

7. A load control device configured to control power delivered from an AC power source to an electrical load, the load control device comprising:

a controllably conductive device adapted to be coupled in series between the AC power source and the electrical load, the controllably conductive device comprising a semiconductor switch configured to conduct a load current through the electrical load;

a control circuit; and

a gate drive circuit configured to:

generate a target signal in response to the control circuit;

receive a first feedback signal indicative of a magnitude of the load current conducted through the semiconductor switch;

receive a second feedback signal indicative of a magnitude of a voltage developed across the semiconductor switch,

shape the target signal during a turn-off period in response to the second feedback signal, and

generate a gate control signal in response to the target signal and the first feedback signal;

wherein the semiconductor switch of the controllably conductive device configured to be rendered non-conductive in response to the gate control signal.

8. The load control device of claim 7, wherein the gate drive circuit is configured to adjust a magnitude of the gate control signal in response to a magnitude of the first feedback signal to adjust the magnitude of the load current towards a target current indicated by a magnitude of the target signal.

9. The load control device of claim 8, wherein the control circuit is configured to generate a drive signal, and the gate drive circuit is configured to begin to decrease the magnitude of the target signal with respect to time in response to the drive signal.

10. The load control device of claim 9, wherein the gate drive circuit is configured to begin to shape the target signal in response to the second feedback signal.

11. The load control device of claim 10, wherein the gate drive circuit is configured to begin to decrease the shape the target signal when the magnitude of the second feedback signal exceeds a threshold.

12. The load control device of claim 10, wherein the gate drive circuit is configured to shape the gate control signal by decreasing the magnitude of the gate control signal with respect to time over a period of time.

13. A load control device configured to control power delivered from an AC power source to an electrical load, the load control device comprising:

a controllably conductive device adapted to be coupled in series between the AC power source and the electrical load, the controllably conductive device comprising a semiconductor switch configured to conduct a load current through the electrical load;

a control circuit; and

a gate drive circuit configured to:

generate a target signal in response to the control circuit,

shape the target signal over a period of time,
increase the target signal to a predetermined level after the period of time,
receive a feedback signal indicative of a magnitude of the load current conducted through the semiconductor switch, and
generate a gate control signal in response to the target signal and the feedback signal;
wherein the semiconductor switch of the controllably conductive device configured to be rendered conductive and non-conductive in response to the gate control signal.

14. The load control device of claim 13, wherein the gate drive circuit is configured to adjust a magnitude of the gate control signal in response to a magnitude of the feedback signal to adjust the magnitude of the load current towards a target current indicated by a magnitude of the target signal.

15. The load control device of claim 14, wherein, when the magnitude of the target signal is at the predetermined level, the gate drive circuit is configured to limit the magnitude of the load current to a maximum current level set by the predetermined level.

16. The load control device of claim 15, wherein the gate drive circuit is configured to detect an overcurrent condition in the semiconductor switch when the magnitude of the gate control signal is equal to the predetermined level.

17. The load control device of claim 16, wherein the gate drive circuit is configured to render the semiconductor switch non-conductive when the magnitude of the gate control signal is equal to the predetermined level for the length of a trip time period after the overcurrent condition is detected.

18. A load control device configured to control power delivered from an AC power source to an electrical load, the load control device comprising:
a controllably conductive device adapted to be coupled in series between the AC power

source and the electrical load, the controllably conductive device comprising a semiconductor switch configured to conduct a load current through the electrical load;

a control circuit; and

a gate drive circuit configured to:

limit a magnitude of the load current to a maximum current level when the semiconductor switch is conductive,

detect an overcurrent condition when the magnitude of the load current is at the maximum current level,

determine a trip time period based on a parameter of the semiconductor switch, and

render the semiconductor switch non-conductive when the magnitude of the load current is at the maximum current level for the trip time period after the overcurrent condition is detected.

19. The load control device of claim 18, wherein the gate drive circuit is configured to generate a gate control signal for rendering the semiconductor switch conductive and non-conductive.

20. The load control device of claim 19, wherein the gate drive circuit is configured to: generate a target signal in response to the control circuit, shape the target signal over a period of time, receive a feedback signal indicative of the magnitude of the load current conducted through the semiconductor switch, and generate the gate control signal in response to the target signal and the feedback signal.

21. The load control device of claim 20, wherein the gate drive circuit is configured to adjust a magnitude of the gate control signal in response to a magnitude of the feedback signal to adjust the magnitude of the load current towards a target current indicated by a magnitude of the target signal.

22. The load control device of claim 18, wherein the parameter of the semiconductor switch comprises one or more of a temperature across the semiconductor switch, a power of the semiconductor switch, or a voltage developed across the semiconductor switch.

23. The load control device of claim 18, wherein the length of the trip time period is inversely proportional to a value of the parameter of the semiconductor switch.

24. The load control device of claim 18, wherein the gate control circuit is configured to render the semiconductor switch non-conductive by controlling the magnitude of the target signal to zero volts.

25. A load control device configured to control power delivered from an AC power source to an electrical load, the load control device comprising:
a controllably conductive device adapted to be coupled in series between the AC power source and the electrical load, the controllably conductive device comprising a semiconductor switch configured to conduct a load current through the electrical load;
a control circuit;
a gate drive circuit configured to:
generate a target signal in response to the control circuit,
shape the target signal over a period of time,
receive a feedback signal indicative of a magnitude of the load current conducted through the semiconductor switch,
generate a gate control signal in response to the target signal and the feedback signal,
and
detect an overcurrent condition in the semiconductor switch in response to the gate control signal.

26. The load control device of claim 18, wherein the gate drive circuit is configured to increase the target signal to a predetermined level after the period of time, and detect the overcurrent

condition in the semiconductor switch when the magnitude of the gate control signal is equal to the predetermined level.

27. The load control device of claim 26, wherein the gate drive circuit is configured to render the semiconductor switch non-conductive when the magnitude of the gate control signal is equal to the predetermined level for the length of a trip time period after the overcurrent condition is detected.

28. The load control device of claim 27, wherein the trip time period is based on a parameter of the semiconductor switch.

29. The load control device of claim 28, wherein the parameter of the semiconductor switch comprises one or more of a temperature across the semiconductor switch, a power of the semiconductor switch, or a voltage developed across the semiconductor switch.

30. The load control device of claim 28, wherein the length of the trip time period is inversely proportional to a value of the parameter of the semiconductor switch.

31. The load control device of claim 18, wherein the gate drive circuit is configured to adjust a magnitude of the gate control signal in response to a magnitude of the feedback signal to adjust the magnitude of the load current towards a target current indicated by a magnitude of the target signal.

32. A load control device configured to control power delivered from an AC power source to an electrical load, the load control device comprising:

a first load control circuit comprising a first controllably conductive device having at least one semiconductor switch adapted to be coupled between the AC power source and the electrical load, the first load control circuit further comprising a first closed-loop gate drive circuit configured to control a magnitude of a gate voltage provided to a gate of the at least one semiconductor switch of the first controllably conductive device in response to a magnitude of a first load current

conducted through the at least one semiconductor switch and to limit the magnitude of the first load current to a maximum current level;

a second load control circuit comprising a second controllably conductive device having at least one semiconductor switch adapted to be coupled between the AC power source and the electrical load, the second load control circuit further comprising a second closed-loop gate drive circuit configured to control a magnitude of a gate voltage provided to a gate of the at least one semiconductor switch of the second controllably conductive device in response to a magnitude of a second load current conducted through the at least one semiconductor switch and to limit the magnitude of the second load current to the maximum current level; and

a control circuit configured to generate first and second drive signals that are received by the respective first and second closed-loop gate drive circuits for controlling the respective first and second controllably conductive devices, the control circuit configured to control the first and second drive signals to be synchronized to the AC power source and to have the same duty cycle;

wherein the first closed-loop gate circuit is configured to limit the magnitude of the first load current in the at least one semiconductor switch of the first controllably conductive device to the maximum current level when the at least one semiconductor switch of the second controllably conductive device becomes conductive in response to the second drive signal before the at least one semiconductor switch of the first controllably conductive device becomes conductive in response to the first drive signal; and

wherein the second closed-loop gate circuit is configured to limit the magnitude of the second load current in the at least one semiconductor switch of the second controllably conductive device to the maximum current level when the at least one semiconductor switch of the first controllably conductive device becomes conductive in response to the first drive signal before the at least one semiconductor switch of the second controllably conductive device becomes conductive in response to the second drive signal.

33. A load control device configured to control power delivered from an AC power source to an electrical load, the load control device comprising:

- a hot terminal adapted to be electrically coupled to a hot side of the AC power source;
- a dimmed-hot terminal adapted to be electrically coupled to the electrical load;

a neutral terminal;
a controllable conductive device coupled in series with the electrical load, the controllable conductive device comprising a first semiconductor switch and a second semiconductor switch;
a control circuit; and
a first closed-loop gate drive circuit configured to:
 receive a first drive signal from the control circuit, and
 generate a first gate control signal in response to the first drive signal and a drain-source current through the first semiconductor switch.

34. The load control device of claim 33, wherein the first closed-loop gate drive circuit is configured to detect the drain-source current through the first semiconductor switch based on a first feedback signal generated across a sense resistor associated with the first semiconductor switch.

35. The load control device of claim 33, wherein the first closed-loop gate drive circuit is configured to:
 shape the first drive signal during a turn-on period to generate a first target signal;
 shape the first drive signal during a turn-off period to generate the first target signal; and
 generate the first gate control signal in response to the first target signal and the drain-source current through the first semiconductor switch.

36. The load control device of claim 33, wherein the first closed-loop gate drive circuit comprises an overcurrent protection circuit configured to turn off the first semiconductor switch during an overcurrent condition.

37. The load control device of claim 33, wherein the first closed-loop gate drive circuit comprises an overcurrent protection circuit and a first voltage amplifier circuit, the overcurrent protection circuit configured to control an input of the first voltage amplifier circuit based on detecting an overcurrent condition.

38. The load control device of claim 33, wherein the first closed-loop gate drive circuit comprises an overcurrent protection circuit, the overcurrent protection circuit configured to determine a trip time period for the first semiconductor switch based on a parameter associated with the first semiconductor switch; and

wherein the first closed-loop gate drive circuit is configured to adjust the first gate control signal based on the trip time period.

39. The load control device of claim 38, wherein the parameter associated with the first semiconductor switch comprises one or more of a temperature across the first semiconductor switch, a power of the first semiconductor switch, or a drain voltage developed across the first semiconductor switch.

40. The load control device of claim 38, wherein the trip time period is associated with a safe operating area of the first semiconductor switch.

41. The load control device of claim 38, wherein the overcurrent protection circuit is configured to determine the parameter associated with the first semiconductor switch based on detecting a drain voltage developed across the first semiconductor switch via a drain voltage sense circuit coupled in series with the first semiconductor switch.

42. The load control device of claim 33, wherein the first closed-loop gate drive circuit comprises:

a turn-on wave-shaping circuit configured to shape the first drive signal to generate a first target signal with a first shape during a first portion of a turn-on period and shape the first target signal with a second shape during a second portion of the turn-on period; and

a turn-off wave-shaping circuit configured to shape the first drive signal to generate the first target signal with a first shape during a first portion of a turn-off period and shape the first target signal with a second shape during a second portion of the turn-off period; and

wherein the first closed-loop gate drive circuit is configured to generate the first gate control signal in response to the first target signal and the drain-source current across the first semiconductor switch.

43. The load control device of claim 42, wherein the first closed-loop gate drive circuit comprises:

a first target signal set circuit configured to:

receive a turn-on signal from the turn-on wave-shaping circuit and receive a turn-off signal from the turn-off wave-shaping circuit,

receive a step signal from a first step-up circuit a predetermined time after receiving the first drive signal from the control circuit, and

generate the first target signal based on one or more of the turn-on signal, the turn-off signal, and the step signal; and

wherein the first closed-loop gate drive circuit is configured to generate the first gate control signal in response to the first target signal and the drain-source current across the first semiconductor switch.

44. The load control device of claim 33, wherein the control circuit is configured to render the first semiconductor switch conductive during a positive half cycle of an AC mains line voltage received from the AC power source, the second semiconductor switch conductive during a negative half cycle of the AC mains line voltage received from the AC power source.

45. A load control device configured to control power delivered from an AC power source to an electrical load, the load control device comprising:

a hot terminal adapted to be electrically coupled to a hot side of the AC power source;

a dimmed-hot terminal adapted to be electrically coupled to the electrical load;

a neutral terminal;

a controllable conductive device coupled in series with the electrical load, the controllable conductive device comprising a first semiconductor switch and a second semiconductor switch;

a control circuit; and

a first closed-loop gate drive circuit comprising a drain voltage sense circuit coupled in series with the first semiconductor switch, the drain voltage sense circuit configured to detect a drain-source voltage of the first semiconductor switch, and generate a drain voltage sense signal in response to detecting the drain-source voltage across the first semiconductor switch;

wherein the first closed-loop gate drive circuit is configured to:

receive a first drive signal from the control circuit,

receive the drain voltage sense signal, and

generate, during a turn-off period, a first gate control signal in response to the first drive signal and the drain voltage sense signal.

46. The load control device of claim 45, wherein the first closed-loop gate drive circuit is configured to:

shape a first target signal during the turn-off period; and

generate, during the turn-off period, the first gate control signal in response to the shaped first target signal and the drain voltage sense signal.

47. The load control device of claim 45, wherein the first closed-loop gate drive circuit is configured to:

shape a first target signal in response to receiving the drain voltage sense signal from the drain voltage sense circuit during the turn-off period; and

generate, during the turn-off period, the first gate control signal in response to the shaped first target signal and the drain voltage sense signal.

48. The load control device of claim 47, wherein the drain voltage sense signal indicates the drain-source voltage developed across the first semiconductor switch; and

wherein the first closed-loop gate drive circuit is configured to shape the first target signal irrespective of the drain-source voltage developed across the first semiconductor switch.

49. The load control device of claim 45, wherein the first closed-loop gate drive circuit is configured to shape a first target signal with a first shape during a first portion of a turn-off period

and shape the first target signal with a second shape during a second portion of the turn-off period to generate a shaped first target signal that has a preconfigured shape; and

generate, during the turn-off period, the first gate control signal in response to the shaped first target signal and the drain voltage sense signal.

50. The load control device of claim 49, wherein the preconfigured shape is an S-shape.

51. A load control device configured to control power delivered from an AC power source to an electrical load, the load control device comprising:

a hot terminal adapted to be electrically coupled to a hot side of the AC power source;

a dimmed-hot terminal adapted to be electrically coupled to the electrical load;

a neutral terminal;

a controllable conductive device coupled in series with the electrical load, the controllable conductive device comprising a first semiconductor switch and a second semiconductor switch;

a control circuit; and

a first closed-loop gate drive circuit configured to generate a first gate control signal in response to receiving a first drive signal and a first feedback signal that is indicative of a drain-source current through the first semiconductor switch,

wherein the first closed-loop gate drive circuit comprises an overcurrent protection circuit that is configured to control the first gate control signal in response to detecting an overcurrent condition.

52. The load control device of claim 51, wherein the first closed-loop gate drive circuit is configured to:

shape the first drive signal during a turn-on period to generate a first target signal; and

generate the first gate control signal in response to the first target signal and the drain-source current through the first semiconductor switch.

53. The load control device of claim 52, wherein the first closed-loop gate drive circuit comprises:

a turn-on wave-shaping circuit configured to shape the first target signal with a first shape during a first portion of the turn-on period and shape the first target signal with a second shape during a second portion of the turn-on period; and

wherein the first closed-loop gate drive circuit is configured to generate the first gate control signal in response to the first target signal and the drain-source current through the first semiconductor switch.

54. The load control device of claim 52, wherein the first closed-loop gate drive circuit configured to:

shape the first drive signal during a turn-on period to generate a first target signal
receive a step signal a predetermined time delay after receiving the first drive signal from the control circuit;
set the first target signal to the step signal upon receiving the step signal; and
generate the first gate control signal in response to the first target signal and the drain-source current through the first semiconductor switch.

55. The load control device of claim 54, wherein the step signal is the first drive signal.

56. The load control device of claim 51, wherein the control circuit is configured to:
receive an overcurrent signal from the first closed-loop gate drive circuit in response to an overcurrent detection circuit detecting the overcurrent condition; and
cease generating the first drive signal in response to receiving the overcurrent signal.

57. The load control device of claim 51, wherein the overcurrent protection circuit is configured to determine a parameter associated with the first semiconductor switch, and set a trip time period for the first semiconductor switch based on the parameter; and
wherein the first closed-loop gate drive circuit is configured to cease generating the first gate control signal to control the first semiconductor switch based on an expiration of the trip time period.

58. The load control device of claim 57, wherein the parameter associated with the first semiconductor switch comprises one or more of a temperature across the first semiconductor switch, a power of the first semiconductor switch, or a drain voltage developed across the first semiconductor switch.

59. The load control device of claim 57, wherein the overcurrent protection circuit configured to determine the parameter associated with the first semiconductor switch based on detecting a drain voltage developed across the first semiconductor switch via a drain voltage sense circuit coupled in series with the first semiconductor switch.

60. The load control device of claim 59, wherein the trip time period is inversely proportional to a drain voltage developed across the first semiconductor switch.

61. The load control device of claim 57, wherein the trip time period based on a duration that the drain-source current through the first semiconductor switch is reaching a predetermined level.

62. The load control device of claim 51, wherein the overcurrent protection circuit is configured to send a reset signal to the first closed-loop gate drive circuit upon reaching on a next half cycle of an AC mains line voltage received from the AC power source.

63. The load control device of claim 51, wherein the first closed-loop gate drive circuit comprises the overcurrent protection circuit and a first voltage amplifier circuit; and wherein the overcurrent protection circuit is configured to control an input of the first voltage amplifier circuit based on detecting the overcurrent condition.

64. A load control device configured to control power delivered from an AC power source to an electrical load, the load control device comprising:
a hot terminal adapted to be electrically coupled to a hot side of the AC power source;
a dimmed-hot terminal adapted to be electrically coupled to the electrical load;

a neutral terminal;

a controllable conductive device coupled in series with the electrical load, the controllable conductive device comprising a first semiconductor switch and a second semiconductor switch;

a control circuit; and

a first closed-loop gate drive circuit configured to generate a first gate control signal in response to receiving a first drive signal and a first feedback signal that is indicative of a drain-source current across the first semiconductor switch;

wherein the first closed-loop gate drive circuit comprises an overcurrent protection circuit configured to determine a trip time period for the first semiconductor switch based on a parameter associated with the first semiconductor switch, and

wherein the first closed-loop gate drive circuit is configured to cease generating the first gate control signal based on the first gate control signal being at a current limit during the trip time period.

65. The load control device of claim 64, wherein, during an overcurrent condition, the first closed-loop gate drive circuit is configured to maintain the first gate control signal at the current limit during the trip time period.

66. The load control device of claim 64, wherein the parameter associated with the first semiconductor switch comprises one or more of a temperature across the first semiconductor switch, a power of the first semiconductor switch, or a drain voltage developed across the first semiconductor switch.

67. The load control device of claim 64, wherein the control circuit is configured to: receive an overcurrent signal from the first closed-loop gate drive circuit in response to an overcurrent detection circuit detecting an overcurrent condition; and cease generating the first drive signal in response to receiving the overcurrent signal.

68. The load control device of claim 64, wherein the first closed-loop gate drive circuit comprises an overcurrent detection circuit that is coupled in series with the overcurrent protection circuit, the overcurrent detection circuit configured to:

- receive the first gate control signal;
- receive a step signal from a step-up circuit;
- determine the first gate control signal is over a current limit;
- generate an overcurrent voltage based on the determination; and
- provide the overcurrent voltage to the overcurrent protection circuit.

69. A load control device configured to control power delivered from an AC power source to an electrical load, the load control device comprising:

- a hot terminal adapted to be electrically coupled to a hot side of the AC power source;
- a dimmed-hot terminal adapted to be electrically coupled to the electrical load;
- a neutral terminal;
- a controllable conductive device coupled in series with the electrical load, the controllable conductive device comprising a first semiconductor switch and a second semiconductor switch;
- a control circuit;
- a first voltage amplifier circuit configured to generate a first gate control signal for controlling the first semiconductor switch;
- an overcurrent detection circuit configured to receive the first gate control signal, detect an overcurrent condition based on the first gate control signal, and generate an overcurrent signal upon detection of the overcurrent condition; and
- an overcurrent protection circuit configured to receive the overcurrent signal, determine a parameter associated with the first semiconductor switch, and control an input to the first voltage amplifier circuit based on the overcurrent signal and the parameter.

70. The load control device of claim 69, wherein the overcurrent protection circuit is configured to set a trip time period based on the parameter.

71. The load control device of claim 70, wherein, during the overcurrent condition, the first voltage amplifier circuit is configured to maintain the first gate control signal at a current limit during the trip time period.

72. The load control device of claim 69, wherein the control circuit is configured to: receive the overcurrent signal from the overcurrent detection circuit; and cease generating the first gate control signal in response to receiving the overcurrent signal.

73. A method for detecting an overcurrent condition in a load control device that is configured to control power delivered from an AC power source to an electrical load, the method comprising:

retrieving a target drive level at a firing time within a half-cycle of an AC lines voltage of the AC power source;

receiving a feedback signal indicative of a magnitude of a load current conducted through the semiconductor switch;

determining a gate control signal based on the feedback and the target drive level, the gate control signal for controlling a gate of a semiconductor switch that is configured to conduct the load current through the electrical load; and

detecting an overcurrent condition in the semiconductor switch in response to the gate control signal.

74. The method of claim 73, further comprising:
decreasing the magnitude of the gate control signal to zero volts in response to detecting the overcurrent condition.

75. The method of claim 73, further comprising:
rendering the semiconductor switch non-conductive in response to detecting the overcurrent condition.

76. The method of claim 73, further comprising:

alerting a user of the overcurrent condition in response to detecting the overcurrent condition.

77. The method of claim 73, wherein the target drive level changes with respect to the time within a turn-on period

78. The method of claim 77, further comprising:
setting the target drive level equal to a predetermined level at the end of the time-on period;
and
detecting the overcurrent condition in the semiconductor switch when the magnitude of the gate control signal is equal to the predetermined level.

79. The method of claim 78, further comprising:
rendering the semiconductor switch non-conductive when the magnitude of the gate control signal is equal to the predetermined level for the length of a trip time period after the overcurrent condition is detected.

80. The method of claim 79, wherein the trip time period is based on a parameter of the semiconductor switch.

81. The method of claim 80, wherein the parameter of the semiconductor switch comprises one or more of a temperature across the semiconductor switch, a power of the semiconductor switch, or a voltage developed across the semiconductor switch.

82. The method of claim 80, wherein the length of the trip time period is inversely proportional to a value of the parameter of the semiconductor switch.

83. The method of claim 73, further comprising:
adjusting a magnitude of the gate control signal in response to a magnitude of the feedback signal to adjust the magnitude of the load current towards a target current indicated by a magnitude of the target signal.

84. The method of claim 73, further comprising:
generating the target drive level at the firing time; and
shaping the target drive level with respect to the time within a turn-on period.

85. The method of claim 73, further comprising:
generating a gate control signal for controlling an impedance of the semiconductor switch;
receiving a first feedback signal indicative of a magnitude of the load current conducted through the semiconductor switch;
adjusting a magnitude of the gate control signal in response to the first feedback signal to control the magnitude of the load current towards a target value.

86. A method for controlling power delivered from an AC power source to an electrical load by a load control device, the load control device comprising a semiconductor switch adapted to be coupled in series between the AC power source and the electrical load and configured to conduct a load current through the electrical load, the method comprising:

rendering the semiconductor switch conductive at a firing time during a half-cycle of the AC power source using a forward phase control technique;

generating a gate control signal for controlling an impedance of the semiconductor switch when the semiconductor switch is conductive;

receiving a first feedback signal indicative of a magnitude of the load current conducted through the semiconductor switch;

adjusting a magnitude of the gate control signal in response to the first feedback signal to control the magnitude of the load current towards a target value; and

detecting an overcurrent condition in the semiconductor switch in response to the gate control signal.

87. The method of claim 86, further comprising:
setting the target value to a maximum current value after the semiconductor switch is rendered conductive; and

detecting the overcurrent condition in the semiconductor switch when the gate control signal is equal to the target value.

88. The method of claim 87, wherein detecting the overcurrent condition further comprises detecting an overcurrent condition in the semiconductor switch when the gate control signal is equal to the target value at the end of a trip time that starts when the target value is set to the maximum current value.

89. The method of claim 88, further comprising:
receiving a second feedback signal indicating a parameter of the semiconductor switch; and
adjusting the trip time in response to the second feedback signal.

90. The method of claim 87, further comprising:
shaping the target value with respect to time during a turn-on period from zero to a rated current value in response to the second feedback signal exceeding the threshold.

91. The method of claim 90, wherein setting the target value to the maximum current value comprises increasing the target value from the rated current value to the maximum current value at an end of the turn-on period.

92. The method of claim 86, further comprising:
decreasing the magnitude of the gate control signal to zero volts in response to detecting the overcurrent condition.

93. The method of claim 86, further comprising:
rendering the semiconductor switch non-conductive in response to detecting the overcurrent condition.

94. The method of claim 86, further comprising:
alerting a user of the overcurrent condition in response to detecting the overcurrent condition.

95. The method of claim 86, wherein the target drive level changes with respect to the time within a turn-on period

96. The method of claim 86, further comprising:
setting the target drive level equal to a predetermined level at the end of a turn-on period; and
detecting the overcurrent condition in the semiconductor switch when the magnitude of the gate control signal is equal to the predetermined level.

97. The method of claim 96, further comprising:
rendering the semiconductor switch non-conductive when the magnitude of the gate control signal is equal to the predetermined level for the length of a trip time period after the overcurrent condition is detected.

98. The method of claim 97, wherein the trip time period is based on a parameter of the semiconductor switch.

99. The method of claim 98, wherein the parameter of the semiconductor switch comprises one or more of a temperature across the semiconductor switch, a power of the semiconductor switch, or a voltage developed across the semiconductor switch.

100. The method of claim 98, wherein the length of the trip time period is inversely proportional to a value of the parameter of the semiconductor switch.

101. The method of claim 86, further comprising:
generating the target drive level at the firing time; and
shaping the target drive level with respect to the time within a turn-on period.

102. The method of claim 86, wherein the load control device comprises a controllably conductive device adapted to be coupled in series between the AC power source and the electrical load, and the controllably conductive device comprising the semiconductor switch.

103. A method for controlling power delivered from an AC power source to an electrical load by a load control device, the load control device comprising a semiconductor switch adapted to be coupled in series between the AC power source and the electrical load and configured to conduct a load current through the electrical load, the method comprising:

- generating a gate control signal for controlling an impedance of the semiconductor switch;
- receiving a first feedback signal indicative of a magnitude of the load current conducted through the semiconductor switch;
- adjusting a magnitude of the gate control signal in response to the first feedback signal to control the magnitude of the load current towards a target value;
- setting the target value to a predetermined value at a firing time within a half-cycle of an AC lines voltage of the AC power source;
- linearly decreasing the target value with respect to time from the predetermined value to an intermediate value while a second feedback signal is below a threshold, the second feedback signal indicating a magnitude of a voltage developed across the semiconductor switch; and
- shaping the target value with respect to time during a turn-off period from the intermediate value to zero in response to the second feedback signal exceeding the threshold.

104. The method of claim 103, wherein setting the target value to the predetermined value at the firing time further comprises decreasing the target value from a maximum current value to the predetermined value.

105. The method of claim 103, wherein the predetermined value is a rated current magnitude.

106. The method of claim 103, wherein the second feedback signal comprises a drain voltage sense signal.

107. The method of claim 103, wherein the intermediate value is equal to the target value when the second feedback signal exceeds the threshold.

108. The method of claim 103, further comprising:
generating, during a turn-off period, the gate control signal in response to the second feedback signal.

109. The method of claim 103, wherein generating the gate control signal comprises generating the gate control signal for controlling the impedance of the semiconductor switch the using a reverse phase control technique.

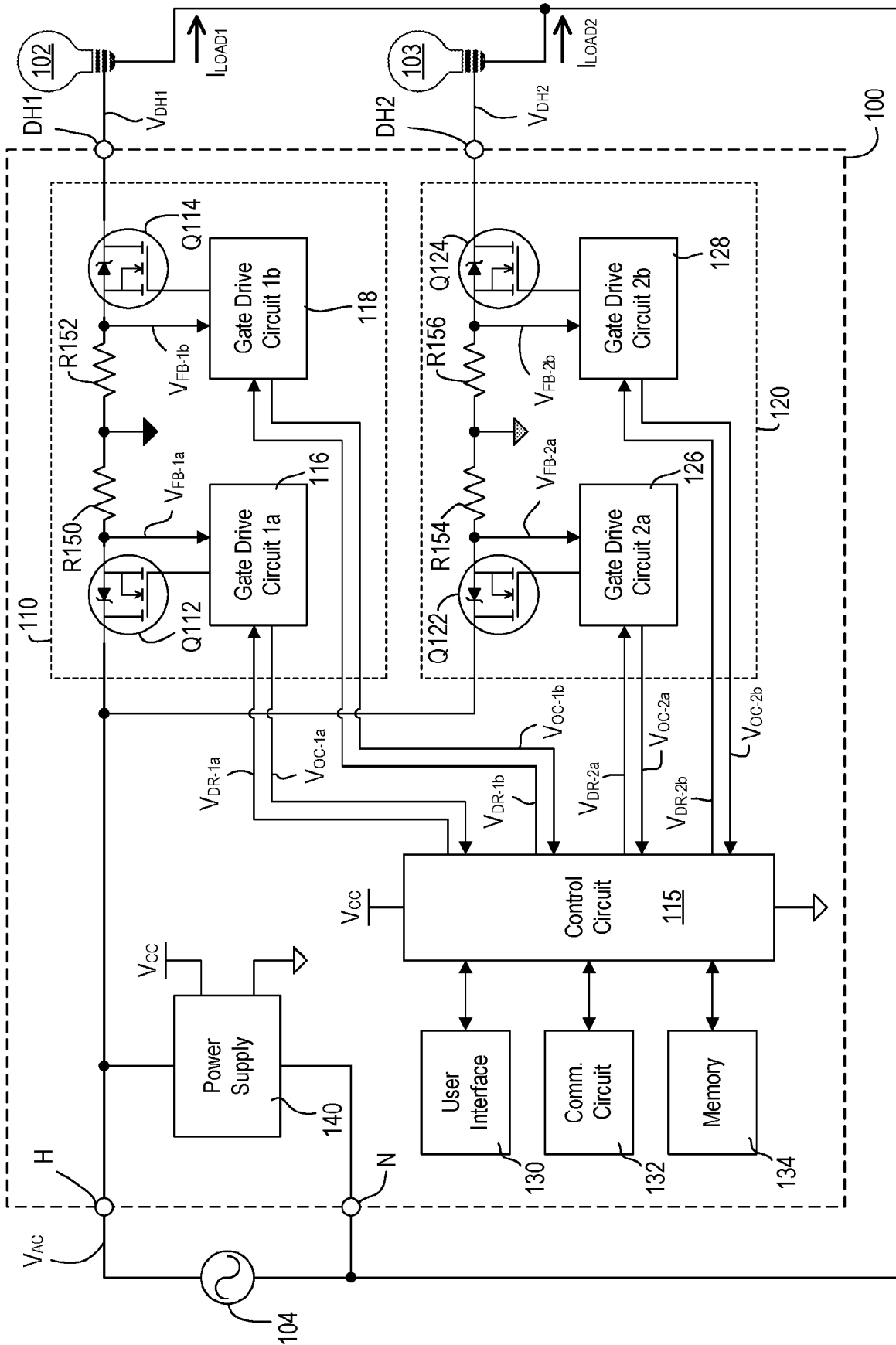

FIG. 1

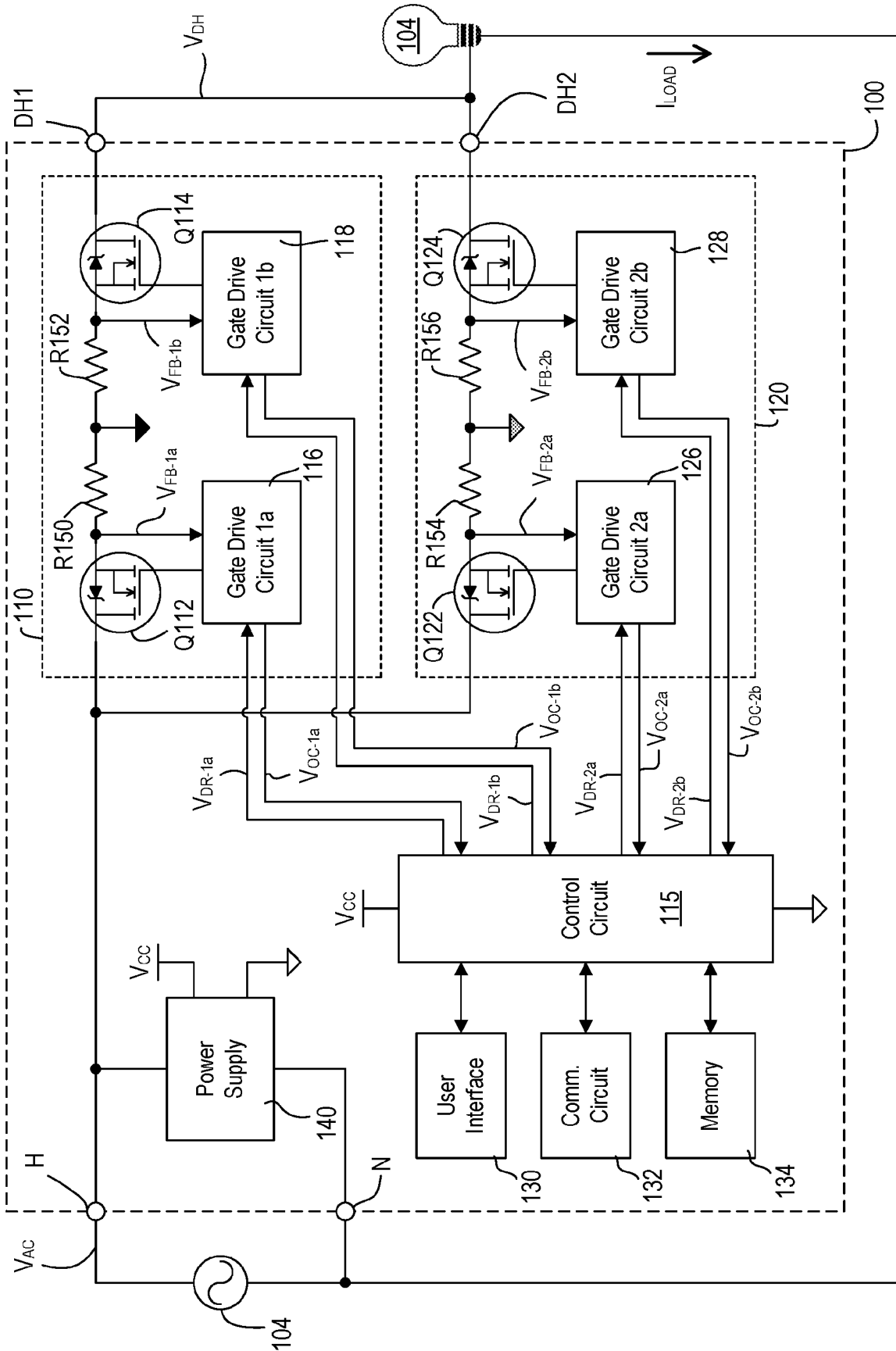

FIG. 2

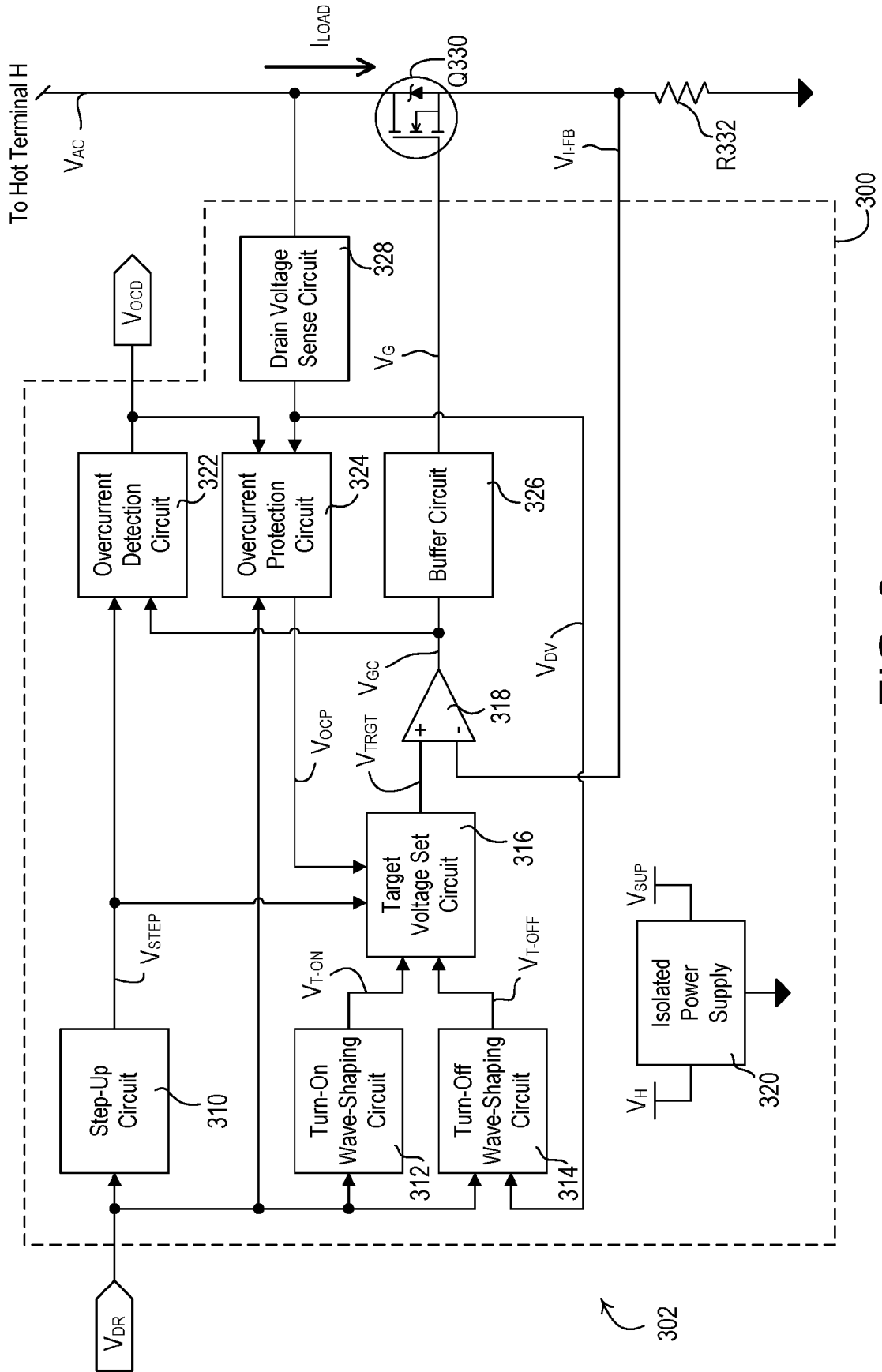

FIG. 3

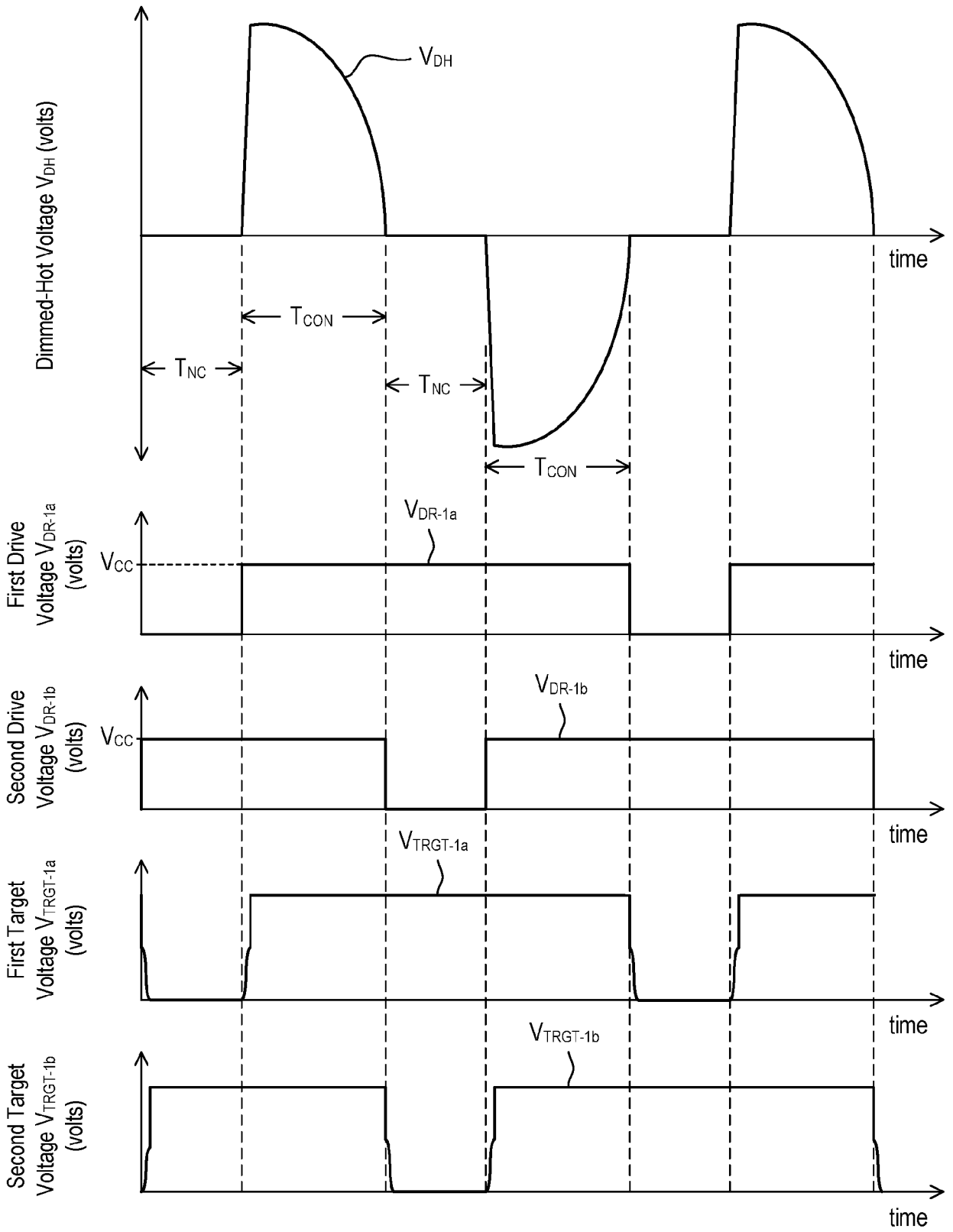

FIG. 4

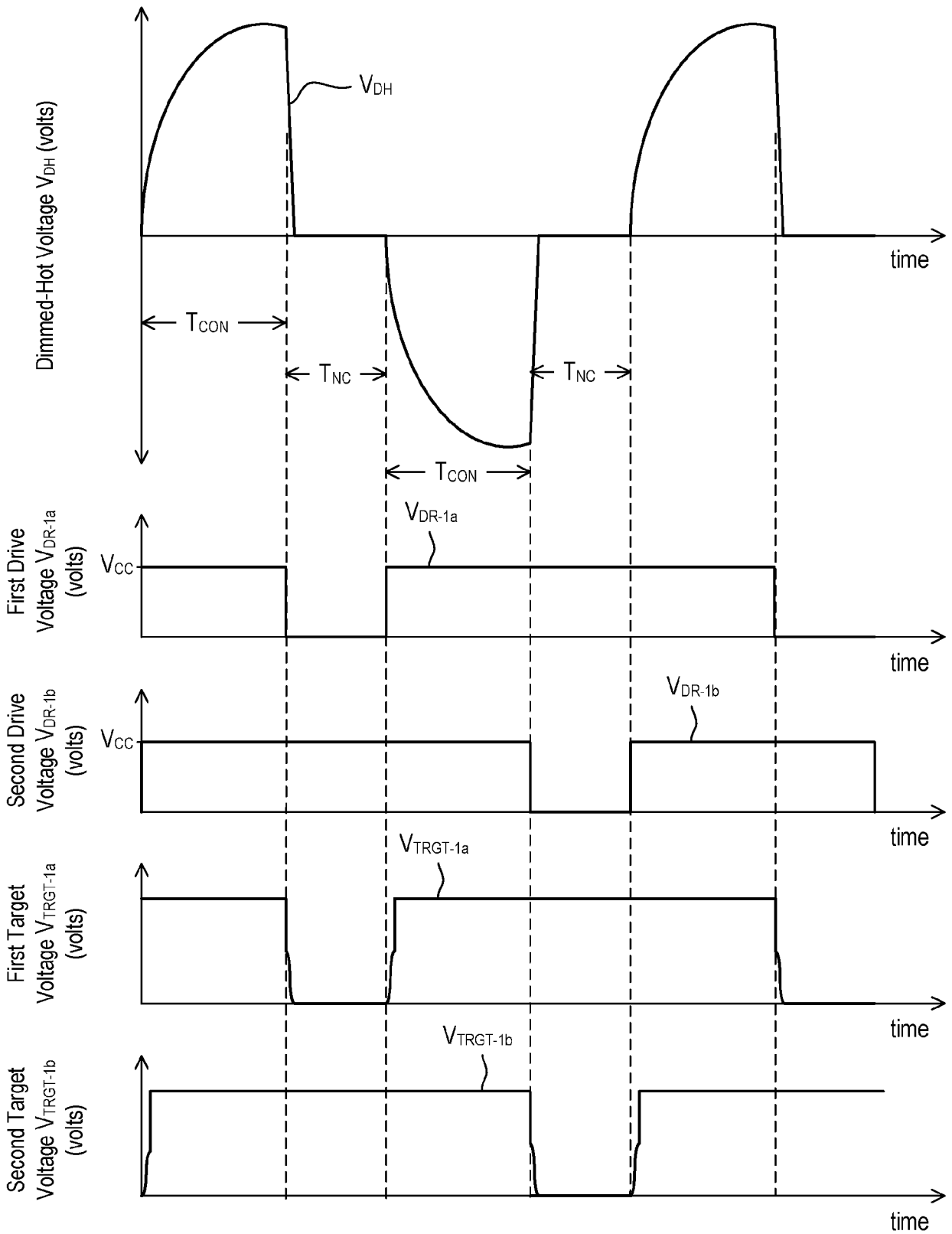

FIG. 5

6/11

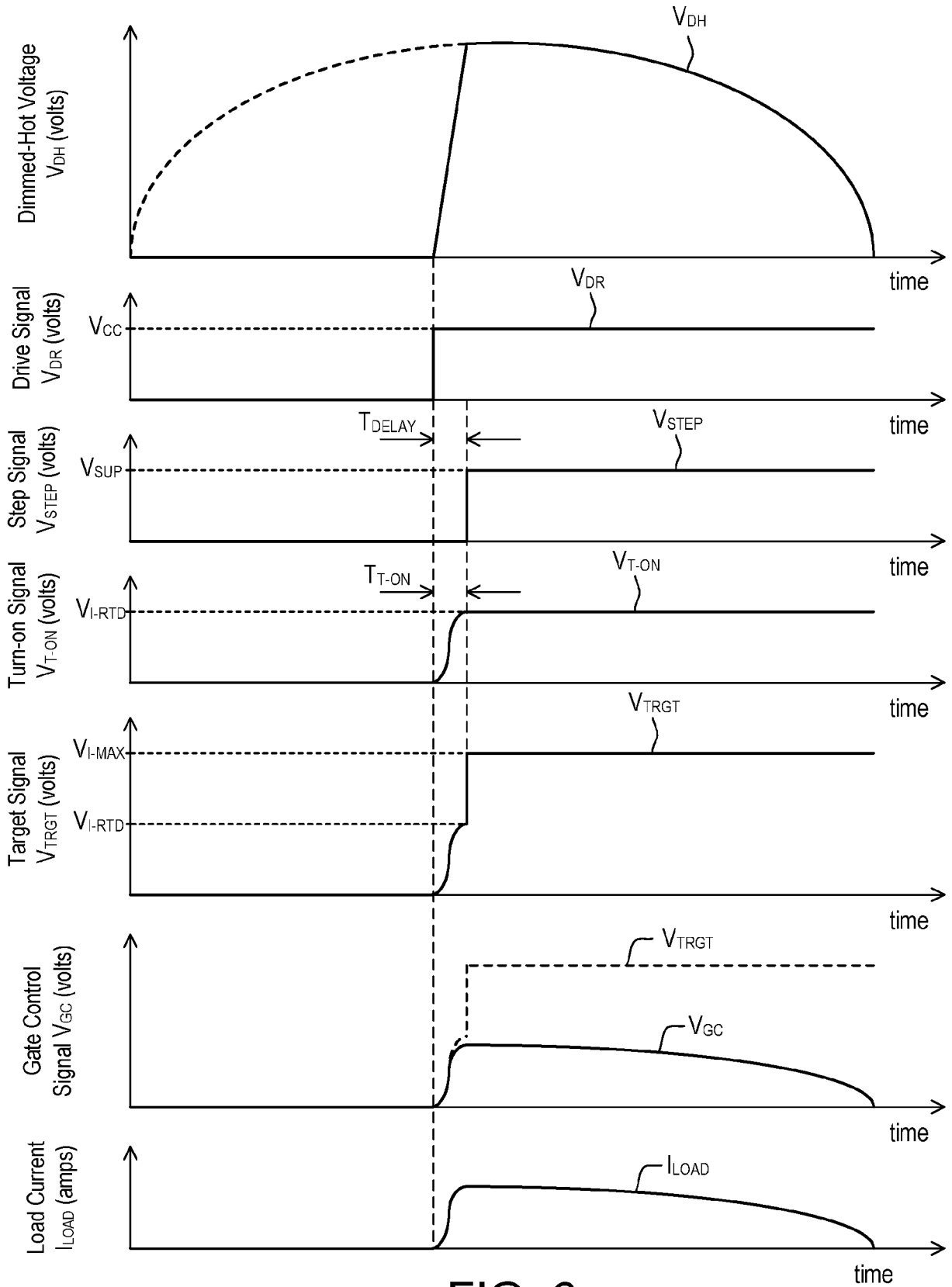

FIG. 6

7/11

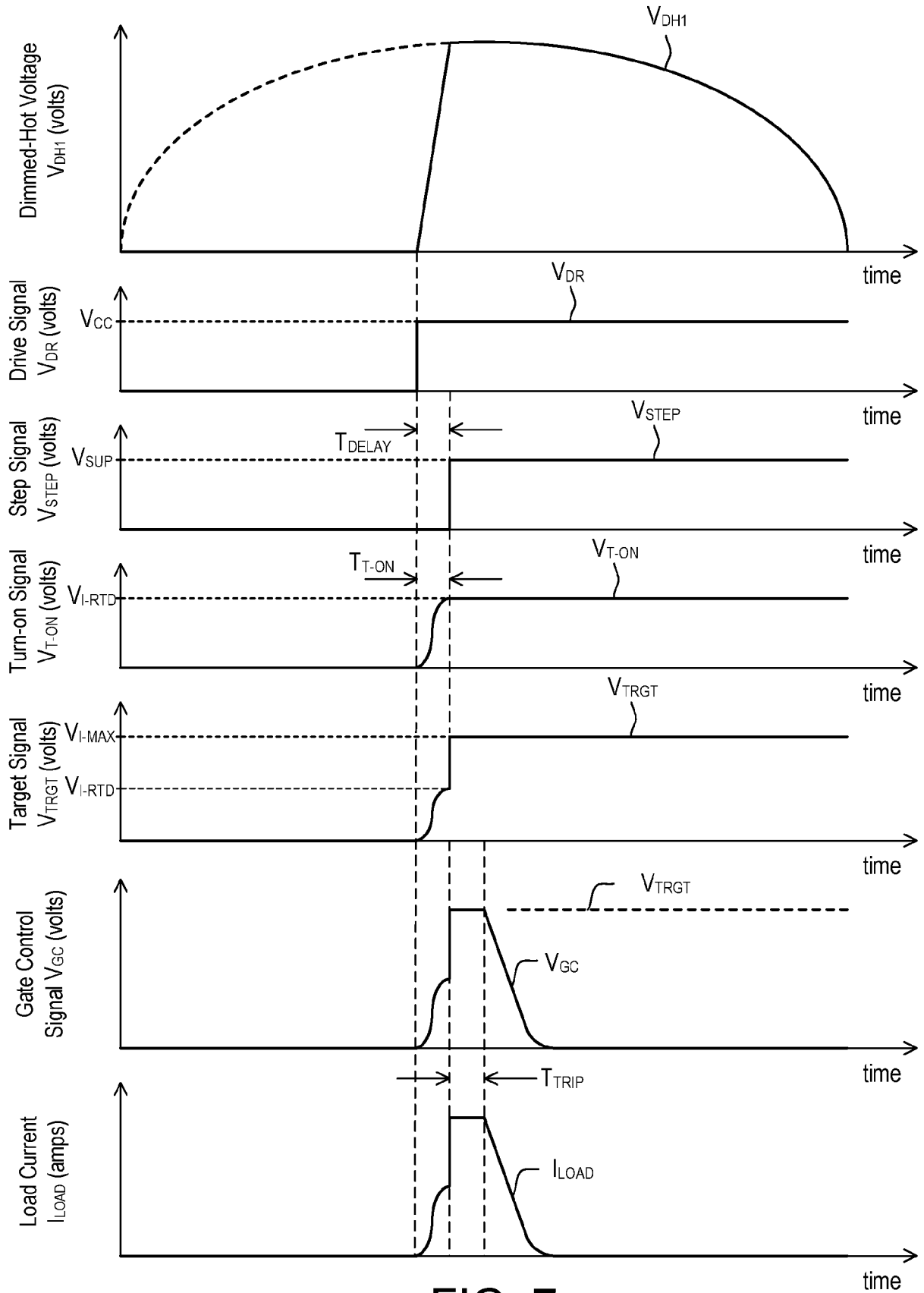

FIG. 7

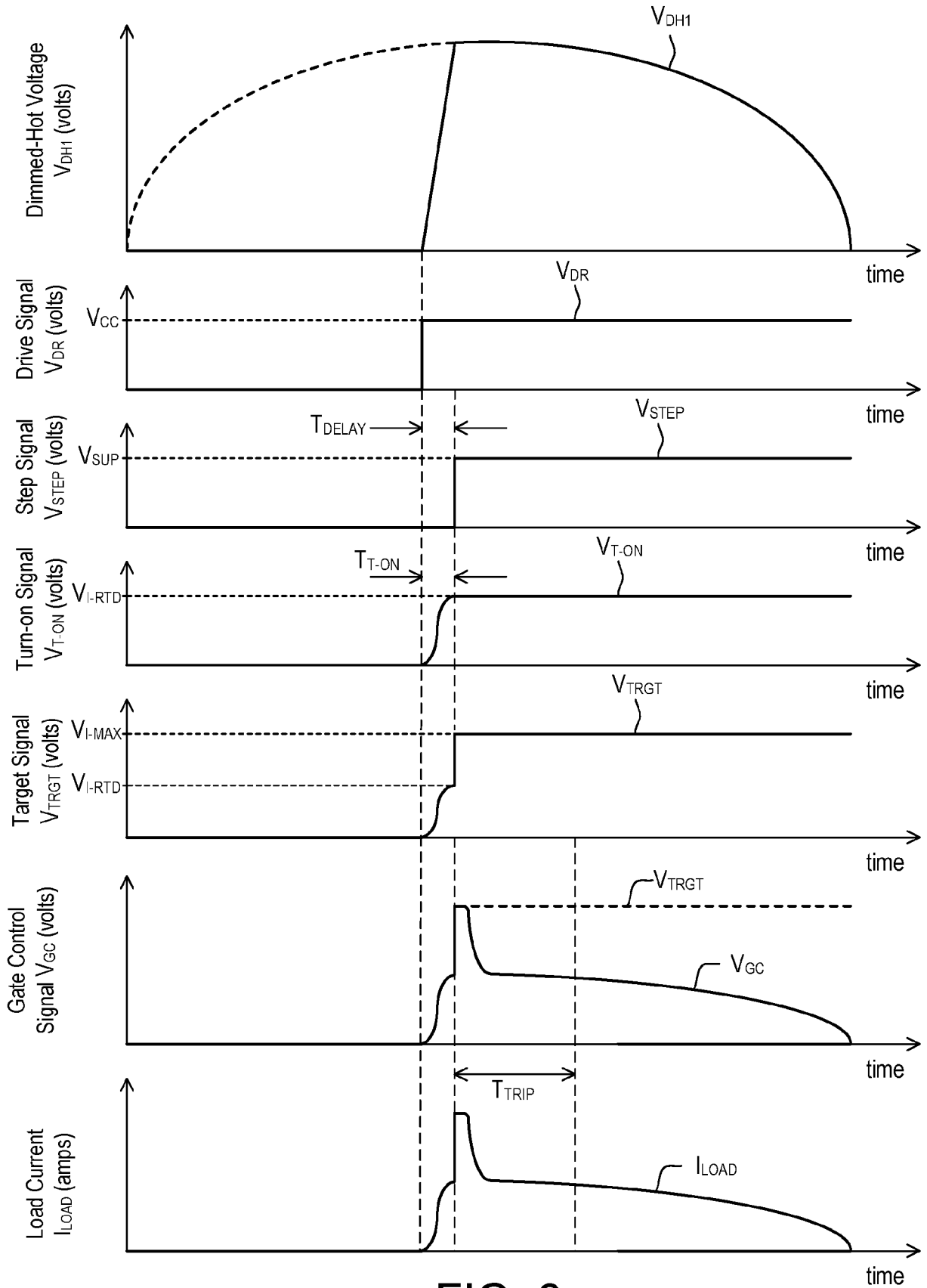

FIG. 8

9/11

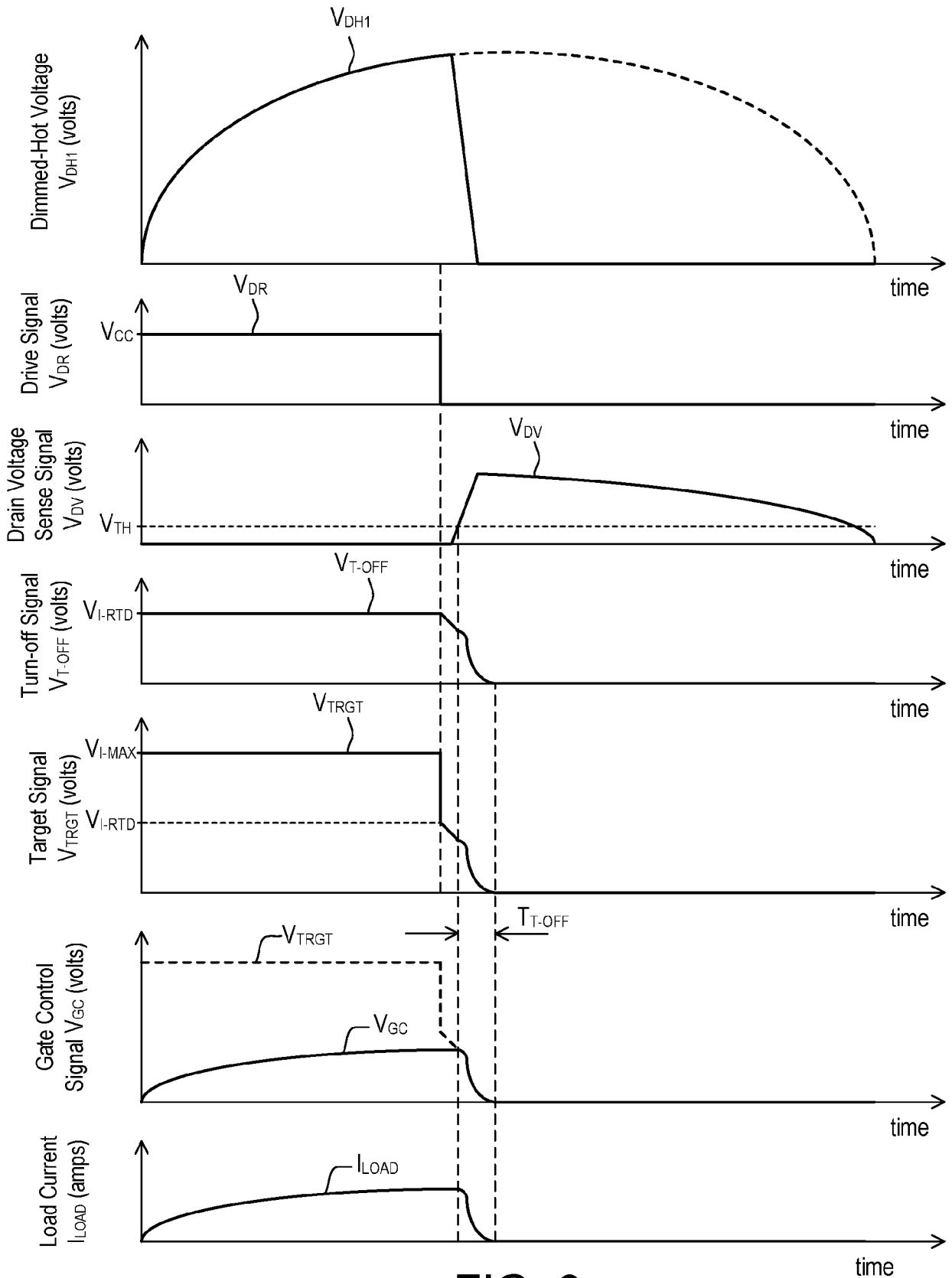

FIG. 9

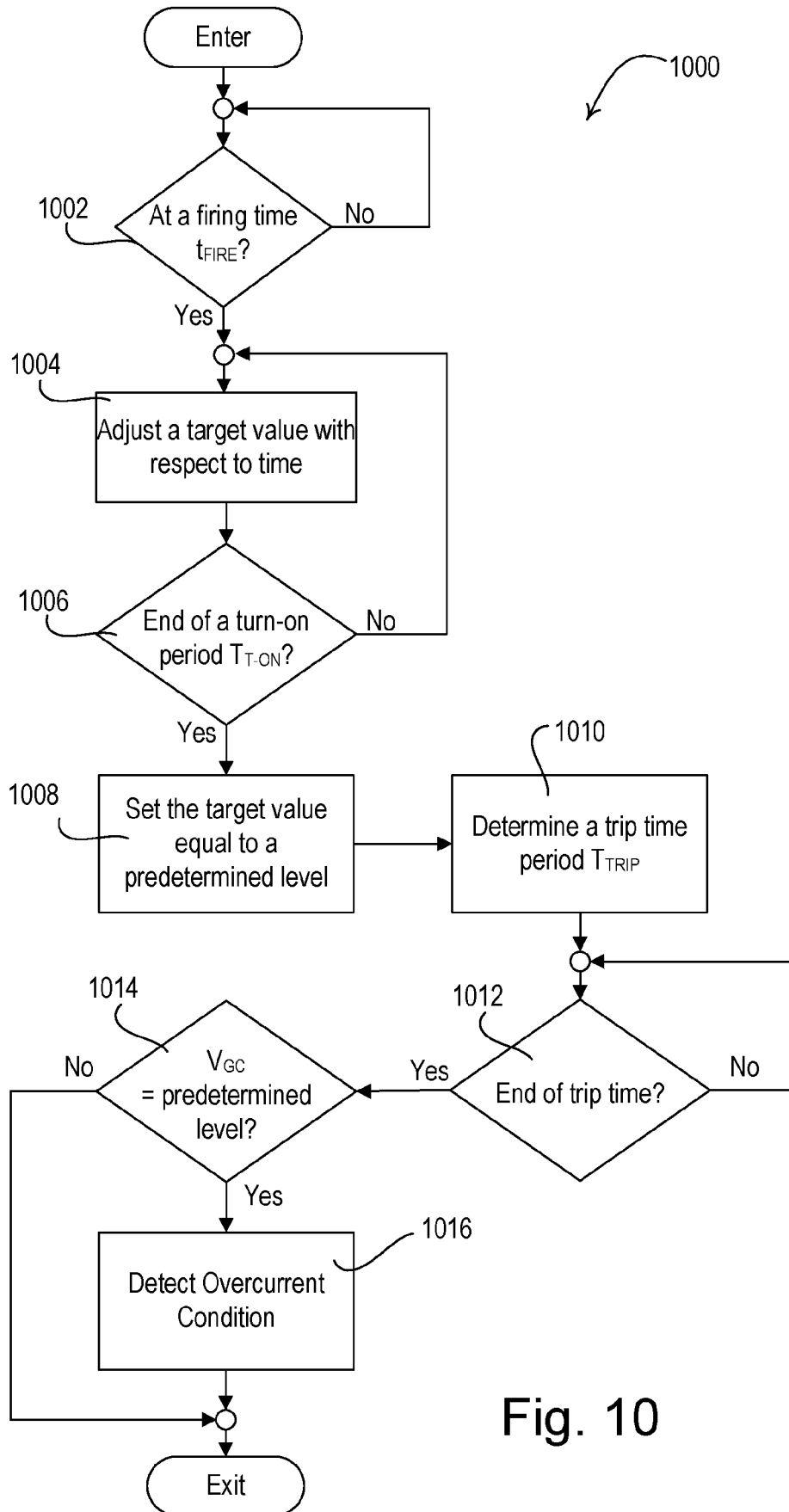

Fig. 10

11/11

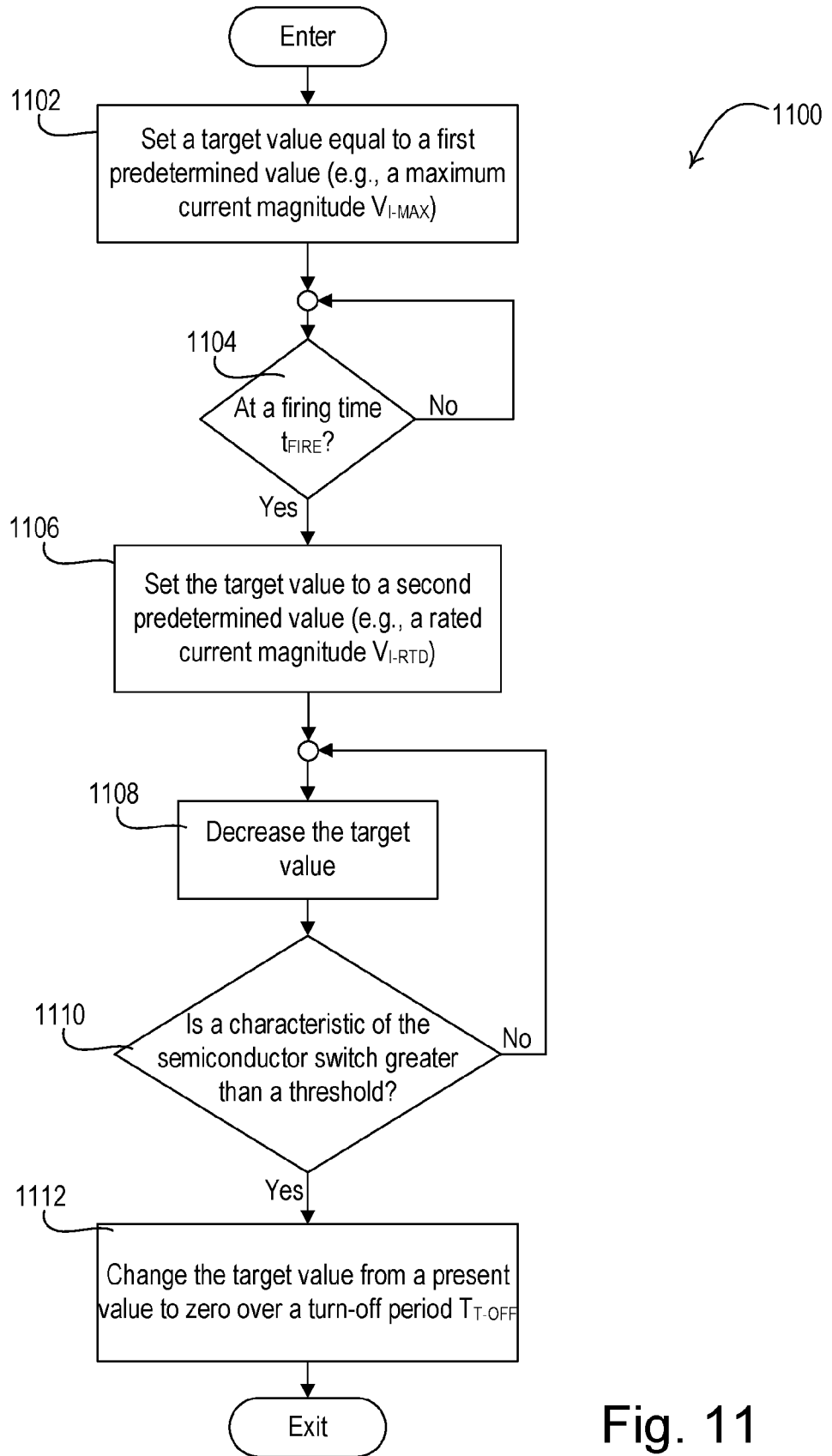

Fig. 11

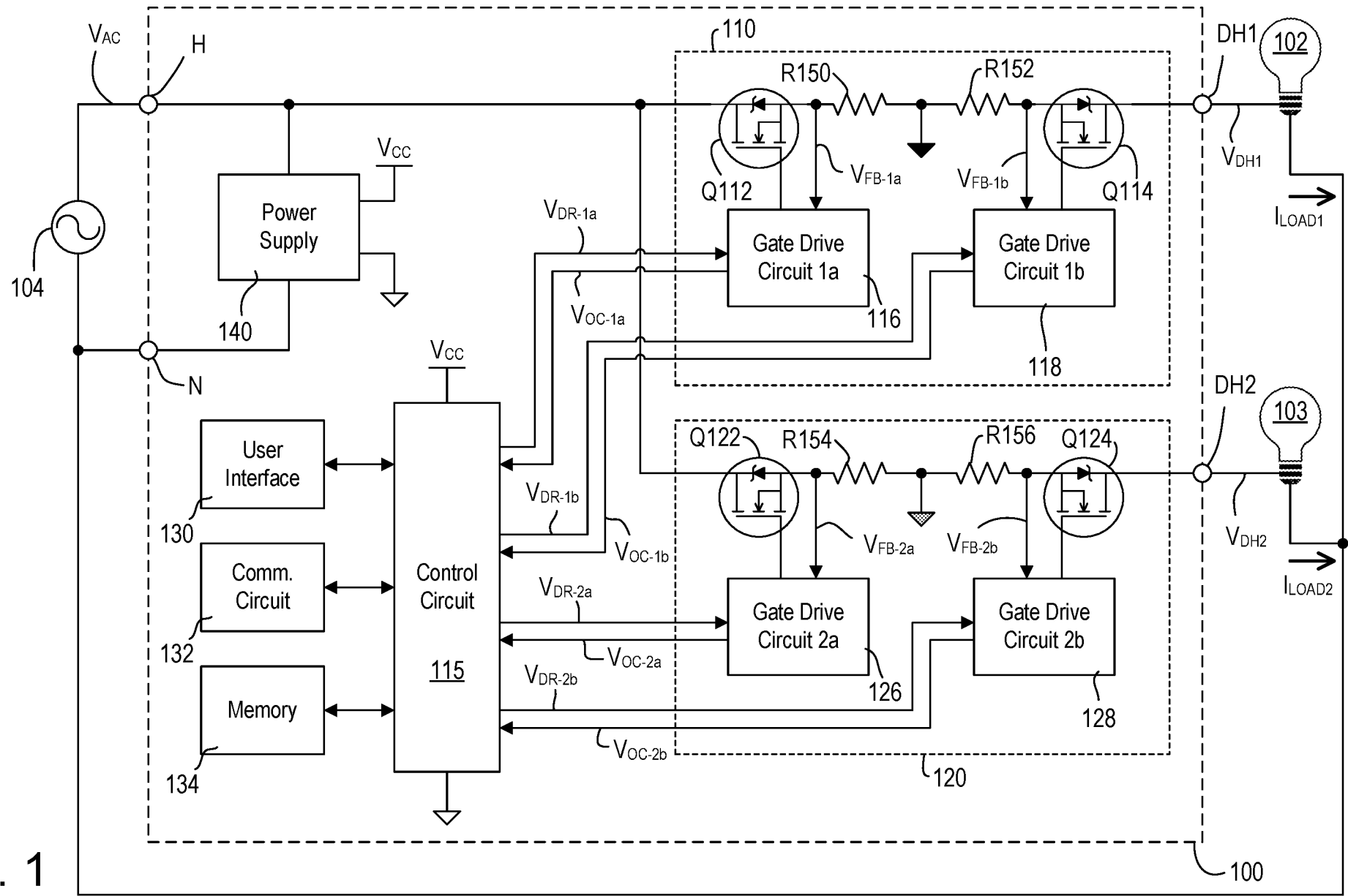

FIG. 1