

(19) World Intellectual Property Organization
International Bureau



(43) International Publication Date
8 September 2006 (08.09.2006)

PCT

(10) International Publication Number
WO 2006/094260 A2

- (51) International Patent Classification:
A47C 1/03 (2006.01)
- (21) International Application Number:
PCT/US2006/007821
- (22) International Filing Date: 1 March 2006 (01.03.2006)
- (25) Filing Language: English
- (26) Publication Language: English
- (30) Priority Data:
60/657,632 1 March 2005 (01.03.2005) US
- (71) Applicant (for all designated States except US): **HA-WORTH, INC.** [US/US]; One Haworth Center, 1400 Highway M-40, Holland, Michigan 49423 (US).
- (72) Inventors; and
- (75) Inventors/Applicants (for US only): **COOK, Tracy** [US/US]; P.O. Box 223, Douglas, Michigan 49406 (US). **GESSLER, Brian** [US/US]; 7145 Pine Oak Lane, Hudsonville, Michigan 49426 (US). **SHOEMAKER, Keith** [US/US]; 11597 Chris Dr., Holland, Michigan 49424

(US). **FOOKES, Tim** [US/US]; 3849 Sun Tree Ave., Hudsonville, Michigan 49426 (US). **ROELS, Rick** [US/US]; 3508 Fawn View Drive, Zeeland, Michigan 49464 (US).

(74) Agents: **MAKI, Mark, L.** et al.; FLYNN, THIEL, BOUTELL & TANIS, P.C., 2026 Rambling Road, Kalamazoo, Michigan 49008-1631 (US).

(81) Designated States (unless otherwise indicated, for every kind of national protection available): AE, AG, AL, AM, AT, AU, AZ, BA, BB, BG, BR, BW, BY, BZ, CA, CH, CN, CO, CR, CU, CZ, DE, DK, DM, DZ, EC, EE, EG, ES, FI, GB, GD, GE, GH, GM, HR, HU, ID, IL, IN, IS, JP, KE, KG, KM, KN, KP, KR, KZ, LC, LK, LR, LS, LT, LU, LV, LY, MA, MD, MG, MK, MN, MW, MX, MZ, NA, NG, NI, NO, NZ, OM, PG, PH, PL, PT, RO, RU, SC, SD, SE, SG, SK, SL, SM, SY, TJ, TM, TN, TR, TT, TZ, UA, UG, US, UZ, VC, VN, YU, ZA, ZM, ZW.

(84) Designated States (unless otherwise indicated, for every kind of regional protection available): ARIPO (BW, GH, GM, KE, LS, MW, MZ, NA, SD, SL, SZ, TZ, UG, ZM, ZW), Eurasian (AM, AZ, BY, KG, KZ, MD, RU, TJ, TM),

[Continued on next page]

(54) Title: ARM ASSEMBLY FOR A CHAIR

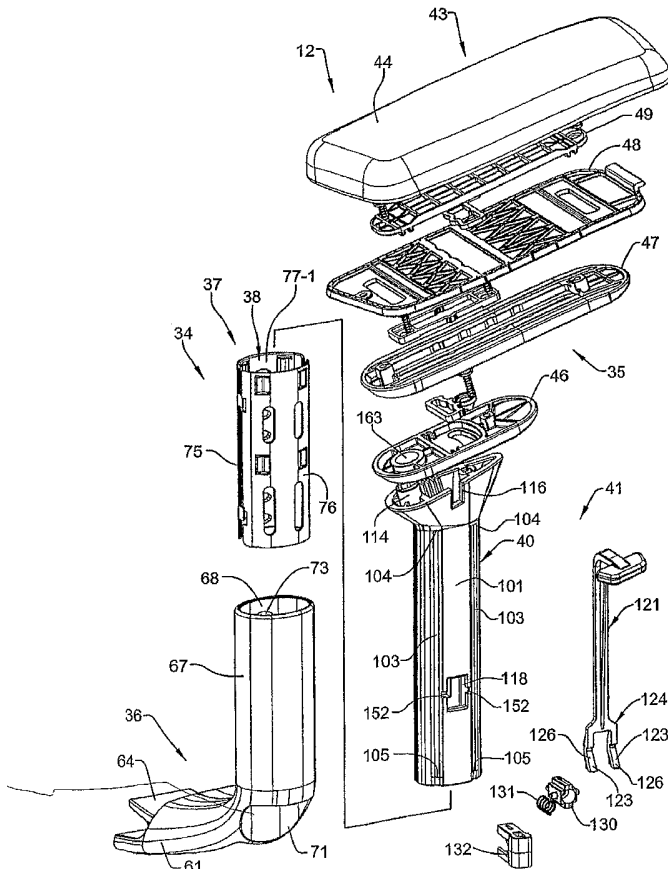

(57) Abstract: An office chair is provided with includes a chair arm assembly on each opposite side thereof for supporting the arms of a user. The arm assemblies each include a latching assembly to permit adjustment of the height of an arm cap thereof while maintaining the arm cap at a selected elevation. The latch assembly is engageable with an inner liner provided within a support post. Further, the armrest assembly has a plurality of interconnected and relatively movable plates which permit adjustment of the angular orientation of the arm cap along with adjustment of the arm cap in the front-to-back direction and the side-to-side direction.

WO 2006/094260 A2



European (AT, BE, BG, CH, CY, CZ, DE, DK, EE, ES, FI, FR, GB, GR, HU, IE, IS, IT, LT, LU, LV, MC, NL, PL, PT, RO, SE, SI, SK, TR), OAPI (BF, BJ, CF, CG, CI, CM, GA, GN, GQ, GW, ML, MR, NE, SN, TD, TG).

For two-letter codes and other abbreviations, refer to the "Guidance Notes on Codes and Abbreviations" appearing at the beginning of each regular issue of the PCT Gazette.

Published:

- *without international search report and to be republished upon receipt of that report*

ARM ASSEMBLY FOR A CHAIR

CROSS REFERENCE TO RELATED APPLICATION

[0001] This application claims the benefit of U.S. Provisional Application No. 60/657 632, filed March 1, 2005.

FIELD OF THE INVENTION

[0002] The invention relates to an improved arrangement of an arm assembly for an office chair, and more particularly, to an arm assembly wherein the elevation, angular, longitudinal and transverse positions of an arm cap are readily adjustable.

BACKGROUND OF THE INVENTION

[0003] Conventional office chairs are designed to provide significant levels of comfort and adjustability. Such chairs typically include a base which supports a tilt control assembly to which a seat assembly and back assembly are movably interconnected. The tilt control mechanism includes a back upright which extends rearwardly and upwardly and supports the back assembly rearwardly adjacent to the seat assembly. The tilt control mechanism serves to interconnect the seat and back assemblies so that they may tilt rearwardly together in response to movements by the chair occupant and possibly to permit limited forward tilting of the seat and back. Further, such chairs typically permit the back to also move relative to the seat during such rearward tilting.

[0004] In addition to supporting the seat and back of the occupant, the chair also may include support assemblies that support the occupant's body at various locations thereof. One primary support assembly of this type is an arm assembly wherein an arm assembly is mounted on each opposite side of the seat so as to support the arms and specifically, the elbows and forearms of the occupant. Such arm assemblies project upwardly and include an upward facing armrest thereon which armrest defines a support surface to accommodate the occupant's arms.

[0005] However, one difficulty associated with the design of conventional office chairs is the fact that office workers have different physical characteristics and comfort preferences such that it is difficult to design a single chair configuration that satisfies the preferences of the different individuals who might purchase such a chair.

[0006] To accommodate these differences, it is known to provide arm assemblies which allow for adjustment of the height of the armrest as well as the relative location of the armrest relative to the seat assembly. An armrest therefore may be movable in its angular orientation as well as its position in the front-to-back direction as well as the side-to-side direction.

[0007] In view of the foregoing, it is an object of the invention to provide an improved arm rest assembly which allows ready configurability thereof while providing improved comfort with respect to the range and combination of motions which are permitted.

[0008] The invention relates to an arm assembly which not only is height adjustable but also permits adjustment of the armrest in the angular, front-to-back and sideward directions. This arm assembly includes a support post mounted to the base of the chair and preferably, the upright thereof so that the armrest moves in unison with the upright during tilting of the chair and maintains the arms in a proper orientation relative to the seat and back of the user when reclining.

[0009] To provide this height-adjustability, the arm assembly includes an armrest assembly having a vertically elongate column that projects downwardly and is slidably received within a tubular support post fixed to the chair frame. This support post includes an arrangement of plastic liner sections which fit within the tube and also define vertically spaced apart recesses that correspond to various elevations at which the armrest may be maintained.

[0010] To maintain the armrest at such elevations, a latch mechanism is provided which comprises a vertically movable

lever disposed within a hollow interior of the armrest column. The latch assembly further includes a cassette assembly which snaps into the side of the column and has a spring-loaded, slidable latch that moves sidewardly into engagement with any of the various recesses located within the post liner. The cassette assembly also engages with the lever and prevents removal thereof.

[0011] The armrest provides three directions of movement in addition to height-adjustability. Specifically, the armrest includes a multi-layer plate arrangement wherein multiple layers of plates are stacked one above the other and are each movable horizontally in an associated direction.

[0012] More particularly, a first pivot plate is pivotally connected to the armrest column and is maintained in a selected angular position by a first detent. The detent defines multiple angular positions at which the armrest may be maintained while also permitting angular movement of the armrest when the stopping threshold or capacity of the detent is overcome as the occupant manually moves the arm cap at the top of the armrest.

[0013] The pivot detent preferably comprises a ring of elastomeric material wherein one sidewall of this ring includes a plurality of angularly spaced recesses that define the various angular positions of the armrest. Deflection of this detent wall therefore permits angular movement and defines the stop capacity of the detent.

[0014] Additionally, a second slide plate is mounted on top of the pivot plate and is slidable relative thereto in the front-to-rear direction. A slide detent is fitted within the slide plate wherein this slide detent is fixed to the pivot plate to fasten the slide plate to the pivot plate. The slide detent also selectively restrains the slide plate while also defining a stop threshold above which, the slide plate may be moved upon the user's manual application of a suitable force to the arm cap. The slide detent is formed somewhat similar to the pivot detent in that it is a ring of elastomeric

material which is deformable. In this case, the slide detent has opposite sidewalls which deflect inwardly.

[0015] Furthermore, an upper transverse subcap plate is slidably supported on the intermediate slide plate through a retainer. The subcap plate is sidewardly or transversely slidable while the retainer carries a resiliently deflectable top detent that engages the subcap plate to maintain the subcap plate in a sidewardly adjusted position while defining a stopping threshold above which a force may be applied to the arm cap to permit sideward adjustment thereof.

[0016] With this arrangement, the arm cap may be readily adjusted vertically as well as horizontally.

[0017] Other objects and purposes of the invention, and variations thereof, will be apparent upon reading the following specification and inspecting the accompanying drawings.

BRIEF DESCRIPTION OF THE DRAWINGS

[0018] Figure 1 is a front elevational view of an office chair having arm assemblies of the invention mounted thereon.

[0019] Figure 2 is a side elevational view of the office chair.

[0020] Figure 3 is a rear isometric view of the chair.

[0021] Figure 4 is a front isometric view of the chair.

[0022] Figure 5 is an exploded view of the arm assembly comprising a support post assembly and an armrest assembly.

[0023] Figure 6 is an exploded view of the armrest assembly.

[0024] Figure 7 is an assembled isometric view of the armrest assembly.

[0025] Figure 8 is a front cross-sectional view of the arm assembly.

[0026] Figure 9 is a side cross-sectional view of the arm assembly.

[0027] Figure 10 is a left side view of a chair upright.

[0028] Figure 11 is a partial exploded cross-sectional view of a connector arrangement between the arm assembly and the upright.

[0029] Figure 12 is a front cross-sectional view of a support post.

[0030] Figure 13 is an inner side view of the support post.

[0031] Figure 14 is a top cross-sectional view of a support column of the armrest assembly as taken along line 14-14 of Figure 25.

[0032] Figure 15 is an isometric view of a locking liner for the support post.

[0033] Figure 16 is a side view of the locking liner.

[0034] Figure 17 is a front view of the locking liner.

[0035] Figure 18 is a cross-sectional end view of the locking liner as taken along line 18-18 of Figure 16.

[0036] Figure 19 is a top cross-sectional view of the locking liner as taken along line 19-19 of Figure 16.

[0037] Figure 20 is an isometric view of a non-locking liner.

[0038] Figure 21 is a side elevational view of the non-locking liner.

[0039] Figure 22 is a top cross-sectional view of the non-locking liner as taken along line 22-22 of Figure 21.

[0040] Figure 23 is an outside side view and partial cross-section of the armrest column.

[0041] Figure 24 is a front view of the armrest column.

[0042] Figure 25 is an inner side view of the armrest column.

[0043] Figure 26 is an enlarged front cross-sectional view of a latch mechanism mounted within the armrest.

[0044] Figure 27 is a front cross-sectional view of the latch assembly.

[0045] Figure 28 is a rear isometric view of a slidable latch for the latch assembly.

[0046] Figure 29 is a rear isometric view of a latch case or housing.

[0047] Figure 30 is a cross-sectional view of the armrest assembly.

[0048] Figure 31 is a plan view of a pivot detent for the armrest assembly for controlling the angular position of the armrest.

[0049] Figure 32 is a plan view of a slide detent for controlling the longitudinal front-to-back position of the armrest.

[0050] Figure 33 is a plan view of a cam detent for controlling the transverse width position of the armrest.

[0051] Figure 34 is a plan view of a pivot plate with the pivot detent therein.

[0052] Figure 35 is a plan view of a slide plate with the cam detent therein.

[0053] Figure 36 is a plan view of a subcap plate with the cam detent therein.

[0054] Figure 37 is a bottom view of a retainer plate with the cam detent supported thereon.

[0055] Figure 38 is a side cross-sectional view of the retainer plate as taken along line 38-38 of Figure 37.

[0056] Certain terminology will be used in the following description for convenience and reference only, and will not be limiting. For example, the words "upwardly", "downwardly", "rightwardly" and "leftwardly" will refer to directions in the drawings to which reference is made. The words "inwardly" and "outwardly" will refer to directions toward and away from, respectively, the geometric center of the arrangement and designated parts thereof. Said terminology will include the words specifically mentioned, derivatives thereof, and words of similar import.

DETAILED DESCRIPTION

[0057] Referring to Figures 1-4, the invention generally relates to an office chair 10 which includes various inventive features therein to improve the overall comfort and adjustability of the chair 10. More particularly, this chair

10 includes improved height-adjustable arm assemblies 12 which are readily adjustable to the different physical characteristics and comfort preferences of the chair's occupant.

[0058] Generally as to the chair 10, this chair 10 includes a base 13 having radiating legs 14 which are supported on the floor by casters 15. The base 12 further includes an upright pedestal 16 which projects vertically and supports a tilt control mechanism 18 on the upper end thereof. The pedestal 16 has a pneumatic cylinder therein which permits adjustment of the height or elevation of the tilt control mechanism 18.

[0059] The tilt control mechanism 18 includes a control body 19 on which a pair of generally L-shaped uprights 20 are pivotally supported by their front ends. The uprights 19 converge rearwardly together to define a connector hub 22 on which is supported the back frame 23 of a back assembly 24. The tilt control mechanism is disclosed in U.S. Provisional Patent Application No. 60/657 524, filed March 1, 2005, entitled TENSION ADJUSTMENT MECHANISM FOR A CHAIR, U.S. Provisional Patent Application Nos. 60/657 541, filed March 1, 2005, and 60/689 723, filed June 10, 2005, both entitled TILT CONTROL MECHANISM FOR A CHAIR, which are owned by Haworth, Inc., the common assignee of the present invention. The disclosures of these patent applications are incorporated herein in their entirety by reference.

[0060] The back assembly 24 has a suspension fabric 25 supported about its periphery on the corresponding periphery of the frame 23 to define a suspension surface 26 against which the back of a chair occupant is supported. The structure of this back assembly 24 is disclosed in U.S. Provisional Patent Application Serial No. 60/657 313, filed March 1, 2005, entitled CHAIR BACK, which is owned by Haworth, Inc. The disclosure of this patent application is incorporated herein in its entirety by reference.

[0061] To provide additional support to the occupant, the back assembly 24 also includes a lumbar support assembly 28

which is configured to support the lumbar region of the occupant's back and is adjustable to improve the comfort of this support. The structure of this lumbar support assembly 28 is disclosed in U.S. Provisional Patent Application Serial No. 60/657 312, filed March 1, 2005, entitled CHAIR BACK WITH LUMBAR AND PELVIC SUPPORTS, which is owned by Haworth, Inc. The disclosure of this patent application is incorporated herein in its entirety by reference.

[0062] Additionally, the chair 10 includes a slidable seat assembly 30 that defines an upward facing support surface 31 on which the seat of the occupant is supported.

[0063] More particularly as to the arm assemblies 12, these arm assemblies 12 are formed substantially identical to each other except that they are formed as mirror-images for mounting to the respective left or right side of the chair. Preferably, these arm assemblies 12 mount directly to the uprights 20 so as to be movable therewith during reclining of the chair 10.

[0064] These uprights 20 are pivotally connected to the tilt control housing 19 and are pivotable about a horizontal axis to effect rearward pivoting movement of the back assembly in unison with more limited, but downward pivoting of the seat assembly 30. The rearward tilting of the back assembly 24 and seat assembly 30 is controlled by the tilt control mechanism 18.

[0065] More particularly as to the arm assembly 12, Figure 5 is an exploded view of the arm assembly 12 which generally comprises a support post unit 30 and an arm cap or armrest assembly 31. The support post unit 30 comprises an upwardly-projecting support post 32 which is rigidly connected to a respective upright 20 and a tubular liner unit 37 which defines an upward-opening hollow interior 38. The hollow post interior 38 is adapted to receive the armrest assembly 35 in telescoping relation therewith.

[0066] More particularly, the armrest assembly 35 comprises a downwardly-projecting support column 40 (Figures 5 and 6)

which is slidably received within the post interior 38 and is vertically movable to a selected elevation. To selectively lock the armrest assembly 35 at a selected elevation, the armrest column 40 includes a latching mechanism 41 disposed within the post column 40 which is adapted to engage the liner 37.

[0067] The armrest assembly 35 further includes an arm cap 43 (Figure 5) that defines an upward facing support surface 44 for supporting the fore arms of the occupant. The arm cap 43 is movably connected to the support column 40 by an interconnected arrangement of stacked plates 46, 47, 48 and 49 (Figures 5 and 6).

[0068] As to these plates, pivot plate 46 pivots relative to the support column 40 to adjust the angular position of the arm cap 43. Slide plate 47 is slidably connected to the pivot plate 46 to thereby adjust the longitudinal, front-to-back position of the arm cap 43. A translatable subcap slide plate 48 is slidably interconnected to the intermediate slide plate 47 so as to be translatable in the transverse or sideward direction to adjust the relative sideward position of the arm cap 43. The subcap plate 48 is fixedly retained on the slide plate 47 by retainer plate 49 as will be discussed in further detail herein. This multi-layer arrangement of plates 46-49 thereby allows a high degree of adjustability for the arm cap 43 to accommodate the physical characteristics and comfort requirements of an occupant.

[0069] Figures 6 and 7 illustrate the components of the arm rest assembly 35 with Figure 6 providing a front exploded view of the arm rest components and Figure 7 providing an assembled view of these same components.

[0070] Referring to Figures 10 and 11 and the connection of the arm assembly 12 to the base 13, the arm assembly 12 is configured for mounting to a respective one of the uprights 20 with the left-side upright 20 being illustrated in Figure 10. It will be understood that the right-side upright 20 is identical to but a mirror image of the left-side upright 20

(Figure 10) and thus, a detailed discussion as to the right-side upright 20 is not required.

[0071] Each upright 20 includes a front end 51 which is configured so as to be pivotally connected to the control body 19 such that the uprights 20 pivot downwardly and upwardly together about a horizontal axis, which extends across the transverse width of the tilt control mechanism 18. Each upright 20 therefore extends rearwardly to an intermediate portion 52 on which is formed an upwardly extending bracket 53 that is adapted to be engaged with and support the seat assembly 30. This intermediate portion 52 further includes a connector section having a generally I-shaped mounting socket 55 for engagement with the support post 36 (Figure 11). The side walls of the mounting socket 55 taper inwardly as illustrated in Figure 11 and terminate at a socket bottom wall 57 which closes off the inner end of the socket 55. The bottom wall 57 is formed with a fastener bore 58 that is adapted to receive a threaded fastener 59 horizontally therethrough from the interior side of the upright 20.

[0072] Turning to the mounting of the arm assemblies 12, (Figures 12 and 13), the support post 36 has a generally L-shaped configuration defined by a horizontal leg 61 which terminates at an inner end 62 and defines an end face 63. Preferably, the entire support post 36 is formed by die casting of rigid metal, such as aluminum.

[0073] The post 36 further includes a connector bayonet 64 that projects sidewardly and has a generally I-shaped cross-sectional configuration as illustrated in Figure 13. This bayonet 64 has tapered side surfaces as best illustrated in Figures 11 and 12 wherein the I-shaped configuration matches the shape of the corresponding socket 55. The distal end of the bayonet 64 is formed with a blind bore 65 that aligns in registry with the fastener bore 58. As such, the bayonet 64 may be plugged into or seated within the socket 55 in tight-fitting, snug engagement and thereafter, the bayonet 64 and upright 20 are drawn sidewardly together and snugly fitted by

threaded engagement of the fastener 59 with the blind bore 65. As such, the post 36 is rigidly fixed on its respective upright 20.

[0074] Referring to Figures 5, 12 and 13, the outermost end of the horizontal leg 61 supports an upright tubular section 67 which has an open upper end 68. The tubular section 67 defines an open interior 69 which interior 69 extends downwardly and opens through a generally oval shaped bottom opening 71. The bottom opening 68 is aligned vertically with the upper opening 68 to define a continuous passage extending vertically through the tubular post section 67.

[0075] On its inside face 72 (Figures 12 and 13), the tubular section 67 includes a row of side ports or cavities 73 which are vertically spaced apart one above the other and open horizontally through the thickness of the post wall.

[0076] The support post unit 34 further includes the aforementioned liner unit 37, which liner unit 37 is formed of a reduced-friction plastic material. As seen in Figures 5 and 8, the liner unit 37 extends circumferentially of the tubular sections 67 and preferably is formed of a two-piece construction comprising a first locking liner 75 and a second non-locking liner 76. The two liners 75 and 76 are each inserted one at a time into the tubular post section 67 and define the interior space into which the support column 40 is slidably inserted. As described in further detail herein, the locking liner 75 is first positioned within the tubular post section 67 and then the non-locking second liner 76 is inserted into position. The locking liner 75 is further configured to cooperate with the latching mechanism 41 to selectively prevent vertical adjustment of the elevation of the arm rest assembly 35.

[0077] Referring to Figures 15-19, these figures illustrate the locking liner 75. The locking liner 75 has an arcuate cross sectional shape (Figure 19) which conforms to the inside face and shape of the tubular post section 67. This shape is

defined by the liner side wall 77 which is formed of a molded plastic having various features incorporated therein.

[0078] First as to these features, the liner side wall 77 includes a plurality of hollow locking projections 79, the number, location and shape of which conform to the row of side ports 73 formed in the tubular post section 67. As such, each locking projection 79 snugly fits into the oval side ports 73 (as illustrated in Figure 8) to thereby prevent vertical shifting of the locking liner 75 within the support post 36.

[0079] More particularly as to Figure 18, each locking projection 79 has a generally cylindrical shape defined by an outwardly projecting, annular side wall 80 which terminates and is closed off by an outer end wall 81 to thereby define a blind bore 82, wherein each blind bore 82 effectively defines a locking recess for engagement by the latching mechanism 41. The locking recesses 82 are vertically spaced apart and each define a respective elevation at which the arm cap 43 may be maintained by the latching mechanism 41.

[0080] The non-locking liner 76 and the locking liner 75 are interconnected to thereby prevent displacement of the non-locking liner 76 relative thereto. In this regard, the opposite vertical side edges 84 of the locking liner 75 are provided with respective pairs of tabs 85 and 86 which generally project circumferentially relative to the arcuate shape of the liner side wall 77. It is noted that the upper tabs 85 are vertically offset relative to each other as can be seen in Figure 17, while the lower pair of tabs 86 are aligned with each other.

[0081] The support post unit 34 further is configured to define the upper and lower limits of travel for the telescoping movement of the arm rest assembly 35 relative to the support post unit 34. In this regard, the locking liner 75 is molded so as to include an upper pair of stops 88 and a lower pair of stops 89. The upper stops 88 cooperate with the arm rest support column 40 to define the downward stop location for the arm rest assembly 35. The lower stops 89 are

adapted to define the upward stop location for this arm rest assembly 35.

[0082] More particularly, each of the stops 88 and 89 is defined by an arcuate band of molded plastic 90 which bows radially inwardly and is separated from adjacent areas of the liner wall 77 along the top and bottom edges thereof by slots 91. The slots 91 permit radially outward deformation and deflection of these plastic bands 90 during installation of the arm rest assembly 35 within the hollow interior of the tubular post section 67. The function of the stops 88 and 89 is described in further detail herein with respect to the arm rest assembly 35.

[0083] During installation, the locking liner 75 is slid downwardly into the upper open end 68 of the tubular post section 67 and then shifted sidewardly so that the locking projections 79 fit into the respective side ports 73 which side ports 73 thereby prevent vertical displacement of the liner 75 after installation. Thereafter, the opposite non-locking liner 76 is fitted downwardly and then shifted sidewardly so as to be interconnected with the locking liner 75.

[0084] More particularly as to the liner 76, Figures 21-22 illustrate this liner. This liner 76 has an arcuate shape defined by the liner side wall 93. The opposite vertical side edges thereof include upper notches 95 and lower notches 96 as seen in Figure 21. The upper notches 95 are vertically offset relative to each other so as to be aligned and interfit with the respective tabs 85 on the opposite liner 75. The lower notches 96 are aligned relative to each other and interfit with the respective tabs 86. The offset provided in the upper notches 95 and tabs 85 ensures proper orientation of the liner 76 relative to the liner 75.

[0085] Further, the liner 76 includes radially arcuate upper and lower stops 98 and 99 which are formed substantially identical to and located at the same positions as the above-described stops 88 and 89. As seen in Figure 22, the lower

stops 99, like the upper stops 98, bow radially inwardly but are deflectable radially outwardly during installation of the arm assembly 35. The stops 98 serve as down stops for the arm assembly 35, while the other stops 99 serve as up stops.

[0086] Once the liners 75 and 76 are installed into the tubular post section 67, these liners 75 and 76 cover the entire inside surface of the post interior 69 and define a plastic interior face 77-1 along which the arm rest support column 40 is able to slide vertically.

[0087] Referring more particularly to the connection of the armrest assembly 35 to the post unit 34, the support column 40 (as illustrated in Figures 23-25) is formed from a molded plastic material, preferably glass filled nylon, and is adapted to slidably fit within the vertical interior of the post unit 34. The column 40 includes a main vertical body 101 which has an oval cross-sectional shape (Figure 14) which closely conforms to the oval shape defined by the inside faces of the liners 75 and 76. In particular, the column body 101 has an exterior surface 102 which is arcuate and substantially smooth except that it includes four circumferentially spaced guide channels 103. The guide channels 103 align with the various stops 88, 89, 98 and 99 of the liners 75 and 76. The guide channels 103 have a generally arcuate face which conforms to and is adapted to receive these various stops 88, 89, 98 and 99 so that when these stops are received within these channels 103, the column body 101 is still vertically slidable therealong.

[0088] The upper ends of the channels 103 terminate at end faces 104 that are defined as abrupt abutments which are adapted to abut against the upper edges of the corresponding upper stops 88 and 98. As such, during lowering of the arm rest assembly 43, these end faces 104 abut against the upper stops 88 and 98 to thereby define the downward limit of the arm rest assembly 43.

[0089] At the bottom end of each guide channel 103, bottom end walls 105 are formed which define upward facing abrupt

abutments that are adapted to abut against the lower edge of the lower stops 89 and 99 to thereby define the upper limit of travel of the arm rest assembly 43. The lower end walls 105 are formed as solid formations and are not deflectable but have inclined surfaces 106 downwardly adjacent thereto which surfaces are inclined outwardly as illustrated in Figure 24. These inclined surfaces 106 are adapted to abut against the respective stops 88, 89, 98 and 99 during downward insertion of the column body 101 into the liner assembly 37. These inclined surfaces 106 cause the various stops to deflect radially outwardly as generally indicated by reference arrows 108 and 109 in Figures 19 and 22 to provide clearance and permit insertion of the column body 101. Once installed, the stops 88, 89, 98 and 99 return to the condition illustrated in Figures 19 and 22 such that the bottom channel end walls 105 merely abut against the lowermost stops 89 and 99 and prevent removal of the column body 101 therefrom.

[0090] As such, the column body 101 is vertically slidable in telescoping relation within the posts 36. As seen in Figure 8, when the column body 101 is at its lowest extent of travel, the lower end 111 of the column body projects downwardly out of the post opening 71. However, when fully raised, the lower body end 111 is able to travel upwardly into the interior of the tubular post section 67 to the location of the lower stops 89 and 99.

[0091] Additionally, the column body 101 is hollow in that it includes an interior chamber that extends along the entire vertical length of the support column 40 which interior chamber is adapted to receive the latching mechanism 41 therein. More particularly, the upper end of the column body 101 is an enlarged hub 112 defined by an annular hub wall 113. The rear end of the hub 112 includes an upstanding pivot shaft 114, the function of which will be described in further detail hereinafter. The inner side of the hub wall 113 is formed with a rectangular notch 116 (Figures 5, 6 and 8) which opens sidewardly therethrough.

[0092] To accommodate the latching mechanism 41, the column body 101 includes an installation window 118 (Figures 5, 6 and 23) and a latch window 119 opposite to the installation window 118. The latch window 119 is generally aligned with the vertical row of the latch recesses or bores 82. The installation window 118 and latch window 119 thereby accommodate and permit installation and operation of the latching mechanism 41.

[0093] The latching mechanism 41 includes an actuator lever 121 (Figures 5, 6 and 8). Lever 121 is vertically elongated so as to fit within the hollow interior of the column body 101 as generally illustrated in Figure 8. The lever 121 is L-shaped and terminates at the upper end thereof with a hand piece 122 that projects sidewardly through the hub notch 116 as seen in Figure 8. Therefore, the hand piece 122 is accessible for manual lifting by the chair occupant to thereafter effect vertical displacement of the lever 121. The lower end of the lever 121 has a forked section 124 that terminates with a pair of spaced apart actuator legs 123 that have inclined cam surfaces 126. Therefore, upon lifting of the hand piece 122, the lever 121 is displaced vertically upwardly, which therefore actuates a cassette assembly 128 that performs the latching function.

[0094] Referring generally to Figures 5 and 6, the cassette assembly 129 includes a slidable latch 130, a biasing spring 131 and a cassette case or housing 132 which are all assembled together prior to installation within the column body 101. Referring to Figures 27-29, the slidable latch 130 (Figure 28) generally is a molded plastic block having a central body 133 formed with an end projection 134. The end projection 134 has an oval shape which corresponds to the oval shape of each stop bore 82 and therefore is slidable sidewardly into engagement therewith as illustrated in Figure 26.

[0095] The opposite sides of the central latch body 133 are formed with enlarged guide ribs 136, and a pair of actuator pins 137 projecting from the remaining two sides of the

central body 133. The end of the body 133 opposite to the projection 134 includes a blind spring bore 138.

Additionally, the guide ribs 136 include raised stops 140 which have a ramp-like face 141 to facilitate assembly.

[0096] As to the cassette housing 132, this housing 132 includes an end section 143 which supports a pair of spaced apart arms 144 to generally define a U-shape for the housing 132. The arms 144 include elongate guide channels 145 on the inside face thereof which open inwardly in opposing relation with each other and open sidewardly from the end of the housing 132 so as to slidably receive the corresponding guide ribs 136 of the latch 130 therein which thereby permits the slidable latch to be received into the housing 132.

[0097] The arms 144 each include a slot 146 which is adapted to align with and receive the latch stops 140. These slots 146 are elongate so as to permit displacement or sliding of the latch 130 within the housing 132 during operation. The above-described spring 131 is received within the spring bore 138 and abuts against the inside face of the housing end portion 143 to normally bias the latch 130 outwardly to the position illustrated in Figure 27 while also permitting inward displacement of this latch 130.

[0098] It is noted that the actuator pins 137 of the latch 130 project sidewardly from the spaces between the housing arms 144 so that they are able to abut against and cooperate with the forked section 123 of the lever 121. Referring more particularly to Figure 9, this figure illustrates the actuator pins 137 in engagement with the individual legs 124 of the forked section 123. Since the legs 124 are tapered, vertical displacement of the slide lever 121 in the upward direction causes the pins 137 to be displaced sidewardly which thereby pulls the latch 130 into the interior of the cassette housing 132 which in turn disengages the latch projection 134 from the corresponding stop bore 82. Thus, vertical displacement of the slide lever 121 disengages the latch 130 and thereby permits vertical movement of the arm rest assembly 35 so long

as the slide lever 121 is being pulled upwardly by the chair occupant. Since the latch 130 is spring biased by the spring 131, this spring 131 further functions to help return the lever 121 to its lowered position (Figure 8) since displacement of the latch 130 sidewardly helps to cam the slide member 121 downwardly.

[0099] To secure the cassette assembly 128 in its installed position (Figure 26), the cassette housing 132 also includes cantilevered fingers 148 which deflect inwardly during insertion of the cassette housing 132 through the installation window 118 and then snap outwardly to abut against the inside face 149 of the column body 101. Referring to Figure 29, the housing end portion 143 includes stepped edges 150 that abut against the outside face 102 of the column body 101 which thereby traps the thickness of the column body 101 between these stepped edges 150 and the cantilevered fingers 148.

[00100] It is noted that the installation window 118 also includes notches 152 (Figure 23) which are adapted to permit passage of the latch actuator pins 137 through the window 118 during installation. In this manner, the cassette assembly 128 is first assembled by inserting the spring 131 into the cassette housing 132 and then snapping the slidable latch 130 into the housing 132. This cassette assembly 128 is then snap fitted into the installation window 118 and held in place by the spring fingers 148. The latch 130 is freely movable horizontally with the projection 134 thereof projecting outwardly of the column body 101 through the latch window 119 as seen in Figure 26. Hence, lifting of the lever 121 causes the latch 130 to move sidewardly out of engagement for repositioning of the arm rest assembly 35.

[00101] Furthermore, in this manner, the slide lever 121 is installed merely by sliding same downwardly into the column body 101 and then is retained in place once the cassette assembly 128 is snapped into position.

[00102] Turning next to the connection of the arm cap 43 to the column 40, the column hub 112 is formed with a first

fastener bore 156 (Figure 23) in the front section thereof and a second fastener bore 157 in the upward-projecting pivot shaft 114.

[00103] Generally as to Figures 6 and 7, the plates 46-49 are provided to permit the arm cap 43 (Figure 5) to move in multiple adjustment directions. In particular, the pivot plate 46 provides for angular displacement of the arm cap 43 generally in the direction of reference arrow 160 (Figures 6 and 7). The slide-plate 47 permits adjustment of the arm cap 43 in the direction of reference arrow 161 while the top subcap plate permits adjustment in the direction of arrow 162. The movement of these various plates 46, 47, and 48 is all permitted independently of each other in that the displacement of any one of these plates in the direction of any one of its respective adjustment directions does not require displacement in the other remaining directions such that any combination of angular, longitudinal front-to-back and transverse, side-to-side movement is permitted.

[00104] More particularly as to these structural components, the pivot plate 46 is adapted for angular displacement about the pivot shaft 114 that projects upwardly from the column hub 114. The pivot plate 46 includes a shaft bore 163 which extends vertically through the back end of the pivot plate 46 and receives the shaft 114. Initially during installation, the plate 46 is merely seated onto the shaft.

[00105] To control angular displacement of the pivot plate 46, this plate 46 includes an arcuate guide slot 164 which extends over the fastener bore 156. A cylindrical pivot bearing 166 is provided which has a lower shaft section 167 and enlarged head 168 as seen in Figure 6. The shaft section 167 fits into the slot 164, and the bearing head 168 has a diameter larger than the slot 164 so as to effectively secure the pivot plate 46 in place and prevent removal from the column hub 112. A fastener 169 is inserted through the bearing 166 and threadedly engaged with the fastener bore 156 as seen in Figure 30. During pivoting of the plate 46, the

bearing 166 remains stationary while the slot 164 is displaced relative thereto. The opposite ends of the slot 164 define stop surfaces which abut against the bearing 166 to define the maximum limits of angular displacement of this pivot plate 46.

[00106] Adjacent to the slot 164, a detent cavity 171 is provided and an elastomeric pivot detent 172 is provided in this cavity. The detent 172 is illustrated in further detail in Figure 31 and includes a generally U-shaped sidewall 173 and a deflectable front wall 174. The front wall 174 in the preferred embodiment has three bearing seats 176 separated and defined by projecting portions 177. The projecting portions 177 effectively work as cams in cooperation with the outer surface of the bearing 176 so as to effect inward deflection of the front wall 174 away from the bearing 166 during angular displacement of the pivot plate.

[00107] The pivot detent 172 is formed of an elastomeric deformable material and preferably is formed of urethane which allows for deflection of the front wall 174 while also resisting angular displacement of the pivot plate 46. While resisting pivoting, sufficient manual twisting of the arm cap 43 by the occupant will eventually reach a pivoting force which overcomes the normal deformation capacity of the urethane material. Hence, the detent 172 defines the threshold or capacity above which the arm cap 43 is displaceable angularly and below which the arm cap 43 is maintained in its angular position by the resiliency of this detent 172. The remainder of the arm cap assembly is supported on this pivot plate 46 such that pivoting movement of this pivot plate 46 allows the rest of the arm cap assembly to simply move angularly in unison therewith.

[00108] To further secure the remainder of the components onto this plate 46, the plate 46 also includes an upstanding post 180 having a vertical fastener bore 181 therein.

[00109] To facilitate longitudinal sliding of the arm cap 43 in the front-to-back direction, the slide plate 47 is mounted upon the pivot plate 46. Referring to Figures 32 and 35, the

pivot plate 47 includes a central channel 183 and a longitudinal slot 184 which defines the path along which the slide plate is movable. The channel 183 includes side walls 185 along the longitudinal length thereof which side walls 185 include depressions 186 in longitudinally spaced relation. These recesses 186 define the various stop positions for the arm cap 43 when moved in this longitudinal direction.

[00110] The slide plate 47 is positioned onto the pivot plate 46 during assembly, and when so positioned, the central slot 184 receives the projecting post 180 therein along with the upper most section 187 of the pivot shaft 114 as best seen in Figure 30. The post 180 and shaft section 187 therefore guide longitudinal sliding of the plate 47.

[00111] To secure the slide plate 47 in place and also restrain longitudinal movement thereof, the slide detent 189 is fitted into the guide channel 183 as illustrated in Figure 35. The slide detent 189 (as illustrated in Figure 32) includes rectangular connector sections 190 at the opposite ends thereof which include bores 191 extending vertically therethrough. These connector sections 190 are joined together by deflectable sidewalls 192 which are separated from each other by a rectangular open space 193 disposed therebetween. The slide detent 189 also is formed of elastomeric material and preferably is formed of urethane. The sidewalls 192 include projecting cams 195 which are configured to engage the channel recesses 186 and the channel sidewalls 185. The slide detent 189 preferably is formed of an acetyl copolymer having some rigidity while also permitting resilient deflection of the sidewalls 192 thereof.

[00112] Referring to Figures 30 and 35, the slide detent 189 is fitted into the channel 183 with the cams 195 seated within any one of the sidewall recesses 186. The bores 191 are then aligned with the fastener bores 157 and 181 wherein fasteners 196 are then threadedly engaged therewith such that the slide detent 189 remains stationary relative to the pivot plate 46 and secures the intermediate slide plate 47 thereon. Hence,

the slide plate 46 is slidable longitudinally relative to the pivot plate 46 to thereby permit longitudinal adjustment of the position of the arm cap 43 relative to the support column 30.

[00113] To secure the remaining components to the slide plate 47, this plate 47 also includes raised posts 198 which project upwardly and include vertical fastener bores 199 therein.

[00114] Referring to Figures 30 and 36, the translatable subcap plate 48 is adapted for mounting to the intermediate slide plate 47. This translatable subcap plate 48 is movable sidewardly or transversely in the direction of reference arrows 162. More particularly, the plate 48 includes transverse guide slots 201 and 202 at the opposite front and rear ends thereof. These guide slots 201 and 202 receive the fastener posts 198 vertically therethrough to thereby govern the transverse sliding of the subcap plate 48. Also, the opposite ends of the slots 201 and 202 define the limits of sideward travel for the arm cap 43. Further, a transverse guide rib 204 is provided adjacent to, and parallel with the guide slots 201 and 202; this will be described in detail in later sections.

[00115] More particularly, the retainer plate 49 then mounts on top of the top plate 48 to secure all of the components together. Particularly, the opposite ends of the retainer plate 49 include fastener bores 206 that align with the bores 199 on the post 198 which project through the top plate 48. When the retainer plate 49 is seated onto the top plate 47, fasteners 207 are then threadedly engaged therethrough as illustrated in Figure 30. This prevents removal of the top plate 47, though top plate 47 is still slidable transversely relative to both the slide plate 47 and the retainer plate 49.

[00116] To guide movement of the top plate 48, the retainer plate 49 also includes a guide slot 208 on each end of the bottom thereof into which the corresponding guide ribs 204 are

received so that the transverse movement of the subcap plate 48 is essentially perpendicular to the slide plate 47.

[00117] To maintain the subcap plate 48 in a selected transverse position, a detent arrangement also is provided between the retainer plate 49 and the stop plate 48. More particularly, the retainer plate 49 on the bottom includes a pair of L-shaped locator ribs 209 which project downwardly and align with a detent cavity 210 formed in the plate 48.

[00118] Referring to Figures 36, 37 and 33, this detent arrangement includes a transverse detent 212 which is adapted to fit on the locator ribs 209. More particularly, the transverse detent 212 is formed similar to the above described detents in that it is formed as a ring of elastomeric material, preferably urethane. This detent 212 includes a U-shaped sidewall 213 and a deflectable front wall 214. The front wall 214 further includes an outwardly projecting cam 215. The detent sidewalls 213 are adapted to fit around the locator ribs 209 with the detent front wall 214 extending between the free ends of the locator ribs.

[00119] When the retainer plate 49 is mounted in position, this detent 212 fits within the corresponding cavity 210 as illustrated in Figure 36. The cavity 210 is a shallow depression wherein one sidewall 217 thereof includes a plurality and preferably three depressions 218. When the detent 212 is fitted within this cavity 210, the cam 215 fits into a selected one of these depressions 218 depending on the lateral position of the transverse plate 48 relative to the adjacent plates 47 and 49. This cam 215 fits within a respective depression 218 and maintains the interconnected arm cap 43 in a corresponding lateral position until such time as an adjustment force is applied to the arm cap 43 by an occupant that overcomes the threshold at which the detent front wall 214 then deflects inwardly and permits lateral sliding of the plate 48. Therefore, the detent 212 normally maintains the arm cap 43 in a selected position and resists lateral movement thereof but still permits selected

displacement in response to a sufficient adjustment force being applied to the arm cap 43.

[00120] The top plate 48 also includes a front hook 220 on the front edge thereof and an additional fastener bore 221 (Figure 36) which receives a fastener 222 (Figure 30) to secure the arm cap 43 in place onto the subcap plate 48.

[00121] In view of the foregoing, assembly of the arm cap assembly 35 is accomplished by first positioning the pivot plate 46 onto the shaft 114, locating the bearing 166 in the appropriate slot 164 and then fastening the bearing 166 in place by the fastener 169. The plate 46 thereby is non-removably connected by the support column 40.

[00122] Thereafter, the intermediate slide plate 47 is positioned with its respective center slot 184 aligned with and receiving the upwardly projecting post 180 and shaft projection 157 therethrough. Then the slide detent 189 is positioned with the fastener holes 191 thereof aligned with the respective fastener bores 157 and 181 so that the fasteners 196 may be secured with these bores. As such, the intermediate slide plate 47 is non-removably fixed to the pivot plate 46 but is still slidable relative thereto in the direction of reference arrow 161.

[00123] Then, the translatable top plate 48 is positioned onto the slide plate 47 with the post 198 projecting through the slots 201 and 202. The retainer plate 49 is assembled with the detent 212 located on the bottom thereof and then positioned over the plate 48. The guide slots 208 and the retainer plate 49 are fitted onto the upstanding guide ribs 204 which therefore aligns the bores 206 on the retainer plate 49 with the corresponding fastener bores 199 located on the post 198. Fasteners 207 are screwed into place which prevents removal of the top plate 48 from the lower slide plate 47 while still permitting transverse sliding movement thereof.

[00124] Finally, the top cap is hooked onto the front hook 220 and secured in place to complete the assembly of the arm cap arrangement. Once the full arm rest assembly 35 is

assembled together, it is installed by inserting the support column 40 downwardly into the support tube 36.

[00125] With the foregoing arrangement, the arm cap 43 may be readily adjusted with respect to any of its elevation, angular position, longitudinal position and transverse position.

[00126] Although a particular preferred embodiment of the invention has been disclosed in detail for illustrative purposes, it will be recognized that variations or modifications of the disclosed apparatus, including the rearrangement of parts, lie within the scope of the present invention.

What is claimed is:

1. A chair including a height-adjustment assembly having a body supporting member which provides support to a chair occupant, said height adjustment assembly comprising:

a support post projecting from said chair, said support post including a post wall defining a hollow interior thereof, said post wall including side cavities disposed in longitudinally spaced relation, which said side cavities open sidewardly into said hollow interior;

a liner assembly comprising first and second liner sections which are longitudinally elongate and have a generally U-shaped cross-section wherein the liner sections are disposed in opposite orientations so as to open sidewardly toward each other in an interconnected, edge-to-edge relationship, said interconnected first and second liners having a shape which corresponds to an interior shape of said support post so as to be fitted into said hollow interior in close fitting relation with said post wall, said first and second liner sections being formed of a reduced friction liner material, said first liner section including longitudinally spaced projections along one side thereof wherein said first liner section is configured to fit individually into said hollow interior with said projections fitting into said side cavities such that said first liner section is disposed in a fixed position within said hollow interior, said second liner section adapted to fit into said hollow interior separate from said first liner section wherein said first and second liner sections have cooperating interconnection parts which prevent said second liner section being removed from said hollow interior once said first liner section is disposed in position, said liner assembly further including longitudinally spaced locking recesses; and

a slidable column assembly which supports said body supporting member on an exterior portion thereof, said column assembly including an elongate column that slidably fits

within the hollow interior of said support post and is surrounded by said liner assembly so as to be slidably supported and movable along said reduced friction liner material, said column assembly including a lock assembly having a lock unit which is removably engagable with said locking recesses to define a releasably fixed position for said column assembly.

2. The chair according to Claim 1, wherein said first and second liner sections are fitted one at a time into said hollow interior of said support column.

3. The chair according to Claim 2, wherein said interconnected edges of said first and second liner sections include cooperating tabs and recesses which prevent longitudinal displacement of each of said first and second liner sections relative to the other thereof.

4. The chair according to Claim 3, wherein said tabs and recesses on one side of said liner sections are longitudinally offset relative to said tabs and recesses on the other side of said first and second liner sections to define a correct orientation for said first and second liner sections relative to each other when installed within said support column.

5. The chair according to Claim 1, wherein said first and second liner sections are each installed within said support column by inward insertion of said first and second liner sections one at a time and then sideward displacement of each said first and second liner section into abutting, facing relation with an opposing interior surface of said column wall.

6. A chair including a telescoping position adjustment mechanism comprising:

a support post and a support column slidable into a hollow interior of said support post wherein one of said post and said column is supported on said chair and the other of said post and said column telescopingly extends therefrom, said support post including a liner unit disposed within said hollow interior thereof which lines an inside surface of a post wall to define a reduced friction surface for facilitating sliding movement of said support column, said liner including guide projections which align with and slidably fit into one or more guide grooves which extend longitudinally along said support column and open outwardly toward said liner, each said guide groove including one or more limit stops that are adapted to abut against said guide projection corresponding thereto, each said guide projection being resiliently deflectable from an initial projecting position pressed into said guide groove and an outwardly deflected position, and each said limit stop defining a longitudinally facing abutment surface within said guide groove which is adapted to abut against a side edge of said respective guide projection on the liner unit, said guide projections on said liner unit being resiliently deflectable to said deflected position so as to permit passage of one of said limit stops on said post unit in an insertion direction as said column is inserted in said post, and returning to said initial projecting position to limit travel as said stop element moves up to and abuts against said guide projection.

7. The chair according to Claim 6, wherein said guide channel includes abutment surfaces defined by said limit stops which face in opposite directions at opposite ends of said guide channel to define first and second limits of travel for the relative movement between said support post and said support column.

8. The chair according to Claim 7, wherein said guide projections on said support column are defined by arcuate,

bowed sections of said liner unit, said bowed sections bowing radially inwardly so as to normally be in the initial projecting position while being resiliently deflectable to the deflected position.

9. The chair according to Claim 8, wherein said liner unit is defined by a thin-walled plastic material with pairs of said guide projections being longitudinally spaced apart from each other and cooperating with opposing said abutment surfaces within said guide groove of said support column to define the upper and lower limits of relative travel between said support post and said support column.

10. The chair according to Claim 6, wherein said stops are arcuate and bowed radially inwardly so as to closely fit within said guide groove and slide therealong during relative movement between said support post and said support column.

11. A chair comprising a telescoping position adjustment assembly which includes a body supporting surface thereon, said position adjustment assembly comprising:

a hollow support post having a post wall with a plurality of longitudinally spaced locking recesses;

a support column which is slidably insertable within said hollow interior of said support post, said support column comprising a column body having an exterior surface which is disposed closely adjacent to an interior surface of said post wall,

said column body including a chamber extending therethrough which includes an installation window on one side thereof and a latch window on another side thereof wherein said latch window is disposed closely adjacent to and moves over said latch recesses defined in said post wall; and

a locking mechanism carried by said column body and releasably engagable with said latch recesses to releasably fix the position of said column body relative to said post

wall and define the position of said body supporting surface, said locking mechanism comprising a cassette assembly which snap fits within said chamber through said installation window, said cassette assembly including a cassette housing with snap locking connector parts which snap-fittingly engage said column body to fix said cassette housing within said chamber, said cassette housing including a resiliently-biased slidable latch which is movable sidewardly within said housing and projectable out of said latch window for releasable engagement with a respective one of said latch recesses, said locking mechanism further including a manual actuator which is engagable with said slidable latch to effect releasing of said latch from said latch recesses.

12. The chair according to Claim 11, wherein said cassette assembly is pre-assembled with said slidable latch snap-fittingly restrained within said cassette housing prior to mounting within said chamber of said column body.

13. The chair according to Claim 12, wherein a resilient biasing member is disposed within said cassette assembly between said cassette housing and said slidable latch.

14. The chair according to Claim 11, wherein said latch member comprises an elongate lever extending longitudinally through a hollow interior of said column body, said latch lever having an engagement end disposed adjacent to said cassette assembly wherein said cassette assembly engages said engagement end and prevents removal of said latch lever after said cassette assembly is snapped into said column body.

15. An adjustable support mechanism having a movable body supporting surface comprising:

a fixed support body and a movable support body movably interconnected with said fixed body wherein said body support surface is defined on said movable support body and the

position thereof is defined by the relative position of said movable support body, said fixed and movable support bodies including a detent arrangement disposed therebetween to maintain said movable support body in one of a plurality of adjusted positions, said detent arrangement comprising a resiliently deflectable detent ring having a deflectable side wall with an open space disposed adjacent thereto to permit inward deflection of said side wall, said detent arrangement comprising a plurality of first connector parts which are one of a recessed seat or a projection which fits into said seat, and a second connector part which is the other of said seat and said projection, said deflectable side wall including either said first or said second connector parts formed therein with the other of said first and second connector parts being disposed fixedly adjacent thereto wherein the cooperation of said first and second connector parts maintains said movable body in one of said adjustment positions and displacement of said movable body effects deflection of said detent side wall to permit displacement of said movable body to another of said adjustment positions.

16. The detent arrangement according to Claim 15, wherein said detent ring comprises an elastomeric material wherein said side wall is elongate and resiliently deflectable.

17. The detent arrangement according to Claim 16, wherein said deflectable side wall is resiliently joined to a fixed side wall which is fixedly engaged with one of said movable and fixed support bodies.

18. The detent arrangement according to Claim 15, wherein said movable support body is rotatable about a pivot axis relative to said fixed support body.

19. The detent arrangement according to Claim 15, wherein said movable support body is movable longitudinally along an axial path relative to said fixed support body.

20. An armrest assembly comprising:
a support post having a hub thereon;
a pivot plate which is pivotally connected to said hub so as to pivot about a substantially vertical pivot axis;
an intermediate slide plate slidably connected to said pivot plate so as to move along a first longitudinal path;
a second slide plate slidably fixed to said first slide plate so as to be slidable along a longitudinal path oriented transverse to said first longitudinal path; and
an armrest mounted to said second slide plate for supporting an arm of a user.

21. The armrest assembly according to Claim 20, wherein a detent arrangement is provided between at least one of said pivot plate and said first slide plate, and said first slide plate and said second slide plate.

22. The armrest assembly according to Claim 21, wherein said pivot plate defines an angular position for said armrest.

23. The armrest assembly according to Claim 21, wherein said first slide plate defines a longitudinal position of said armrest in a front-to-back direction.

24. The armrest assembly according to Claim 21, wherein said second slide plate defines the relative position of the armrest in a side-to-side direction.

25. A chair including an armrest assembly comprising:
a seat base including a frame member;
an upwardly projecting armrest having a support post which projects downwardly and is engagable with said frame

member, said support post and said frame member being engagable by a bayonet connection defined therebetween, one of said frame member and said support post including a mounting socket having an interior surface which tapers inwardly into said socket, said bayonet connection further including a connector bayonet on the other of said frame member and said support post which has a tapered shape and fits into said mounting socket, said bayonet connection further including a drawing member which engages between said mounting socket and said connector bayonet to draw said bayonet into said mounting socket with said cooperating tapers of said connector bayonet and said mounting socket preventing play therebetween.

26. The chair according to Claim 25, wherein said drawing member comprises a fastener which engages an end wall at the inner end of said mounting socket and engages said connector bayonet to draw said connector bayonet axially inward into said mounting socket.

27. The chair according to Claim 26, wherein an inner end of said connector bayonet includes a blind bore which receives said fastener therein wherein manipulation of said fastener effects said drawing of said connector bayonet inwardly into said socket.

28. The chair according to Claim 27, wherein said fastener is threadedly engaged with said blind bore wherein rotation of said fastener draws said bayonet into said socket.

29. The chair according to Claim 25, wherein said socket and said bayonet have cooperating I-shaped profiles which are tapered and tight-fittingly support said support post on said frame member.

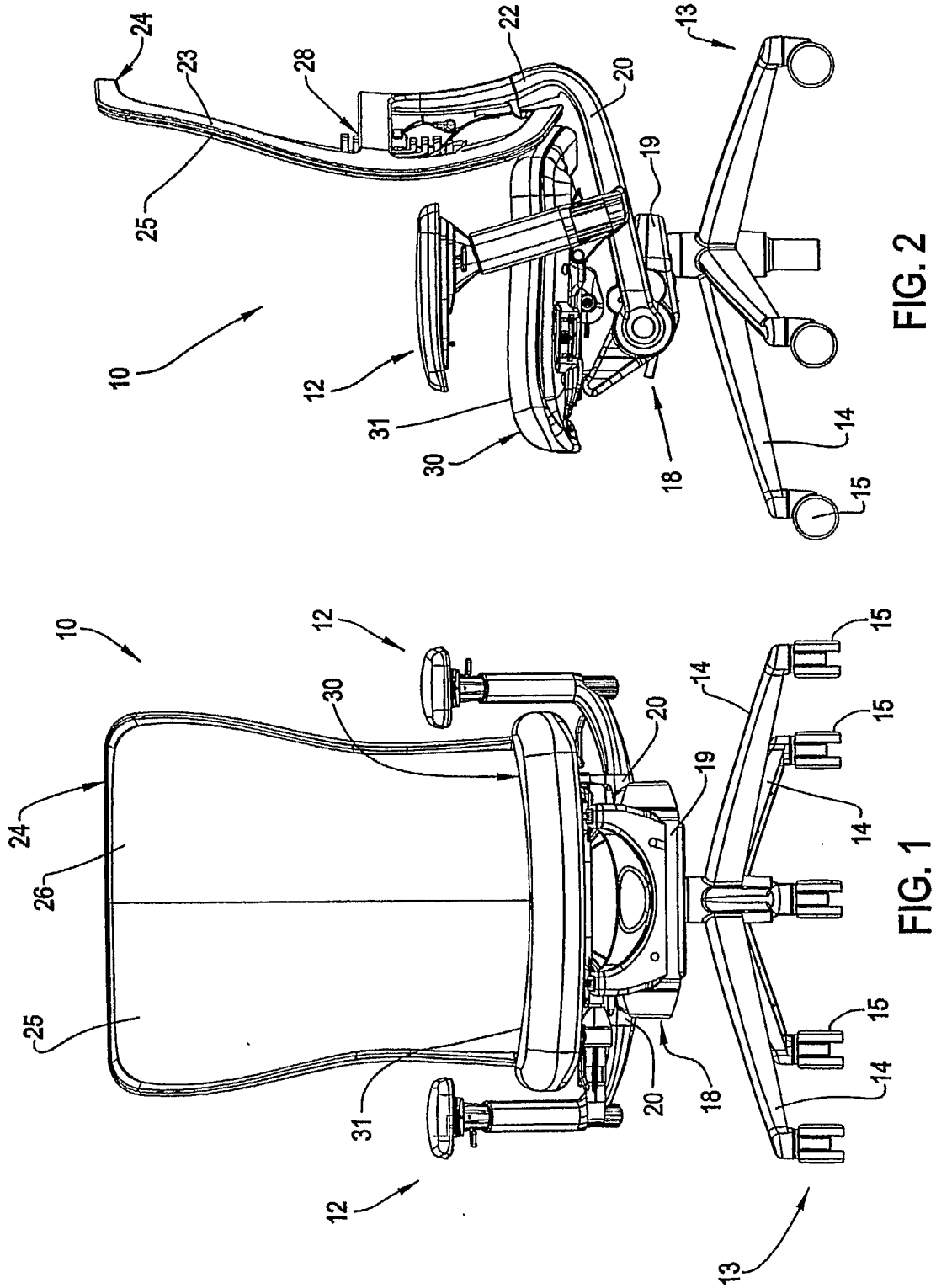
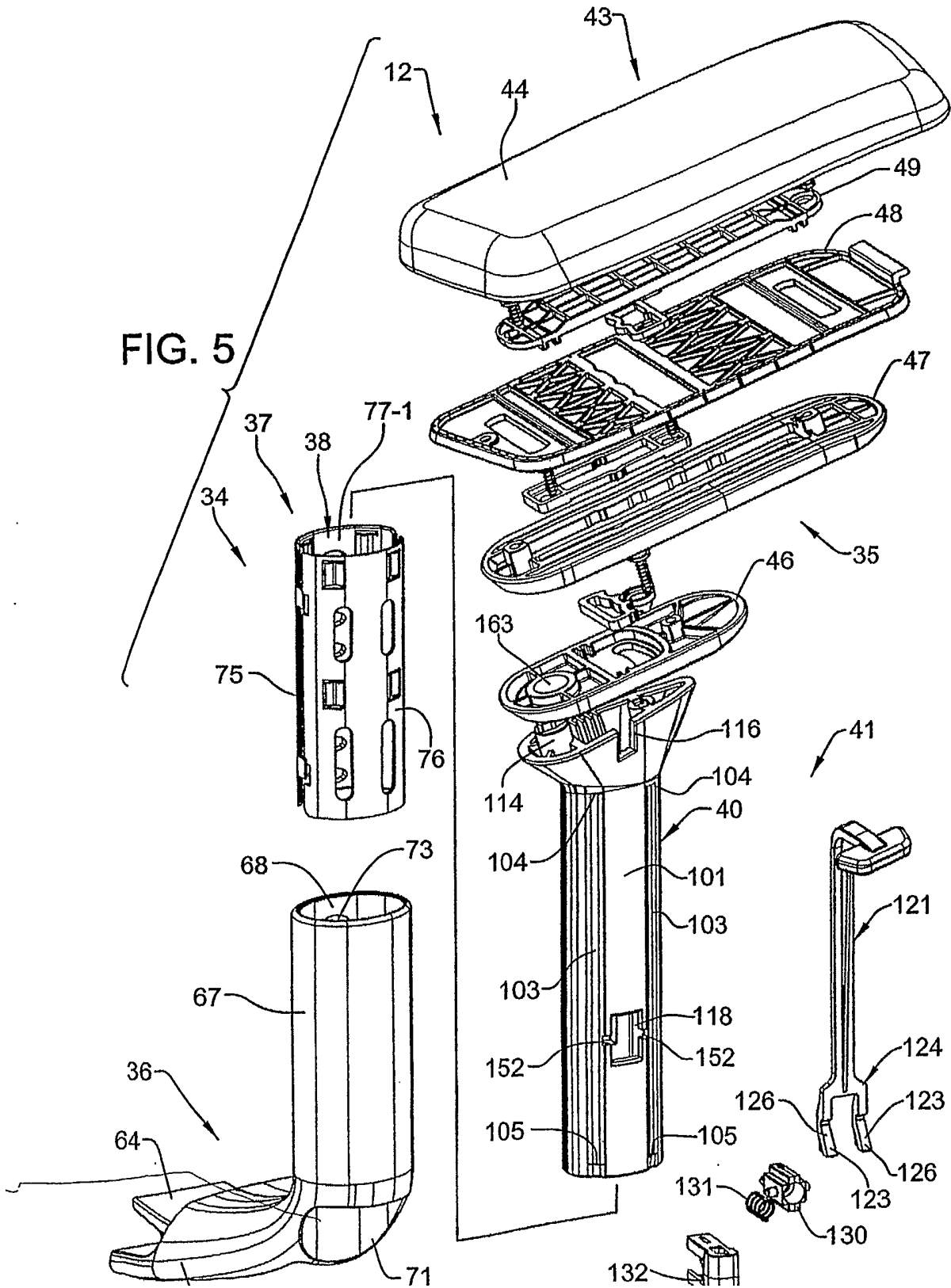

FIG. 2

FIG. 1

FIG. 5



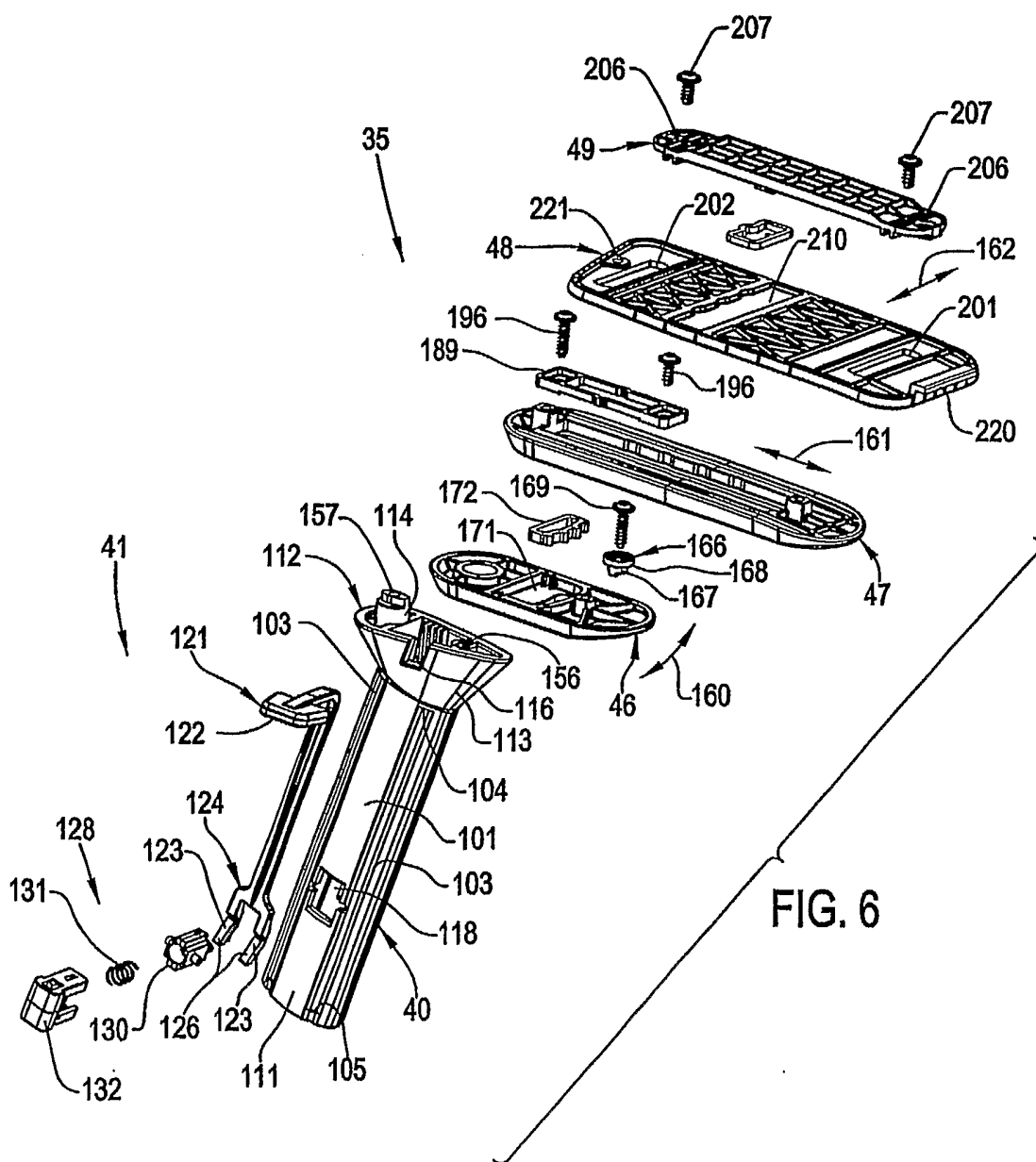

FIG. 6

5/21

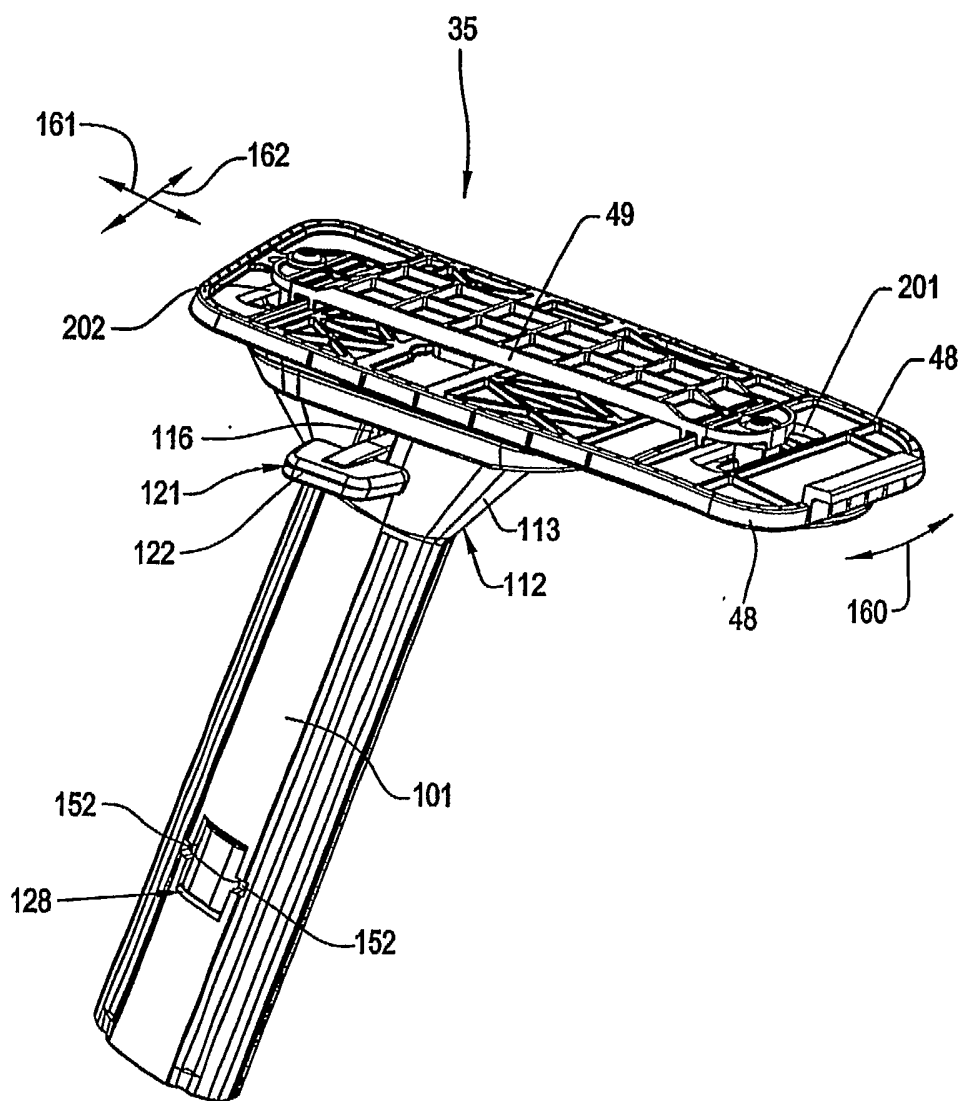

FIG. 7

6/21

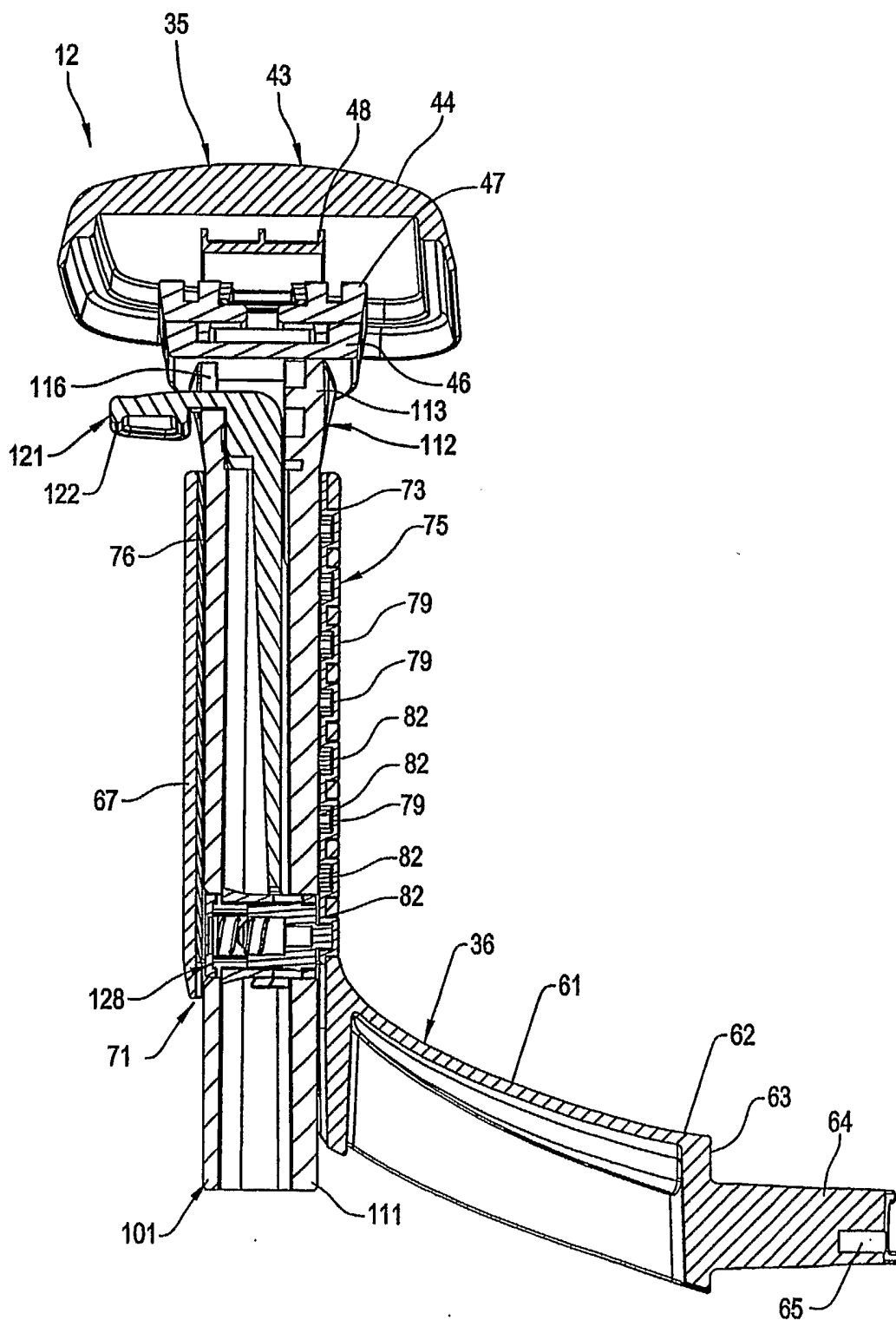

FIG. 8

SUBSTITUTE SHEET (RULE 26)

7/21

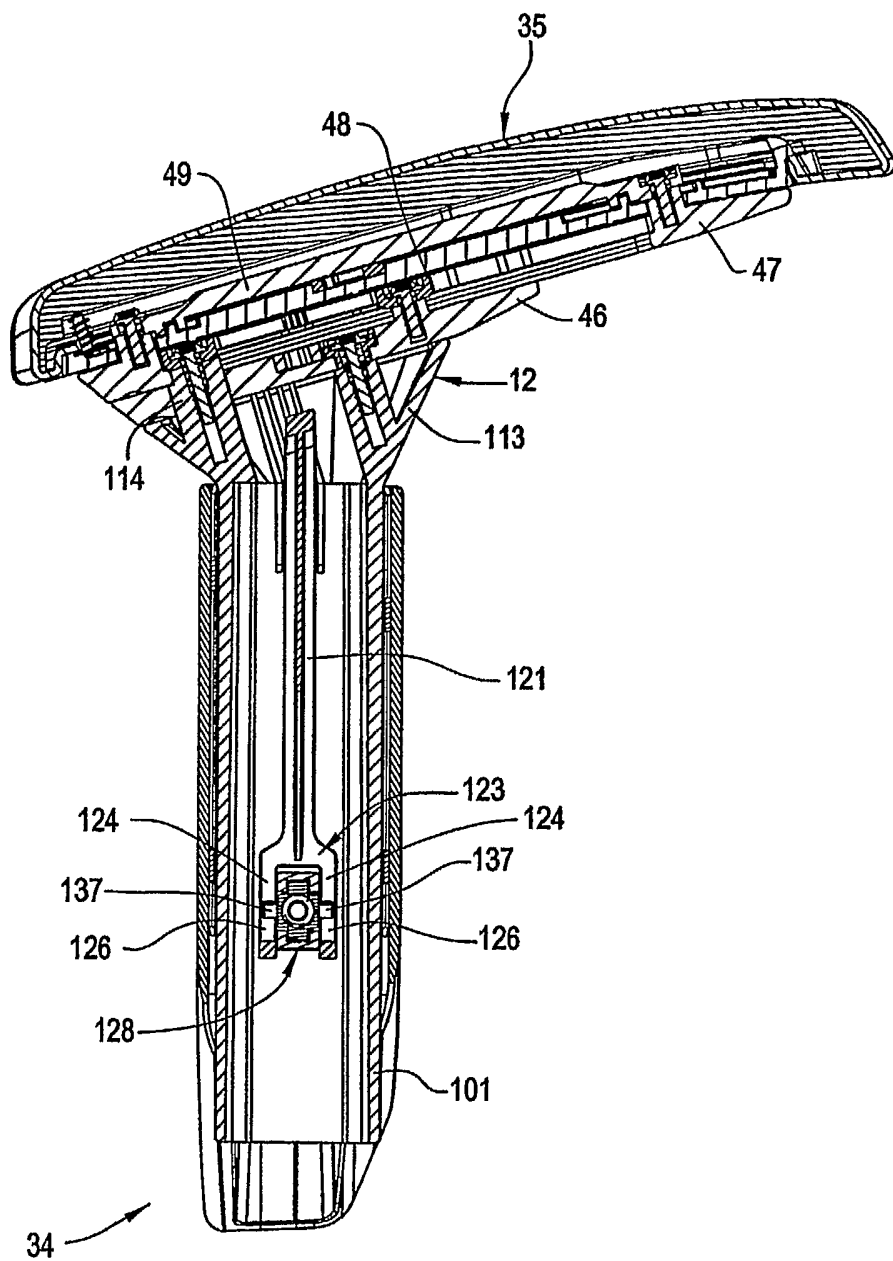

FIG. 9

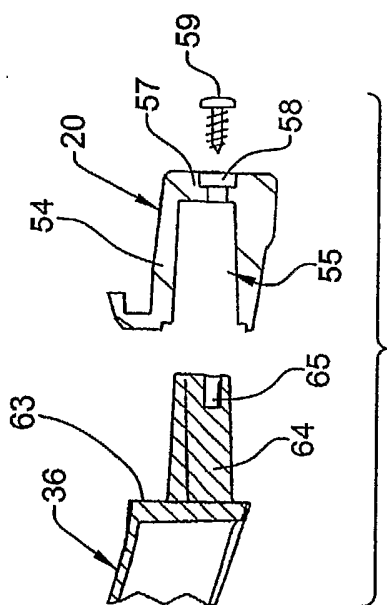

FIG. 11

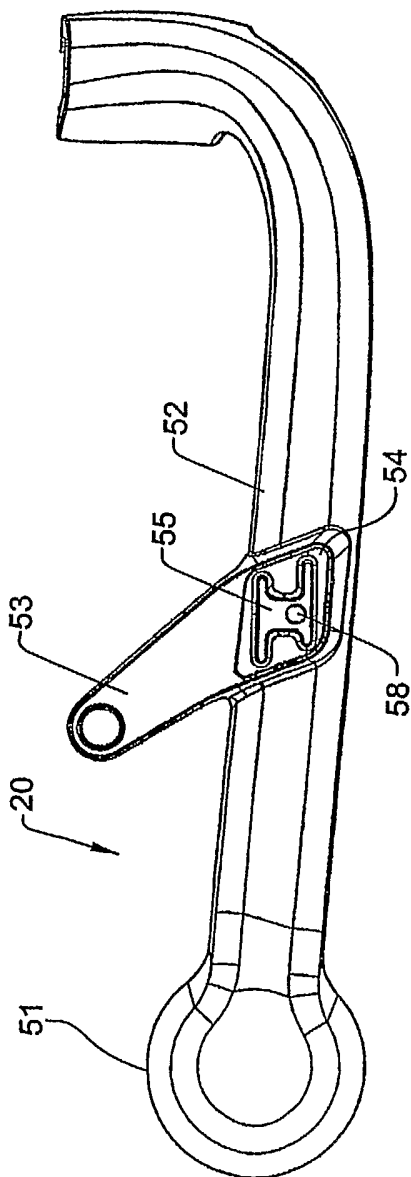

FIG. 10

9/21

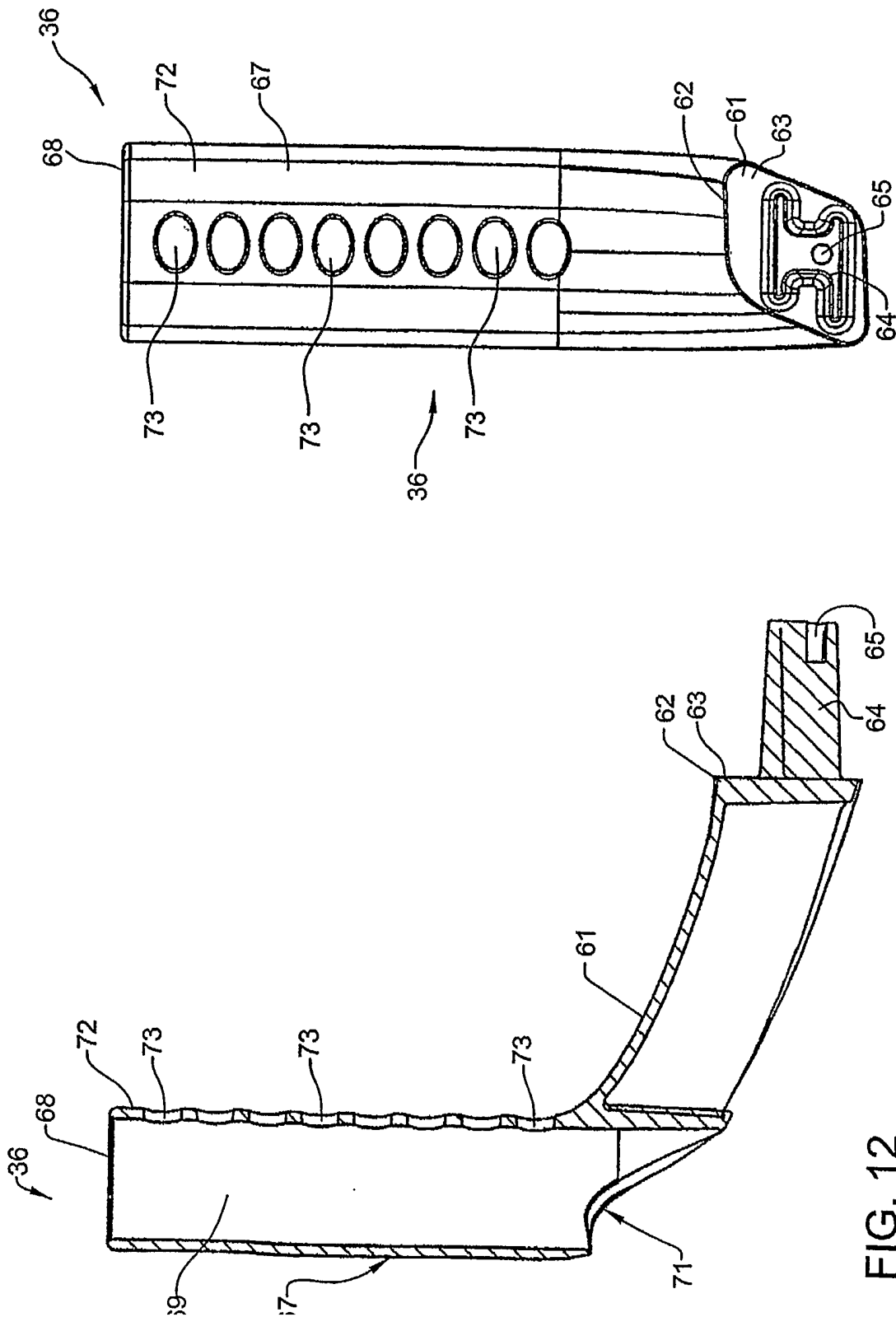

FIG. 13

FIG. 12

SUBSTITUTE SHEET (RULE 26)

10/21

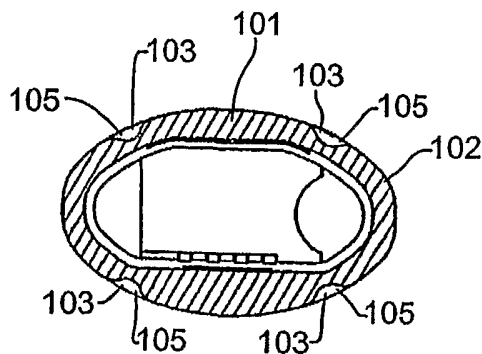

FIG. 14

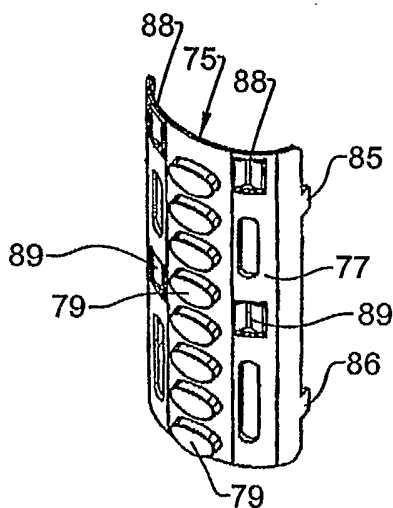

FIG. 15

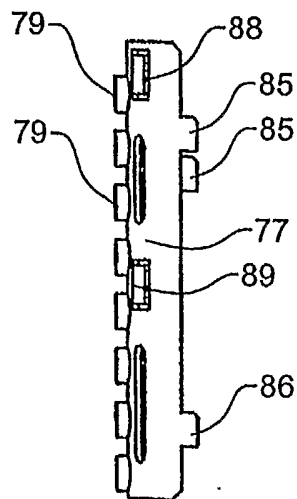
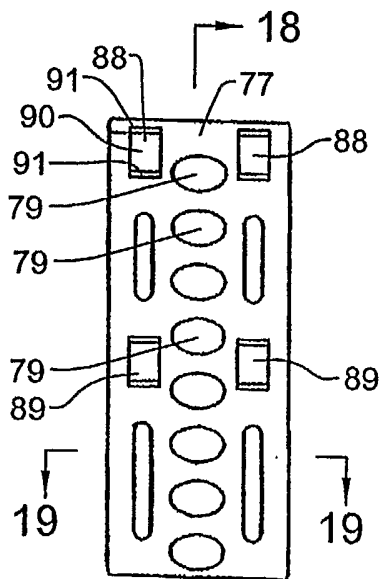

FIG. 17

11/21

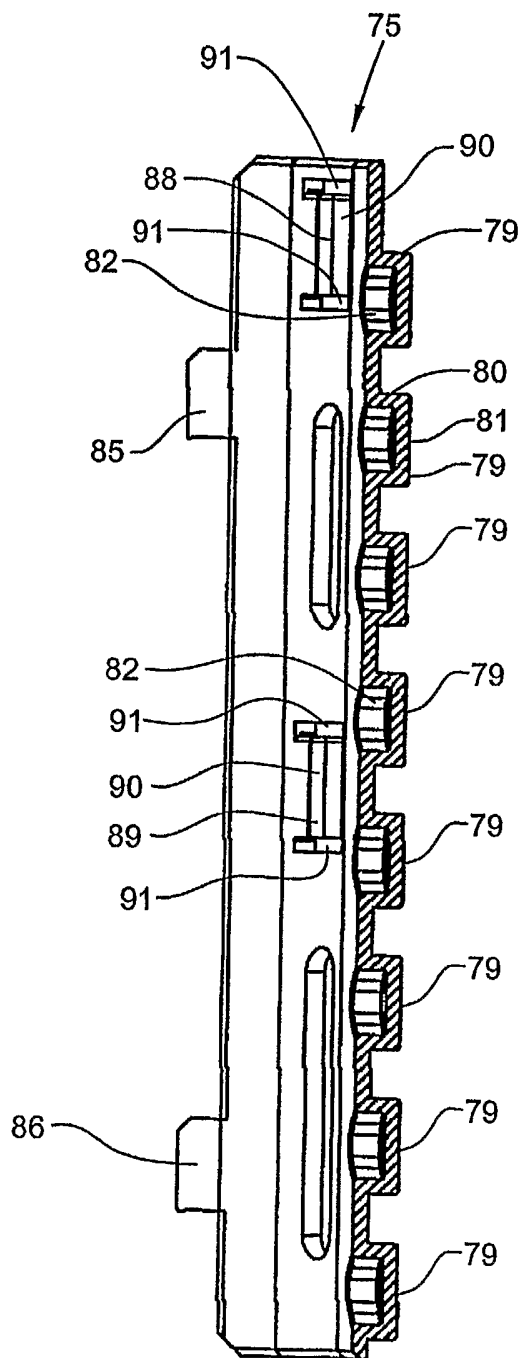

FIG. 18

SUBSTITUTE SHEET (RULE 26)

12/21

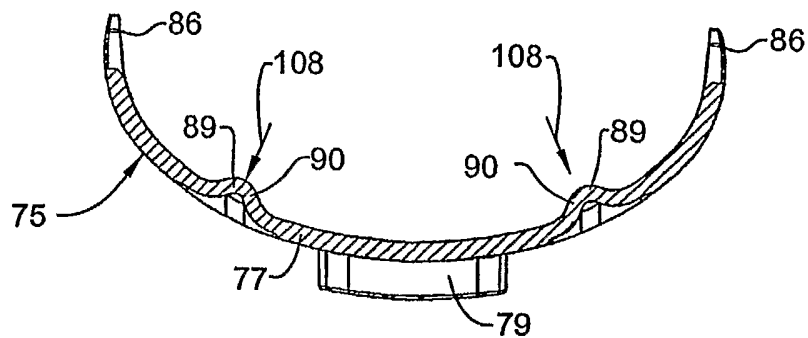

FIG. 19

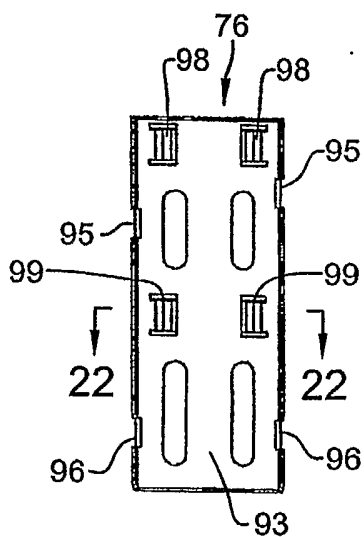

FIG. 21

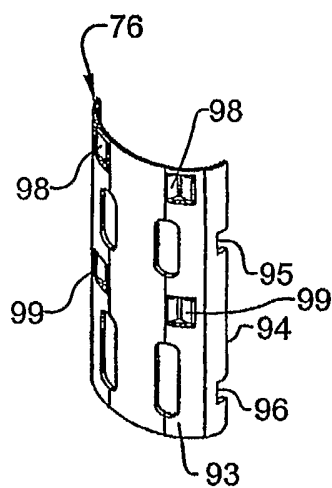
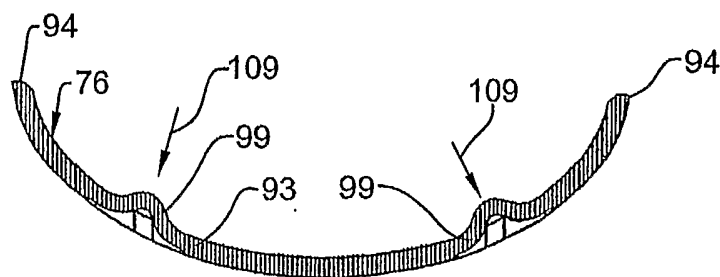

FIG. 20



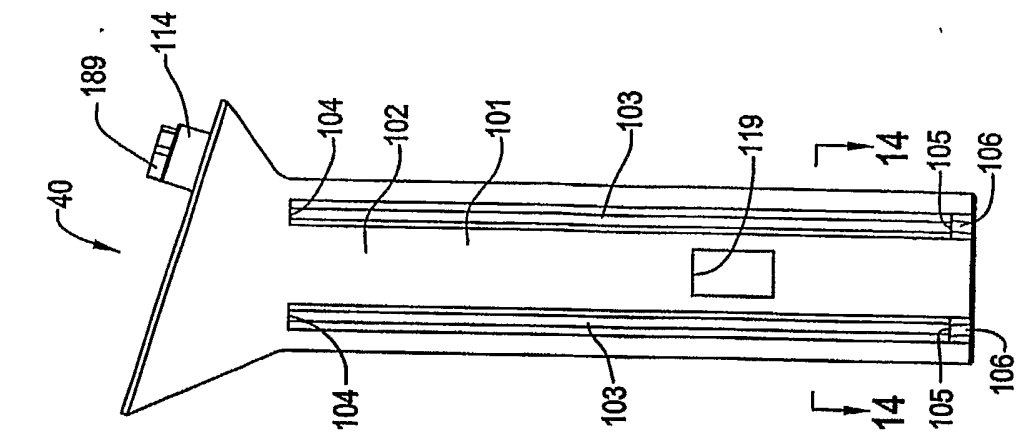

FIG. 25

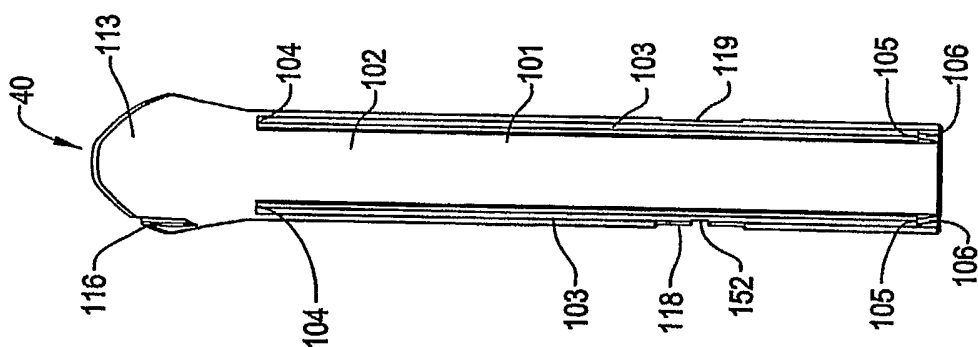

FIG. 24

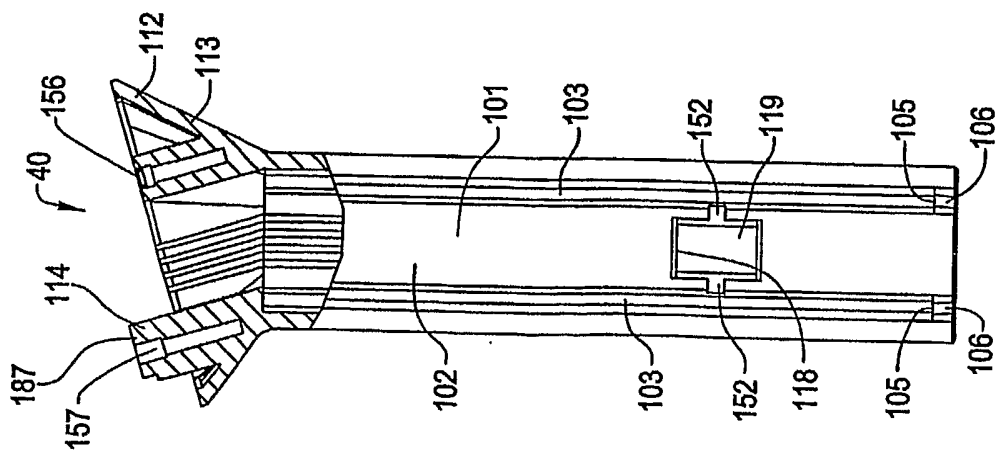

FIG. 23

14/21

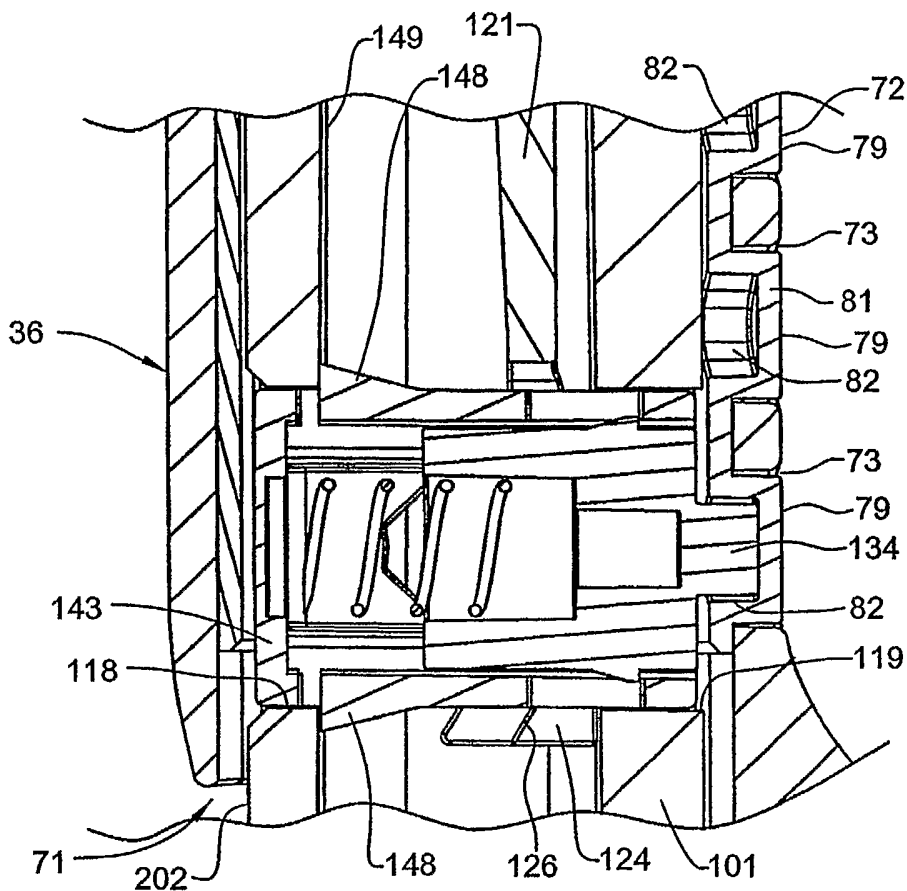
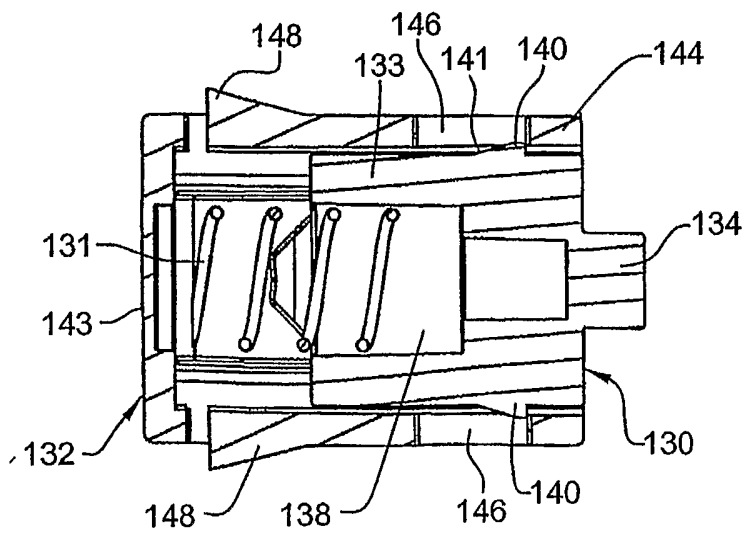

FIG. 26



15/21

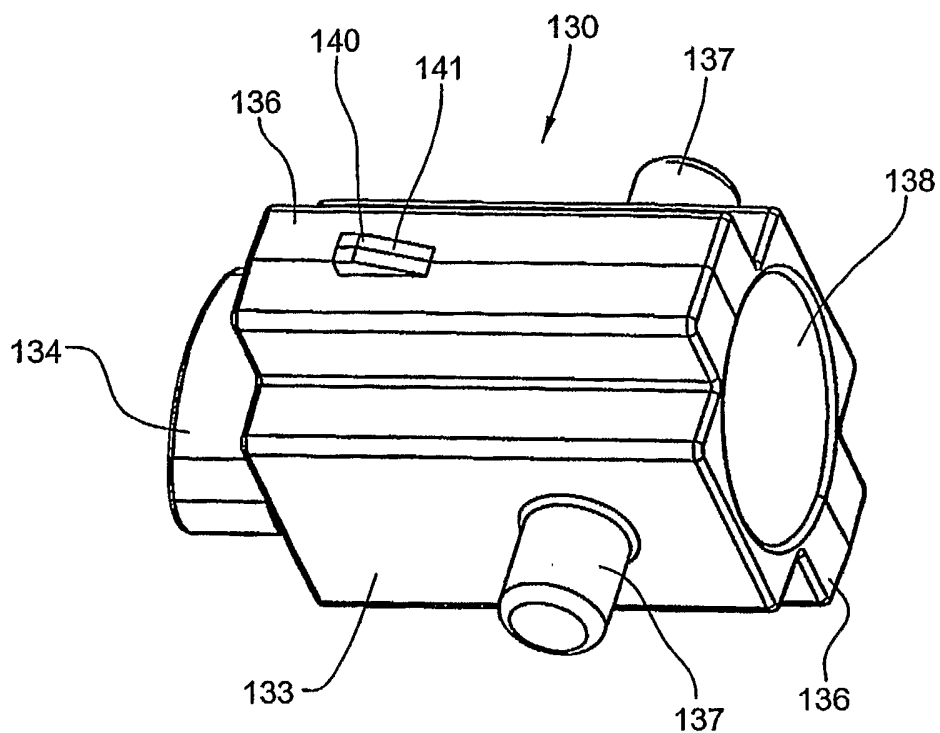
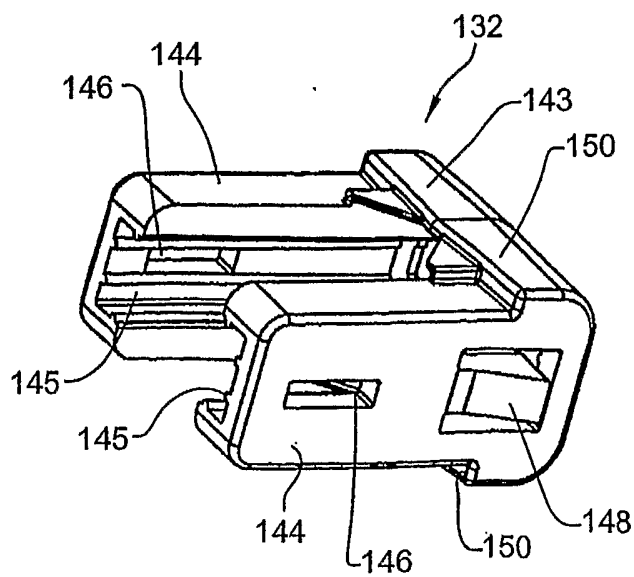

FIG. 28



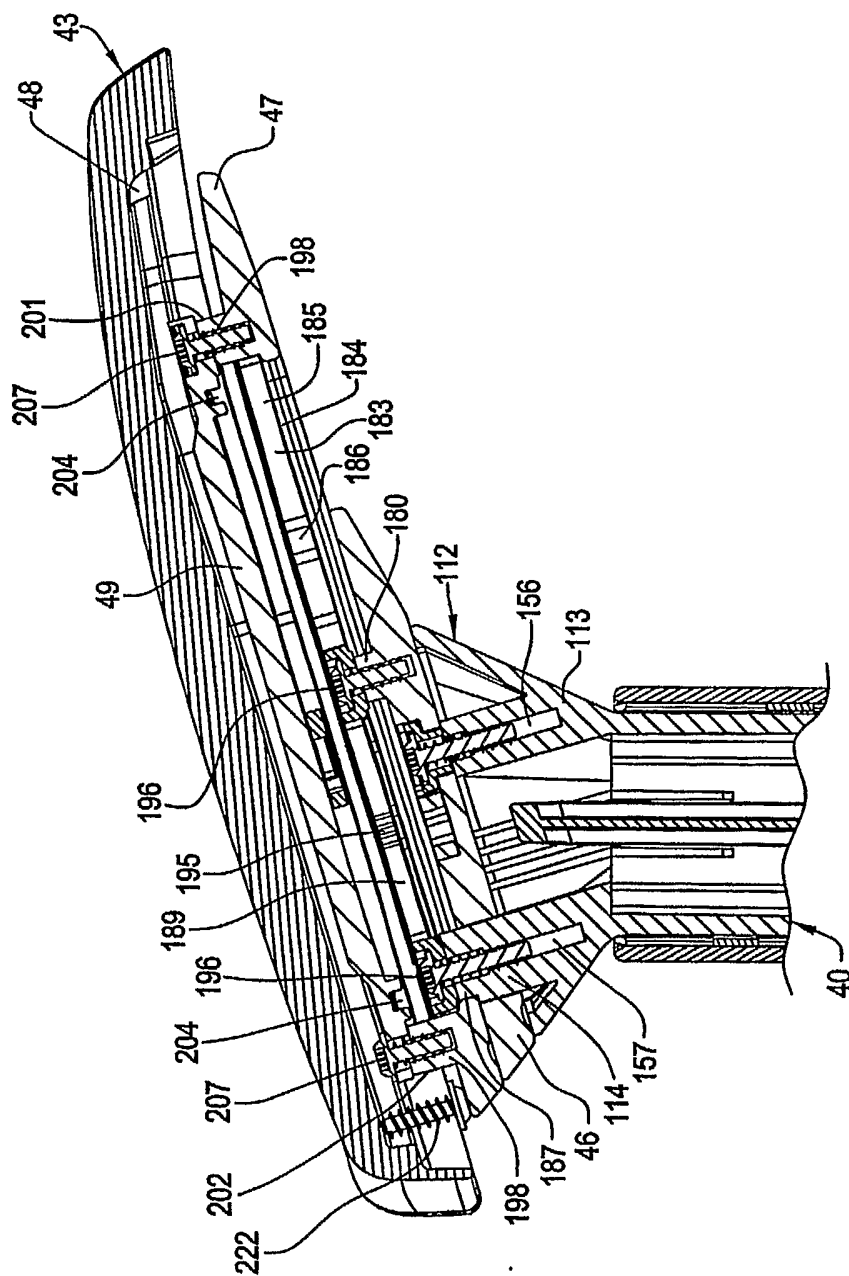

FIG.30

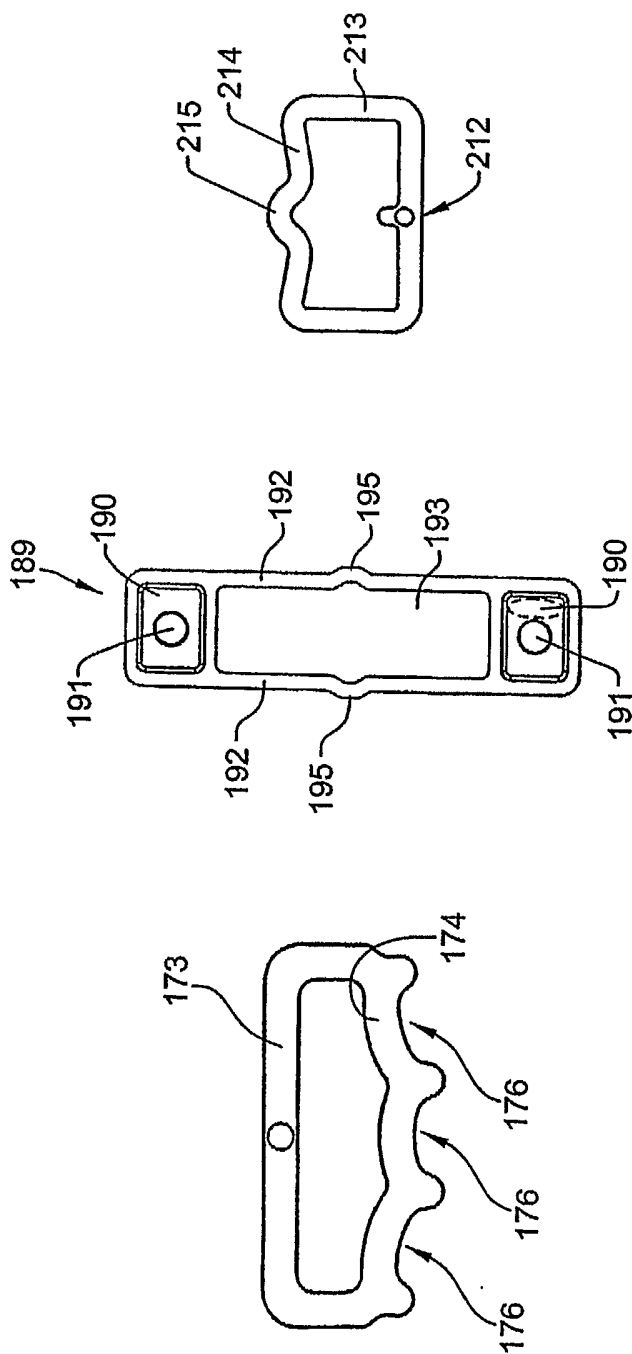

FIG. 33

FIG. 32

FIG. 31

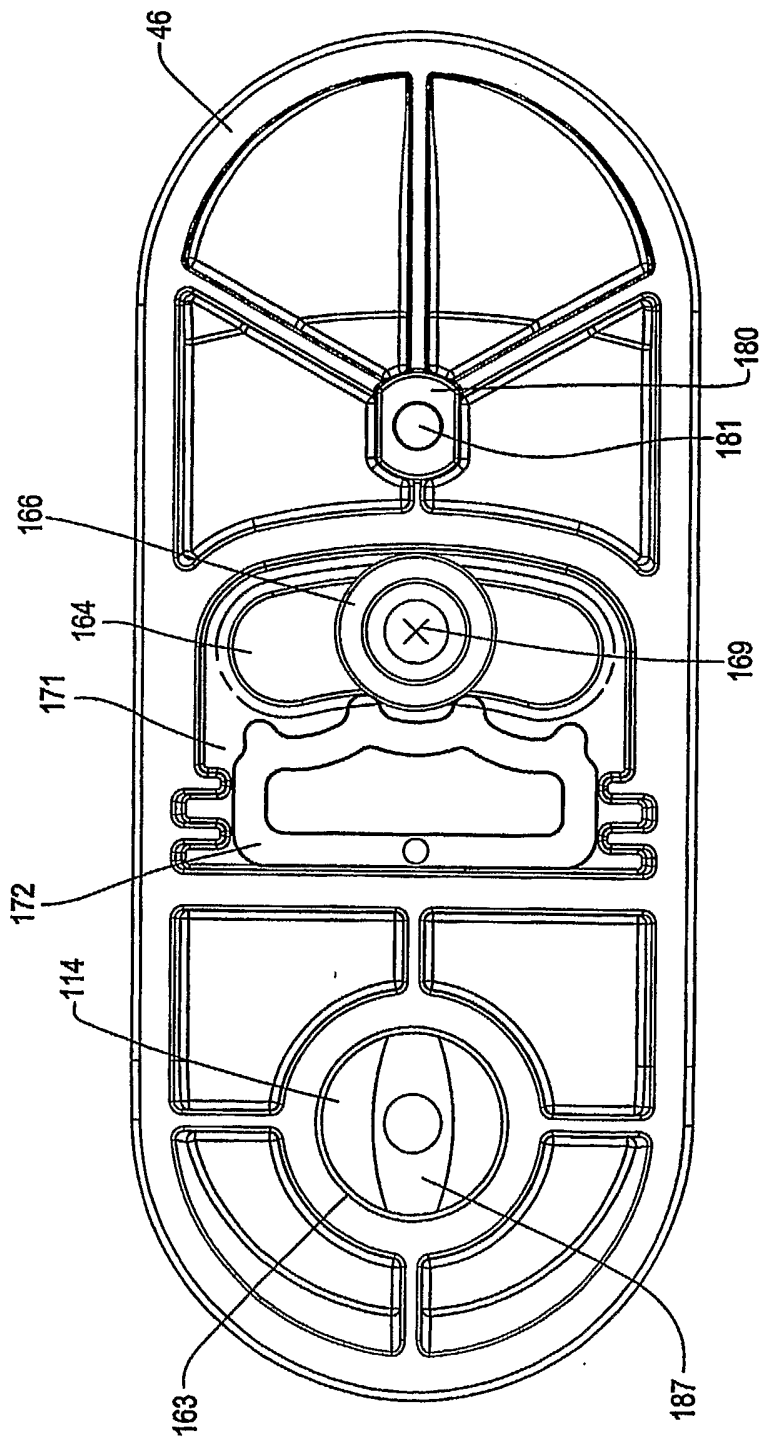

FIG. 34

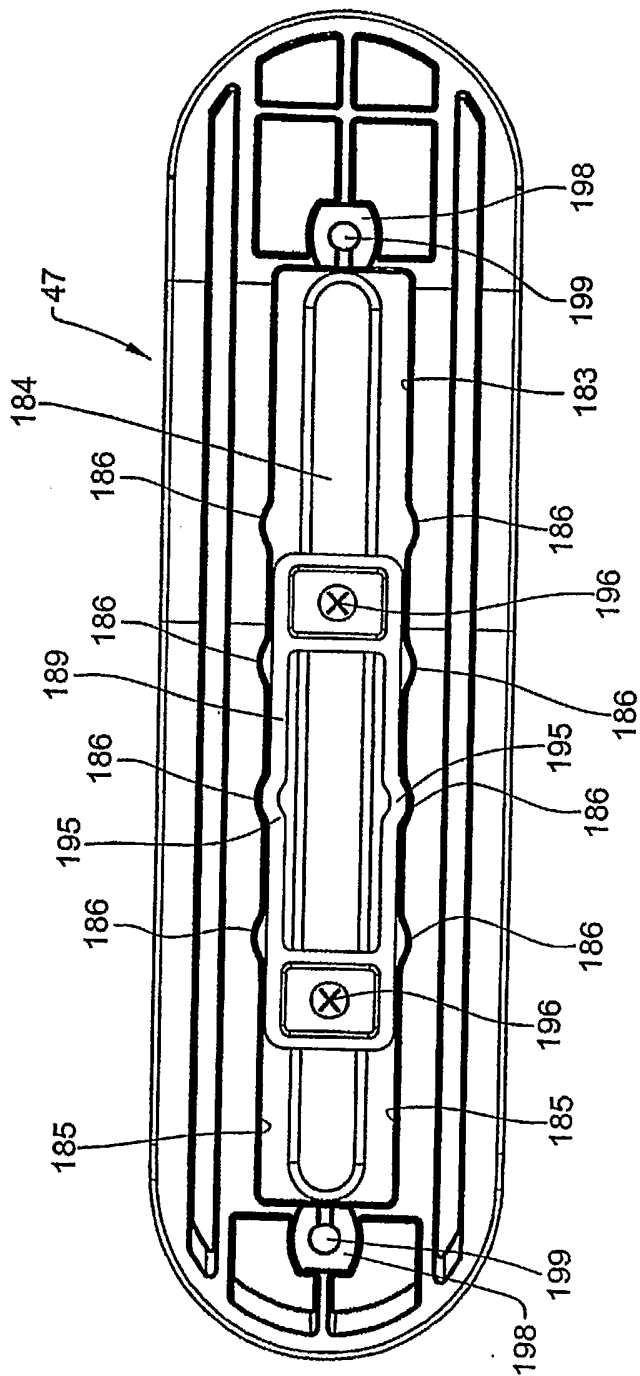

FIG. 35

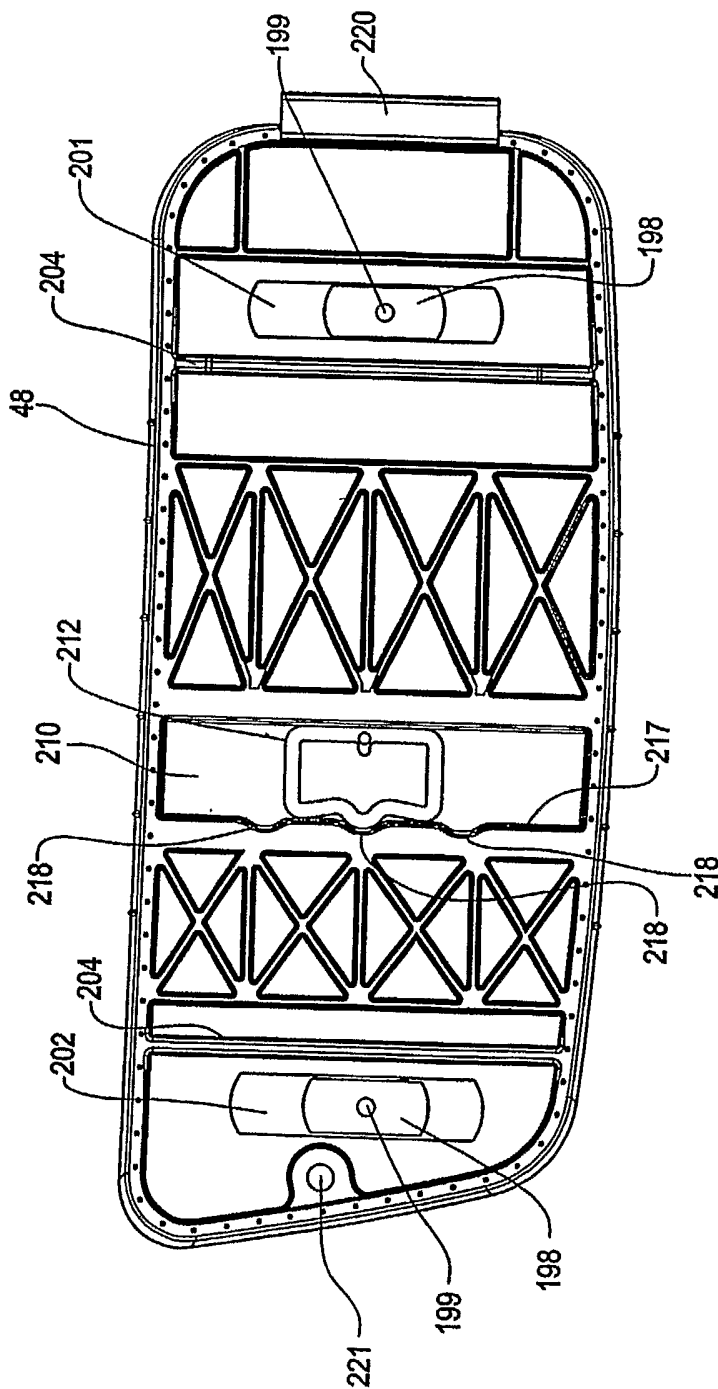

FIG. 36

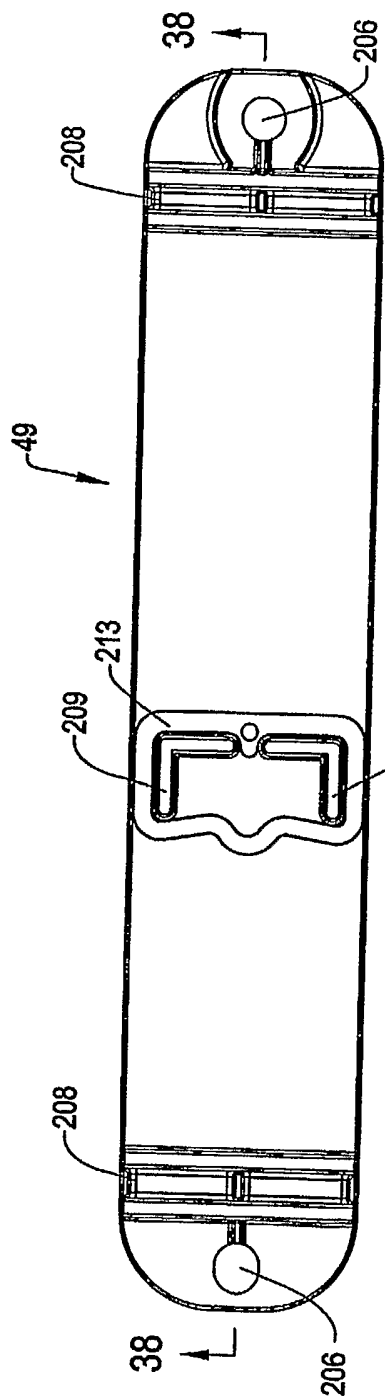

FIG. 37

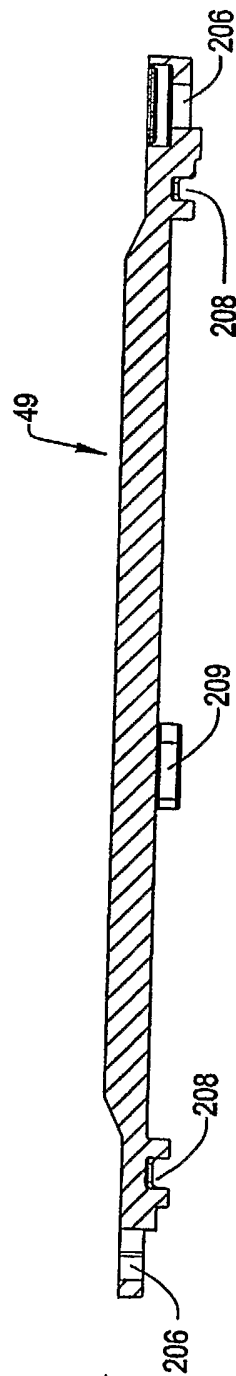

FIG. 38