

No. 678,188.

Patented July 9, 1901.

J. MACBETH.
HOISTING CRANE.

(Application filed July 21, 1900.)

(No Model.)

3 Sheets—Sheet 1.

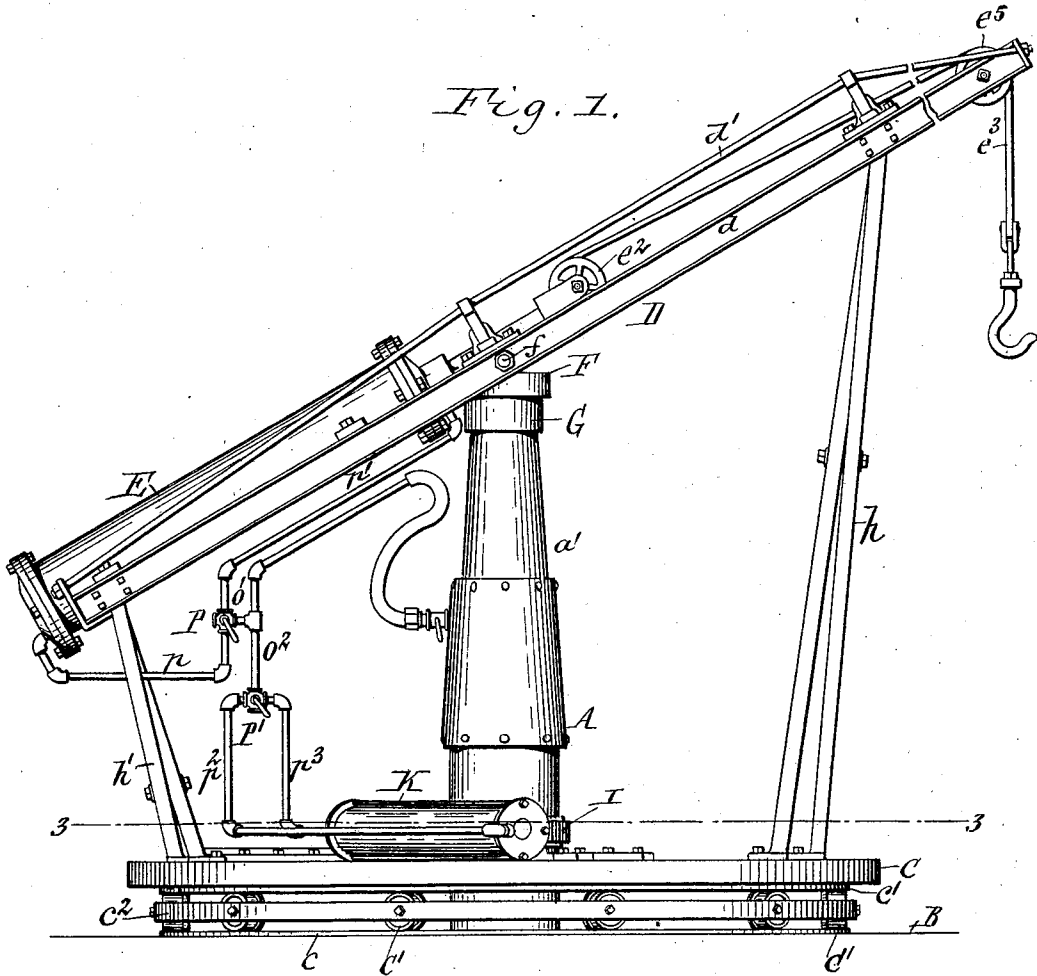

Witnesses:
E. A. Volk
F. F. Schuyler

James Macbeth Inventor
By Wilhelm Brown
Attorneys.

No. 678,188.

Patented July 9, 1901.

J. MACBETH.
HOISTING CRANE.

(Application filed July 21, 1900.)

(No Model.)

3 Sheets—Sheet 2.

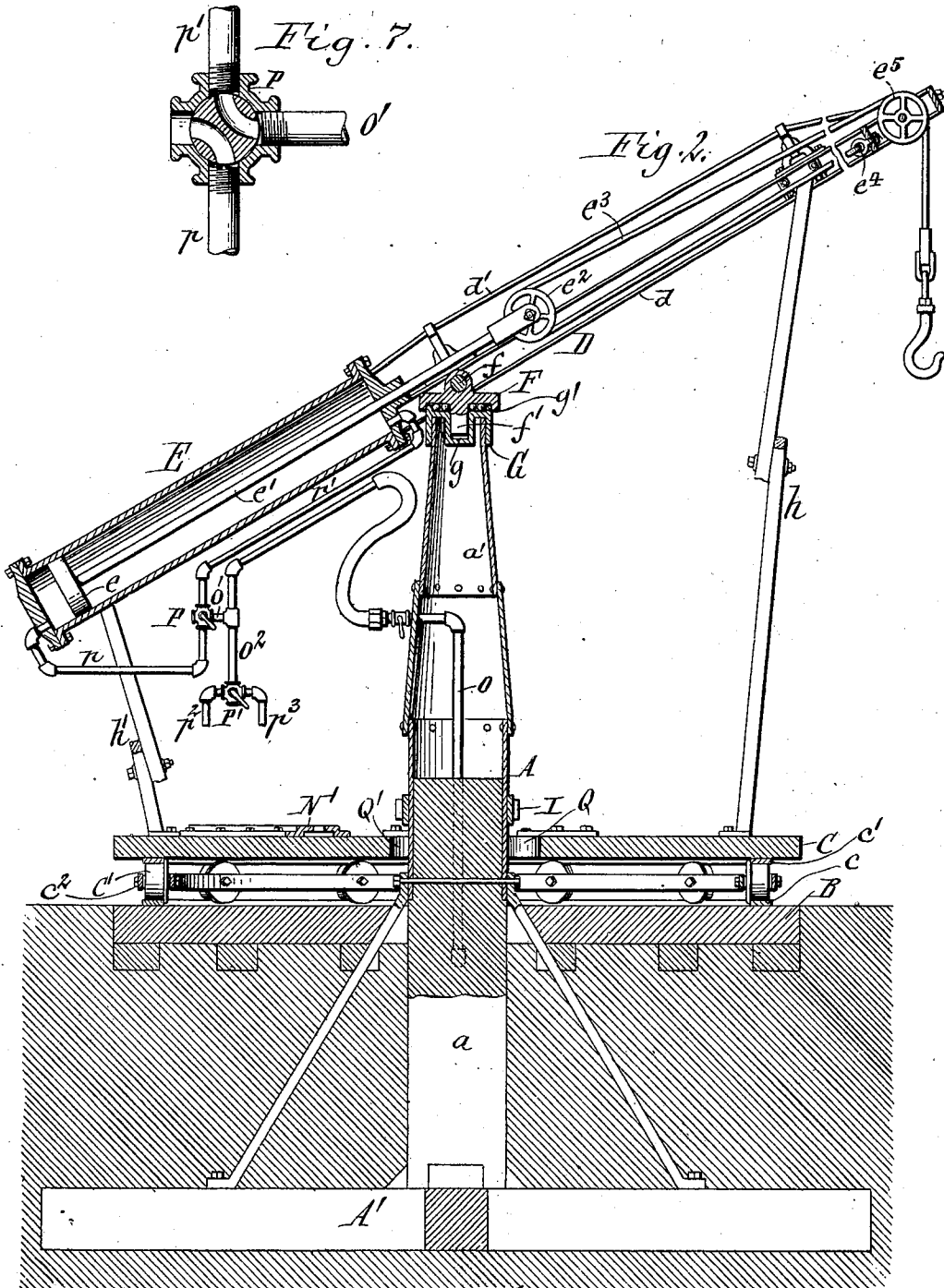

Witnesses:
S. A. Volk.
F. F. Scherzinger

James Macbeth, Inventor.
By Wilhelm Bonner
Attorneys.

No. 678,188.

Patented July 9, 1901.

J. MACBETH.
HOISTING CRANE.

(Application filed July 21, 1900.)

(No Model.)

3 Sheets—Sheet 3.

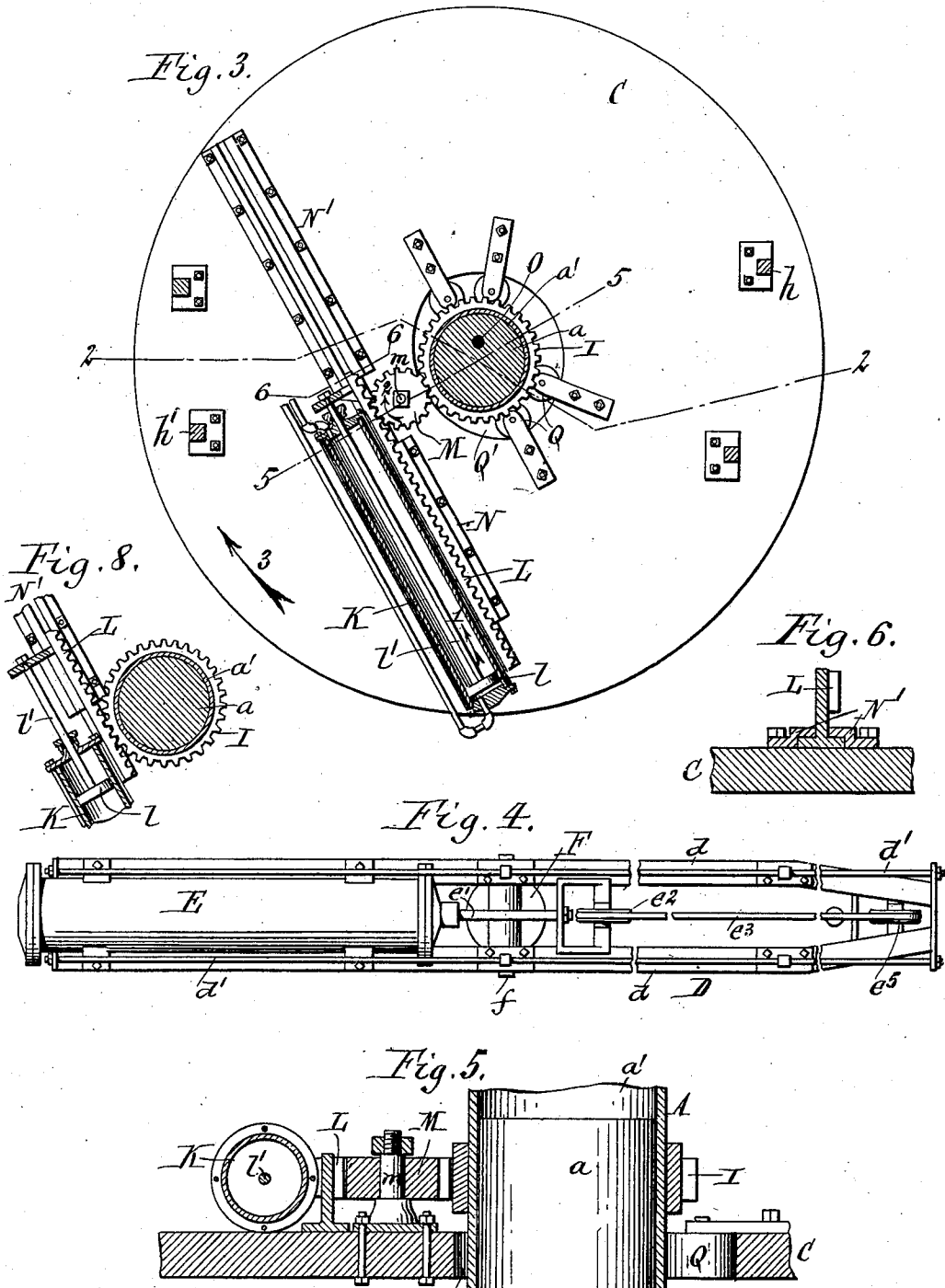

Witnesses:
 E. A. Volk.
 F. F. Schuyinger

James Macbeth, Inventor.
 By Wilhelm Spornet, Attorneys

UNITED STATES PATENT OFFICE.

JAMES MACBETH, OF BUFFALO, NEW YORK.

HOISTING-CRANE.

SPECIFICATION forming part of Letters Patent No. 678,188, dated July 9, 1901.

Application filed July 21, 1900. Serial No. 24,410. (No model.)

To all whom it may concern:

Be it known that I, JAMES MACBETH, a citizen of the United States, residing at Buffalo, in the county of Erie and State of New York, have invented new and useful Improvements in Hoisting-Cranes, of which the following is a specification.

This invention relates to that class of cranes in which the jib or boom can be swung or partly rotated about a mast or pillar and in which the movement is effected by a power mechanism.

The object of my invention is to provide a power mechanism for swinging the jib or boom which is simple, compact, and efficient and which affords a comparatively large range of rotary movement.

In the accompanying drawings, consisting of three sheets, Figure 1 is an elevation of my improved crane. Fig. 2 is a vertical section in line 2 2, Fig. 3. Fig. 3 is a horizontal section in line 3 3, Fig. 1. Fig. 4 is a top plan view of the jib or boom and the hoisting mechanism mounted thereon. Fig. 5 is a vertical section, on an enlarged scale, in line 5 5, Fig. 3. Fig. 6 is a vertical cross-section, on an enlarged scale, of the rack-bar and guide in line 6 6, Fig. 3. Fig. 7 is a detached sectional view of the four-way cock which controls the admission of the actuating fluid to the cylinder of the hoisting mechanism. Fig. 8 is a top plan view illustrating a modified construction of the boom-rotating mechanism.

Like letters of reference refer to like parts in the several figures.

A represents the mast or pillar, which in the embodiment of the invention illustrated in the drawings is a stationary structure and is firmly anchored in the ground by a suitable foundation-frame A'. This mast is preferably composed of a lower portion *a*, of wood, and a tubular upper portion *a'*, made of plate iron or steel.

B is a fixed platform which surrounds the mast about on a level with the surface of the ground and which is constructed of timbers or other suitable material.

C represents a rotary platform or turn-table which surrounds the base of the mast and which is rotatably mounted upon the stationary platform B. A convenient way of supporting the rotary platform is by flanged roll-

ers C', which run upon a circular track *c* on the stationary platform and upon which the rotary platform runs by a circular track *c'*, 55 secured to the under side of the rotary platform. The rollers C' are mounted in a circular frame *c''*.

D represents the boom or jib, which is mounted in an inclined position on the top 60 of the mast A. E represents the cylinder of the hoisting mechanism, which is mounted upon the lower portion of the boom on one side of the mast. This cylinder is provided with a piston *e* and a piston-rod *e'*, which latter is connected by a pulley *e''* with the hoisting-cable *e'''*. The latter is secured to an eye *e''''* at the upper end of the boom and runs downwardly from this eye to the pulley *e''* and thence upwardly and over a pulley *e''''* at the head of the boom. The piston is actuated by any suitable fluid under pressure, compressed air being preferred. Any other style of hoisting mechanism may, however, be mounted on the boom, if preferred. 75

The boom is preferably composed of two side bars or beams *d* of I shape, which are connected by suitable cross-pieces and stiffened by truss-rods *d'*.

F is a head which is secured to the boom, 80 at or near the middle thereof, by a transverse pin *f* or other suitable means and by which the boom turns upon the mast. This head is provided on its under side with a downwardly-projecting journal *f'*, which enters a socket 85 *g* in a cap-piece G, secured to the top of the mast. The head F and the cap-piece G are provided with overlapping marginal flanges, forming a channel which contains antifric-tion-balls *g'*, by which the head F is sup- 90 ported on the cap-piece G.

The boom is rigidly secured by any suitable means to the rotary platform C, so as to turn therewith, preferably by crossed braces *h h'*, connecting the upper and lower ends of 95 the boom, respectively, with the platform.

The mechanism by which the rotary platform and the boom carried thereby are rotated or swung about the mast or pillar is constructed as follows: I is a circular gear-rim which is 100 secured around the mast at a short distance above the rotary platform C. This gear-rim is arranged concentric with the vertical pivot line or axis about which the boom and its

rotary platform turn or swing. K is the actuating-cylinder, which is secured horizontally and tangentially to the rotary platform C and provided with a piston *l* and a piston-rod *l'*.

5 The latter projects through a stuffing-box at the inner end of the cylinder—that is to say, the end of the cylinder which is nearest the mast—and is secured to a rack-bar L, which is arranged parallel with the piston-rod between
10 the cylinder and the mast. M is a horizontal gear-wheel which is arranged near the inner end of the cylinder and which is interposed between the rack-bar L and the gear-rim I, so as to mesh with both. This gear-wheel turns
15 on a vertical arbor *m*, which projects upwardly from the movable platform C, to which it is secured, as shown in Fig. 5. N N' represent horizontal guides in which the rack-bar is guided on both sides of the gear-wheel M.
20 The piston *l* in the cylinder K is actuated by any suitable fluid under pressure, preferably compressed air.

O represents the supply-pipe for the actuating fluid, which is supported on the mast and which terminates in a branch O', leading to the cylinder E of the hoisting mechanism, and a branch O², leading to the cylinder K of the boom-turning mechanism. The branch O' is provided with a four-way cock P, which
25 controls the admission of fluid to and the exhaust from the pipes *p p'*, leading to opposite ends of the hoisting-cylinder E. The branch O² is provided with a similar four-way
30 cock P', which controls the pipes *p² p³*, leading to opposite ends of the boom-turning cylinder K.

Upon driving the piston *l* forwardly in the cylinder K, as indicated by the arrow 1 in Fig. 3, the rack-bar is moved forwardly and
40 the gear-wheel M is turned forwardly in the direction of the arrow 2 and rolls on the stationary gear-rim, thereby turning the rotary platform C in the direction of the arrow 3 and swinging the boom in that direction. As the
45 cylinder is secured to the rotary platform, it moves in the same direction. Upon reversing the movement of the piston these parts are moved in the opposite direction.

My improved boom-turning mechanism enables the rotary platform and the boom carried thereby to be swung through nearly a complete revolution. This renders this apparatus particularly desirable for use in railroad-yards, where a considerable lateral range
55 of movement of the boom is required for carrying loads over several tracks.

Q represents horizontal rollers which are mounted in the openings Q' of the platform through which the mast projects. These
60 rollers are arranged on that side of the platform over which the load is suspended and

bear against the mast, thereby centering the platform on the mast and resisting any tendency of the load to displace the platform.

In the modified construction of the boom-turning mechanism (represented in Fig. 8) the intermediate gear-wheel M is omitted and the rack-bar L meshes directly with the stationary gear-rim I. This modified construction is less desirable, for the reason that it
65 does not furnish the leverage which is furnished in the first-described construction by locating the axial line of the cylinder at a considerable distance outwardly from the gear-rim, which is rendered possible by the
70 intermediate gear-wheel M. The leverage so afforded by the first-described construction enables the boom to be swung with a smaller pressure of fluid.

Other modes of applying the principle of my invention may be employed instead of the one explained, change being made as regards the mechanism herein disclosed, provided the means covered by any one of the following
80 claims be employed.

I therefore particularly point out and distinctly claim as my invention—

1. The combination of a rotatable platform; a fluid-pressure cylinder and piston arranged with reference to said platform in a manner
90 such as to produce the rotation of the latter upon the movement of the piston in its cylinder; a stationary boom-support cooperating with said cylinder and piston to produce
95 such rotation; an inclined boom supported intermediately of its extremities upon said support and having a rotatable movement thereon; means for securing said boom in a position stationary relative to said platform,
100 whereby said platform and boom will have a corresponding movement; and means for supplying pressure to the cylinder.

2. The combination of a rotatable platform; a stationary boom-support; a fluid-pressure cylinder and piston cooperating therewith,
105 said cylinder and piston being arranged with reference to said platform in a manner such as to produce the rotation of the latter upon the movement of the piston in its cylinder; means for supplying pressure to the cylinder;
110 and an inclined boom supported intermediately of its extremities upon said support, said boom having a positive connection with the platform to cause a simultaneous rotary movement therewith, said boom being held
115 against a longitudinal movement.

Witness my hand this 18th day of July, 1900.

JAMES MACBETH.

Witnesses:

THEO. L. POPP,
CLAUDIA M. BENTLEY.