

Jan. 21, 1969

E. H. KUSTER

3,423,058

PROTECTIVE GARMENT HANGER BRACKET

Filed March 6, 1967

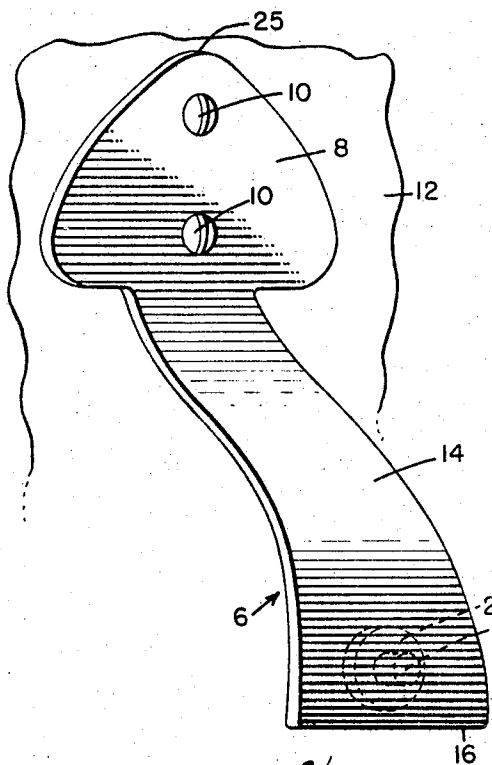

*Fig. 1*

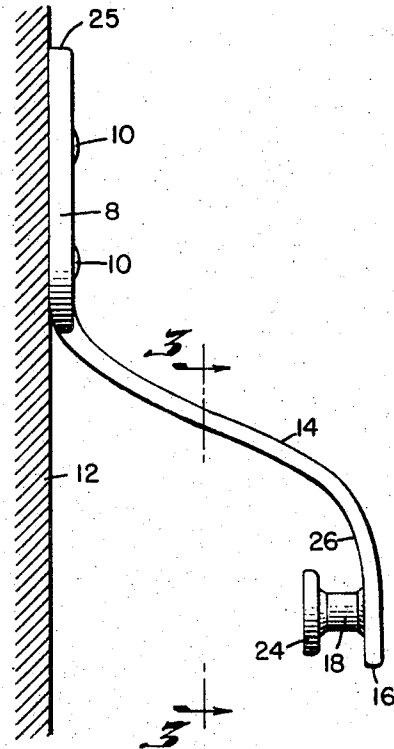

*Fig. 2*

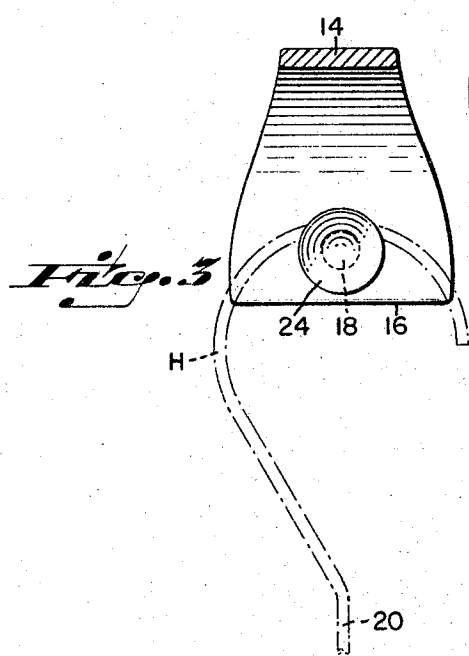

*Fig. 3*

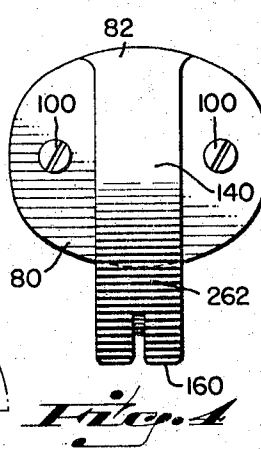

*Fig. 4*

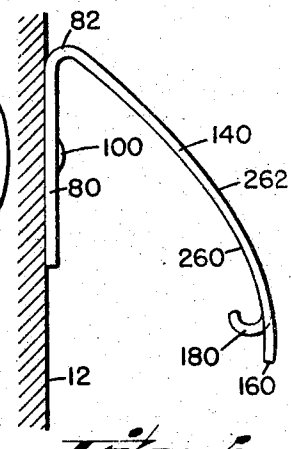

*Fig. 5*

INVENTOR.

EDWARD H. KUSTER

BY

*Kennedy and Schenk*  
ATTORNEYS

1

3,423,058

**PROTECTIVE GARMENT HANGER BRACKET**

Edward H. Kuster, Marblehead, Ohio  
(3908 Beech St., Cincinnati, Ohio 45227)

Filed Mar. 6, 1967, Ser. No. 621,012

U.S. Cl. 248-301

2 Claims

Int. Cl. A47f 7/19, 5/08

**ABSTRACT OF THE DISCLOSURE**

The garment hanger bracket is constructed to suspend but one garment of fur or other material which is vulnerable to marking or defacement by contact with adjacent articles or surfaces. As constructed, the shank of the protective hanger bracket is smooth and inclined so as to induce gravity drop of any clothing or article placed thereon in contact with the garment to be protected; and the protected garment is so suspended from a nether portion of the hanger shank, as to keep said garment free of appreciable contact with a wall or other surface supporting the bracket. The nether surface of the shank guides the hook end of a conventional clothes hanger into suspension position upon the bracket shank.

*Brief summary of the invention*

The present invention relates to a protective garment hanger bracket which is adapted particularly for hanging delicate garments of fur, velvet, or other materials subject to defacement or marking incident to careless handling or storing of such garments. The hanger bracket may comprise a mounting base for attachment to a wall or other upright supporting surface, and a rigid shank portion extended from the base, terminating in a free end which carries a suspension element or lug to suspend the wire hook portion of a common garment hanger. In use, the free end of the shank and its lug are spaced a considerable distance from the wall or supporting surface, and the device is so constructed that only one garment on a hanger can be suspended thereby.

An object of the invention is to provide a simple, inexpensive, yet effective bracket means for suspending, with the aid of a conventional garment hanger, a delicate garment of the character stated, in such manner as to prevent crushing, compacting, marking or defacing of the garment by reason of contact with other garments or adjacent objects or surfaces.

Another object of the invention is to provide a protective hanger bracket for the purposes stated, and which is so constructed as to prevent the hanging of objects or garments additional to a single delicate garment to be protectively suspended thereby.

A further object of the invention is to provide a protective hanger bracket of the character stated, which easily and simply may be mounted upon any upright surface such as a wall, a door, or a trim board for example, using ordinary fasteners such as screws, nails or the like; and to provide such a bracket which is pleasing in appearance.

Another object of the invention is to provide a hanger bracket having the hereinabove described characteristics, which includes means for spacing the hanger from which a garment is suspended from an upright surface by an amount whereby to preclude contact of the supported garment with said surface.

Still another object of the invention is to provide an improved hanger bracket with a shank portion which extends in a downwardly inclined direction from an upper end adjacent a mounting member, to a free lower end spaced below and forwardly of its said upper end, and wherein suspension means, engageable by the hook of a conventional clothes hanger, are disposed adjacent the

2

lower end of said shank and extended rearwardly toward the mounting member, said suspension means being concealed in front elevation of the hanger bracket.

The foregoing and other objects are attained by the means described herein and illustrated upon the accompanying drawing, in which:

FIG. 1 is a perspective view of the improved hanger bracket.

FIG. 2 is a side elevational view of the hanger bracket.

FIG. 3 is a cross-section taken on line 3—3 of FIG. 2.

FIG. 4 is a front elevation of a modification.

FIG. 5 is a side view of the FIG. 4 modification.

For the proper care of certain types of garments not in use, it is desirable that they be suspended on garment hangers in such manner as to protect the garments against crushing, creasing, or compacting which might mark or otherwise detract from the appearance thereof. This is particularly true of garments made from furs, such as fur coats, or jackets, stoles of fur, and garments constructed of pile fabrics of which velvet is an example. To avoid defacement or injury to such garments when stored or hung, it is desirable that they be suspended individually out of contact with other garments or adjacent objects or surfaces which might induce marking thereof.

In accordance with the present invention, a novel form of protective hanger bracket is provided, which in use suspends the garment draped upon an ordinary coat hanger, in such manner that the garment is kept clear of contact with other garments or nearby objects which might otherwise mark or depreciate the appearance of the garment suspended thereby. In general, the improved bracket adequately spaces a hanger-draped delicate garment from all nearby surfaces, and renders impossible the hanging of other garments upon the same bracket, in position to contact the delicate garment to be protected.

With reference to the accompanying drawing, the reference numeral 6 denotes the improved hanger bracket, which includes a mounting base 8 to be secured, as by means of screws 10 or other common fasteners, to any suitable upright surface or support 12. Surface 12 may be that of a wall, a door, or any other appropriate structural element capable of supporting the bracket in proper position for use. The ease with which the bracket may be secured to support 12, as by means of two simple fasteners 10, is apparent from the drawing.

From the mounting base 8 may extend an elongate substantially rigid shank 14, having a free lower end portion 16 which is spaced a substantial distance from support surface 12, and from the mean plane of base 8. The end portion 16 carries a suspension means 18 for the hook H (FIG. 3) of a conventional clothes hanger 20. It may be disposed below the upper end of shank 14, as suggested by FIG. 5.

Suspension means 18 may be a short stud or lug having preferably a head 24 or equivalent means to preclude accidental displacement of the hook H of hanger 20 therefrom. The head 24 preferably projects toward the extended plane of base 8, but is spaced from said plane a distance such that it restrains hook H against movement to a position in close proximity with support surface 12; or, otherwise stated, any garment suspended from hanger 20 will be kept from contact with surface 12, by the limiting effect of head 24. In a typical construction, head 24 may be spaced three inches, more or less, from surface 12.

The suspension means 18 may be a part securely anchored against the nether face 26 of shank 14, or it may be formed as a stud integral with the lower end portion of the shank, if desired. The suspension means 18 in its shape or formation, may be subject to considerable variation, so long as it performs to prevent the application of more than one hanger hook H thereto. If

desired, the suspension means may comprise an apertured lug on the nether face of shank 14 to accommodate the hook H of a clothes hanger.

It will be noted that shank 14 inclines downwardly and outwardly from base 8 at an angle such that no part of the shank other than stud 18, may be used as a means to support a garment or a garment hanger. The upper portion 25 of base 8 is of insufficient width to support a garment or a clothes hanger hook, and if desired, said portion 25 may be provided with a slope downwardly and outwardly to prevent its use for suspension purposes.

From the foregoing, it will be apparent that the protective hanger bracket of the invention is so constructed that a garment hung from the single suspension means 18, by means of a conventional clothes hanger or otherwise, will be protected against crushing and consequential marking or defacing because of the garment being at all times adequately spaced from wall or support 12, and further, because of the inability of shank 14 and base 8 to suspend additional garments or objects over or against a single garment hung from suspension means 18.

The capacity of suspension means 18 to accommodate clothes hangers or garments should be so limited, that only one garment or clothes hanger may be accommodated thereby.

While shank 14 is shown generally S-shaped in contour, the contour may be varied so long as the shape or the inclination thereof is effective to prevent or thoroughly discourage its use as a hook or projection for the hanging of garments. The shank accordingly might be straight rather than curved, and sufficiently inclined to cause any garment or article placed thereon, to slide from it by force of gravity. By preference, the shank is made smooth as well as inclined, and is free of projections to assure its use as a suspension device for only a single or individual garment or the like to be hung or stored.

In the modification, FIGS. 4 and 5, the mounting base 80 is shown depending from the upper end 82 of shank 140; however it should be understood that base 80 might just as well project upwardly from end 82. The suspension means 180 is the equivalent of suspension means 18 of FIG. 2, and is adapted to suspend but one conventional clothes hanger. As shown, suspension means 180 may be formed integrally with the lower end portion of the shank, by punching a tongue from the end portion and turning it upwardly as in FIG. 5, along the nether face 260 of the shank. In this construction, as in FIGS. 1, 2 and 3, the outer surface 262 of the shank is made smooth and inclined, without projections, to prevent the hanging of garments or clothes hangers thereon in addition to the one suspended from member 180. At 82, where the shank meets base 80, the structure is to be incapable of supporting the hook H of a coat hanger.

In both forms of the hanger bracket illustrated, the

nether or inside surface 26 of FIG. 2, and 260 of FIG. 5, is made smooth and continuous from the base of the bracket to the suspension means 18 or 180. Said surfaces 26 and 260 thereby serve as guides or tracks along which the hook H of a conventional coat hanger may be slid, to ensure effortless engagement thereof with the suspension means in hanging a garment thereon.

The protective hanger bracket of the invention may be very simply and inexpensively produced as a stamping, molding, casting or the like, using any appropriate material satisfying the requirements of a hanger for clothing. Thus, the material employed may be metal, plastic, hard rubber, or any one of many composition materials that may be formed or shaped as required.

It is to be understood that various modifications and changes may be made in the structural details of the device, within the scope of the appended claims, without departing from the spirit of the invention.

What I claim is:

1. A protective hanger bracket for a garment to be protected against defacement by contact with other objects, said hanger bracket comprising a base having a flat vertical face for mounting thereof upon an upright supporting surface; an elongate shank including an outer face and a nether face all portions of both said faces being inclined outwardly and downwardly from the base, said nether face being spaced from the mean plane of the base; and a suspension stud fixed upon the nether face of the shank for suspension of only a single garment therefrom, said suspension stud including a head of lesser width than the width of the shank nether face, said head being spaced at a distance from the plane of the base sufficient to preclude substantial interception of a hanger-suspended garment thereon with the plane of said base; and said entire outer face of the shank being at a steep inclination to induce gravitation from the shank of an article placed at any location upon said outer face.

2. The hanger bracket as specified by claim 1, wherein said nether face of the shank provides a continuous track for guiding onto the suspension means the hook of a conventional clothes hanger slidingly advanced along said nether face in a downward direction.

#### References Cited

##### UNITED STATES PATENTS

285,094	9/1883	Wode et al.	
1,103,579	7/1914	Hall	248—304 XR
1,567,037	12/1925	Cavanna	211—35
2,564,891	8/1951	Ganter	248—262

JOHN PETO, *Primary Examiner.*

U.S. Cl. X.R.

211—87, 248—262