

616758

COMMONWEALTH OF AUSTRALIA

Form 1

Regulation 9

Patents Act 1952

APPLICATION FOR A STANDARD PATENT

I, MICHAEL BRIAN RENTON of 31 - 4th Avenue, Parktown North, Johannesburg 2193 South Africa, hereby apply for the grant of a standard patent for an invention entitled WATER TREATMENT DEVICES which is described in the accompanying complete specification.

The actual inventor of the said invention is: MICHAEL BRIAN RENTON

MY address for service is SMITH SHELSTON BEADLE, 207 Riversdale Road (P.O. Box 410), Hawthorn, Victoria, 3122 (Attorney Code SA)

Details of basic application:-

Number of Basic Application: 88/3752
Convention Country in which
Basic Application was filed: South Africa
Date of Basic Application: 25th May, 1988
ISO Code: SA

DATED THIS 25th DAY OF May 1989

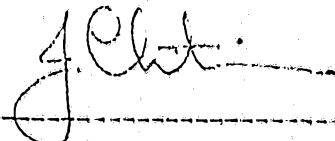

SMITH SHELSTON BEADLE
Patent Attorneys for the Applicant

TO: The Commissioner of Patents

Our Ref: #3528 JC:GD 35ren

M 0 0 5 - 3 5 2 8

PATENT DECLARATION FORM
(CONVENTION OR NON-CONVENTION)

DECLARATION IN SUPPORT OF APPLICATION FOR A PATENT

Insert name of applicant.

In support of the application made by Michael Brian Renton

Insert title of invention.

for a patent for an invention entitled: Water Treatment Devices

Insert full name(s) and address(es) of person(s) making declaration. If applicant, a company person must be authorised to make declaration.

I/We Michael Brian Renton of 31 Fourth Avenue, Parktown North, Johannesburg, South Africa

do solemnly and sincerely declare as follows:

- * 1. (a) I am/~~we~~ ~~are~~ the applicant(s) for the patent.
- * OR (b) ~~I am authorised by the above inventor(s) to apply for the patent on his behalf.~~
- * 2. (a) I am/We are the actual inventor(s) of the invention.
- * OR (b) _____

Delete alternatives which do not apply

Insert name(s) and address(es) of actual inventor(s).

is/are the actual inventor(s) of the invention and the facts upon which the applicant(s) is/are entitled to make the application are as follows:--

Insert details of entitlement to apply, e.g. Applicant is assignee of inventor(s)

- 3. The basic application(s) as defined by Section 141 of the Act was/were made in the following country or countries on the following date(s) by the following applicant(s) *M. B. Renton*
 in South Africa on 25th May 1988
 by Michael Brian Renton
 in _____ on _____ 19____
 by _____
 in _____ on _____ 19____
 by _____
 in _____ on _____ 19____
 by _____

Delete 3 and 4 if application non-convention. Otherwise insert details of basic application(s).

- 4. The basic application(s) referred to in paragraph 3 of this Declaration was/were the first application(s) made in a Convention country in respect of the invention the subject of the application.

Place and date of Signature.

Declared at Johannesburg this 22nd day of May 1989

NO ATTESTATION
OR SEAL

M. B. Renton

Signature(s) of declarant(s).

To: The Commissioner of Patents,
Australia

SANDERCOCK, SMITH & BEADLE,

P.O. Box 410, Hawthorn, 3122, Australia
cables: Sandpat Melbourne
telex: 34491, Sandpat

(12) PATENT ABRIDGMENT (11) Document No. AU-B-35215/89
(19) AUSTRALIAN PATENT OFFICE (10) Acceptance No. 616758

(54) Title
WATER TREATMENT DEVICES

(51)⁴ International Patent Classification(s)
C02F 001/76

(21) Application No. : 35215/89

(22) Application Date : 25.05.89

(30) Priority Data

(31) Number (32) Date (33) Country
88/3752 25.05.88 ZA SOUTH AFRICA

(43) Publication Date : 30.11.89

(44) Publication Date of Accepted Application : 07.11.91

(71) Applicant(s)
MICHAEL BRIAN RENTON

(72) Inventor(s)
MICHAEL BRIAN RENTON

(74) Attorney or Agent
CARTER SMITH & BEADLE, Qantas House, 2 Railway Parade, CAMBERWELL, VIC 3124

(57) The invention is concerned with a water treatment device of the kind used in treating water in for example a swimming pool or other body, the device being adapted to contain water treatment material (i.e. material that slowly release gasses such as chlorine into the water and that has a specific gravity greater than that of water) (which water treatment material is hereinafter referred to as "WTM"), the device comprising (a) a container arranged to retain the WTM therein but to permit water access thereto and (b) buoyancy means. Such a water treatment device is hereinafter called a "WT device".

CLAIM

1. A WT device comprising:

- a. buoyancy means giving a buoyancy to the WT device such that when the container contains a predetermined amount of WTM, the container will sink to the bottom of the water containment while the container will float on the surface of the water when it does not contain any WTM or a small amount of such WTM, and
- b. support means located at the periphery of the container to support the container off the bottom of the water containment.

This invention relates to water treatment devices.

5 The invention is concerned with a water treatment device of the kind used in treating water in for example a swimming pool or other body, the device being adapted to contain water treatment material (i.e. material that slowly release gasses such as chlorine into the water and that has a specific gravity greater than that of water) (which water treatment material is hereinafter referred to as "WTM"), the device comprising (a) a container arranged to retain the WTM therein but to permit water access thereto and (b) buoyancy means. 10 Such a water treatment device is hereinafter called a "WT device".

15 According to one aspect of the invention there is provided a WT device comprising buoyancy means giving a buoyancy to the WT device such that when the container contains a predetermined amount of WTM, the container will sink to the bottom of the water containment while the container will float on the surface of the water when it does not contain any WTM or a small amount of such WTM and support means located at the periphery of the container to support 20... the container off the floor of the water containment.



(which may be a swimming pool or resevoir). At the centre portion of the container base there may be a projection, which is preferably part spherical in shape so that the WT device may rock slightly on movement of water therearound, the support means limiting the amount of such rocking movement.

The WT device may in a preferred embodiment comprise a blow moulded body having a lower portion to receive WTM, ^{and} an upper portion having an outlet opening through which gasses or treated water can escape.

The buoyancy means may conveniently comprise a chamber into which gasses may be received. The bouyancy means may further or a.lternatively comprise a buoyancy member.

The support means may comprise a plurality of narrow feet or it may comprise a skirt having aper- tures therein through which water may pass.

Embodiments of the invention will now be descri- bed by way of example with reference to the accom- panying drawings in which the sizes of various parts are exaggerated for the purposes of clarity.



SHORT DESCRIPTION OF DRAWINGS

Figure 1 is a side view partially broken away of a WT device of the invention.

Figure 2 is an underplan of the WT device.

5 Figure 3 is a detail side view partially broken away of a modified WT device of the invention.

Figure 4 is a view similar to Figure 1 of another WT device of the invention.

Figure 5 is a plan of the WT device of Figure 4, and

10 Figure 6 is a view similar to Figure 1 of a modified device of the invention.

DESCRIPTION OF A FIRST EMBODIMENT

Referring now to Figures 1 to 2, there is shown a diagrammatically a WT device 10 of the invention for use in the treatment of water in a swimming pool. The device comprises a blow moulded plastics container of circular cross-section and relatively stubby shape and having a lower chamber 12 and an upper chamber 14.

15 The lower chamber 12 is of enlarged diameter and has an imperforate base part 16 at the periphery of which is formed with a dependant skirt 18 in which enlarged openings 20 are formed. The centre of the base part 16 has a depending pivot member 19 having a part spherical end which extends further down than the skirt 18. Thus when the device 10 is in the pool, it

20

25



can rock slightly on the dome 19 due to the movement of water therearound to agitate the contents of the chamber 12. The skirt 18 will however limit such rocking movement to prevent the device 10 from falling on its side.

5 The upper chamber 14 is of smaller diameter than the chamber 12 and is joined thereto by a flange member 22. The upper end of the chamber 14 has an inwardly directed flange 24 with rounded corners 26 and a central opening 28 which is closed and sealed off by a hollow plug 30. The plug 30 has a skirt 32
10 extending below the flange 24. The plug 30 contains a buoyancy member 34 constituted by a closed cell foamed plastic material such as polyvinylchloride or polyurethane material.

 Formed on the outer corner 26 of the flange 24 is a pair of nodules 36 that can be cut off to form openings 38 of small
15 cross-section (say about two millemetres in diameter).

 In use, the lower chamber 12 contains WTM in the form of whole (or broken parts of) conventional stabilised chlorine pills which have a density greater than that of water. The amount of chlorine pills contained has a mass equivalent to,
20 say, four such pills. A user will now cut off both of the nodules 36. The device 10 is now thrown into a swimming pool. Because of the mass of the contents of the lower chamber 12, this will soon be lowermost and the pivot member 19 and the skirt 18 will come to rest upon the floor (shown
25 diagrammatically at 39) of the swimming pool. The water in the pool will now pass through the openings 38 left by removing the nodules 36 to come into engagement with the pill material. The



water will react with the WTM which will give off amounts of chlorine treated water and gasses. The gasses will move to the upper portion of the chamber, where they form a bubble which provides buoyancy for the device 10. The treated water escapes
5 through openings 38 to chlorinate the pool water.

After the container has been in the pool a certain amount of time, most of the pill material will have been dissolved or converted into gas. The buoyancy of the gas in the plug 30 and the effect of the buoyancy device will be such that it overcomes
10 the mass of the remaining pill material. The device 10 will now float to the surface of the swimming pool and the user can see that the device has served its use and can now be discarded and replaced.

If the pool is used by swimmers so that additional
15 chlorination is required, the rocking of the device on the pool floor will agitate the pill material and water in the container increasing the amount of gasses given off and



abrading away pill residue. This residue will fall to the bottom of the container and bring fresh surfaces of the pill material into contact with the water in the container.

5
10
It will be seen that due to the shape of the container and in particular the support means constituted by the skirt 18, the mass of the WT material in the lower chamber and the buoyancy means 30, the container will always be in an upright position. Thus the openings 38 will always be away from the pool floor. Furthermore as the skirt 18 permits water flow below the base plate, staining of the pool floor will be obviated or at the very least substantially minimised.

DESCRIPTION OF A MODIFICATION

15
Referring now to Figure 3, there is shown the lower end of a modified chamber 40 of the invention.



This is identical to the ^{device}chamber 10 save that instead of having a dependant skirt, the chamber is formed with support means constituted by three legs 42 on its underside at the periphery of the base part 44.

5 DESCRIPTION OF ANOTHER EMBODIMENT

The device 10 can be modified for use with un-
stabilised pill material. A grid is formed slightly
above the base of the lower chamber into which sludge
formed on the surface of the pill material may fall
10 when the chamber rocks as aforesaid so that fresh
pill material will be presented to the water to react
therewith. Such a grid is shown in and described
with reference to the embodiment of figure 6.

15 DESCRIPTION OF A FURTHER EMBODIMENT

Referring now to Figures 4 and 5 there is shown
a WT device 50 of the invention comprising a lower
cylindrical basket 52 and a closure device 54 at its
upper end. Both these parts are plastics mouldings.

20 The basket 52 has an outward flange 56 at its
upper end above which is an inwardly directed parallel
cover flange 58 at its upper end. There are a set
of radial nibs 60 formed on the upper flanges 58.
The closure device 54 has a set of openings 62 which
can receive the nibs 60 so that on insertion of the



nibs 60 into the openings 62 and on rotation of the device 54, the closure device 54 is releasably secured to the basket 52.

5 A sealed hollow handle 64 is secured to the device 54 to act both as a twist-off handle and as a bouyancy means.

10 The basket 52 has a transverse floor 66 spaced from its lower end which divides the sides of the basket 52 into a body 68 above the floor 66 and a skirt 70 below. The skirt 70 is outwardly belled so that its lower edge is larger than the floor 66. A lead weight 72 is placed ^{below} ~~below~~ the floor 66 to ensure that the basket 50 remains upright. There are a number of openings 74 through the body 68 and the skirt 70 to permit relatively free flow of water therethrough. The floor 66 is unperforated so that water cannot pass through it.

15
20 The basket 52 is of such size that it can receive therein five chlorine pills (not shown) stacked one above the other. These can be inserted into the basket by removing the closure device 54 and thereafter replacing it.



DESCRIPTION OF ANOTHER EMBODIMENT

5 In Figure 6, there is shown a further WT device 80 of the invention. The WT device comprises a main substantially cylindrical container 82. The container 82 is formed with the base plate 84 having a central projection 86 the lower end of which is part spherical and which is surrounded by a skirt 88 (similar to the skirt 18 of the first described embodiment) which at the periphery of the base plate 84 projects downwardly slightly less than projection 86. A slightly conical residue screen 90 rests on the base plate 84. At its upper end the container 82 has a peripheral recess 92. The container 82 is closed by a plug 94 having a slightly domed upper surface with a small peripheral flange 96 that fits into the recess 92. The plug 94 has an inward surface 96 leading to a deep neck 98 of about one half of the diameter of the flange 96. This neck 98 terminates in a radial flange 100 which extends to very close to the side wall of the chamber 82. The space in between the ends of the flange 100 and the side wall 82 is such as to form a choke on air and water flow from below the flange to above.

15 Formed on the walls of the container 82 at about the upper level of the neck 98 are a pair of diametrically oppositely located nodules 102. These nodules can be cut to leave openings 104 of approximately two millimetres in diameter.

20

25



A wad 106 of closed cell plastics bouyancy material of the kind which forms the member 36 described above is provided in the upper portion of the plug 94 above the surface 96.

5 The container body 82 and the plug 94 can be blow moulded from a single unit and parted along the line at the join of the flange and the upper end of the container to provide the portions as shown. Within the container is located a number of unstabilised chlorine pills 108 which rest on the residue screen 90.

10 In use, the nodules 102 are cut off and the container is held in the water, conveniently in the wier so that water can enter into the container. The water will fill the container up to a waterline 110 at the level of the flanges 100. The container 82 will now be thrown into the water where it will rest on the floor of the swimming pool with the projection and skirt ^{resting} thereon as described above. It will be seen that most of the pills 108 will be engaged with the water and these will react therewith to give off gases which will pass up between the end of the flange and the side of the container. The gases will escape through the openings 104 to chlorinate the pool water.

15

20

25



After a pill 108 has degraded sufficiently so that material falls off it through the screen 90 the remaining pills will drop down so that they will thereafter come into contact with the water and react therewith to give off gasses.

When all the pills 108 have been degraded, the buoyancy caused by the bubble of air formed within the plug 94 will lift the container to the surface of the pool. The user of the pool will then realise that the pills have been used up and the device must be replaced.

GENERAL

It will be noted that with all the devices described above, excepting for the device of Figures 4 and 5, it is necessary before discarding the device, to drain the water from the device conveniently into the weir and before throwing it away. This can most conveniently be accomplished by cutting off the central depending projection on the container.

ADVANTAGES OF THE ABOVE DESCRIBED EMBODIMENTS

Because the chlorine laden water that flows out of the basket is not exposed to bright sunlight (as would be the case if the WT device was floating close to the surface of the pool) the effectiveness of the



chlorine pill/s is enhanced. As a result of the fact
that the containers are on the pool floor and not
floating on the surface , which would have the effect
of drawing the chlorinated surface water into the
5 pool weir, there is a better distribution of treated
water through the pool water. Because the waterflow
is less at the bottom of the pool ^{and treated water} and because the gas
released from the device has greater opportunity to
treat the pool water from the bottom of the pool,
10 the effective life of the WTM is prolonged without
reducing the degree of water treatment. Furthermore,
because the container rises to the surface of the
swimming pool when the pills have become exhausted,
there is a simple but effective warning to the pool
15 owner that he must replace the water treatment device
or the WTM in the device.

As the container 10 is formed as a sealed blow
moulding, this provides the user with a supply of
chlorine which requires no direct contact in handling
20 and when the chlorine is used up, the container with
its contents becomes a throw-away item.

As the walls of the container are cylindrical
without any protrusions thereon, it is possible to
print direct on to these walls by the silk screen
25 process.



MODIFICATIONS TO THE EMBODIMENTS

The invention is not limited to the precise constructional details hereinbefore described and illustrated in the drawings. For example the parts may be of different sizes. The manner in which the closure is secured to the basket may be changed. The number of nodules may be more than two. Other bouyancy means may be provided. The bouyancy may be changed to provide earlier warning of pill depletion. Instead of chlorine pill material, the WTM may comprise any other suitable solid water treatment material. Among other such material may be chlorine granules, dry acid granules and the like.

The foamed plastic bouyancy member may be omitted and reliance placed soley on the gas bubble for the requisite bouyancy.

The claims form part of the disclosure of this specification.

THE CLAIMS DEFINING THE INVENTION ARE AS FOLLOWS:

1. A WT device comprising:

a. buoyancy means giving a buoyancy to the WT device such that when the container contains a predetermined amount of WTM, the container will sink to the bottom of the water containment while the container will float on the surface of the water when it does not contain any WTM or a small amount of such WTM, and

b. support means located at the periphery of the container to support the container off the bottom of the water containment.

10 2. A device as claimed in claim 1 wherein the container comprises a lower chamber for containing the WTM and having a base part on which the said WTM rests.

15 3. A device as claimed in claim 2 wherein the centre portion of the container base has a projection so that the WT device may rock slightly on movement of water therearound, the support means limiting the amount of such rocking movement.

4. A device as claimed in claim 3 wherein the said centre portion is part spherical in shape.

20 5. A device as claimed in claim 1 wherein the said support means is of sufficient height and shape to permit water flow between the base part and the pool floor.

6. A device as claimed in claim 1 wherein the buoyancy means comprises a buoyancy plug.

25 7. A device as claimed in claim 1 wherein the buoyancy means comprises a sealed portion of the device in which a bubble of gasses formed within the container can be received.



8. A device as claimed in claim 7 wherein the said sealed portion comprises a plug which closes an opening in the device.

5 9. A device as claimed in claim 2 further comprising an upper chamber, there being a number of small openings in the wall of the upper chamber below its upper end, through at least one of which opening gasses and treated water may escape from the container.

10 10. A device as claimed in claim 1 further comprising a residue screen on the base of the device through which degraded WTM may pass.

11. A WT device substantially as herein described with reference to the accompanying drawings.

February 20, 1991

SMITH SHELSTON BEADLE

Fellows Institute of Patent Attorneys of Australia

Patent Attorneys for the Applicant:

MICHAEL BRIAN RENTON



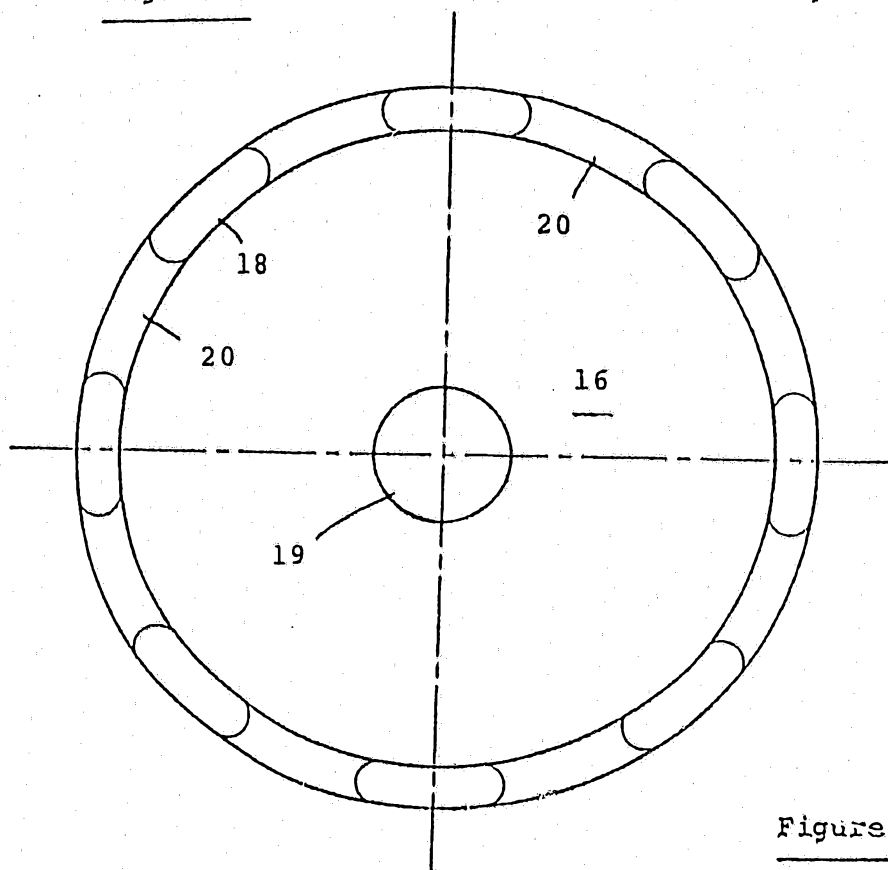
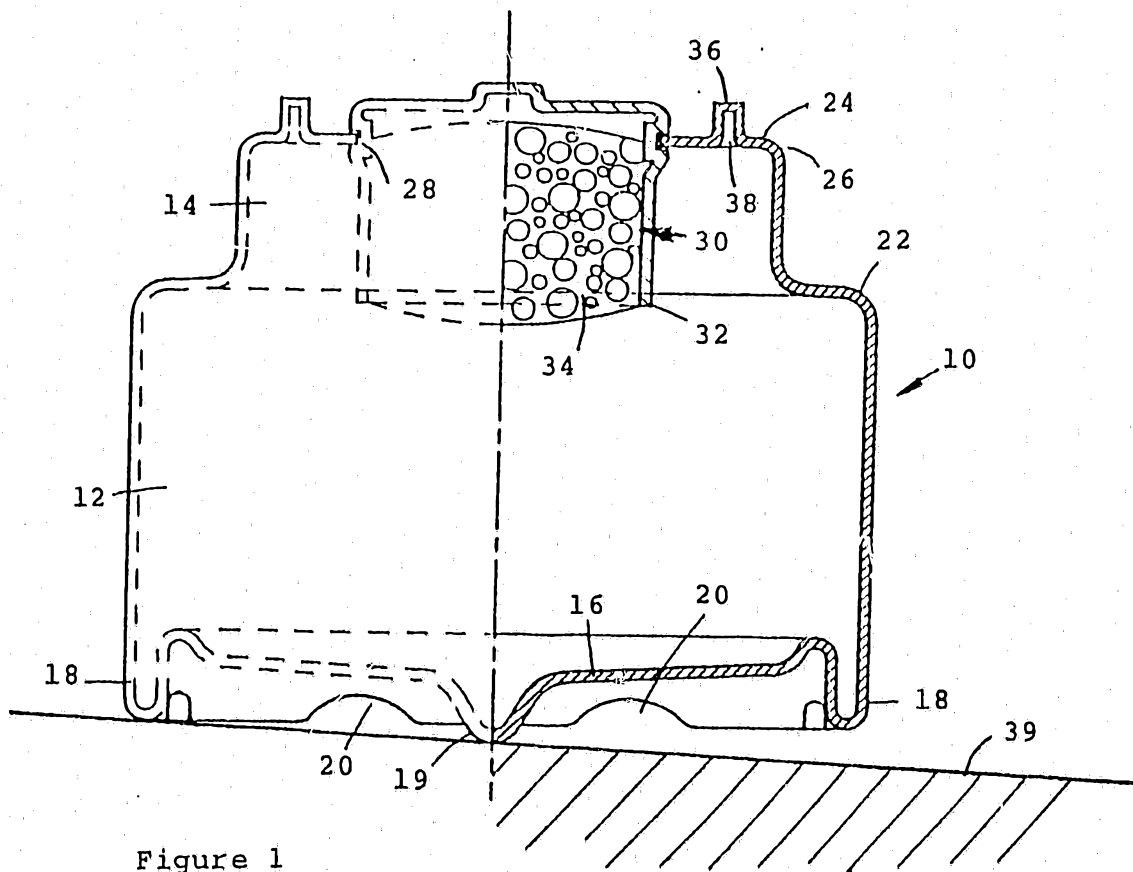

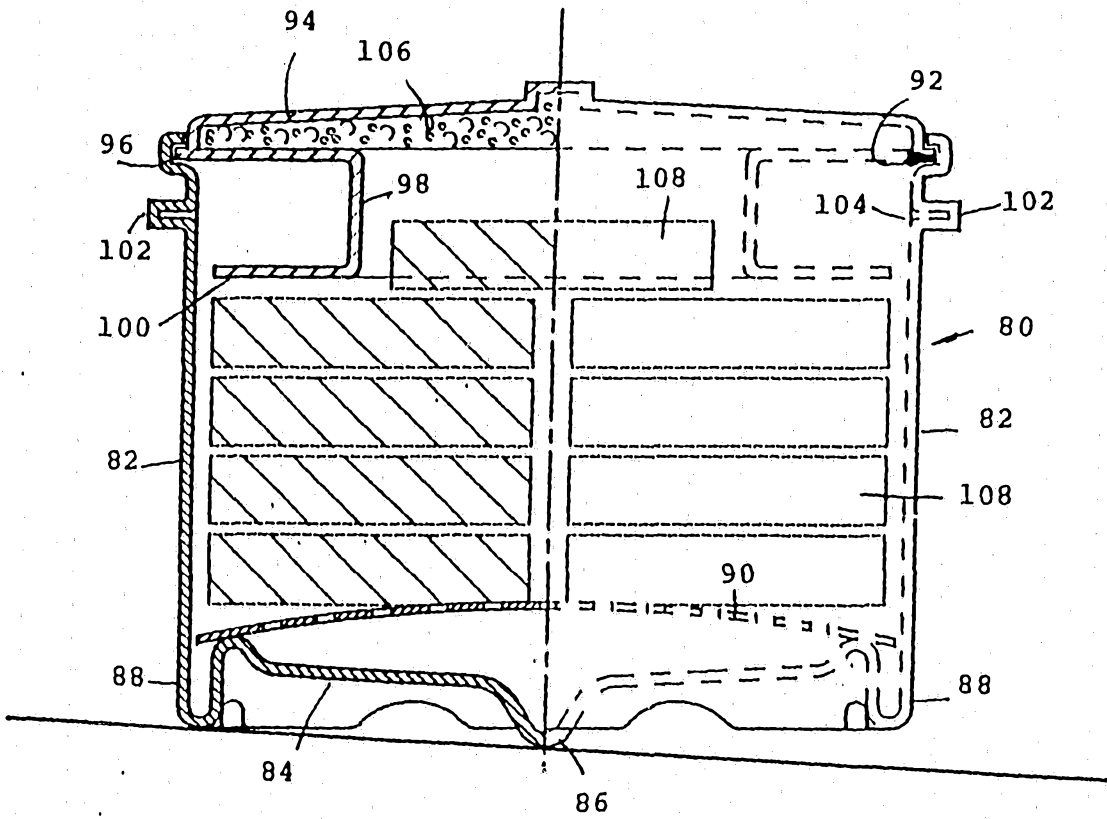

Figure 6

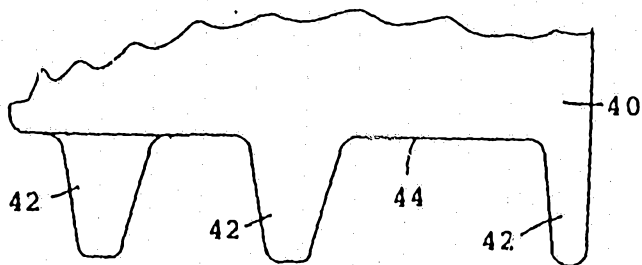

Figure 3

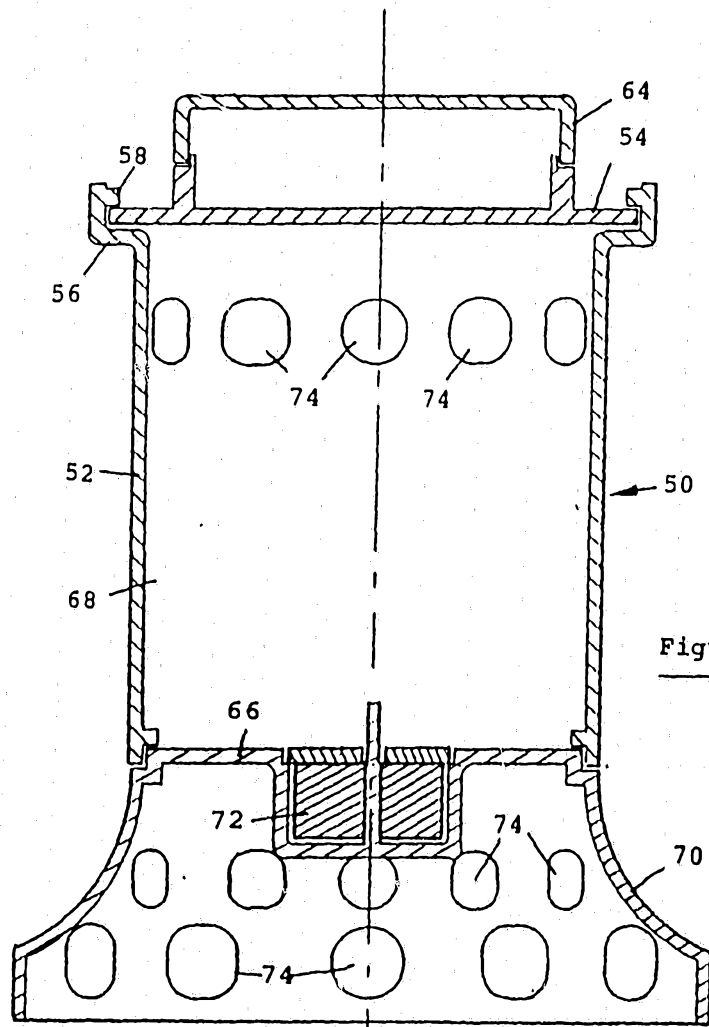

Figure 4

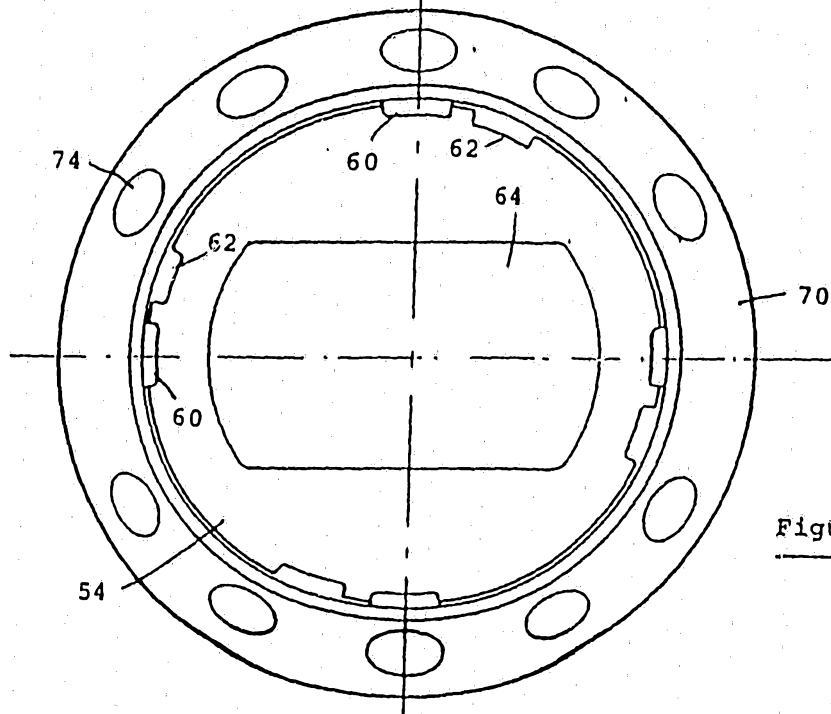

Figure 5