



US00D991066S

(12) **United States Design Patent**
Imai et al.

(10) **Patent No.:** **US D991,066 S**
(45) **Date of Patent:** **** Jul. 4, 2023**

(54) **FLOW PASSAGE MEMBER FOR PRESSURE SENSOR**

(71) Applicant: **Surpass Industry Co., Ltd.**, Saitama (JP)

(72) Inventors: **Hiroshi Imai**, Saitama (JP); **Masamichi Kobayashi**, Saitama (JP)

(73) Assignee: **Surpass Industry Co., Ltd.**, Saitama (JP)

(**) Term: **15 Years**

(21) Appl. No.: **29/789,405**

(22) Filed: **Sep. 21, 2021**

(30) **Foreign Application Priority Data**

Mar. 23, 2021 (JP) 2021-005985 D

(51) **LOC (14) Cl.** **10-04**

(52) **U.S. Cl.**
USPC **D10/85; D23/235**

(58) **Field of Classification Search**
USPC D10/40, 85, 96, 97, 99, 101, 102, 103; D13/162; D23/206, 233, 235, 239, 244, D23/245; D24/129
CPC . G01F 25/10; G01F 15/14; G01F 1/58; G01F 1/8409; G01F 1/00; G01F 1/3218; G01F 1/26; G01F 23/14; G01F 25/0092; A01G 25/165
See application file for complete search history.

(56) **References Cited**

U.S. PATENT DOCUMENTS

3,349,799 A * 10/1967 Mueller F16K 5/188 137/625.22
3,434,691 A * 3/1969 Hamilton F16K 5/025 251/368
D284,990 S * 8/1986 Ogilvie D23/245
D299,520 S * 1/1989 Pechler D23/245

7,404,415 B2 * 7/2008 Jacobs A01G 25/165 137/624.11
8,720,858 B2 * 5/2014 Bottcher F16K 7/126 251/331
9,746,391 B2 * 8/2017 Gagne G01N 27/10
10,215,597 B2 * 2/2019 Gagne G01F 15/14
D857,172 S * 8/2019 Shinozaki D23/245
D857,851 S * 8/2019 Shinozaki D23/245
D857,853 S * 8/2019 Shinozaki D23/245
(Continued)

OTHER PUBLICATIONS

Office Action issued in priority Design Registration Application No. 2021-005985, dated Oct. 26, 2021, entitled "Flow Passage Member for Pressure Sensor".

Primary Examiner — George D. Kirschbaum

Assistant Examiner — Lillian Windham

(74) *Attorney, Agent, or Firm* — Hamilton, Brook, Smith & Reynolds, P.C.

(57) **CLAIM**

The ornamental design for a flow passage member for pressure sensor, as shown and described.

DESCRIPTION

FIG. 1 is a front view of the flow passage member.
FIG. 2 is a rear view of the flow passage member.
FIG. 3 is a top view of the flow passage member.
FIG. 4 is a bottom view of the flow passage member.
FIG. 5 is a right side view of the flow passage member.
FIG. 6 is a left side view of the flow passage member.
FIG. 7 is a sectional view of the flow passage member as viewed along line A-A in FIG. 1.
FIG. 8 is a perspective view of the flow passage member; and,
FIG. 9 is a reference perspective view of the flow passage member and the pressure sensor.
The broken lines in the drawings depict environmental structure which forms no part of the claimed design.

1 Claim, 9 Drawing Sheets

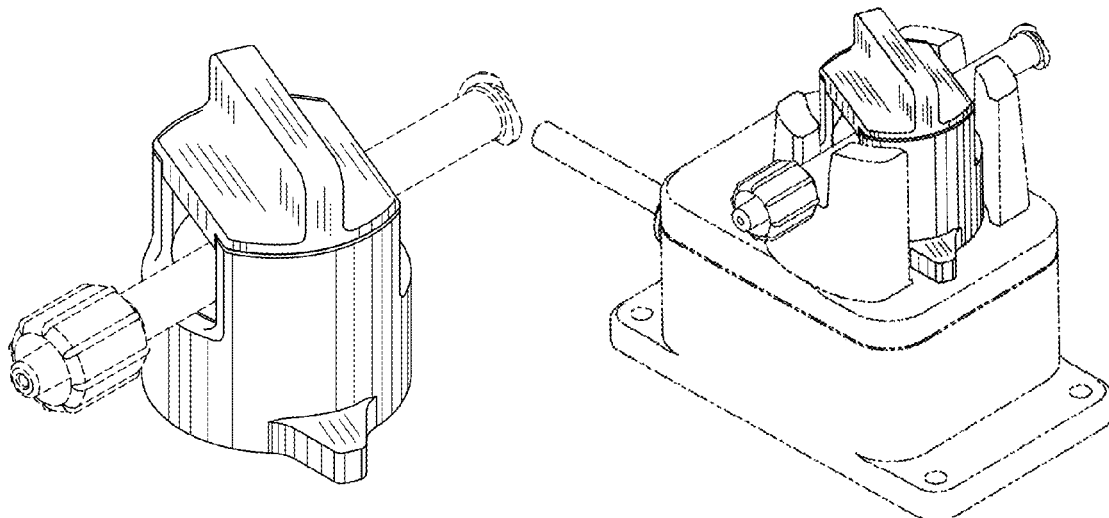

(56)

References Cited

U.S. PATENT DOCUMENTS

D924,361	S	*	7/2021	Matsushita	D23/235
D926,933	S	*	8/2021	Matsushita	D23/235
D926,934	S	*	8/2021	Matsushita	D23/235
D926,935	S	*	8/2021	Matsushita	D23/235
D927,646	S	*	8/2021	Matsushita	D23/235
D949,292	S	*	4/2022	Corre	D23/233
2009/0242818	A1	*	10/2009	Leys	F16K 27/0236 251/332

* cited by examiner

FIG. 1

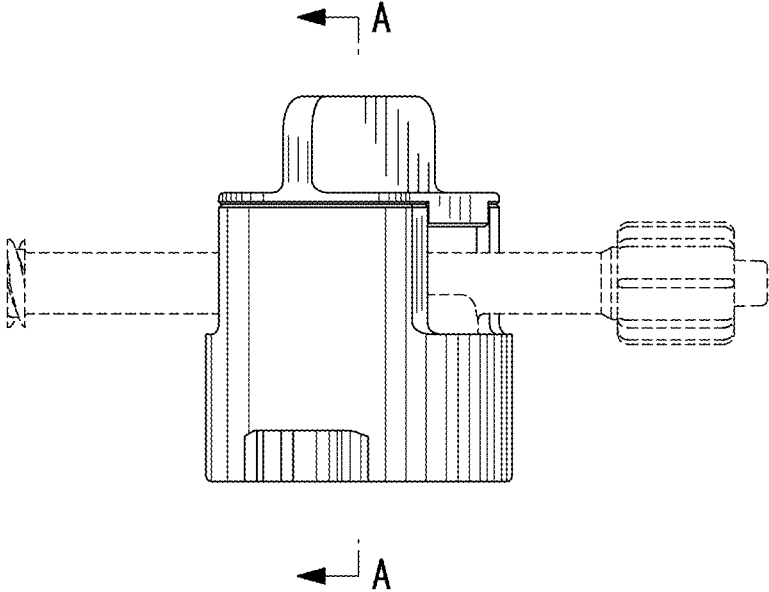

FIG. 2

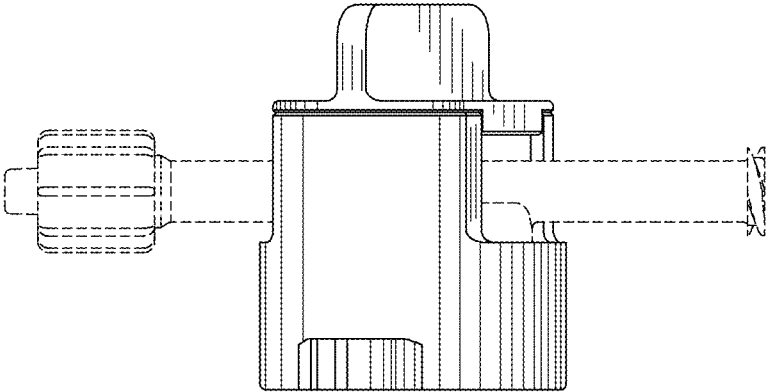

FIG. 3

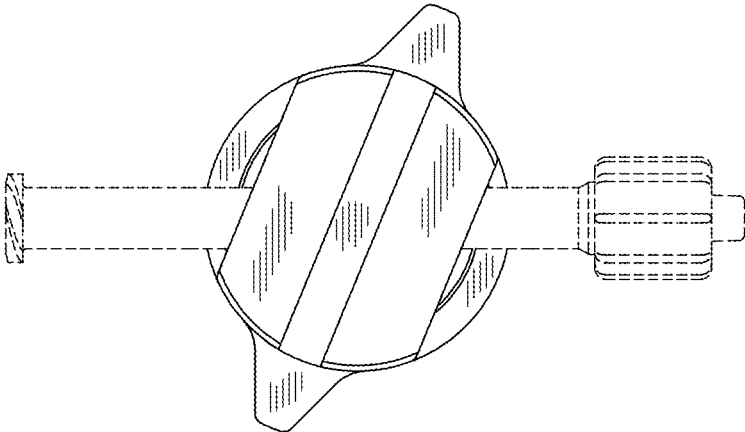

FIG. 4

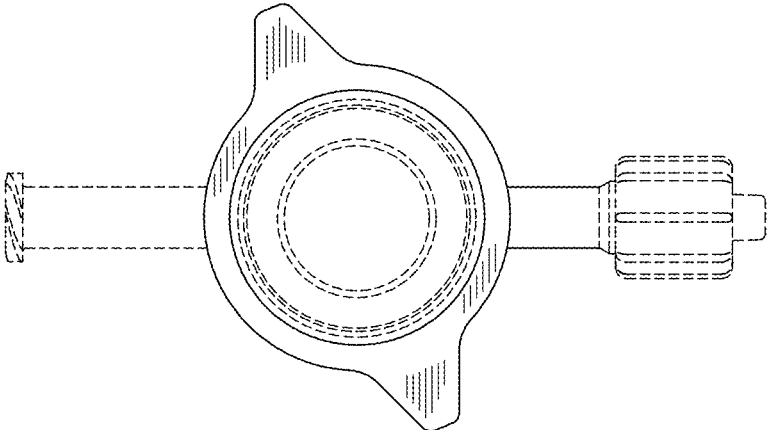

FIG. 5

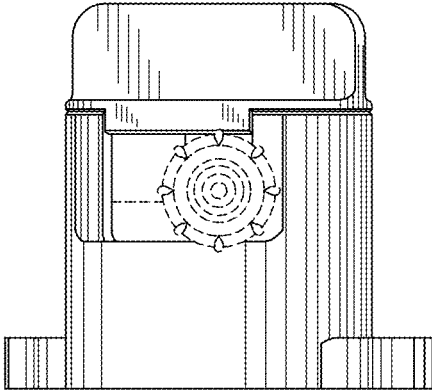

FIG. 6

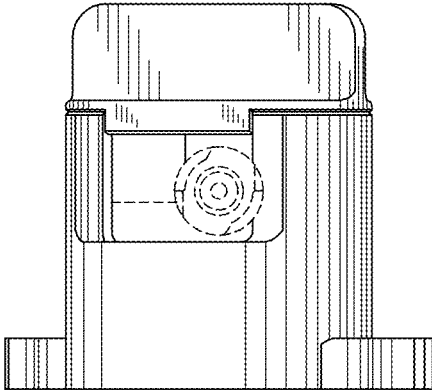

FIG. 7

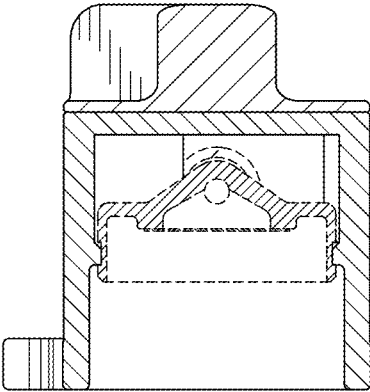

FIG. 8

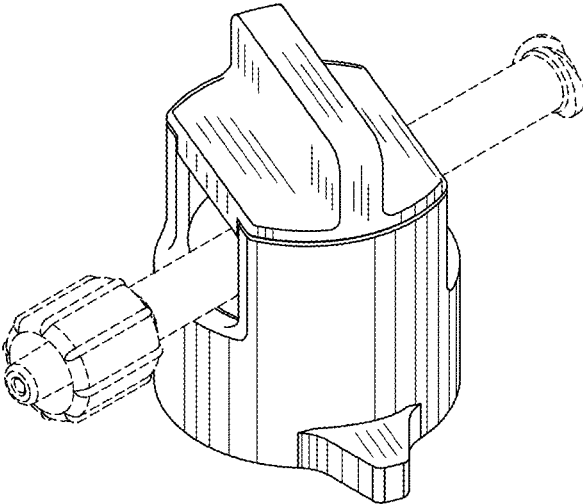

FIG. 9

