

(12) **UK Patent Application** (19) **GB** (11) **2 308 979** (13) **A**

(43) Date of A Publication **16.07.1997**

(21) Application No **9607746.6**

(22) Date of Filing **15.04.1996**

(30) Priority Data

(31) **9600352** (32) **09.01.1996** (33) **GB**

(71) Applicant(s)

Gyrus Medical Limited

(Incorporated in the United Kingdom)

**Fountain Lane, St Mellons, CARDIFF, CF3 0LX,
United Kingdom**

(72) Inventor(s)

**Nigel Mark Goble
Colin Charles Owen Goble**

(74) Agent and/or Address for Service

**Withers & Rogers
4 Dyer's Buildings, Holborn, LONDON, EC1N 2JT,
United Kingdom**

(51) INT CL⁶

A61B 17/39

(52) UK CL (Edition O)

A5R RHCE

(56) Documents Cited

**GB 2145932 A EP 0647435 A1 WO 95/24160 A1
US 5382247 A**

(58) Field of Search

**UK CL (Edition O) A5R RHCE
INT CL⁶ A61B 17/39
ONLINE DATABASE: WPI**

(54) **An electrosurgical instrument and electrode assembly**

(57) An electrosurgical instrument for treating tissue with RF energy in the presence of an electrically conductive fluid, comprises an instrument shaft 10 connectable to a handpiece and an electrode assembly 12 at the end of the shaft. The electrode assembly 12 comprises a tissue contact electrode 14 and a return electrode 18 which is spaced from and electrically insulated from the tissue contact electrode by means of an insulation member 16. The tissue contact electrode 14 is exposed at the extreme distal end 14a of the instrument and has a part-spherical surface. The distal end 14a may be axially extendable to a position spaced from the insulation member thus enlarging the electric field pattern for tissue desiccation rather than tissue vaporisation.

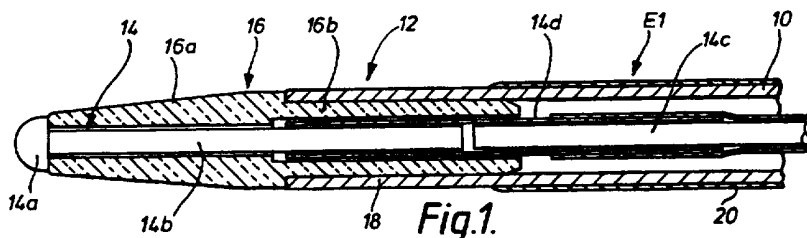

Fig.1.

GB 2 308 979 A

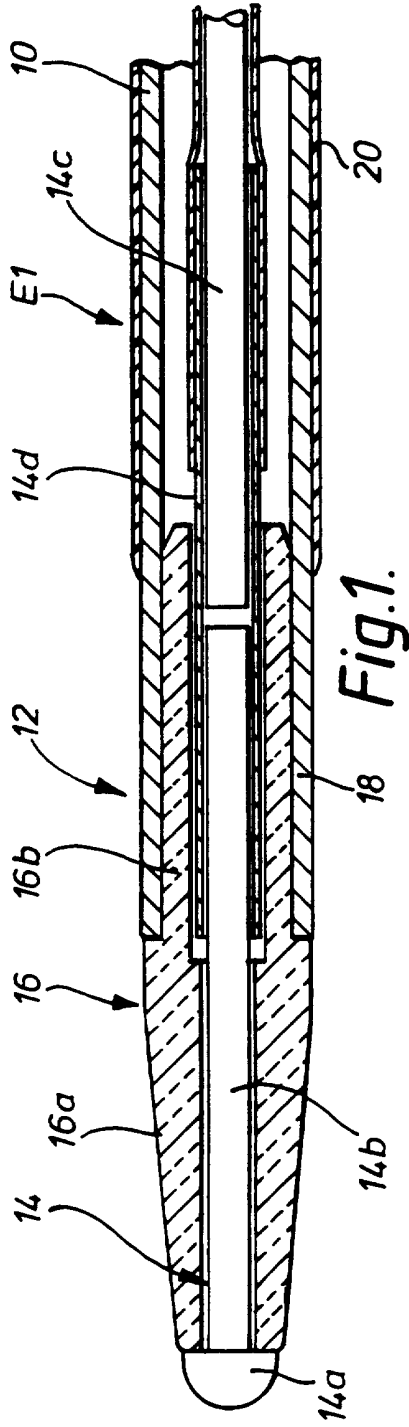

Fig. 1.

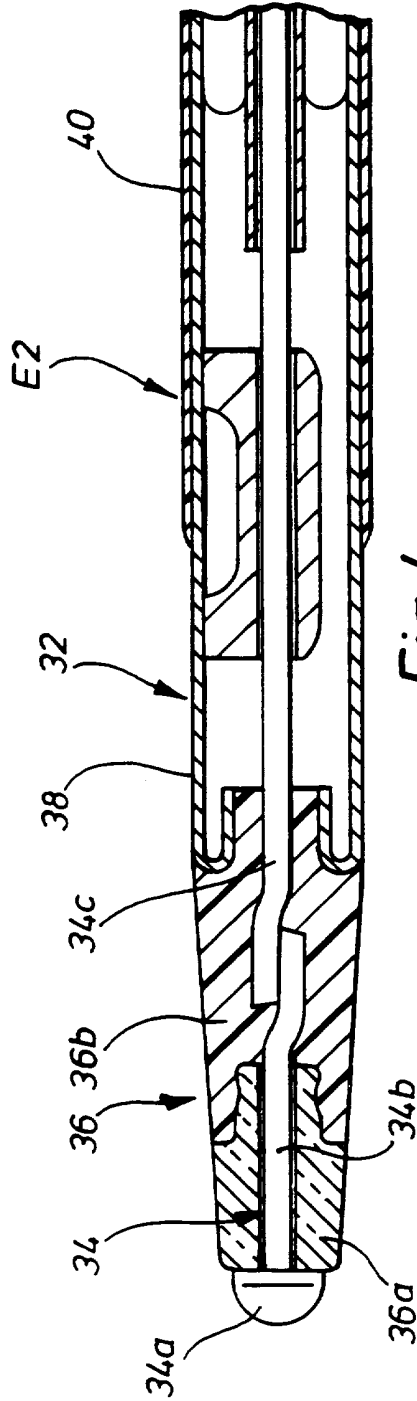

Fig. 4.

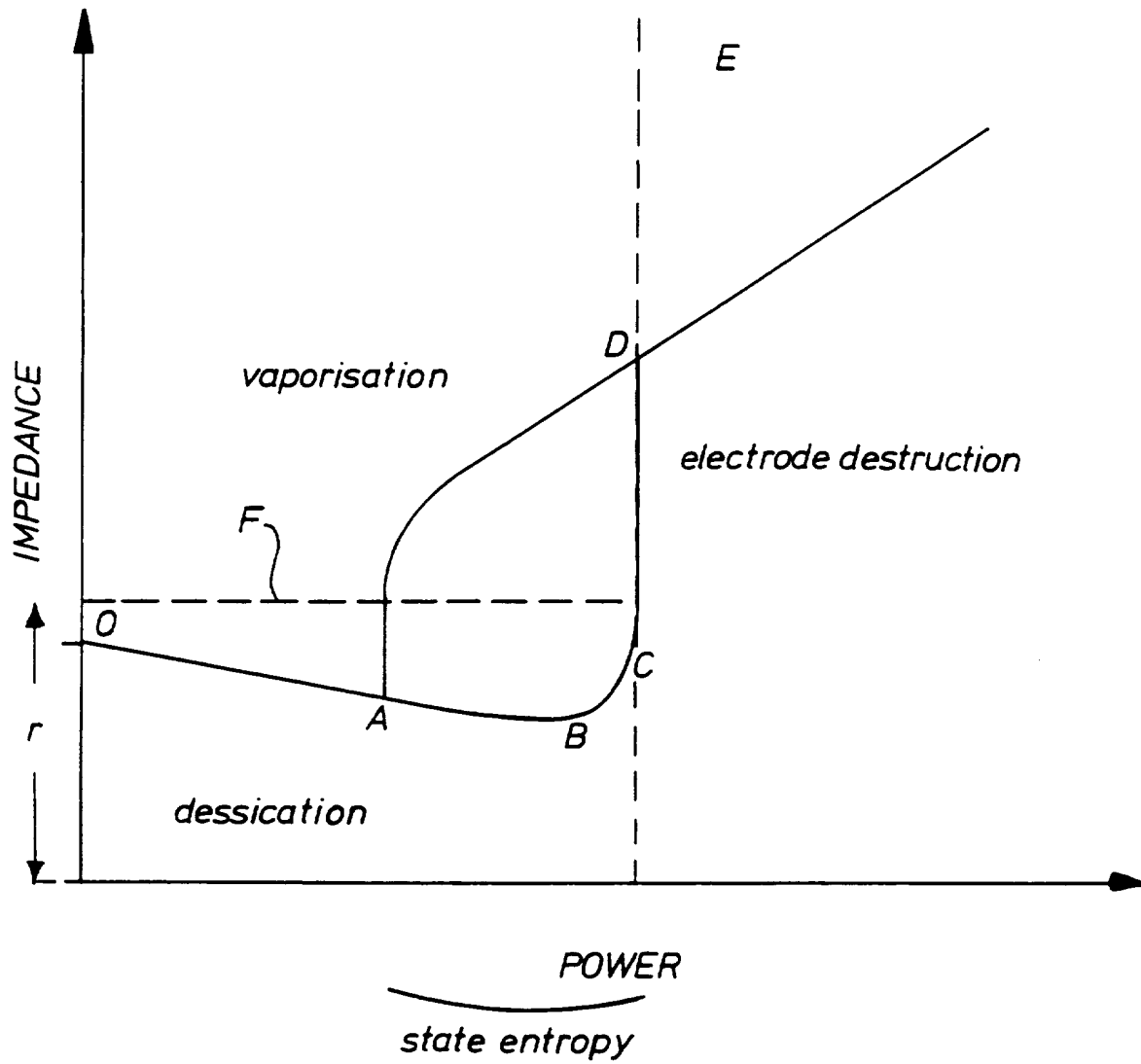

Fig.2.

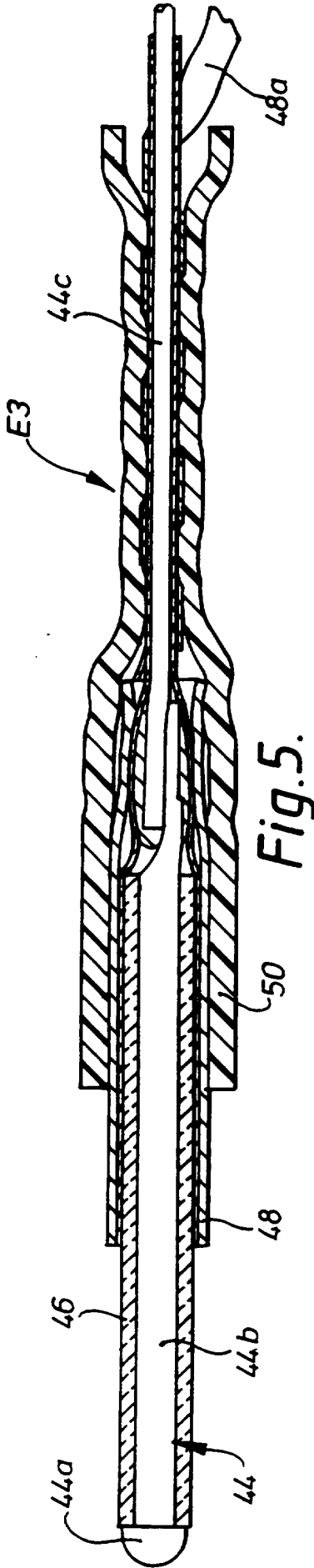

Fig. 5.

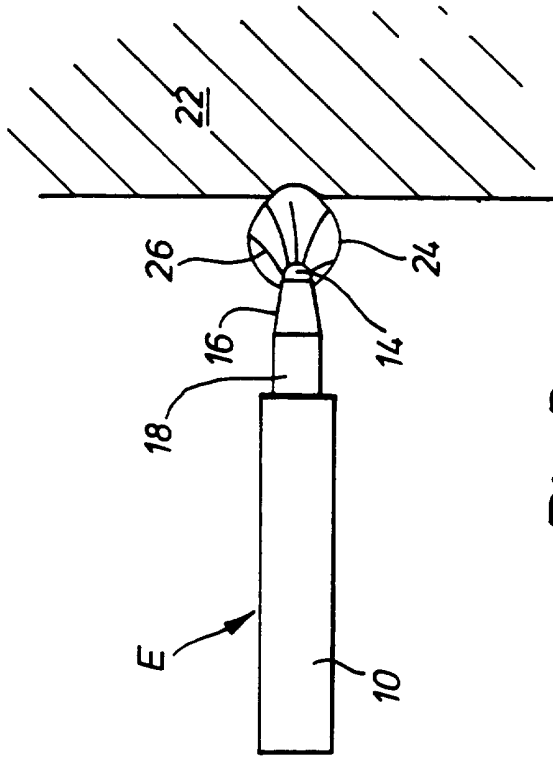
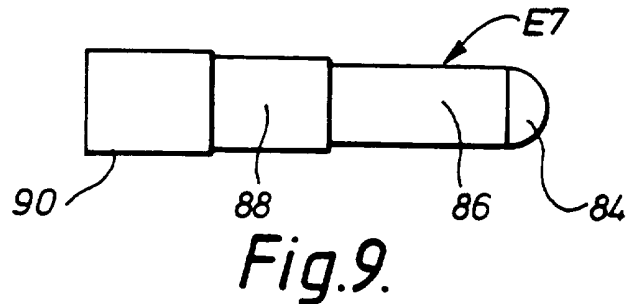
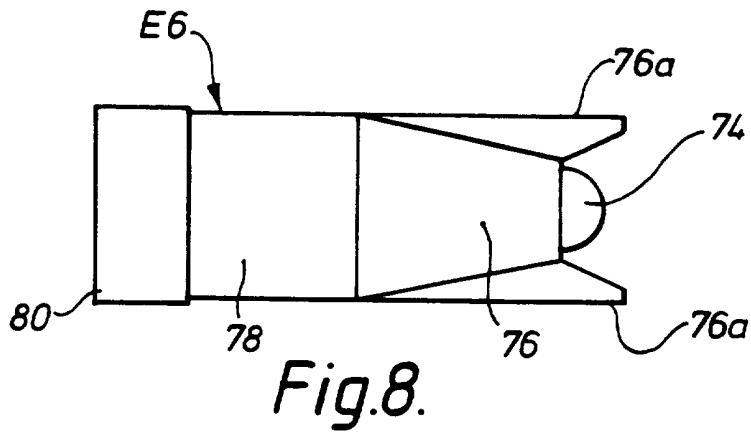
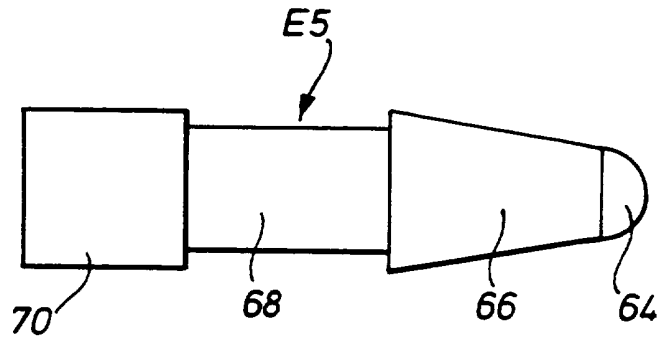
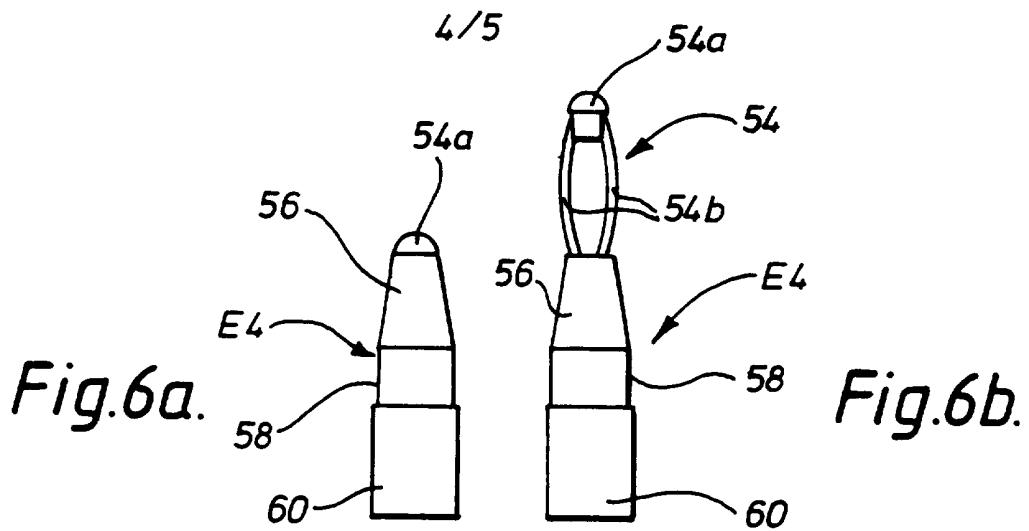

Fig. 3.



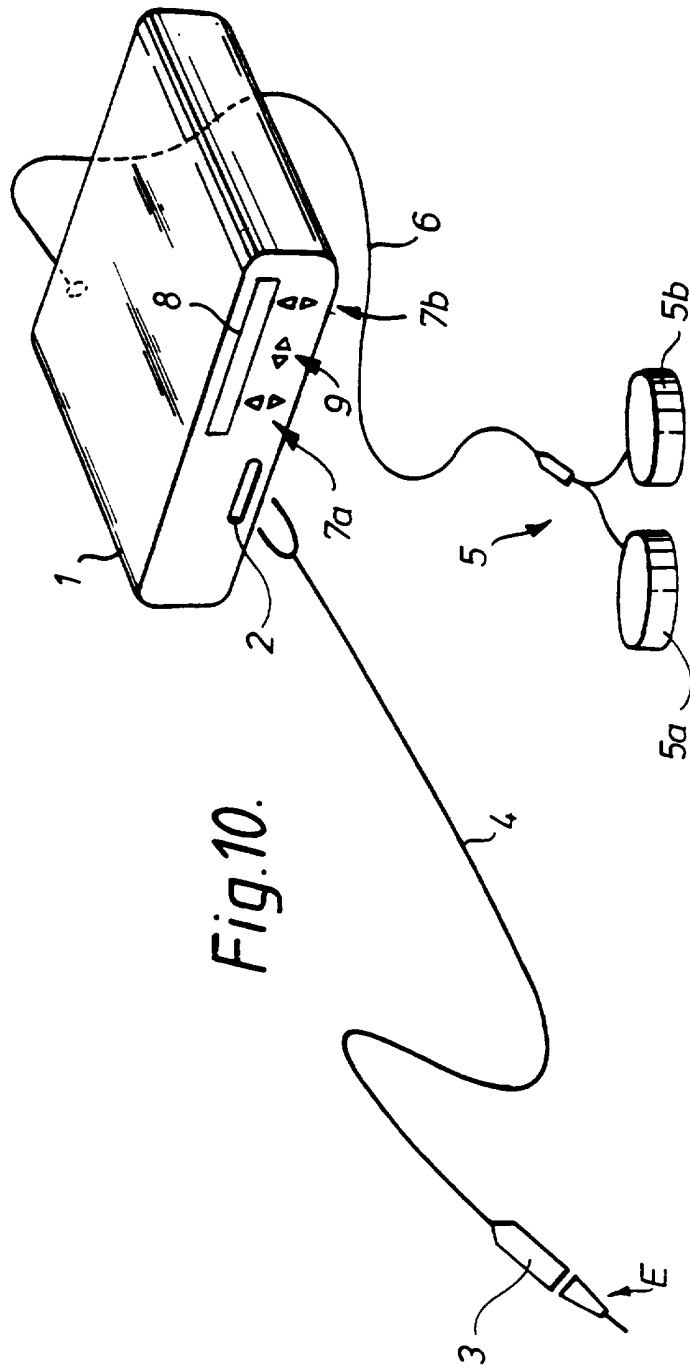

Fig.10.

AN ELECTROSURGICAL INSTRUMENT

This invention relates to an electrosurgical instrument for the treatment of tissue in the presence of an electrically conductive fluid medium, to electrosurgical apparatus including such an instrument, and to an electrode unit for use in such an instrument.

Endoscopic electrosurgery is useful for treating tissue in cavities of the body, and is normally performed in the presence of a distension medium. When the distension medium is a liquid, this is commonly referred to as underwater electrosurgery, this term denoting electrosurgery in which living tissue is treated using an electrosurgical instrument with a treatment electrode or electrodes immersed in liquid at the operation site. A gaseous medium is commonly employed when endoscopic surgery is performed in a distensible body cavity of larger potential volume in which a liquid medium would be unsuitable, as is often the case in laparoscopic or gastroenterological surgery.

Underwater surgery is commonly performed using endoscopic techniques, in which the endoscope itself may provide a conduit (commonly referred to as a working channel) for the passage of an electrode. Alternatively, the endoscope may be specifically adapted (as in a resectoscope) to include means for mounting an electrode, or the electrode may be introduced into a body cavity via a separate access means at an angle with respect to the endoscope - a technique commonly referred to as triangulation. These variations in technique can be subdivided by surgical speciality, where one or other of the techniques has particular advantages given the access route to the specific body cavity. Endoscopes with integral working channels, or those characterised as resectoscopes, are generally employed when the body cavity may be accessed through a natural body opening - such as the cervical canal to access the endometrial cavity of the uterus, or the urethra to access the prostate gland and the bladder. Endoscopes specifically designed for use in the endometrial cavity are referred to as hysteroscopes, and those designed for use in the urinary tract include cystoscopes, urethrosopes and resectoscopes. The procedures of transurethral resection or vaporisation of the prostate gland are known as TURP and EVAP respectively. When there is no natural body

opening through which an endoscope may be passed, the technique of triangulation is commonly employed. Triangulation is commonly used during underwater endoscopic surgery on joint cavities such as the knee and the shoulder. The endoscope used in these procedures is commonly referred to as an arthroscope.

5

Electrosurgery is usually carried out using either a monopolar instrument or a bipolar instrument. With monopolar electrosurgery, an active electrode is used in the operating region, and a conductive return plate is secured to the patient's skin. With this arrangement, current passes from the active electrode through the patient's tissues to
10 the external return plate. Since the patient represents a significant portion of the circuit, input power levels have to be high (typically 150 to 250 watts), to compensate for the resistive current limiting of the patient's tissues and, in the case of underwater electrosurgery, power losses due to the fluid medium which is rendered partially conductive by the presence of blood or other body fluids. Using high power with a
15 monopolar arrangement is also hazardous, due to the tissue heating that occurs at the return plate, which can cause severe skin burns. There is also the risk of capacitive coupling between the instrument and patient tissues at the entry point into the body cavity.

20 With bipolar electrosurgery, a pair of electrodes (an active electrode and a return electrode) are used together at the tissue application site. This arrangement has advantages from the safety standpoint, due to the relative proximity of the two electrodes so that radio frequency currents are limited to the region between the electrodes. However, the depth of effect is directly related to the distance between the
25 two electrodes; and, in applications requiring very small electrodes, the inter-electrode spacing becomes very small, thereby limiting tissue effect and the output power. Spacing the electrodes further apart would often obscure vision of the application site, and would require a modification in surgical technique to ensure direct contact of both electrodes with the tissue.

30

There are a number of variations to the basic design of the bipolar probe. For example, U.S. Patent Specification No. 4706667 describes one of the fundamentals of the design, namely that the ratio of the contact areas of the return electrode and of the active electrode is greater than 7:1 and smaller than 20:1 for cutting purposes. This
5 range relates only to cutting electrode configurations. When a bipolar instrument is used for desiccation or coagulation, the ratio of the contact areas of the two electrodes may be reduced to approximately 1:1 to avoid differential electrical stresses occurring at the contact between the tissue and the electrode.

10 The electrical junction between the return electrode and tissue can be supported by wetting of the tissue by a conductive solution such as normal saline. This ensures that the surgical effect is limited to the needle or active electrode, with the electric circuit between the two electrodes being completed by the tissue. One of the obvious limitations with the design is that the needle must be completely buried in the tissue
15 to enable the return electrode to complete the circuit. Another problem is one of the orientation: even a relatively small change in application angle from the ideal perpendicular contact with respect to the tissue surface, will change the contact area ratio, so that a surgical effect can occur in the tissue in contact with the return electrode.

20

Cavity distension provides space for gaining access to the operation site, to improve visualisation, and to allow for manipulation of instruments. In low volume body cavities, particularly where it is desirable to distend the cavity under higher pressure, liquid rather than gas is more commonly used due to better optical characteristics, and
25 because it washes blood away from the operative site.

Conventional underwater electrosurgery has been performed using a non-conductive liquid (such as 1.5% glycine) as an irrigant, or as a distension medium to eliminate electrical conduction losses. Glycine is used in isotonic concentrations to prevent
30 osmotic changes in the blood when intra-vascular absorption occurs. In the course of an operation, veins may be severed, with resultant infusion of the liquid into the

circulation, which could cause, among other things, a dilution of serum sodium which can lead to a condition known as water intoxication.

The applicants have found that it is possible to use a conductive liquid medium, such as normal saline, in underwater endoscopic electrosurgery in place of non-conductive, electrolyte-free solutions. Normal saline is the preferred distension medium in underwater endoscopic surgery when electrosurgery is not contemplated, or a non-electrical tissue effect such as laser treatment is being used. Although normal saline (0.9%w/v; 150mmol/l) has an electrical conductivity somewhat greater than that of most body tissue, it has the advantage that displacement by absorption or extravasation from the operative site produces little physiological effect, and the so-called water intoxication effects of non-conductive, electrolyte-free solutions are avoided.

Carbon dioxide is the preferred gaseous distension medium, primarily because of its non-toxic nature and high water solubility.

In endoscopic procedures in which the distension medium is a gas, the applicants have found that it is possible to use an electrically-conductive gas (such as argon) in place of carbon dioxide. Argon is conductive when excited into a discharge state, and has been employed in both endoscopic and conventional monopolar electrosurgery as a method of increasing the distance between the tissue and the instrument, by providing a conductive path between the two when high voltage electrosurgical outputs such as spray or fulgurate are being used. The high voltages used in this application result in a very low penetration of the electrosurgical effect into the tissue, making the technique only suitable to control bleeding from multiple small blood vessels. This allows the surgeon to stanch bleeding from multiple sites in a surgical wound using a rapid "painting" technique, rather than applying electrosurgery to each individual bleeding site. The argon gas is delivered through a hollow surgical instrument, and passes over the monopolar electrode exposed at the tip of the instrument as a stream. This produces a region at the operative site which is rich in argon, and which contributes to the distension of the body cavity. High voltage monopolar electrosurgical outputs

are undesirable in endoscopic surgery, because of the risks of damaging structures outside the field of vision, by either capacitive or direct coupling to a portion of the instrument remote from the operative site often outside the field of vision of the operator.

5

The applicants have developed a bipolar instrument suitable for underwater electrosurgery using a conductive liquid or gaseous medium. This electrosurgical instrument for the treatment of tissue in the presence of a fluid medium, comprises an instrument body having a handpiece and an instrument shaft and an electrode assembly,
10 at one end of the shaft. The electrode assembly comprises a tissue contact electrode which is exposed at the extreme distal end of the instrument, and a return electrode which is electrically insulated from the tissue contact electrode and has a fluid contact surface spaced proximally from the exposed part of the tissue contact electrode. In use of the instrument, the tissue contact electrode is applied to the tissue to be treated
15 whilst the return electrode, being spaced proximally from the exposed part of the tissue contact electrode, is normally spaced from the tissue and serves to complete an electrosurgical current loop from the tissue contact electrode through the tissue and the fluid medium. This electrosurgical instrument is described in the specification of the applicants' co-pending British Patent Application No. 9512889.8.

20

The electrode structure of this instrument, in combination with an electrically-conductive fluid medium largely avoids the problems experienced with monopolar or bipolar electrosurgery. In particular, input power levels are much lower than those generally necessary with a monopolar arrangement (typically 100 watts). Moreover,
25 because of the relatively large spacing between its electrodes, an improved depth of effect is obtained compared with conventional bipolar arrangements.

The aim of the invention is to provide an improved electrosurgical instrument of this type.

30

The present invention provides an electrosurgical instrument for the treatment of tissue in the presence of an electrically-conductive fluid medium, the instrument comprising
5 an instrument shaft, and an electrode assembly at one end of the shaft, the electrode assembly comprising a tissue contact electrode and a return electrode which is electrically insulated from the tissue contact electrode by means of an insulation member, the tissue contact electrode being exposed at the extreme distal end of the instrument, and the return electrode having a fluid contact surface spaced proximally
10 from the exposed end of the tissue contact electrode by the insulation member, wherein the exposed end of the tissue contact electrode is a part-spherical surface.

In a preferred embodiment, the fluid contact surface of the tissue contact electrode is generally hemispherical.

15

Advantageously, the tissue contact electrode is constituted by an active tip defining the fluid contact surface of the electrode and a central conductor, the insulation member surrounding the central conductor. Preferably, the active tip is made of a precious metal such as platinum or an alloy such as platinum/iridium, platinum/tungsten or
20 platinum/cobalt, or from tungsten.

Conveniently, the insulation member tapers towards the distal end of the instrument and is made of ceramic material, silicone rubber or glass.

25 In a preferred embodiment, the tissue contact electrode has an active tip, the active tip having the part-spherical exposed end surface, and wherein the tissue contact electrode is mounted within the insulation member in such a manner that the active tip is axially movable relative to the insulation member between a first operating position, in which the active tip lies against the distal end face of the insulation member, and a second
30 operating position, in which the active tip is axially spaced from the distal end face of the insulation member.

In another preferred embodiment, the insulation member is formed with at least one wing, the or each wing extending distally from the insulation member to project beyond the tissue contact electrode. Preferably, the insulation member is formed with a pair of diametrically-opposed wings. The wing(s) can be used to trap a laminate structure to be treated against the tissue contact electrode, and to prevent unnecessary exposure of the tissue contact electrode which could otherwise damage adjacent structures when working in the confined spaces commonly encountered in endoscopic surgery.

10 The invention also provides an electrode unit for an electrosurgical instrument for the treatment of tissue in the presence of an electrically-conductive fluid medium, the electrode unit comprising a shaft having at one end means for connection to an instrument handpiece, and, mounted on the other end of the shaft, an electrode assembly comprising a tissue contact electrode and a return electrode which is
15 electrically insulated from the tissue contact electrode by means of an insulation member, the tissue contact electrode being exposed at the extreme distal end of the instrument to provide a fluid contact surface, and the return electrode having a fluid contact surface spaced proximally from the fluid contact surface of the tissue contact electrode by the insulation member, wherein the fluid contact surface of the tissue
20 contact electrode is a part-spherical surface.

The invention also provides electrosurgical apparatus comprising a radio frequency generator and an electrosurgical instrument for the treatment of tissue in the presence of an electrically-conductive fluid medium, the instrument comprising an instrument
25 shaft, and an electrode assembly at one end of the shaft, the electrode assembly comprising a tissue contact electrode and a return electrode which is electrically insulated from the tissue contact electrode by means of an insulation member, the tissue contact electrode being exposed at the extreme distal end of the instrument, the return electrode having a fluid contact surface spaced proximally from the exposed end
30 of the tissue contact electrode by the insulation member, and the radio frequency generator having a bipolar output connected to the electrodes, wherein the exposed end of the tissue contact electrode is a part-spherical surface.

Advantageously, the radio frequency generator includes control means for varying the output power delivered to the electrodes, and the control means is such as to provide output power in first and second output ranges, the first output range being for powering the electrosurgical instrument for tissue desiccation, and the second output range being for powering the electrosurgical instrument for tissue removal by cutting or vaporisation. Preferably, the first output range is from about 150 volts to 200 volts, and the second output range is from about 250 volts to 600 volts, the voltage being peak voltages.

10 The invention will now be described in greater detail, by way of example with reference to the drawings, in which:-

Figure 1 is a diagrammatic side elevation of an electrode assembly at a distal end of a first form of electrode unit constructed in accordance with the invention;

15

Figure 2 is a graph illustrating the hysteresis which exists between the use of the electrode unit of Figure 1 in desiccating and vaporising modes;

Figure 3 is a diagrammatic side elevation of the first electrode unit, showing the use of such a unit for tissue removal by vaporisation;

20

Figure 4 is a longitudinal section through the electrode assembly of a second form of electrode unit constructed in accordance with the invention;

25 Figure 5 is a longitudinal section through the electrode assembly of a third form of electrode unit constructed in accordance with the invention;

Figures 6a and 6b are diagrammatic side elevations of the electrode assembly of a fourth form of electrode unit constructed in accordance with the inventions;

30

Figures 7 to 9 are diagrammatic side elevations of fifth to seventh forms of electrode units constructed in accordance with the invention; and

Figure 10 is a diagram showing an electrosurgical apparatus constructed in accordance with the invention.

Each of the electrode units described below is intended to be used with a conductive distension medium such as normal saline or argon, and each unit has a dual-electrode structure, with the conductive medium acting as a conductor between the tissue being treated and one of the electrodes, hereinafter called the return electrode. The other electrode is applied directly to the tissue, and is hereinafter called the tissue contact (active) electrode. In many cases, the use of a liquid distension medium is preferable, as it prevents excessive electrode temperatures in most circumstances, and largely eliminates tissue sticking.

Referring to the drawings, Figure 10 shows electrosurgical apparatus including a generator 1 having an output socket 2 providing a radio frequency (RF) output for an instrument in the form of a handpiece 3 via a connection cord 4. Activation of the generator 1 may be performed from the handpiece 3 via a control connection in the cord 4, or by means of a footswitch unit 5, as shown, connected separately to the rear of the generator 1 by a footswitch connection cord 6. In the illustrated embodiment, the footswitch unit 5 has two footswitches 5a and 5b for selecting a desiccation mode and a vaporisation mode of the generator 1 respectively. The generator front panel has push buttons 7a and 7b for respectively setting desiccation and vaporisation power levels, which are indicated in a display 8. Push buttons 9a are provided as an alternative means for selection between the desiccation and vaporisation modes.

The handpiece 3 mounts a detachable electrode unit E, such as the electrode units E1 to E7 to be described below.

Figure 1 shows the first form of electrode unit E1 for detachable fastening to the electrosurgical instrument handpiece 3, the electrode unit comprising a shaft 10, which is constituted by a semi-flexible tube made of stainless steel or phynox electroplated in copper or gold, with an electrode assembly 12 at a distal end thereof. At the other

end (not shown) of the shaft 10, means are provided for connecting the electrode unit E1 to the handpiece 3 both mechanically and electrically.

A radio frequency (RF) generator (not shown) is provided for delivering an electro-
5 surgical current to the electrode assembly 12. The generator includes means for varying the delivered output power to suit different electrosurgical requirements. The generator may be as described in the specification of our co-pending British Patent Application 9512888.0.

10 The electrode assembly 12 includes a central, tissue contact (active) electrode 14 which is made of platinum, platinum/iridium or platinum/tungsten, and is constituted by a generally hemispherical active tip 14a and an integral central conductor 14b. The conductor 14b is electrically connected to a central copper conductor 14c by crimping
15 a thin-walled stainless steel tube 14d over the adjacent end portions of the conductors 14b and 14c, thereby providing an electrical connection between the handpiece 3 of the instrument and the active tip 14a. A ceramic insulation sleeve 16 surrounds the conductor 14b, the tube 14d and the adjacent end portion of the copper conductor 14c. The sleeve 16 is formed with a tapering portion 16a which surrounds the distal end portion of the conductor 14b, and with an inwardly-stepped cylindrical portion 16b.
20 A return electrode 18, which is constituted by the distal end portion of the shaft 10, closely surrounds the sleeve portion 16b and extends over the copper conductor 14c in spaced relation thereto. An outer insulating polyimide coating 20 surrounds the proximal portion of the return electrode 18.

25 By varying the output of the generator, the electrode unit E1 of Figure 1 can be used for tissue removal by vaporisation, for sculpturing and contouring menisci during arthroscopic surgery, or for desiccation. Figure 2 illustrates how the RF generator can be controlled to take advantage of the hysteresis which exists between the desiccation and the vaporising modes of the electrode unit E1. Thus, assuming the electrode
30 assembly 12 of the unit E1 is immersed in a conductive medium such as saline, there is an initial impedance "r" at point "O", the magnitude of which is defined by the geometry of the electrode assembly and the electrical conductivity of the fluid medium.

The value of "r" will change when the active electrode 14 contacts tissue, the higher the value of "r" the greater the propensity of the electrode assembly 12 to enter the vaporisation mode. When RF power is applied to the electrode assembly 12 the fluid medium heats up. Assuming the fluid medium is normal saline (0.9% w/v), the temperature coefficient of conductivity of the fluid medium is positive, so that the corresponding impedance coefficient is negative. Thus, as power is applied, the impedance initially falls and continues to fall with increasing power to point "B", at which point the saline in intimate contact with the electrode assembly 12 reaches boiling point. Small vapour bubbles form on the surface of the active tip 14a and the impedance then starts to rise. After point "B", as power is increased further, the positive power coefficient of impedance is dominant, so that increasing power now brings about increasing impedance.

As a vapour pocket forms from the vapour bubbles, there is an increase in the power density at the residual electrode/saline interface. There is, however, an exposed area of the active tip 14a not covered by vapour bubbles, and this further stresses the interface, producing more vapour bubbles and thus even higher power density. This is a run-away condition, with an equilibrium point only occurring once the electrode is completely enveloped in vapour. For given set of variables, there is a power threshold before this new equilibrium can be reached (point "C").

The region of the graph between the points "B" and "C", therefore, represents the upper limit of the desiccation mode. Once in the vaporisation equilibrium state, the impedance rapidly increases to around 1000 ohms, with the absolute value depending on the system variables. The vapour pocket is then sustained by discharges across the vapour pocket between the active tip 14a and the vapour/saline interface. The majority of power dissipation occurs within this pocket, with consequent heating of the active tip 14a. The amount of energy dissipation, and the size of the pocket, depends on the output voltage. If this is too low, the pocket will not be sustained, and if it is too high the electrode assembly 12 will be destroyed. Thus, in order to prevent destruction of the electrode assembly 12, the power output of the generator must be reduced once the impedance has reached the point "D". It should be noted that, if the power is not

reduced at this point, the power/impedance curve will continue to climb and electrode destruction would occur. The dotted line E indicates the power level above which electrode destruction is inevitable. As the power is reduced, the impedance falls until, at point "A", the vapour pocket collapses and the electrode assembly 12 reverts to the desiccation mode. At this point, power dissipation within the vapour pocket is insufficient to sustain it, so that direct contact between the active tip 14a and the saline is re-established, and the impedance falls dramatically. The power density at the active tip 14a also falls, so that the temperature of the saline falls below boiling point. The electrode assembly 12 is then in a stable desiccation mode. With the generator described in the specification of our co-pending British patent application 9604770.9, the output is 250 to 600 volts peak for the vaporisation mode, and 150 volts to 200 volts peak for the desiccation mode.

It will be apparent that the electrode unit E1 of Figure 1 can be used for desiccation by operating the unit in the region of the graph between the point "0" and a point in the region between the points "B" and "C". In this case, the electrode assembly 12 would be introduced into a selected operation site with the active tip 14a adjacent to the tissue to be treated, and with the tissue and the active tip and the return electrode immersed in the saline. The RF generator would then be activated (and cyclically controlled as described in the specification of our co-pending British patent application 9604770.9) to supply sufficient power to the electrode assembly 12 to maintain the saline adjacent to the active tip 14a at, or just below, its boiling point without creating a vapour pocket surrounding the active tip. The electrode assembly would then be manipulated to cause heating and desiccation of the tissue in a required region adjacent to the active tip 14a. The electrode unit E1 can be used for vaporisation in the region of the graph between the point "D" and the dotted line F which constitutes the level below which vaporisation cannot occur. The upper part of this curve is used for tissue removal by vaporisation. In this mode, a light application of the instrument to the tissue to be treated enables sculpturing and contouring to be carried out.

30

The electrode assembly 12 has a return: active electrode ratio in the range of from 5:1 to 40:1 (that is to say the ratio of the areas of the two electrodes are in this range).

The temperature generated at the active tip 14a is of the order of 1500°C in the vaporisation mode, which requires the use of platinum or platinum alloys (such as platinum/iridium or platinum/tungsten) for fabrication of this member. It is also important that the diameter of the tip 14a does not exceed the diameter of the distal end of the tapering portion 16a of the ceramic isolation sleeve 16. Otherwise, a direct conduction path would be created which would intensify the power density around that part of the active tip 14a which protrudes radially beyond the isolation sleeve 16.

Figure 3 illustrates the use of the electrode unit E1 of Figure 1 for tissue removal by vaporisation. Thus, the electrode unit E1 creates a sufficiently high energy density at the active tip 14a to vaporise tissue 22, and to create a vapour pocket 24 surrounding the active tip. The formation of the vapour pocket 24 creates about a 10-fold increase in contact impedance, with a consequent increase in output voltage. Arcs 26 are created in the vapour pocket 24 to complete the circuit to the return electrode 18. Tissue 22 which contacts the vapour pocket 24 will represent a path of least electrical resistance to complete the circuit. The closer the tissue 22 comes to the active tip 14a, the more energy is concentrated to the tissue, to the extent that the cells explode as they are struck by the arcs 26, because the return path through the connective fluid (saline in this case) is blocked by the high impedance barrier of the vapour pocket 24. The saline solution also acts to dissolve or disperse the solid products of vaporisation.

In use, the electrode assembly 12 would be introduced into a selected operation site with the active tip 14a adjacent to the tissue to be vaporised, and with the tissue, the active tip and the return electrode 18 immersed in the saline. The RF generator would then be activated to supply sufficient power (as described above with reference to Fig. 2) to the electrode assembly 12 to vaporise the saline and to maintain a vapour pocket surrounding the tissue contact electrode. When the electrode unit E1 is used for sculpturing or contouring menisci during arthroscopic surgery, the electrode assembly is applied with light pressure at the selected operation site, and is manipulated so that the part-spherical surface of the active tip 14a moves across the surface to be treated, smoothing away tissue, and in particular menisci, with a sculpturing or contouring action.

The electrode unit E1 of Figure 1 could be modified by dispensing with the stainless tube 14d and butt welding the two conductors 14b and 14c together. The active tip 14a could also be made of a precious metal such as platinum, a platinum alloy such as platinum/tungsten, platinum/iridium or platinum/cobalt, or tungsten, and the return electrode 18 could be made of a stainless steel ferrule crimped over a copper conductor strip. In this case, the outer coating 20 could be a thermoplastic flexible twin lumen tube. Alternatively, the return electrode 18 could be constituted by a metallised coating on the proximal end portion of the insulation sleeve 16. In this case, a flexible thermoplastics tube constituting the sleeve 20 could be formed with a metallised coating on its inner wall, this metallised coating being in electrical contact with the metallised coating constituting the return electrode.

Figure 4 shows the electrode assembly 32 of the second form of electrode unit E2. The electrode assembly 32 includes a central, tissue contact (active) electrode 34 which is made of a precious metal such as platinum, a platinum alloy such as platinum/tungsten, platinum/iridium or platinum/cobalt, or tungsten, and is constituted by a generally hemispherical active tip 34a and a central conductor 34b. The conductor 34b is soldered or spot welded to a central copper conductor 34c. A composite insulation sleeve 36 surrounds the conductor 34b and the adjacent end portion of the copper conductor 34c.

The sleeve 36 is constituted by a thermal barrier portion 36a made of bead, glass or ceramic material, and an injection moulded thermoplastics encapsulation portion 36b. A return electrode 38, constituted by a semi-flexible thin walled tube made of stainless steel or phynox electro-plated in copper or gold, closely surrounds the proximal end of the sleeve portion 36b. This tube also constitutes the shaft of the electrode unit E2. The tube constituting the return electrode 38 is formed with an in-turned U-shaped distal end portion 28a which is encapsulated within the sleeve portion 36b. An outer insulating polyimide or PTFE heat shrink coating 40 surrounds the proximal portion of the return electrode 38.

The electrode unit E2, like the unit E1, can be used for desiccation, for tissue removal by vaporisation, and for sculpturing and contouring tissue such as menisci during arthroscopic surgery. The unit E2 operates in a similar manner to the electrode unit E1 of Figure 1. Here again, the electrode unit E2 could be modified in a number of
5 ways. For example, an epoxy or silicone rubber potting could replace the injection moulded thermoplastic encapsulation portion 36b, and the return electrode 38 could be constituted by a copper plated glass fibre composite semi-flexible tube which surrounds the central copper conductor 34c at the proximal end thereof. Alternatively, the sleeve portion 36b could be made of an injection moulded polymer, the central conductor 34b
10 could be made of stainless steel, and the active tip 34a could be made of an electro-plated precious metal.

Figure 5 shows the electrode assembly 42 of the third form of electrode unit E3. The electrode assembly 42 includes a central, tissue contact (active) electrode 44, which is
15 made of a precious metal such as platinum, a platinum alloy such as platinum/tungsten, platinum/iridium or platinum/cobalt or tungsten, and is constituted by a generally hemispherical active tip 44a, and a central conductor 44b. The conductor 44b is spot welded or soldered to a central copper conductor 44c. A ceramic insulation tube 46 surrounds the conductor 44b, the ceramic tube terminating at the proximal end thereof
20 in the region adjacent to the joint between the two conductors 44b and 44c. A return electrode 48, constituted by a stainless steel tube, closely surrounds the proximal end of the ceramic tube 46. This tube also constitutes the shaft to the electrode unit E3. The return electrode 48 is connected to a copper foil return conductor 48a by crimping. An outer insulating PTFE heat shrink sleeve 50 surrounds the proximal portion of the
25 return electrode 48.

Here again, the electrode unit E3 can be used for desiccation, for tissue removal by vaporisation, and for sculpturing and contouring. It operates in a similar manner to the electrode units E1 and E2.

30

Figures 6a and 6b show a fourth form of electrode unit E4 whose electrode assembly 52 which includes an extensible active electrode 54. The electrode unit E4 also

includes a ceramic insulation sleeve 56, a return electrode 58 and an insulating sheath 60. As shown in Figure 6a, the active electrode 54 can be withdrawn within the insulation sleeve 56, so that its active tip 54a only is exposed. With the active electrode 54 in this position, the electrode unit E4 can be used to vaporise tissue or for
5 smoothing. On the other hand, if the active electrode 54 is extended (see Figure 6b), so that its support structure 54b extends from the distal end of the sleeve 56, the electrode unit E4 can be used for desiccation. The ratio of the contact areas of the return to active electrodes of the unit E4 can, therefore, be varied between the fully retracted active electrode position (in which the ratio is high and the unit is used for
10 cutting or vaporisation), and the extended position (in which the ratio is low and the unit is used for desiccation). Of course, the electrode unit E4 could be used for desiccation with the active electrode 54 retracted, though this would not be as effective as desiccation with the active electrode extended. The active tip 54a is made of a precious metal such as platinum, a platinum alloy such as platinum/tungsten, platinum
15 iridium or platinum/cobalt, or tungsten.

The electrode unit E4 achieves its dual functionality by varying the axial separation between the active electrode 54 and the return electrode 58. With a large axial electrode separation, a larger electric field is created, so that more tissue is affected.
20 With a reduced electrode separation, a smaller electric field is produced, and is used for vaporisation or sculpturing and contouring in circumstances where no collateral thermal damage to tissue is desirable. The larger electric field pattern is desirable for desiccation, or in circumstances where the desiccation of collateral tissue is desirable to prevent haemorrhage from a cut surface.

25

The electric field pattern may also be adjusted by recessing the return electrode of a probe-type electrode unit. Thus, Figure 7 shows an electrode unit E5 having an active electrode (only the generally hemispherical active tip 64 of which is visible), a tapered insulation sleeve 66, a recessed return electrode 68, and an outer insulating sleeve 70.
30 Here again, the electrode unit E5 can be used for desiccation, for tissue removal by vaporisation, and for smoothing. Because the return electrode 68 is recessed, it interferes with electric field pattern, making the pattern larger. This increased field

pattern results in greater tissue interaction, and hence a better desiccation action when the electrode unit E5 is used in the desiccation mode.

Figure 8 shows the electrode assembly 72 of the sixth form of electrode unit E6. The
5 electrode assembly 72 includes a central, tissue contact (active) electrode (only the
generally hemispherical active tip 74 of which is visible), a tapered ceramic insulation
sleeve 76, a return electrode 78, and an outer insulating sleeve 80. The insulation
sleeve 76 is formed with a pair of diametrically-opposed, forwardly extending wings
76a which project beyond the active tip 74. The electrode unit E6 is particularly useful
10 for electrosurgical operations on meniscal cartilage or any other elongate laminate
structure which is to be treated from the side, as the wings 76a can be used to trap the
cartilage against the active electrode 74. The configuration of the wings 76a also
assists in preventing unnecessary exposure of the active electrode 74 which may
otherwise damage adjacent structures when working in the confined spaces commonly
15 encountered in endoscopic surgery.

The method of operation of a conventional bipolar needle probe requires the active
electrode to be buried in tissue. This requirement strictly limits the configuration of
the active electrode to be of needle or wire form, so as to be compatible with tissue
20 penetration without electrosurgical support. The electrosurgical instrument of the
present invention, on the other hand, does not suffer from such a design constraint.

Moreover, a conventional bipolar electrosurgical instrument requires the return
electrode to contact tissue before the electrical circuit is completed. This requires the
25 return electrode to be positioned alongside the active electrode, and so obscures
visualisation of the active electrode during tissue application. This is very
disadvantageous to the surgeon who, under such circumstances, will be at risk of
unwittingly dividing an important structure. The electrode units of the invention do
not suffer from this disadvantage, as the return electrode is axially spaced from the
30 active electrode. The tapering of the insulation sleeve also helps to provide the
surgeon with direct visualisation of the active electrode during tissue application.

Another important factor which restricts the use of conventional bipolar instruments, is that, for maximum effect, the active electrode must be orientated very close to the perpendicular with respect to the tissue surface. If this angle is progressively reduced, there comes a point where the diameter of the return electrode will prevent the active electrode contacting tissue. Even before this point is reached, the ratio of return to active electrode contact area will be elevated to a point where the effect of the active electrode will be reduced. The bipolar electrosurgical instruments described above do not suffer from these disadvantages as the electrode ratio is maintained by the conductive fluid medium, and the axial separation between the electrodes enables the instrument to be angled without the return electrode contacting tissue.

Where an electrode unit having a very small diameter (1 to 2 millimetres) is required, a fabrication technique that is different from that used for the larger diameter electrode units can be used. Thus, in an electrode unit of such a small size, there is no requirement to taper the insulation sleeve between the two electrodes in order to improve visualisation of the tip. Figure 9 illustrates a seventh form of electrode unit E7 which is constructed using a method based on "tube within tube" fabrication. Thus, the electrode unit E7 has an electrode assembly 82 having an active electrode (only the generally hemispherical active tip 84 of which is visible), an insulation sleeve 86 which surrounds a central conductor (not shown) attached to the active tip, a return electrode 88 surrounding the sleeve 86, and an outer insulating sleeve 90 surrounding the insulating sleeve. The electrode unit E7 could be modified to provide a recessed return electrode 88 by providing an insulating collar at the distal end of the return electrode.

The active tips 64, 74 and 84 of the embodiments of Figs 7 to 9 are made of a precious metal such as platinum, a platinum alloy such as platinum/tungsten, platinum/iridium or platinum/cobalt, or tungsten.

The active electrode tips 14a, 34a, 44a, 54a, 64, 74 and 84 are all "ball" electrodes. This type of electrode is a specific form of a solid construction active electrode having a rounded tissue contact surface. The return:active electrode area ratio of those ball electrodes is typically large, being in the range of from 5:1 to 40:1, and preferably in

the range of from 20:1 to 30:1. Electrodes with this large ratio typically require less power to reach the vaporisation threshold. Moreover, due in part to the low thermal mass of such an active electrode, ball electrodes create less thermal effect at the margins of tissue removal. They are, therefore, primarily intended to produce
5 controlled vaporisation or contact debulking of tissue. They produce a more precise effect compared to known high power monopolar electrosurgical vaporising electrodes, such as those used in EVAP. Similarly, the high ratio limits the desiccating capability to a precise spot effect, and reduces the effect progressively from a maximum when perpendicular to the tissue surface to a minimum when nearly parallel to the tissue
10 surface. Primarily, therefore, ball electrodes are end-effect electrodes.

The rounded tip of such a ball electrode allows for a surface smoothing effect and the elimination of any devitalised tissue remaining at the site of application. Where a ball electrode is used on dense tissue, such as meniscal cartilage, where there is a
15 propensity for the electrode to slip during application, the winged design of Figure 8 can be used to assist with tissue engagement.

As end-effect electrode, this type of ball electrode has tissue debulking precision with minimal thermal spread. Consequently, it can be used to create discrete holes in tissue,
20 thereby to create an access channel to tissue deep to the surface, as may be required as part of an interstitial ablation technique on a tissue mass such as a prostate adenoma or a uterine fibroid (myolysis). This use of a vaporising, end-effect, technique enables only the fibroid to be removed by complete debulking leaving a resection margin conforming to the "false capsule" of the fibroid. No normal tissue is removed and, due
25 to control of collateral thermal effects at the endometrial resection margin, the scarring is reduced to a minimum, thereby increasing what chances there were of restoring fertility. Additionally, of course, vaporisation does not produce resection chippings to interfere with visualisation and prolong the procedure through the need to wash them out once the resection is completed. Conventional loop electrode resectoscopes require
30 removal of normal tissue surrounding such fibroids, and this is disadvantageous because it increases the chance of bleeding, the risk of uterine perforation and the

scarring of the uterus. This latter aspect is particularly undesirable when the procedure is being performed in an attempt to restore fertility.

Alternatively, a ball electrode hysteroscope can be used to trim of the resection margins following use of a more aggressive vaporising electrode, or by using the multiple
5 puncture or drilling technique. In this case, after removing the intrauterine portion, the intramural portion can be treated by creating ("drilling") a series of holes into the abnormal tissue whether, for example, this is a fibroid or prostatic adenoma. To assess the depth of penetration, marks may be provided on the electrode shaft at measured
10 distances from the tip, and hence to compare the depth of penetration against the pre-operative results of tests performed to establish size of the tumour or adenoma. The residual tissue bridges will shrink as part of the healing process. Whilst not removing the whole tumour, this technique is safer and quicker than removing the entire fibroid or prostatic adenoma, when treatment is being performed either for menorrhagia or
15 bladder outflow obstruction, respectively.

Being of a solid form, these ball electrodes are robust, and this is an important feature when such an electrode is introduced through an endoscope with a narrow or tortuous working channel, particularly a flexible endoscope with an angled instrument channel.

20

An arthroscope electrode may be characterised as short (100-140mm), rigid with a working diameter up to 4mm. It can be introduced through a stab incision into a joint cavity (with or without a cannula) using the triangulation technique. When an arthroscope includes a ball electrode of the type described above, it is operated with
25 a motion which commonly moves the ball electrode between the 9 o'clock and 3 o'clock positions on the arthroscopic image. As a result, the tissue to be treated is commonly approached at a shallow working angle with respect to the axis of the electrode. The electrode for arthoscopy thus needs to have an effect consistent with this angled approach to the tissue. The tissue to be treated, such as meniscal cartilage,
30 is commonly dense and of a high electrical impedance, such tissue having a free edge representing a common injury site where treatment is required. It is difficult to engage this free edge with the rounded tip of a simple ball electrode, so the winged

arrangement of Figure 8 is used for such applications, the wings assisting with tissue engagement, and preventing unwanted effects occurring in adjacent structures; usually the articular surfaces of the femur and tibia.

- 5 One application of this type of ball electrode in arthroscopy, where a precise application point of desiccation is desirable, is in simulating the laser-assisted capsular shift procedure (LACS). This technique involves the application of energy to the inner aspect of joint capsules to provide a thermally-induced shrinkage of the collagen fibres which support the joint. These fibres often become stretched through repetitive strain
- 10 injuries, particularly amongst certain sports people, which renders the joint susceptible to partial or complete dislocation. Tightening of the collagen fibres to restore the integrity of the joint, using the LACS technique, provides an attractive option to open surgical alternatives.
- 15 A hysteroscope electrode may be characterised as long (350-400mm), flexible or semi-rigid with a working diameter typically in the range of 1.27-2.86mm (4-9Fr). Such an instrument is introduced through a working channel; and is, therefore, always viewed along the axis of the electrode at the 6 o'clock and 12 o'clock positions on the hysteroscopic image. This type of electrode assembly is commonly manipulated in a
- 20 stroking action against tissue within the field of view of the hysteroscope. Alternatively, the active electrode is held fixed with respect to the hysteroscope, and the hysteroscope is manipulated using a combined side-to-side and withdrawal action, a so-called "painting" technique. The tissue is commonly more vascular than that encountered during arthroscopic surgery, and inadvertent perforation of the uterus
- 25 represents a serious complication. It is desirable, therefore, to support a more controlled application using electrodes with good desiccation capability using more precise movements of the electrode or hysteroscope than is normal during arthroscopic procedures. The extensible active ball electrode embodiment of Figure 6 has sufficient desiccation power to decrease the return:active area ratio, and so permit good
- 30 desiccation using the painting technique.

In endoscopic urological procedures, there are two main areas of application for this type of ball electrode, namely vaporisation of bladder tumour recurrences using a flexible cystoscope, and debulking of the prostate gland, as part of an interstitial procedure, whilst sparing the prostatic urethra. The former application requires
5 performance characteristics very similar to that of the hysteroscope as it must be introduced through the working channel which is often tortuous and angled. In this case, tumour recurrences are often small and treatment is associated with little risk of haemorrhage. Because of the robustness of the ball electrode, such recurrences can easily be treated with this electrode configuration, despite the more exacting
10 requirements of a flexible working channel or the use of electrode directors (mechanical devices which are provided on the instrument for changing the angle of the working channel at the tip such as the Alberron type instrument).

To produce an access channel to the substance of a prostatic adenoma, the electrode
15 shaft must be directed at a 90° angle with respect to the shaft of the urethrocystoscope whilst it is in position in the prostatic urethra. This may be done as a prelude to interstitial ablation (thermally-induced necrosis) or interstitial vaporisation, both techniques producing a progressive shrinkage or immediate debulking of the prostate adenoma deep to the urethral surface. This reduces operative time and the level of
20 anaesthesia, such that the procedure may be performed on a day case basis. Alternatively, a series of holes can be created with the islands of preserved urethra between the application sites regrowing over these sites as the adenoma shrinks.

It will be apparent that modifications could be made to the electrosurgical instruments
25 described above. For example, the insulation sleeves 16, 36, 46, 56, 66, 76 and 86 could be made of a silicone rubber (such as silicone polyurethane), a polyimide, glass or a thermoplastics material. Also the outer insulating coatings 20, 40, 50, 60, 70, 80 and 90 would be made of polyvinylidene fluoride, polytetrafluoroethylene, a polyolefin, a polyester or ethylene tetrafluorethylene. The electrode unit E6 could also be
30 modified by varying the member of wings 76a, it being possible to have a single wing or three or more wings.

CLAIMS

1. An electrosurgical instrument for the treatment of tissue in the presence of an electrically-conductive fluid medium, the instrument comprising an instrument shaft, and an electrode assembly at one end of the shaft, the electrode assembly comprising a tissue contact electrode and a return electrode which is electrically insulated from the tissue contact electrode by means of an insulation member, the tissue contact electrode being exposed at the extreme distal end of the instrument, and the return electrode having a fluid contact surface spaced proximally from the exposed end of the tissue contact electrode by the insulation member, wherein the exposed end of the tissue contact electrode is a part-spherical surface.

2. An electrosurgical instrument as claimed in claim 1, wherein the fluid contact surface of the tissue contact electrode is generally hemispherical.

3. An electrosurgical instrument as claimed in claim 1, wherein the tissue contact electrode is constituted by an active tip defining the fluid contact surface of the electrode and a central conductor, the insulation member surrounding the central conductor.

4. An electrosurgical instrument as claimed in claim 3, wherein the active tip is made of a precious metal such as platinum.

5. An electrosurgical instrument as claimed in claim 3, wherein the active tip is made of a platinum alloy such as platinum/iridium, platinum/tungsten or platinum/cobalt.

6. An electrosurgical instrument as claimed in claim 1, wherein the insulation member tapers towards the distal end of the instrument.

7. An electrosurgical instrument as claimed in claim 1, wherein the insulation member is made of a ceramic material.

8. An electrosurgical instrument as claimed in claim 1, wherein the insulation member is made of silicone rubber.
- 5 9. An electrosurgical instrument as claimed in claim 1, wherein the tissue contact electrode has an active tip, the active tip having the part-spherical exposed end surface, and wherein the tissue contact electrode is mounted within the insulation member in such a manner that the active tip is axially movable relative to the insulation member between a first operating position, in which the active tip lies against the distal end
10 face of the insulation member, and a second operating position, in which the active tip is axially spaced from the distal end face of the insulation member.
10. An electrosurgical instrument as claimed in claim 1, wherein the insulation member is formed with at least one wing, the or each wing extending distally from the
15 insulation member to project beyond the tissue contact electrode.
11. An electrosurgical instrument as claimed in claim 10, wherein the insulation member is formed with a pair of diametrically-opposed wings.
- 20 12. An electrode unit for an electrosurgical instrument for the treatment of tissue in the presence of an electrically-conductive fluid medium, the electrode unit comprising a shaft having at one end means for connection to an instrument handpiece, and, mounted on the other end of the shaft, an electrode assembly comprising a tissue contact electrode and a return electrode which is electrically insulated from the tissue
25 contact electrode by means of an insulation member, the tissue contact electrode being exposed at the extreme distal end of the instrument, and the return electrode having a fluid contact surface spaced proximally from the exposed end of the tissue contact electrode by the insulation member, wherein the exposed end of the tissue contact electrode is a part-spherical surface.
- 30 13. Electrosurgical apparatus comprising a radio frequency generator and an electrosurgical instrument for the treatment of tissue in the presence of an electrically-

conductive fluid medium, the instrument comprising an instrument shaft, and an electrode assembly at one end of the shaft, the electrode assembly comprising a tissue contact electrode and a return electrode which is electrically insulated from the tissue contact electrode by means of an insulation member, the tissue contact electrode being
5 exposed at the extreme distal end of the instrument, the return electrode having a fluid contact surface spaced proximally from the exposed end of the tissue contact electrode by the insulation member, and the radio frequency generator having a bipolar output connected to the electrodes, wherein the exposed end of the tissue contact electrode is a part-spherical surface.

10

14. Apparatus as claimed in claim 13, wherein the radio frequency generator includes control means for varying the output power delivered to the electrodes.

15. Apparatus as claimed in claim 14, wherein the control means is such as to
15 provide output power in first and second output ranges, the first output range being for powering the electrosurgical instrument for tissue desiccation, and the second output range being for powering the electrosurgical instrument for tissue removal by cutting or vaporisation.

20 16. Apparatus as claimed in claim 15, wherein the first output range is from about 150 volts to 200 volts, and the second output range is from about 250 volts to 600 volts, the voltage being peak voltages.



Application No: GB 9607746.6
Claims searched: All

Examiner: Gareth Griffiths
Date of search: 22 May 1996

Patents Act 1977
Search Report under Section 17

Databases searched:

UK Patent Office collections, including GB, EP, WO & US patent specifications, in:
UK CI (Ed.O): A5R (RHCE)
Int CI (Ed.6): A61B 17/39
Other: Online Database: WPI

Documents considered to be relevant:

Category	Identity of document and relevant passage	Relevant to claims
X, Y	GB2145932 A (MATBURN) whole document	X: 1-3, 12 Y: 7, 8
X, Y	EP0647435 A1 (ARROW) whole document	X: 1-5, 12-14 Y: 7, 8
X, Y	WO95/24160 A1 (CARDIMA) page 9 lines 5-16 & fig 3	X: 1-3, 12-14 Y: 7, 8
Y	US5382247 (CIMINO) col 4 lines 55-56	7, 8

X	Document indicating lack of novelty or inventive step	A	Document indicating technological background and/or state of the art.
Y	Document indicating lack of inventive step if combined with one or more other documents of same category.	P	Document published on or after the declared priority date but before the filing date of this invention.
&	Member of the same patent family	E	Patent document published on or after, but with priority date earlier than, the filing date of this application.